



# CRMR48-D4

## Commercial Series Undercounter Refrigerator with Drawers

CRMR48-D4  
8/14  
Item #13333

Hoshizaki America, Inc. reserves the right to change specifications without notice.



Item #

Project:

Qty:

\*AutoCad available on KCL

### CRMR-D4 Dimensions W x D x H

2 Section - 48" x 30" x 33.63\*\*

\*\*with 4" casters

### Electrical/Refrigeration

**Voltage** 115/60/1

**HACR Breaker**  
2 Section - 15.0

**Electrical Connection (NEMA)**  
2 Section - 5-15P

**Voltage Range** 104-126

**Ambient Temp. Range** 45°-100°F

**Temperature Range** 32° to 52°F

\*Refrigerant R-134a

### Warranty

Valid in United States, Canada, Puerto Rico, and U.S. Territories. Contact factory for warranty in other countries.

- **Three Year** - Parts & Labor on entire machine.
- **Five Year** - Parts on: Compressor.

### Options

- 2.25" Casters - to meet ADA
- 6" Casters
- 6" Legs
- Stainless steel back



- Stainless steel exterior front, sides and top
- Anodized Aluminum interior sides and back with stainless steel interior floor
- Front breathing air flow design
- Stainless steel exterior drawer with ABS interior liner
- Cabinet and drawers are insulated with 2" foamed in place polyurethane
- Drawer slides are constructed of 16 gauge stainless steel with acetal rollers
- Drawers will accommodate (1) 1/2 and (1) 1/3 size pans, 6" deep (pans by others)
- Extruded aluminum flush mount drawer handle
- Magnetic drawer gasket is easily removable for cleaning
- Enamel coated evaporator coil
- Standard with 4" stem casters (two with brakes)
- Three years parts and labor warranty
- Five year compressor warranty
- 8 ft. cord and plug

### Dimensions / Capacity

| Model #                               | Two Section<br>CRMR48-D4               |
|---------------------------------------|--|
| Nominal Storage Capacity (CF)         | 13.66 ft <sup>3</sup>                  |
| Interior Storage Capacity (CF) (AHAM) | 11.95 ft <sup>3</sup>                  |
| Overall Width x Depth                 | 48" x 30"                              |
| Height (including 4" casters)         | 33.63"                                 |
| Drawer Opening Width x Height         | 19.5" x 22.9"                          |
| Depth with Drawer Fully Open          | 49.25"                                 |
| Pan Capacity                          | (1) 1/2 size and (1) 1/3 size, 6" deep |
| Crated Shipping Weight                | 262 lbs                                |
| Crated Height x Width x Depth         | 36.5" x 52.5" x 34"                    |

### Electrical / Refrigeration Data

| Model #                             | Two Section<br>CRMR48 |
|-------------------------------------|-----------------------|
| Amperage                            | 2.6                   |
| Energy Consumption (kwh/day) @NSF   | 2.3                   |
| Heat Rejection (BTU/Hr.) @NSF       | 327                   |
| Approx. Nominal Compres. BTU/HR(HP) | 1029(1/6HP)           |



© HOSHIZAKI AMERICA, INC.

618 Hwy. 74 S., Peachtree City, GA 30269  
TEL 800-438-6087  
FAX 800-345-1325  
www.hoshizaki.com



# CRMR48-D4

Commercial Series Undercounter Refrigerator with Drawers

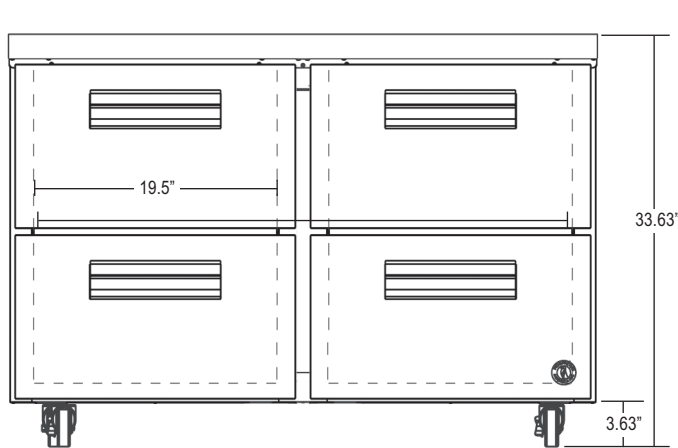

CRMR48-D4  
FRONT

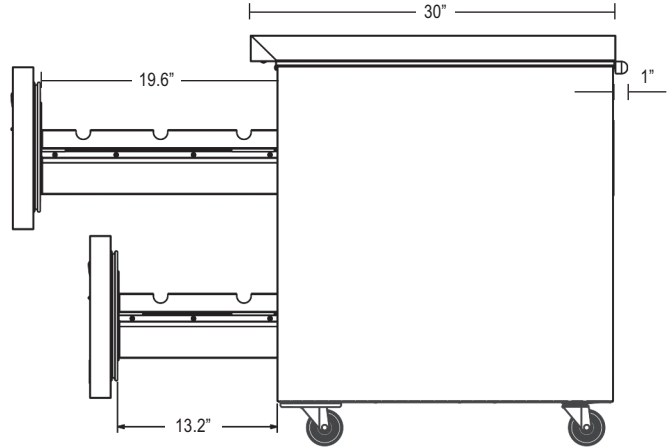

RIGHT SIDE VIEW

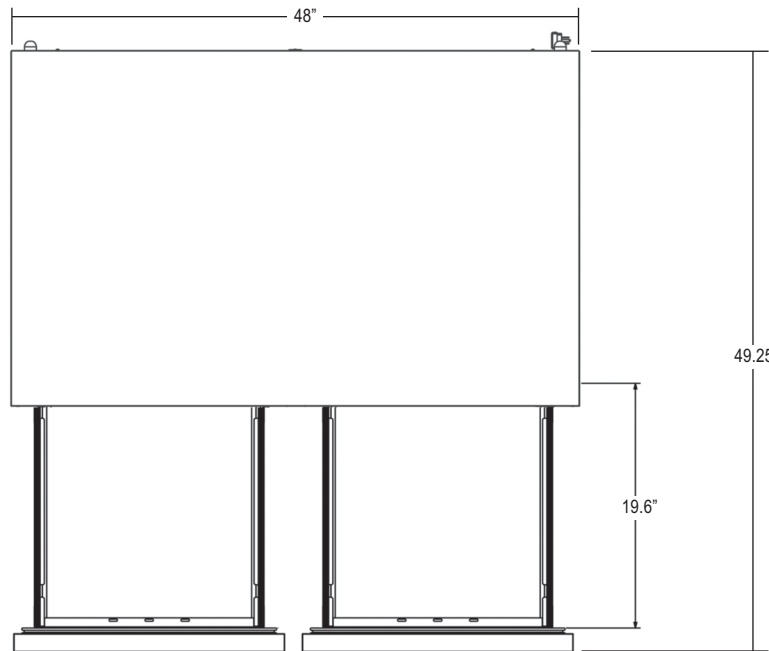

CRMR48-D4  
PLAN VIEW

### Cabinet Construction

The exterior cabinet top, front, and sides, are constructed of high quality stainless steel. The exterior back and bottom are constructed of coated steel. The cabinet interior back and sides are anodized aluminum with an ABS ceiling and stainless steel floor. One heavy duty epoxy coated shelf per section is standard. Mounted on anodized aluminum pilasters the shelves are adjustable in 1/2" increments. Cabinet walls and doors are insulated with 2" of environmentally friendly, CFC free, foamed in place polyurethane. 4" polyolefin, stem casters (two with brakes) are standard.

### Drawer Construction

Drawer fronts are constructed of high grade stainless steel inside with ABS interior liners and are insulated with R-134a CFC free foamed in place polyurethane. Each drawer accommodates (1) 1/2 size and (1) 1/3 size pan per drawer, 6" deep (pans by others). Drawer frames are formed of 14 gauge stainless steel and securely fastened in the cabinet. The drawer slides are 16 gauge stainless steel with acetal rollers to prevent metal to metal contact between the drawer slides and reduce wear. The drawer slides have a dynamic load capacity of 175 lbs. and have been life tested (fully loaded) three hundred thousand openings and closings without showing significant wear. The flush mount handles are constructed of extruded aluminum. Snap-in magnetic drawer gaskets are durable and easily removed for cleaning.

### Refrigeration System

The high efficiency refrigeration system is self-contained with an enamel coated evaporator for extended life. Condensate removal is accomplished with an energy efficient non-electric evaporation system. A capillary tube controls the flow of environmentally friendly R-134A refrigerant through the evaporator. Refrigeration system utilizes an "off cycle" defrost to eliminate any ice on the evaporator coil. 115 volt units are equipped with an eight foot cord and plug (20.0 amps or less).

© HOSHIZAKI AMERICA, INC.

618 Hwy. 74 S., Peachtree City, GA 30269 • TEL 800-438-6087 • FAX 800-345-1325 • www.hoshizaki.com



Intertek



Intertek



ISO 9001:2015