

Technical data sheet for

E22M3 DOUBLE STACKED

Half Size Manual / Electric Convection Ovens

Double Stacked on a Stainless Steel Base Stand



Model E22M3/2C shown



E22M3/2 E22M3/2C

E22M3 ovens shall be Moffat electrically heated Turbofan convection ovens E.T.L. listed and NSF-4 listed. The ovens shall have a one piece porcelain enameled oven chamber, stainless top and sides and safe touch vented easy clean drop down door. Ovens shall have capacity for three half size sheet pans. The ovens shall have a single direction low velocity fan system. The ovens shall be controlled by a mechanical thermostat with a range of 150-500°F / 50-260°C, and 60 minute bake timer. Ovens shall be fitted with a NEMA 5-15P cordset. Ovens shall be double stacked using Double Stacking Kits DSK2223 (adjustable feet option) or DSK2223C (castor option). Units shall be supplied in 100% recyclable shipping packaging.

Double stack models are supplied as two individual ovens and a double stacking kit for field assembly.

E22M3/2 - Double stack with adjustable feet base stand

E22M3/2C - Double stack with castor base stand

DOUBLE STACK FEATURES

- Two 3 half size ovens
- Compact 24"/ 610mm width
- Full stainless steel base stand
- Full stainless steel oven spacer frame
- Adjustable feet or castor models
- Guard rail for bottom oven

OVEN FEATURES (each)

- 3 half size sheet pan capacity
- 2 $\frac{5}{8}$ " / 70mm tray spacing
- Single direction low-velocity fan
- 1.5kW heating power
- 110-120V plug-in 15A NEMA 5-15P cordset fitted
- Porcelain enameled oven chamber
- Plug-in continuous oven door seal
- Safe-Touch vented drop down door
- Stay-Cool door handle
- Heavy-duty door hinges
- Easy clean door glass system
- Mechanical thermostat 150-500°F / 50-260°C
- 60 minute timer with time up alarm
- 3 oven wire racks supplied

E22M3/2 E22M3/2C Half Size Manual / Electric Convection Ovens Double Stacked on a Stainless Steel Base Stand

CONSTRUCTION - OVENS

Porcelain enameled fully welded oven chamber
Stainless steel front, sides and top exterior
Stainless steel oven fan baffle
Removable 3 position chrome plated wire side racks
Oven racks chrome plated wire (3 supplied)
Stainless steel frame drop down hinged door
0.2" / 5mm thick door outer glass
0.2" / 5mm thick low energy loss door inner glass
Heavy-duty counterbalanced door hinges
Wear resistant powder coated welded door handle
Stainless steel control panel
Aluminized coated steel base and rear panels

CONSTRUCTION - DOUBLE STACKING KIT

All stainless steel construction
Welded 1½" and 1¼" square tube front and rear frame
base stand
4 adjustable feet on E22M3/2
4 dia. 3" / 76mm swivel castors with 2 front castors dual
wheel and swivel lock on E22M3/2C
Stainless steel oven spacer frame
Aluminized steel bottom oven vent extension

CONTROLS (each oven)

Power ON control panel indicator
Mechanical thermostat 150-500°F / 50-260°C
Heating ON control panel indicator
Manual 60 minute timer
Time-Up control panel indicator and buzzer

CLEANING

Stainless steel top and sides continuous exterior panel
Porcelain enameled oven chamber
Fully removable chrome plated oven side racks
Removable stainless steel oven fan baffle
Easy clean door system with hinge out door inner glass
(no tools required)
Removable plug-in oven door seal (no tools required)

SPECIFICATIONS

Electrical Requirements (each oven)
110-120V, 50/60Hz, 1-phase, 1.5kW, 12A
NEMA 5-15P cordset fitted



External Dimensions

Width 24" / 610mm
Height 57½" / 1461mm (E22M3/2)
60¾" / 1543mm (E22M3/2C)
Depth 25¾" / 645mm

Oven Internal Dimensions (each oven)

Width 19½" / 495mm
Height 10" / 250mm
Depth 13¾" / 340mm
Volume 1.48ft³ / 0.042m³

Oven Rack Dimensions

Width 18" / 460mm
Depth 13" / 330mm

Nett Weight (double stack complete)

192lbs / 87kg

Packing Data (E22M3 ovens each)

106lbs / 48kg
12ft³ / 0.34m³
Width 29½" / 750mm
Height 27¾" / 705mm
Depth 25" / 635mm

Packing Data (Stacking Kit)

33lbs / 15kg (DSK2223 - adjustable feet)
40lbs / 18kg (DSK2223C - castor)
2.8ft³ / 0.08m³
Width 23¼" / 590mm
Height 33⅞" / 840mm
Depth 6¼" / 160mm

Supplied CKD for assembly on site

INSTALLATION CLEARANCES

Rear 1" / 25mm
LH Side 1" / 25mm
RH Side 1" / 25mm

CLEARANCE FROM SOURCES OF HEAT

A minimum distance of 12" / 300mm from the appliance
sides is required

Double Stacking Kits

For after market double stacking two E22M3 convection ovens
DSK2223 - Double stacking kit - adjustable feet
DSK2223C - Double stacking kit - castor

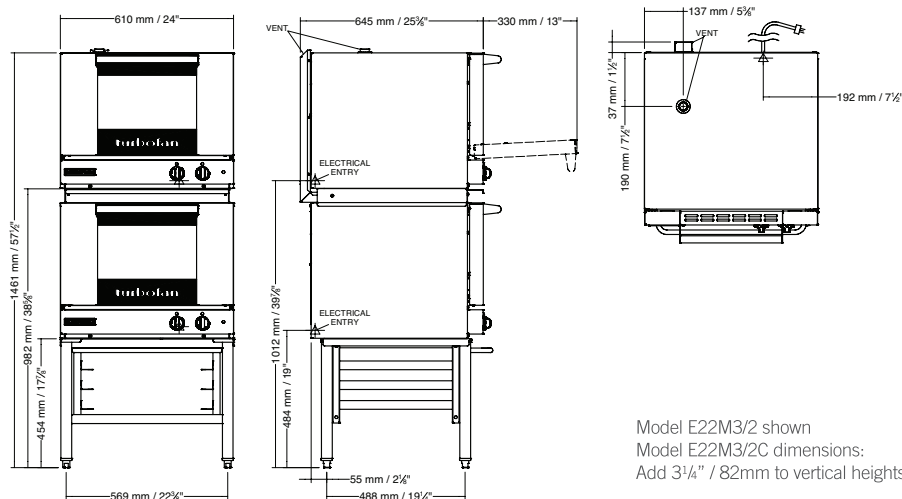

Model E22M3/2 shown
Model E22M3/2C dimensions:
Add 3¼" / 82mm to vertical heights



www.moffatusa.com
www.turbofanoven.com

U.S.A.

Moffat Inc
3765 Champion Boulevard
Winston-Salem
North Carolina 27105
Ph Toll Free 1-800-551 8795
Ph 336-661 0257
Fax 336-661 9546
Email sales@moffat.com
www.moffatusa.com

Manufactured by:
Moffat Limited
45 Illinois Drive, Izone Business Hub
Rolleston 7675, New Zealand



ISO9001
Quality
Management
Standard

Designed and manufactured by



ISO9001

All Turbofan products are designed and
manufactured by Moffat using the
internationally recognised ISO9001
quality management system, covering
design, manufacture and final inspection,
ensuring consistent high quality at all times.

In line with policy to continually develop
and improve its products, Moffat Limited
reserves the right to change specifications
and design without notice.



© Copyright Moffat Ltd
US.TFN.S.1601