

www.fogelusa.com



Ice Merchandisers

- Exterior cabinet made of white vinyl clad steel
- Custom front trim enhances cabinet appearance, Sturdy, stainless steel top
- Hinged door with chrome plated hardware, seals magnetically
- Reinforced, 16 gauge galvanized steel base
- Strong body with thick walls, injected with CFC free polyurethane foam
- Heavy duty galvanized steel interior with air distribution channels
- High capacity blower cooled refrigeration system with automatic defrost
- Forced-air condenser made of copper and aluminum, resistant to rust and saline environments
- Graphics are visible on three sides for maximum merchandising effect
- Steel edge trim provides extra protection on corner of each unit



Model No.	Description	Size D x L x H	Voltage	Amps	HP	Cubic Feet	Est. Ship Wt
ICB-1	1 Solid Door	36.25" x 55.5" x 75.75"	115	10.0	1/3	47	475#
ICB-2	2 Solid Doors	36.25" x 76.25" x 75.75"	115	12.0	1/2	60	635#
ICB-2-L <i>formally ICB-100</i>	2 Solid Doors	36.25" x 96" x 75.75"	115	12.0	1/2	85	733#
ICB-1-Slant	1 Solid Door Slanted	34.25" x 47.75" x 74"	115	10.0	1/3	40	422#

Fogel USA

831 Easy Cayuga St • Philadelphia, PA 19124 • 1-800-344-8222 • 1-215-464-6800
 Fax: 1-215-969-4890 • Email: sales@fogelusa.com • www.fogelusa.com

Excell Marketing Group

Ice Merchandisers



Technical Data

Model #	ICB-1	ICB-2	ICB-2-L	ICB-1-Slant
Outside Dimensions				
Depth	36.25"	36.25"	36.25"	34.25 "
Length	55.5"	76.25	96"	47.75"
Height	75.75"	75.75"	75.75"	74"
Door Size				
Door Type	1 swing	2 swing	2 swing	1 swing
Inside Dimensions				
Depth	30"	30"	30"	30.5"
Length	51"	72"	92"	43.5"
Height	55.5"	55.5"	55.5"	54"
# of 7lb bags	150	225	300	125
Capacity: Cubic Foot	47	60	85	40
Specifications				
Operating Temperature	23°F-30°F	23°F-30°F	23°F-30°F	23°F-30°F
Refrigerant	R-134a	R-134a	R-134a	R-134a
Compressor Size HP	1/3	1/2	1/2	1/3
Defrost	3@30min	3@30min	3@30min	3@30min
Voltage	115	115	115	115
Amperage	10.0	12.0	12.0	10.0
Cord and Plug	yes	yes	yes	yes
Shipping Dimensions				
Depth	39.25"	39.25"	39.25"	39.25"
Length	59.25"	80"	101"	80"
Height	79"	79"	79"	79"
Gross Weight lbs.	475	635	733	422

- Specification subject to change without notice.



831 E Cayuga Street, Philadelphia, PA 19124 USA • (215) 464-6800 • 1-800-344-8222
 Fax (215) 969-4890 • E-Mail: sales@fogelusa.com • www.fogelusa.com

FOGEL GROUP USA, LLC

www.fogelusa.com



Indoor Ice Merchandisers



- Exterior cabinet made of white vinyl clad steel
- Custom front trim enhances cabinet appearance, Sturdy, stainless steel top
- Hinged door with chrome plated hardware, seals magnetically
- Reinforced, 16 gauge galvanized steel base
- Strong body with thick walls, injected with CFC free polyurethane foam
- Heavy duty galvanized steel interior with air distribution channels
- High capacity blower cooled refrigeration system with automatic defrost
- Forced-air condenser made of copper and aluminum, resistant to rust and saline environments
- Graphics are visible on three sides for maximum merchandising effect
- Steel edge trim provides extra protection on corner of each unit
- Fully visible glass doors enhance your display
- The interior is provided with a lighting system to maximize visibility
- Equipped with heated Safety Glass

Model No.	Description	Size D x L x H	Voltage	Amps	HP	Cubic Feet	Est. Ship Wt
ICB-1-GL	1 Glass Door	36.25" x 55.5" x 75.75"	115	10.0	1/3	47	494#
ICB-2-GL	2 Glass Doors	36.25" x 76.25" x 75.75"	115	12.0	1/2	60	658#
ICB-2-L-G	2 Glass Doors	36.25" x 96" x 75.75"	115	12.0	1/2	85	774#

formally ICB-100-GL

Fogel USA

831 Easy Cayuga St • Philadelphia, PA 19124 • 1-800-344-8222 • 1-215-464-6800
 Fax: 1-215-969-4890 • Email: sales@fogelusa.com • www.fogelusa.com

Excell Marketing Group

Indoor Ice Merchandisers



Technical Data

Model #	ICB-1-GL	ICB-2-GL	ICB-2-L-G
Outside Dimensions			
Depth	36.25"	36.25"	36.25"
Length	55.5"	76.25"	96"
Height	75.75"	75.75"	75.75"
Door Size			
Door Type	1 swing	2 swing	2 swing
Inside Dimensions			
Depth	30"	30"	30"
Length	51"	72"	92"
Height	55.5"	55.5"	55.5"
# of 7lb bags	150	225	300
Capacity: Cubic Foot	47	60	85
Specifications			
Operating Temperature	23°F-30°F	23°F-30°F	23°F-30°F
Refrigerant	R-134a	R-134a	R-134a
Compressor Size HP	1/3	1/2	1/2
Defrost	3@30min	3@30min	3@30min
Voltage	115	115	115
Amperage	10.0	12.0	12.0
Cord and Plug	yes	yes	yes
Shipping Dimensions			
Depth	39.25"	39.25"	39.25"
Length	59.25"	80"	101"
Height	79"	79"	79"
Gross Weight lbs.	494	658	774

- Cases are designed to operate at 75° Fahrenheit and 55% relative humidity.
- Specification subject to change without notice.



831 E Cayuga Street, Philadelphia, PA 19124 USA • (215) 464-6800 • 1-800-344-8222
 Fax (215) 969-4890 • E-Mail: sales@fogelusa.com • www.fogelusa.com

FOGEL GROUP USA, LLC



ICB-1 and ICB-2 Side View - Plan View

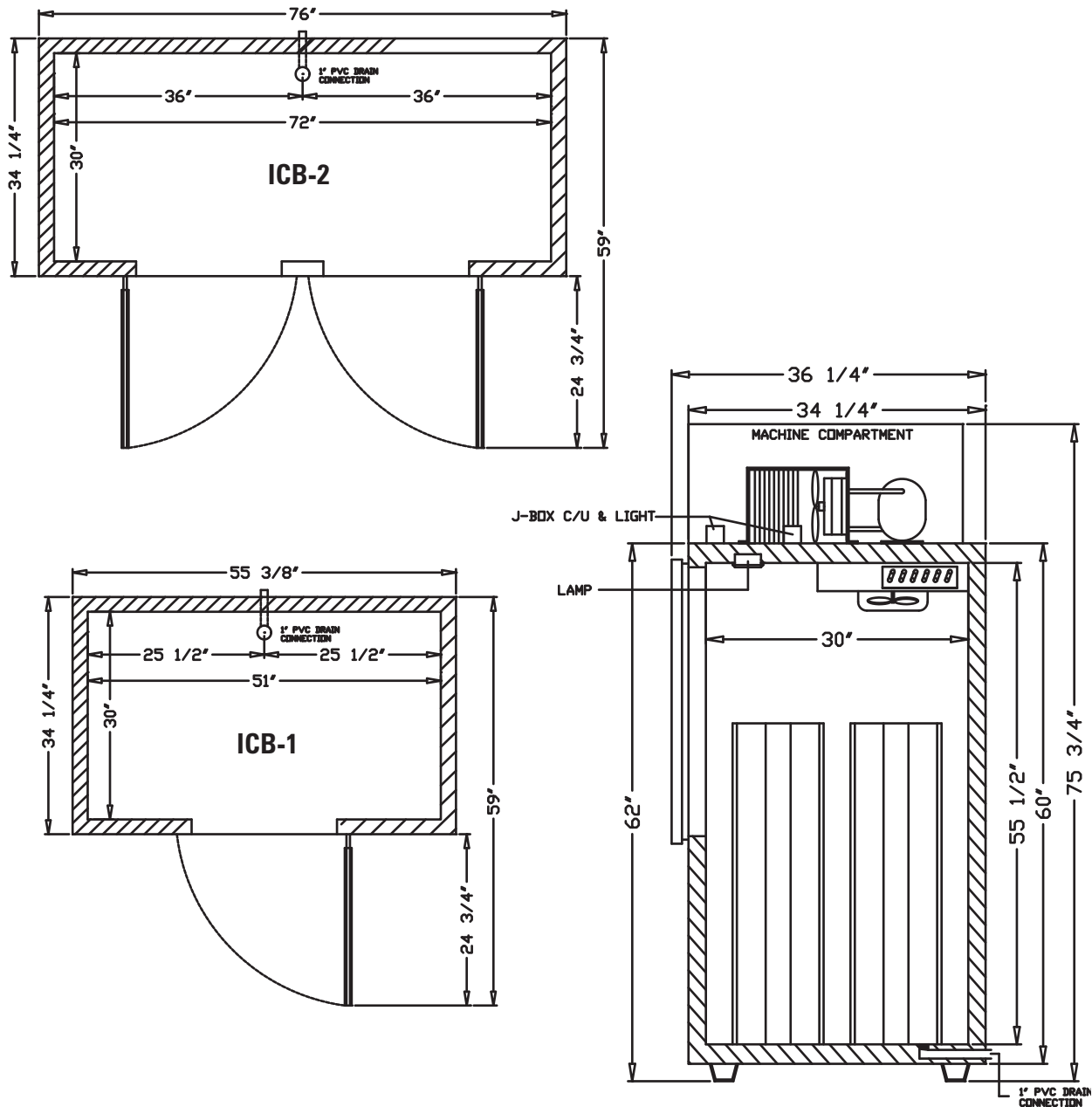

• Specification subject to change without notice.

FOGEL GROUP USA, LLC

831 E Cayuga Street, Philadelphia, PA 19124 USA • (215) 464-6800 • 1-800-344-8222
Fax (215) 969-4890 • E-Mail: sales@fogelusa.com • www.fogelusa.com





ICB-1-GL and ICB-2-GL Side View - Plan View

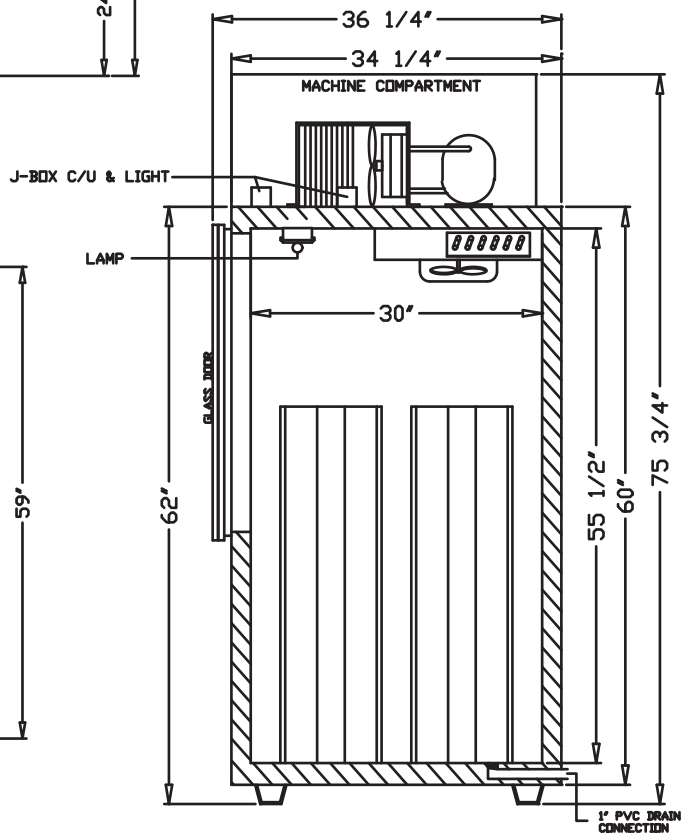
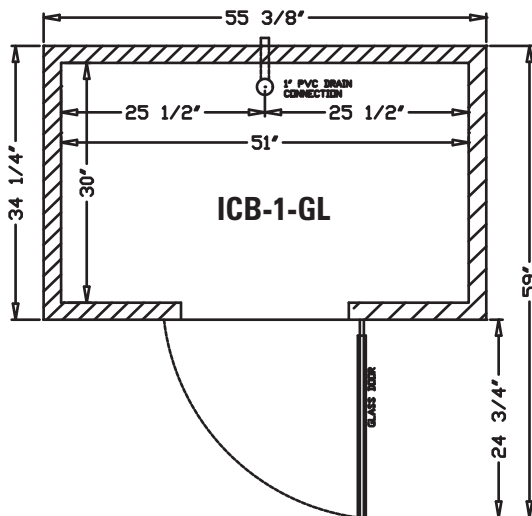
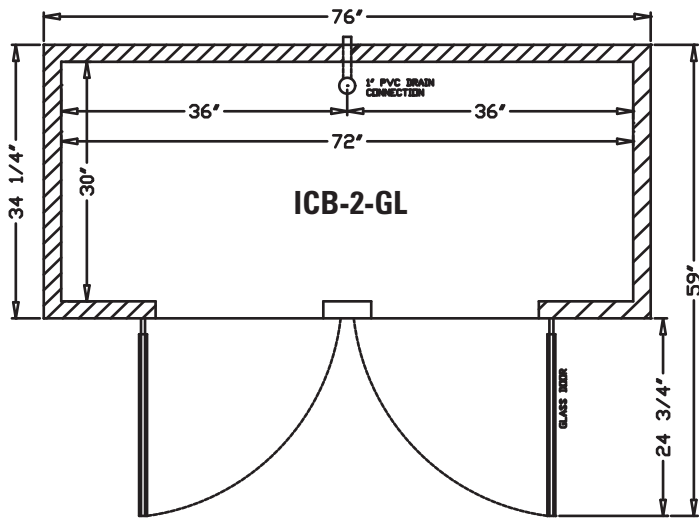

• Specification subject to change without notice.

FOGEL GROUP USA, LLC

831 E Cayuga Street, Philadelphia, PA 19124 USA • (215) 464-6800 • 1-800-344-8222
Fax (215) 969-4890 • E-Mail: sales@fogelusa.com • www.fogelusa.com

