

RM95

INDUSTRIAL DEHUMIDIFIER

OWNER'S MANUAL

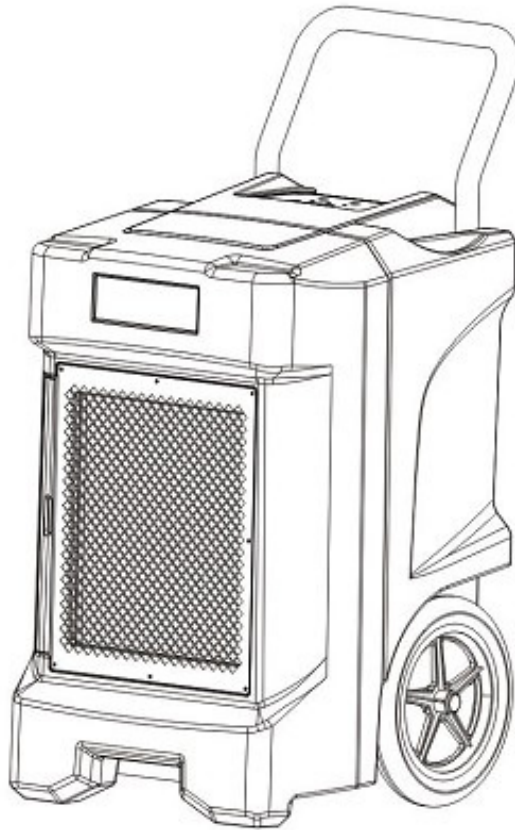



Drawing	: - TPC383
Issue	: - 2
Date	: - 03/10/12

RM95

PACKAGE CONTENTS

Item	Description	Quantity
10530GR-US	Dehumidifier	1
TPC383	Manual	1



Drawing	: - TPC383
Issue	: - 2
Date	: - 03/10/12

1. Product Introduction:



The unit can remove moisture from the air based on the principle of Steamily Refrigerating Compression. It can help to keep carpets, floors, walls, and other articles in the building dry, and it also can be used in file rooms, underground projects, commodity storage, medicine and health care where need a dry environment, the dehumidifier can prevent them from damp and mildew.

2. Packing list

One dehumidifier, one handle and two handle covers, six bolts for fixing handle, and one instruction manual.

3. Important Notice

CAUTION

- 
DO NOT
- 
DO NOT DO WITH WET HANDS
- 
FOLLOW THE INSTRUCTIONS

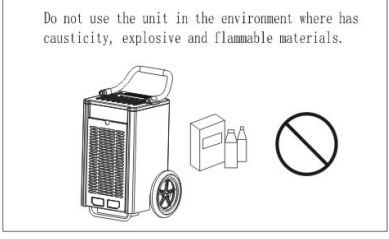
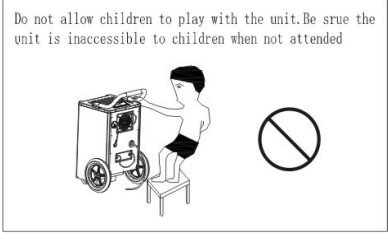
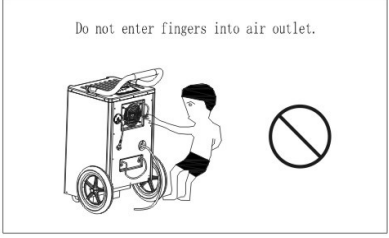
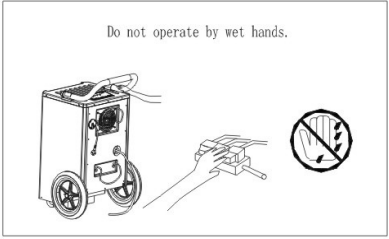
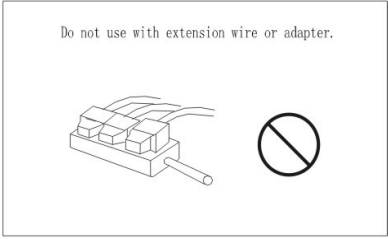
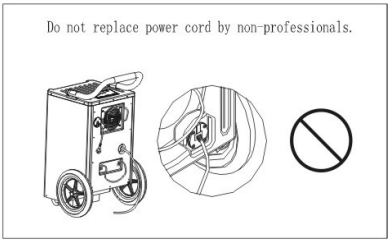
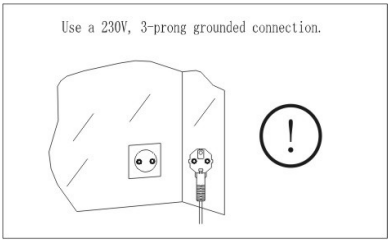

5. Operation Panel:

On/Off
Purge by hand
Display working time
Indicate the status
Time showing

ON/OFF:

Press once to turn the unit on or off.

PURGE:

Press the PURGE key to empty water from the pump reservoir. The pump will stop automatically after forty seconds continuous operation. During normal operation the pump purges automatically when the reservoir is full. And during purge condition, if the bottom is pressed once again, the pump will stop draining. Please press "PURGE" to make drainage before moving the machine to avoid water spillage.

T: Display working hours and totally working time

After turning on operation, it can display working hours for the current time, and the time unit is based on minutes, for example, if it displays "0000:50", it means that it has worked for 50 minutes this time. If you want to view the totally working time, please press "T" once more, and it will shows for 10s and returns automatically to the original working hours. If you press "T" before it has lasted for 10s, it also can turn to the original working hours.

If the unit is in power but not in operation, LED will displays nothing, and in this condition, the working hours at the last time will be showed for 10s if "T" is pressed one time. But within 10s, if "T" is pressed again, the totally working time will be showed for also 10s, and within 10s, if there is no action, LED will automatically turn down. In addition, if "T" is pressed again when LED displays the totally working time, LED will turn down immediately. What's more, the current working time will be deleted by pressing "T" for 5s continuously, and the time will be recounted, but the deleted time will be added into the totally working time.

Note: The totally working time can not be deleted, if the time is beyond the range of LED showing time, it will be deleted and recount from the start.

6. Preparation before use

Position of the dehumidifier: Place the dehumidifier in the middle of a room away from walls which shows below:

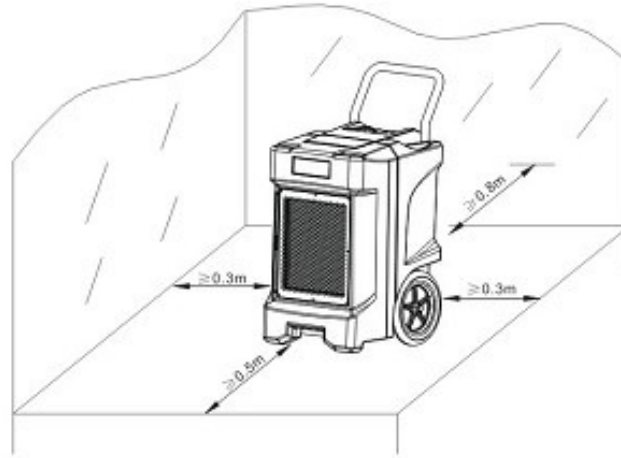

Use a 115V electrical outlet.

necessary for

Unwrap the entire hose. Do not leave any portion of the hose coiled on the unit, or obstructions that would restrict the flow of water.

Place the unattached end in a sink, drain, bucket or even outside; anywhere that water can drain out safely

The position of drain water pipe should not be too high (≤ 5 meters). Failure to do so may cause water backup in the pump resulting in leakage.

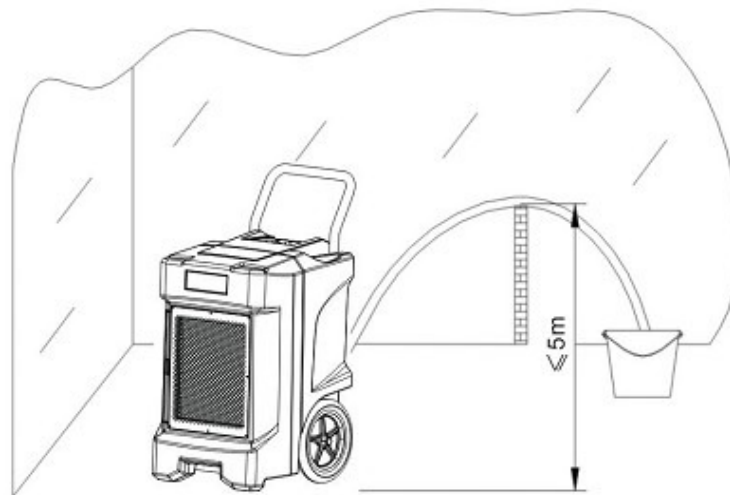

Plug in electrical outlet reliably, and solidly.

Make sure there is no any objects before the air outlet and air input, for it will reduce the function of the dehumidifier and higher electric charge.

7. Operating instructions

Operation for general use:

Press the ON/OFF key to turn the unit on, it will go into working mode automatically.

After using, press ON/OFF key to turn the unit off, while water pump will turn on automatically for 40 seconds to drain the rest water and turn off automatically.

Note:

During normal operation, do not disconnect the machine by directly removing the plug from the power. Otherwise the rest water will remain in the machine.

Do not move the machine at least three minutes after it stops running; it needs time for all the drops on the evaporator inflow into water tank. Moving it at once may make the drop fall onto ground and get the ground wet.

key lock function:

If the keys of "T" and "purge" are pressed for 2s at the same time, the defrost light will keep shining at the speed of 50Hz, and all the keys on the control panel will be in lock, but it can be unlock by the same action again.

Stack function:

For convenient freight, two unit of this machine could be stacked, and the slot of the wheel can help to stable and safe transportation.



Pipe function:

As to a much wetter space, use a plastic pipe with diameter larger than 170mm, and tie the pipe to hood, it will be much faster and more effective to make it dry.

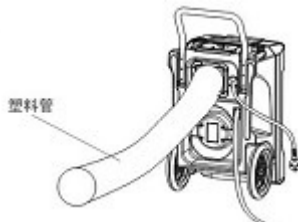

Warning: please cut the power before maintenance.

Clean air filter:

Ash on the filter will block the air hole, and it will impact the performance of dehumidifier. So filter is needed to clean regularly.

If the machine is used in a place which have lots of ash, you must clean it every 1~5 days.

If the machine is used in a clean place, you can wash the filter every one month.

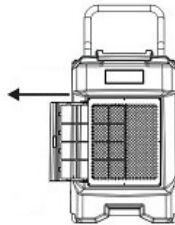

The way of washing filter:

Pull the filters out.

Using cleaner to wash the ash on filter. You can also use warm water (below 40°C) to wash filter

Dry the filter after washing then install it back to machine.

Note: Do not boil the filter or put it under sunshine.

Check drain hose:

An unimpeded drain hose can assure the drainage of water, so it is necessary to check the hose in case of obstruction. If the hose is deflated and can't recover, you must replace a new pipe.

If do not use the machine for a long time, please drain the inner water and pull out the power supply.

Replacement of battery:

The battery needs to be replaced if LED is not displayed when the unit is not on power.

Cut the power and unload the four bolts.

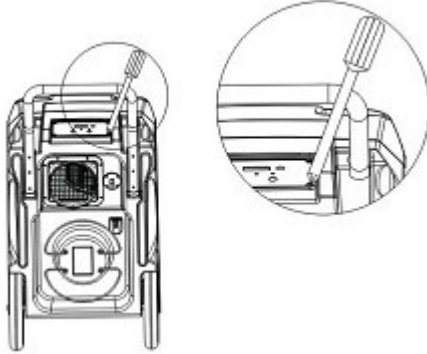

Take out the control panel, lightly pull electric cord.

Replace the battery with the specification of 6F22 9V.

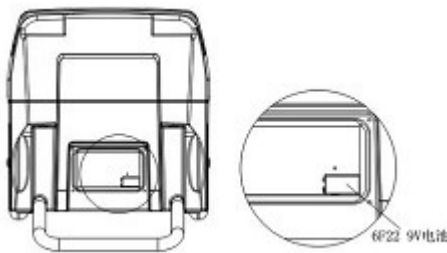

Reinstate the machine, and connect to the power. It can preserve its battery life if you turn on the machine as soon as replace it.



Warnings:

Drawing	: - TPC383
Issue	: - 2
Date	: - 03/10/12

Do not operate dehumidifier near heat source like burner, heater, or this can cause damage to both person and machine.

Do not use dehumidifier on the place where water may spatter to machine.

Before using, the machine should be put steadily to avoid damage.

To control the humidity carefully when you use the dehumidifier in the place where have wood furniture and floor, because over-dry environment may make the wood cracking.

Wildly shaking, crashing and high-angle incline may damage the machine: like the noise becomes louder etc. And the high-angle incline may cause the remained water of machine to leak out.

9. Trouble Shooting:

The problems as blow are probably not the real faults. Please check the machine according to the tips.

PROBLEM	CAUSE	SOLUTION
Unit does not operate	No power is connected to machine	Take down the plug from the power; and check the power
	Unit is not turned on	Press the key of "On" to turn on the machine
	E4 is exist	Try to use manual drainage
Unit collects little water even no water	Not enough time for working	Allow more time for drying
	Filter is blocked	Clean the filter
	Indoor temperature is too low	The dehumidifying volume is little under low ambient temperature ($\leq 18^{\circ}$), thus try to increase the indoor temperature
	Water pipe is tied or deflated	Check water pipe
Poor dehumidification	The door or windows are open; the bad hermetic house	Seal up the room
Leakage	The inner water do not drain clean or overbank of the unit	Use manual drainage after power is on
Hot air is drained from the outlet	The normal heat exchange	Normal phenomenon
With the sound of water flow or da da voice	The sound from refrigerant flowing or water pump working	Normal phenomenon

Notice: After check the above mentioned, if there is still a problem, please contact with local distributor. Please do not tear down or mend the machine by yourself.

Faults code:

When the screen displays error as follow, please contact with local distributor.

Code	E1	E3	E4
Error message	Coil sensor error	Lack or leakage of refrigerant; the compressor is out of normal operation	Water pump error ,water pipe block up or water level switch gets bad
Display usage	Flash once every 30 seconds	Flash continually	Flash continually
Explain	The machine is in normal working condition, and entering into timing defrost mode	Turn off machine. Then turn on again. Repeat the course mentioned above.	Machine turns off automatically. It cannot work unless the fault is solved

Specifications:

Name	Dehumidifier
Model	RM95
Power Supply	115V 60Hz
Max. Dehumidify Capacity(L/day) 30□ ,RH 80%	90
Rated Dehumidify Capacity(L/day) 27□ ,RH 60%	50
Max. Input Power(W)	1100
Rated Input Power (W)	860
Max. Current (A)	9.5
Rated Current (A)	7.5
Max. Working Pressure (MPa)	4.0
Heat Exchanger Pressure (MPa)	6.5
Refrigerant/Added weight	R410a/720g
Weight (kg)	45
Package Dimension (mm)	515*530*830
Working Temperature (°C)	0~45
Proper Collocate for House (m2)	60~90

Take the above data as the reference; please take the nameplate as the final parameter.

UK Head Office

Ebac Industrial Products Ltd
St Helens Trading Estate
Bishop Auckland
County Durham
DL14 9AD

Tel: +44 (0) 1388 664400
Fax: +44 (0) 1388 662590

www.eipl.co.uk
sales@eipl.co.uk

American Sales Office

Ebac Industrial Products Inc
700 Thimble Shoals Blvd.
Suite 109, Newport News
Virginia, 23606-2575
USA

Tel: +01 757 873 6800
Fax: +01 757 873 3632

www.ebacusa.com
sales@ebacusa.com

German Sales Office

Ebac Industrial Products Ltd
Miraustra 64 – 66
13509
Berlin
Germany

Tel: +49 3043 557241
Fax: +49 3043 557240

www.eip-ltd.de
sales@eip-ltd.de