



SCR1841BADA



31.75" x 17.75" x 23.5" (H x W x D)

18" wide ADA compliant glass door refrigerator for built-in or freestanding use, with digital controls, lock, and LED light

Highlights:

32" height allows installation under lower ADA compliant counters

Less than 18" wide for a perfect fit

Flexible design allows built-in or freestanding use under counters

Digital thermostat offers precise and convenient temperature control

Product Features:

ADA compliant	32" height is designed to fit under lower ADA compliant counters
Built-in capable	Make the best use of space by installing your appliance under the counter
Glass door with stainless steel trim	Provides a full display of stored contents with a heat-safe double tempered design
Factory installed lock	Keyed security on the door
Digital thermostat	Electronic controls for precise temperature management.
Digital display	Temperature readout can be shown in Celsius or Fahrenheit
LED lighting	Gentle illumination with an on/off switch
Automatic defrost	Reduced maintenance with the convenience of auto defrost
Adjustable chrome shelves	Rearrange interior space to accommodate all sizes or remove shelves for simple cleanup



SUMMIT APPLIANCE DIVISION FELIX STORCH, INC.

770 Garrison Avenue, Bronx, NY 10474 USA TEL 718-893-3900 FAX 844-478-8799 info@summitappliance.com  www.summitappliance.com



SCR1841BADA Specifications:

Overview	
Height	31.75"
Width	17.75"
Depth	23.5"
Depth with Handle	25.25"
Depth with door at 90°	39.75"
Capacity	2.7 cu.ft.
Defrost Type	Automatic
Door	Glass
Cabinet	Black
US Electrical Safety	CSA
Energy Usage/Year	284.0kWh/year
Amps	2.0
Voltage/Frequency	115 V AC/60 Hz
Weight	85.0 lbs.
Shipping Weight	95.0 lbs.
Parts & Labor Warranty	1 Year
Compressor Warranty	5 Years
Refrigerator Features	
Door Swing	RHD
Reversible	Yes
Shelf Type	Chrome
Shelf Qty	4
Adjustable Shelves	Yes
Thermostat Type	Digital
Fan Type	Interior and Exterior
Refrigerant Type	R600a
Refrigerant Amount	1.06oz.
High Side PSI	150.0
Low Side PSI	50.0
Level Legs Qty	2
Interior Light	Yes
Dimensions	
Interior Height	21.5"
Interior Width	12.75"
Interior Depth	16.75"
Compressor Step Height	4.75"

Compressor Step Width

Compressor Step Depth

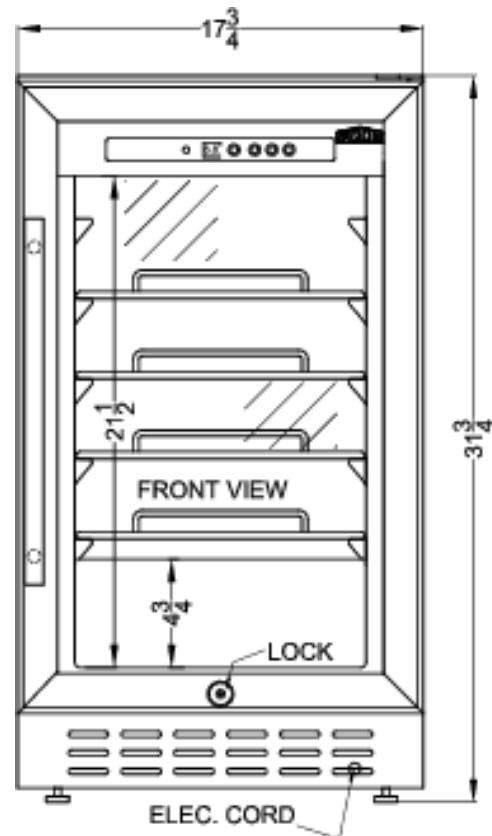
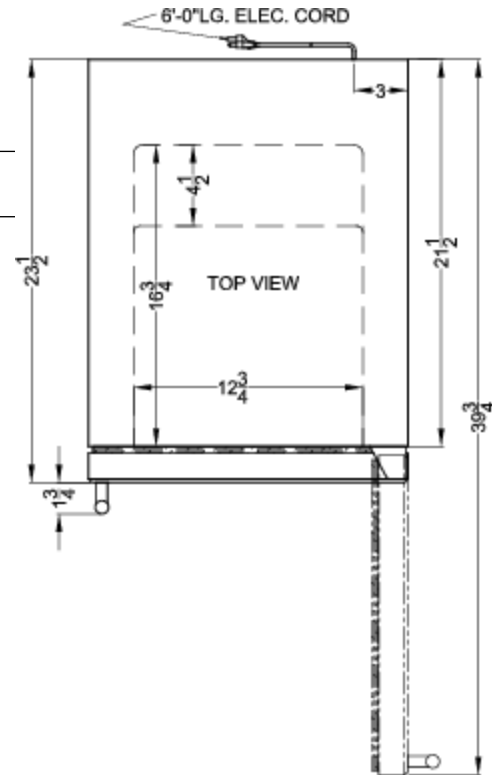

SUMMIT APPLIANCE DIVISION FELIX STORCH, INC.

770 Garrison Avenue, Bronx, NY 10474 USA TEL 718-893-3900 FAX 844-478-8799

info@summitappliance.com



www.summitappliance.com