

SERVICE MANUAL

AIRCONDITIONER

DC INVERTER MULTI TYPE

TAS-09MVHN

TAS-12MVHN

INDOOR VERTU DC INVERTER MULTI SERIES

CONTENTS

1. Precaution	1
1.1 Safety Precaution	1
1.2 Warning	1
2. Function	6
3. Dimension	7
4. Wiring Diagram	8
6. Electronic function	10
6.1 Abbreviation	10
6.2 Display function	10
6.3 Main Protection	11
6.4 Operation Modes and Functions	12

1. Precaution

1.1 Safety Precaution

- To prevent injury to the user or other people and property damage, the following instructions must be followed.
- Incorrect operation due to ignoring instruction will cause harm or damage.
- Before service unit, be sure to read this service manual at first.

1.2 Warning

➤ Installation

- Do not use a defective or underrated circuit breaker. Use this appliance on a dedicated circuit.

There is risk of fire or electric shock.

- For electrical work, contact the dealer, seller, a qualified electrician, or an authorized service center.

Do not disassemble or repair the product, there is risk of fire or electric shock.

- Always ground the product.

There is risk of fire or electric shock.

- Install the panel and the cover of control box securely.

There is risk of fire of electric shock.

- Always install a dedicated circuit and breaker.

Improper wiring or installation may cause fire or electric shock.

- Use the correctly rated breaker or fuse.

There is risk of fire or electric shock.

- Do not modify or extend the power cable.

There is risk of fire or electric shock.

- Do not install, remove, or reinstall the unit by yourself(customer).

There is risk of fire, electric shock, explosion, or injury.

- Be caution when unpacking and installing the product.

Sharp edges could cause injury, be especially careful of the case edges and the fins on the condenser and evaporator.

- **For installation, always contact the dealer or an Authorized service center.**

There is risk of fire, electric shock, explosion, or injury.

- **Do not install the product on a defective installation stand.**

It may cause injury, accident, or damage to the product.

- **Be sure the installation area does not deteriorate with age.**

If the base collapses, the air conditioner could fall with it, causing property damage, product failure, and personal injury.

- **Do not let the air conditioner run for a long time when the humidity is very high and a door or a window is left open.**

Moisture may condense and wet or damage furniture.

- **Take care to ensure that power cable could not be pulled out or damaged during operation.**

There is risk of fire or electric shock.

- **Do not place anything on the power cable.**

There is risk of fire or electric shock.

- **Do not plug or unplug the power supply plug during operation.**

There is risk of fire or electric shock.

- **Do not touch (operation) the product with wet hands.**

There is risk of fire or electric shock.

- **Do not place a heater or other appliance near the power cable.**

There is risk of fire and electric shock.

- **Do not allow water to run into electric parts.**

It may cause fire, failure of the product, or electric shock.

- **Do not store or use flammable gas or combustible near the product.**

There is risk of fire or failure of product.

- **Do not use the product in a tightly closed space for a long time.**

Oxygen deficiency could occur.

- **When flammable gas leaks, turn off the gas and open a window for ventilation before turn the product on.**

Do not use the telephone or turn switches on or off.

There is risk of explosion or fire.

■ **If strange sounds, or small or smoke comes from product. Turn the breaker off or disconnect the power supply cable.**

There is risk of electric shock or fire.

■ **Stop operation and close the window in storm or hurricane. If possible, remove the product from the window before the hurricane arrives.**

There is risk of property damage, failure of product, or electric shock.

■ **Do not open the inlet grill of the product during operation. (Do not touch the electrostatic filter, if the unit is so equipped.)**

There is risk of physical injury, electric shock, or product failure.

■ **When the product is soaked (flooded or submerged), contact an Authorized service center.**

There is risk of fire or electric shock.

■ **Be caution that water could not enter the product.**

There is risk of fire, electric shock, or product damage.

■ **Ventilate the product from time to time when operating it together with a stove, etc.**

There is risk of fire or electric shock.

■ **Turn the main power off when cleaning or maintaining the product.**

There is risk of electric shock.

■ **When the product is not be used for a long time, disconnect the power supply plug or turn off the breaker.**

There is risk of product damage or failure, or unintended operation.

■ **Take care to ensure that nobody could step on or fall onto the outdoor unit.**

This could result in personal injury and product damage.

➤ **CAUTION**

■ **Always check for gas (refrigerant) leakage after installation or repair of product.**

Low refrigerant levels may cause failure of product.

■ **Install the drain hose to ensure that water is drained away properly.**

A bad connection may cause water leakage.

■ **Keep level even when installing the product.**

It can avoid vibration of water leakage.

■ **Do not install the product where the noise or hot air from the outdoor unit could damage**

the neighborhoods.

It may cause a problem for your neighbors.

- **Use two or more people to lift and transport the product.**

Avoid personal injury.

- **Do not install the product where it will be exposed to sea wind (salt spray) directly.**

It may cause corrosion on the product. Corrosion, particularly on the condenser and evaporator fins, could cause product malfunction or inefficient operation.

➤ **Operational**

- **Do not expose the skin directly to cool air for long periods of time. (Do not sit in the draft).**

This could harm to your health.

- **Do not use the product for special purposes, such as preserving foods, works of art, etc.**

It is a consumer air conditioner, not a precision refrigerant system.

There is risk of damage or loss of property.

- **Do not block the inlet or outlet of air flow.**

It may cause product failure.

- **Use a soft cloth to clean. Do not use harsh detergents, solvents, etc.**

There is risk of fire, electric shock, or damage to the plastic parts of the product.

- **Do not touch the metal parts of the product when removing the air filter. They are very sharp.**

There is risk of personal injury.

- **Do not step on or put anything on the product. (outdoor units)**

There is risk of personal injury and failure of product.

- **Always insert the filter securely. Clean the filter every two weeks or more often if necessary.**

A dirty filter reduces the efficiency of the air conditioner and could cause product malfunction or damage.

- **Do not insert hands or other object through air inlet or outlet while the product is operated.**

There are sharp and moving parts that could cause personal injury.

- **Do not drink the water drained from the product.**

It is not sanitary could cause serious health issues.

- **Use a firm stool or ladder when cleaning or maintaining the product.**

Be careful and avoid personal injury.

- **Replace the all batteries in the remote control with new ones of the same type. Do not mix old and new batteries or different types of batteries.**

There is risk of fire or explosion.

- **Do not recharge or disassemble the batteries. Do not dispose of batteries in a fire.**

They may burn or explode.

- **If the liquid from the batteries gets onto your skin or clothes, wash it well with clean water. Do not use the remote if the batteries have leaked.**

The chemical in batteries could cause burns or other health hazards

The designs, and information in this book are subject to change without notice for product improvement

2. Function

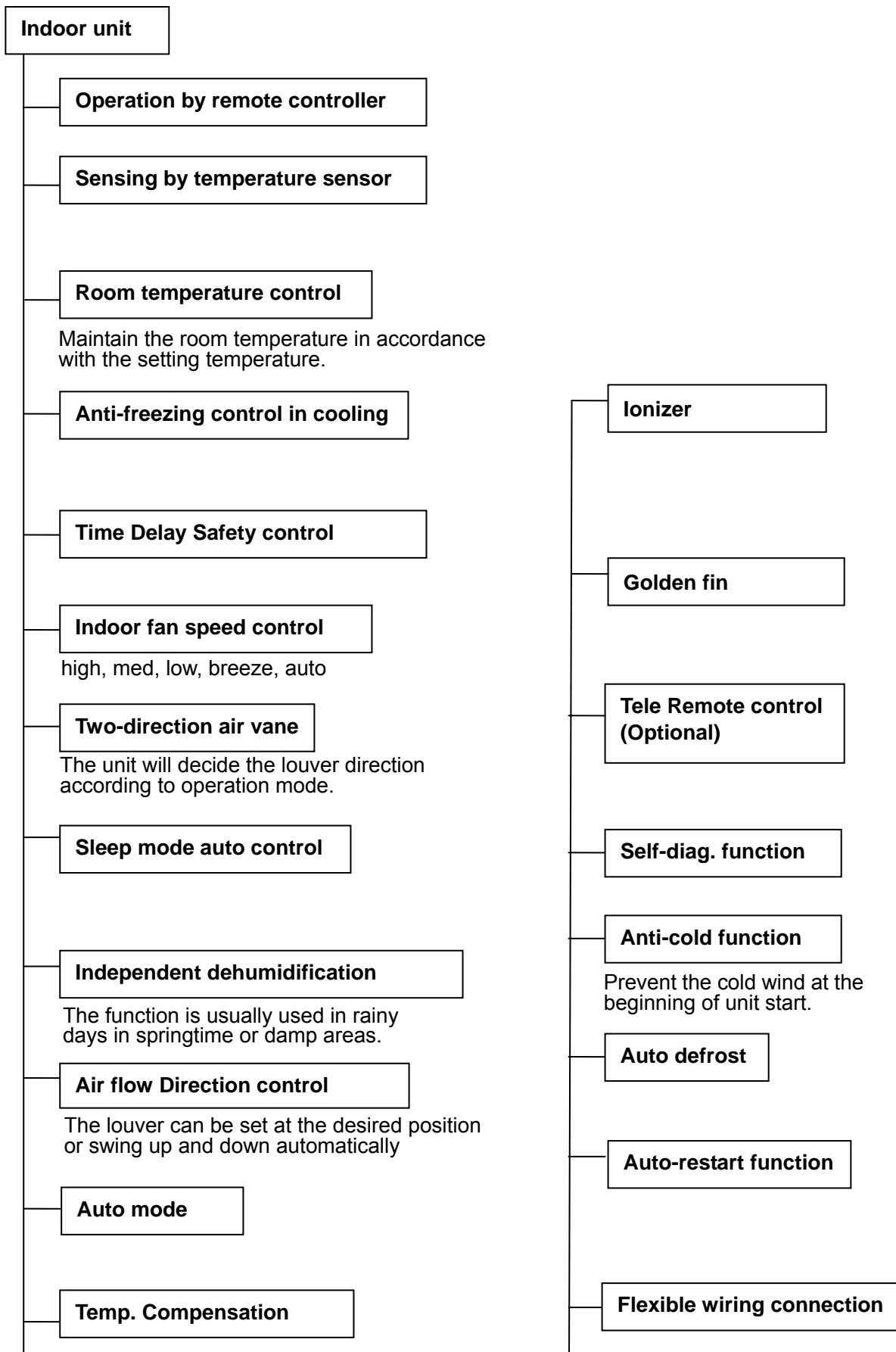

3. Dimension

Dimension of indoor unit

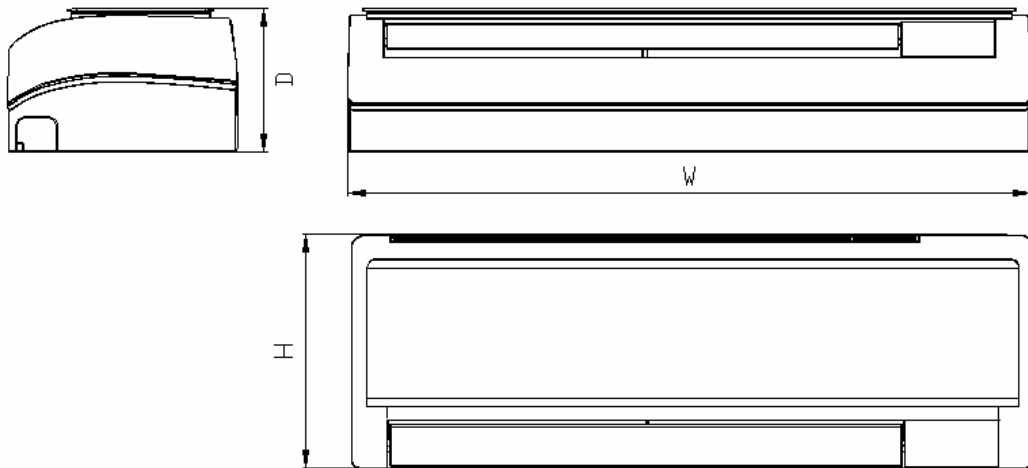

Model \ Dimension	W	H	D
TAS-09MVHN	795 mm 31.30 inch	270 mm 10.63 inch	165 mm 6.5 inch
TAS-12MVHN	845 mm 33.27 inch	286 mm 11.26 inch	165 mm 6.5 inch

Position of installation board

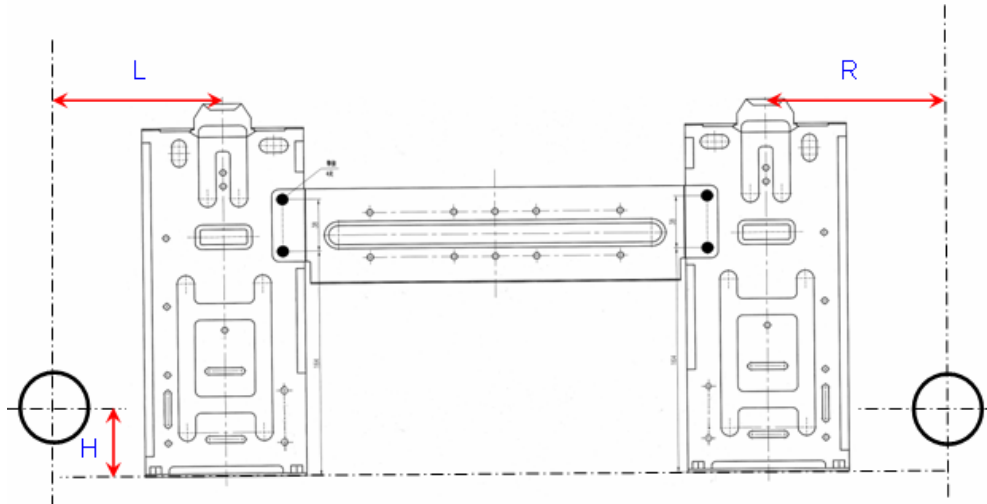

Model	R	L	H	Dimension of installation hole
TAS-09MVHN	160 mm 6.28 inch	150 mm 5.91 inch	45 mm 1.77 inch	φ 65 mm 2.56 inch
TAS-12MVHN	186 mm 7.32 inch	150 mm 5.91 inch	45 mm 1.77 inch	φ 65 mm 2.56 inch

4. Wiring Diagram

Indoor unit (TAS-09MVHN / TAS-12MVHN)

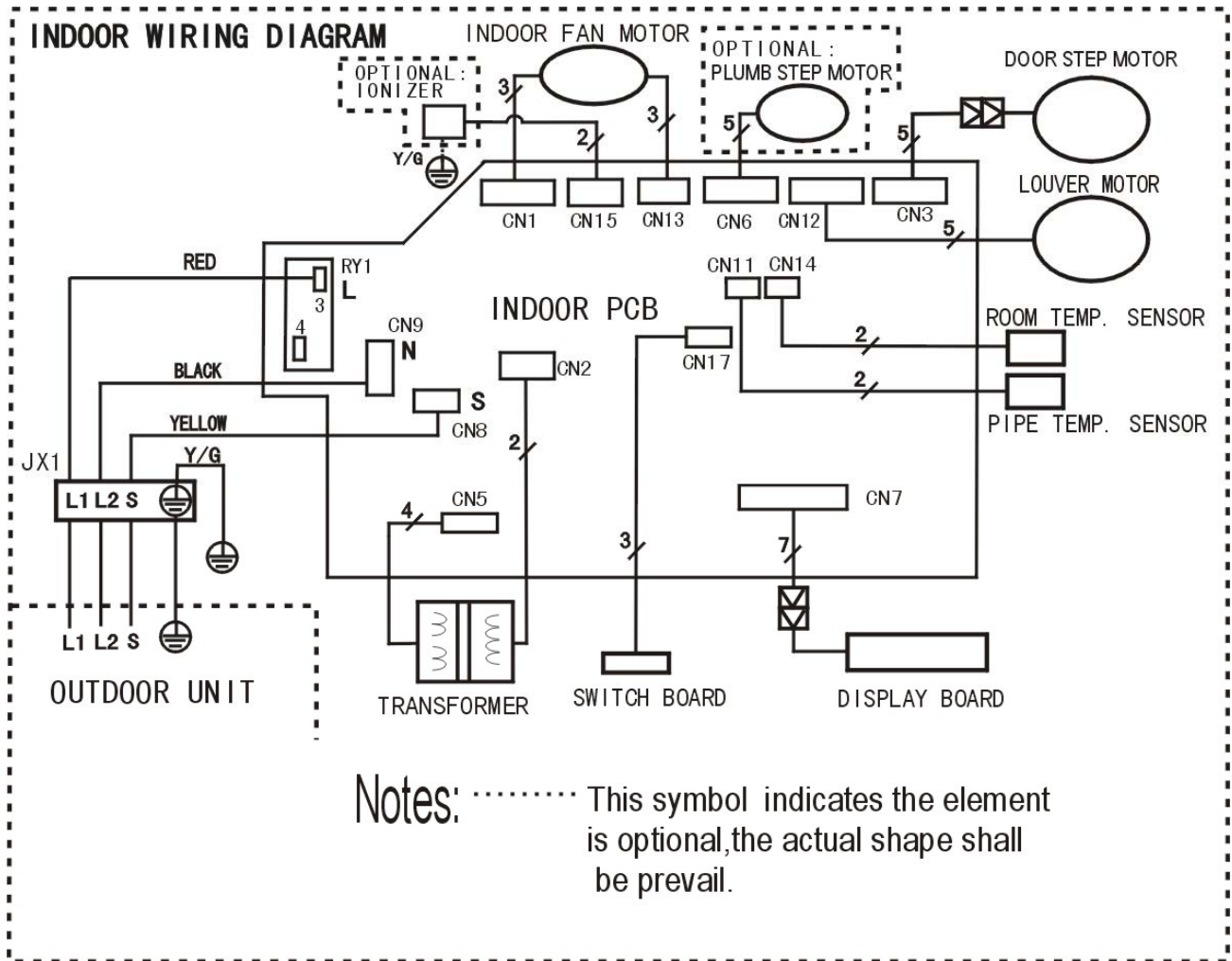

5. Operation characteristics

Mode Temperature	Cooling operation	Heating operation	Drying operation
Room temperature	≥62°F (16.7°C)	≤86°F (30°C)	>50°F (10°C)
Outdoor temperature	32°F (0°C)~122°F(50°C)	5°F (-15°C)	32°F(0°C)
	(5°F~122°F:For the models with low temperature cooling system)	~ 83°F (28.3°C)	~ 122°F(50°C)

CAUTION:

1. If air conditioner is used outside of the above conditions, certain safety protection features may come into operation and cause the unit to function abnormally.

2. Room relative humidity less than 80%. If the air conditioner operates in excess of this figure, the surface of the air conditioner may attract condensation. Please set the vertical air flow louver to its maximum angle (vertically to the floor), and set HIGH fan mode.

3. Optimum performance will be achieved within this operating temperature.

6. Electronic function

6.1 Abbreviation

T1: Indoor ambient temperature

T2: Coil temperature of indoor heat exchanger middle.

T2B: Coil temperature of indoor heat exchanger outlet.

T3: Coil temperature of outdoor heat exchanger

T4: Outdoor ambient temperature









T5: Compressor discharge temperature

Ts: Setting temp.

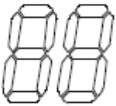
6.2 Display function

6.2.1 Icon explanation on indoor display board.



	<p>TIMER display Illuminated during Timer operation.</p>
	<p>CLEAN AIR display(optional) Illuminated when Ionizer is activated.</p>
	<p>TURBO operation display Illuminated when select TURBO function in cooling operation or in heating operation.</p>
	<p>DIGITAL DISPLAY Displayed the current setting temperature or malfunction code when the air conditioner is in operation. When SELF CLEAN feature is activated, it displays . "SC"</p>
	<p>FAN SPEED display Displayed the selected fan speed: LOW() , MED() and HIGH() .</p>
	<p>Operation Frequency display This display is separated into five zones. The zones illuminate based on the compressor current frequency. For example, higher frequency will illuminate more zones.</p>

6.3 Main Protection

6.3.1 Three Minutes Delay at restart for compressor.

6.3.2 Fan Speed is out of control.

----When Indoor Fan Speed keeps too low or too high for certain time, the unit will stop and the LED will display the failure

6.3.3 Indoor fan delayed open function

----When the system starts up, the louver will be active immediately and the indoor fan will open 10s later.

----If the system runs in heating mode, the indoor fan will be also controlled by anti-cold wind function.

6.3.4 Zero crossing detection error protection

6.4 Operation Modes and Functions

6.4.1 Fan mode.

- (1) The outdoor fan and compressor stop.
- (2) Temperature setting function is disabled, and no setting temperature is displayed.
- (3) Indoor fan can be set to high/med/low/auto.
- (4) The louver operates the same as in cooling mode.
- (5) Auto fan:

The action of auto fan in fan-only mode is the same as auto fan in cooling mode with 24°C / 75 F setting temperature.

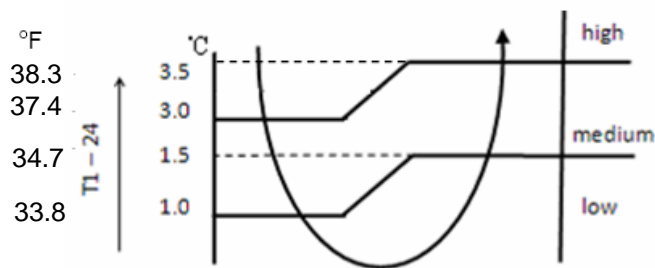

6.4.2 Cooling Mode

6.4.2.1 Compressor running rules:

The compressor will run at corresponding frequency according to the gross amendatory capacity demand.

Frequency(Hz)	0	COOL_F1	COOL_F2	COOL_F11	COOL_F12
Amendatory capacity demand.	0	1	2	11	≧ 12

Meanwhile the maximum running frequency will be adjusted according to the outdoor ambient temp.

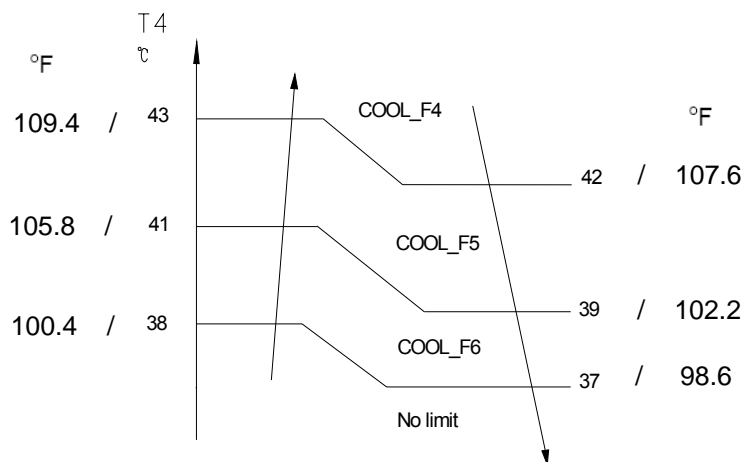

6.4.2.2 Indoor fan running rules

In cooling mode, indoor fan runs all the time and the speed can be selected as high, medium, low and auto.

Auto fan in cooling mode acts as follow:

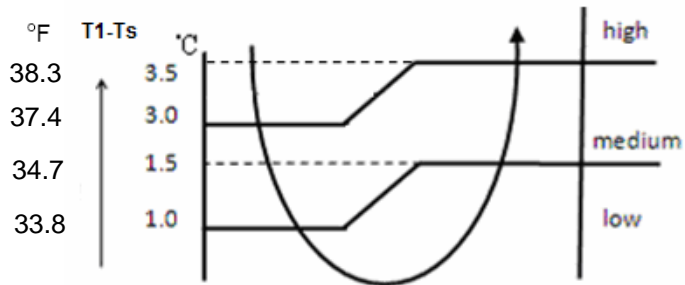

6.4.2.3 Evaporator low temperature T2 protection.

When $T_2 < 4$ °C / (39.2°F), the indoor has no capacity demand and resume till $T_2 > 8$ °C (46.4°F)

6.4.2.4 Outdoor fan running rules:

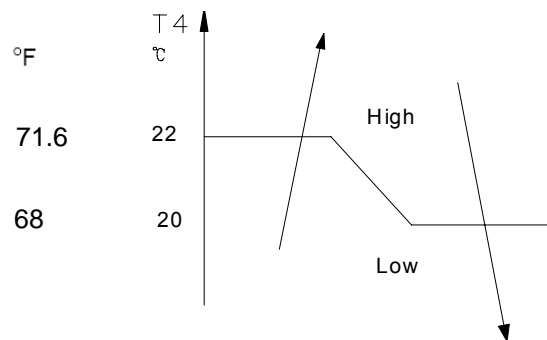

6.4.3 Heating Mode

6.4.3.1 Compressor running rules:

The compressor will run at corresponding frequency according to the gross amendatory capacity demand.

Frequency(Hz)	0	HEAT_F1	HEAT_F2	HEAT_F11	HEAT_F12
Amendatory capacity demand.	0	1	2	11	≥ 12

6.4.3.2 Indoor fan running rules:

Indoor fan speed can be set as high, medium, low or auto fan and the anti-cold-wind function is preferential.

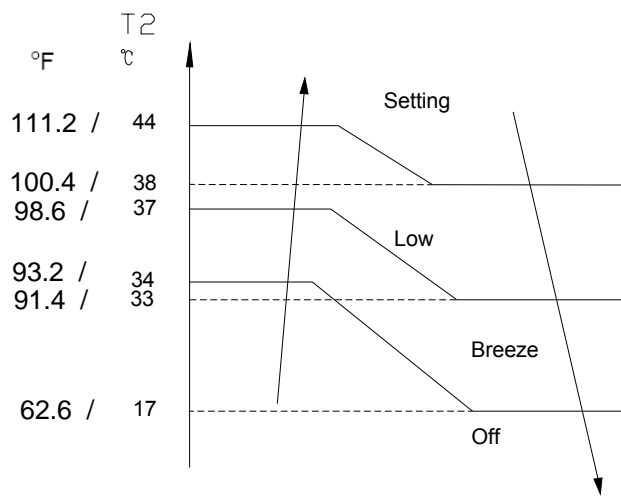

Auto fan action in heating mode.

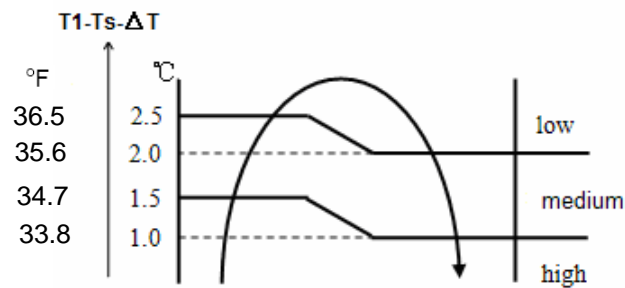

6.4.3.3 Outdoor fan running rules:

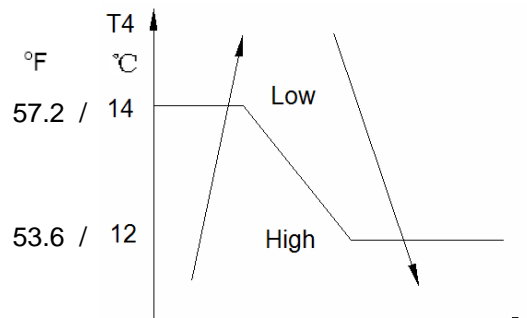

6.4.3.3 High evaporator coil temp.T2 protection:

If $T_2 > 63^\circ\text{C}$ (145.4°F) the indoor unit has no capacity demand and resume, till 48°C (118.4°F)

6.4.3.4 Defrosting mode:

Condition of defrosting:

$T_3 \leq T_{CDIN}$ and lasts for 40 minutes. $T_{CDIN} = -2^\circ\text{C}$ (28.4°F)

Defrosting action:

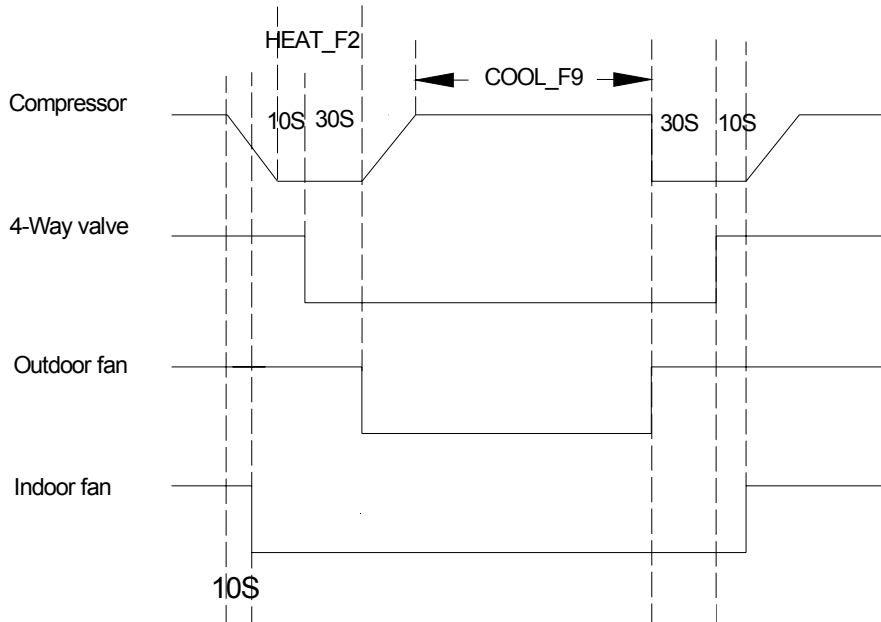

Condition of ending defrosting:

If any one of following items is satisfied, defrosting will stop and the machine will turn to normal heating mode.

- ① $T_3 > T_{CDE}$; $T_{CDE} = 15^\circ\text{C}$ (59°F)
- ② The defrosting time achieves 10min.

6.4.4 Auto-mode

This mode can be chosen by remote controller and the setting temperature can be changed between 17°C (62.6°F)~ 30°C (86°F).

In auto mode, the machine will choose cooling, heating or fan-only mode according to ΔT ($\Delta T = T_1 - T_s$).

$\Delta T = T_1 - T_s$	Running mode
$\Delta T > 1^\circ\text{C}$ (33.8°F)	Cooling
-1°C (30.2°F) $\leq \Delta T \leq 1^\circ\text{C}$ (33.8°F)	Fan-only
$\Delta T < -1^\circ\text{C}$ (30.2°F)	Heating

Indoor fan will run at auto fan of the relevant mode.

The louver operate same as in relevant mode.

If the machine switches mode between heating and cooling, the compressor will keep stopping for 15 minutes and then rechoose mode according to T1-Ts.

If the setting temperature is modified, the machine will rechoose running function.

6.4.5 Dehumidifier mode

6.4.5.1 Indoor fan speed is fixed at breeze and can't be changed. The louver angle is the same as in cooling mode.

6.4.5.2 Overlow room temperature protection

In dehumidifier mode, if room temperature is lower than 10°C (50°F), the indoor fan will stop and not resume until room temperature exceeds 12°C (53.6°F).

6.4.5.3 Evaporator anti-freezing protection are active

6.4.6 Forced operation function

6.4.6.1 Enter forced operation function:

Press the touch button continually, the AC will run as below sequence:

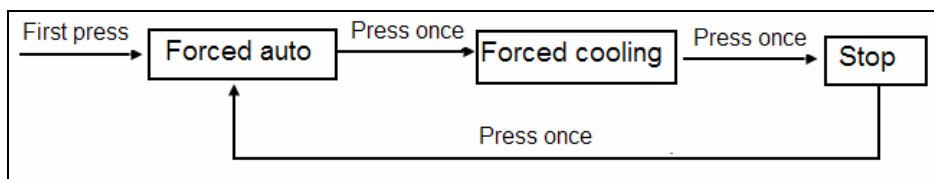

When the machine is off, pressing the touch button will carry the machine to forced auto mode, after this, if pressing the button once again, the machine will turn into forced cooling mode.

In forced cooling mode, pressing touch button will turn off the machine.

6.4.6.2 In forced operation mode, all general protections and remote control are available.

6.4.6.3 Operation rules:

Forced cooling mode:

The indoor fan runs as breeze. After running for 30 minutes, AC will turn to auto mode with 24°C (75.2°F) setting temperature.

Forced auto mode:

The action of forced auto mode is the same as normal auto mode with 24°C (75.2°F) setting temperature.

6.4.6.4 When there's indoor unit running in forced cooling, it is the master forced cooling unit. Other indoor units will run at forced cooling mode too and they will be the slave forced cooling unit. The slave forced cooling units can not quit forced cooling mode until the master forced cooling unit quit.

6.4.6.5 The slave forced cooling units will not be controlled by other signals except timer off signal.

6.4.6.6 If AC is running in sleep mode and receives forced operation signal, it will quit the sleep mode.

6.4.7 Timer function

6.4.7.1 Timing range is 24 hours.

6.4.7.2 Timer on. The machine will turn on automatically when reaching the setting time.

6.4.7.3 Timer off. The machine will turn off automatically when reaching the setting time.

6.4.7.4 Timer on/off. The machine will turn on automatically when reaching the setting “on” time, and then turn off automatically when reaching the setting “off” time.

6.4.7.5 Timer off/on. The machine will turn off automatically when reaching the setting “off” time, and then turn on automatically when reaching the setting “on” time.

6.4.7.6 The timer function will not change the AC current operation mode. Suppose AC is off now, it will not start up firstly after setting the “timer off” function. And when reaching the setting time, the timer LED will be off and the AC running mode has not been changed.

6.4.7.7 The setting time is relative time.

6.4.8 Sleep function mode

6.4.8.1 Operation time in sleep mode is 7 hours. After 7 hours the AC quits this mode and turns off.

6.4.8.2. Operation process in sleep mode is as follow:

When cooling, the setting temperature rises 1°C/33.8°F (be lower than 30°C / 86°F) every one hour, two hours later setting temperature stops rising and indoor fan is fixed as low speed.

When heating, the setting temperature decreases 1°C/33.8°F (be higher than 17°C / 62.6°F) every one hour, 2 hours later the setting temperature stops rising and indoor fan is fixed as low speed.

(Anti-cold wind function has the priority)

6.4.8.3 Timer off and remote controller off signals have the priority compared with sleep function.

6.4.8.4 When user uses timer off function in sleep mode(or sleep function in timer off mode), if the timing is less than 7 hours, sleep function will be cancelled when reaching the setting time. If the timing is more than 7 hours, the machine will not stop until reaches the setting time in sleep mode.

6.4.9 Auto-Restart function

The indoor unit is equipped with auto-restart function, which is carried out through an auto-restart module. In case of a sudden power failure, the module memorizes the setting conditions before the power failure. The unit will resume the previous operation setting (not including Swing function)

automatically after 3 minutes when power returns.

If the memorization condition is forced cooling mode, the unit will run in cooling mode for 30 minutes and turn to auto mode as 24°C (75.2°F) setting temp.

6.4.10 Ionizer/Plasma dust collector function (optional)

The indoor unit is equipped with Ionizer, which is controlled by the CLEAN AIR button on the remote controller. When the unit is turned on, press the CLEAN AIR button to activate the function. Press it again to stop the function. During the time when Ionizer is controlled by remote controller, Ionizer will be turned off automatically if indoor fan stops running due to malfunctions or anti-cold-wind. When indoor fan restarts after malfunctions being eliminated and anti-cold-wind being released, Ionizer will be available again.

6.4.11 Mode conflict

The indoor units can not work cooling mode and heating at same time.

Heating mode has a priority.

6.4.11.1 Definition:

	Cooling mode	Heating Mode	Fan	Off
Cooling mode	No	Yes	No	No
Heating Mode	Yes	No	Yes	No
Fan	No	Yes	No	No
Off	No	No	No	No

No: No mode conflict;

Yes: Mode conflict

6.4.11.2 Unit action

- Suppose Indoor unit A working in cooling mode or fan mode, and indoor unit B is set to heating mode, then A will change to stand by and B will work in heating mode.
- Suppose Indoor unit A working in heating mode, and indoor unit B is set to cooling mode or fan mode, then B will change to stand by and A will be no change.