

REFRIGERATOR MANUFACTURER
Turbo air
 more durable, efficient, beautiful

4184 E. Conant St.
 Long Beach, CA 90808
 Tel. 310-900-1000
 Fax. 310-900-1077
www.turboairinc.com

Project :	
Model # :	
Item # :	Qty :
Available W/H :	
Approval :	

Swing Door Merchandisers

Glass Door Merchandisers
 Super Deluxe Series

Model : TGM-7SD

FEATURES & BENEFITS

- **LED lighting interior display system**
 Brighter and longer lasting LED lights provide attractive, enhanced illumination compared to fluorescents. It saves energy by producing less heat, while maximizing the visibility in the display area.
- **Modern design**
 By harmonizing curvature and rigidity, our modern style product designs are user-friendly while maintaining the highest product visibility and aesthetics.
- **Double pane glass doors with Low-E glass**
 Energy saving double pane glass doors are equipped with Low-emissivity glass, which reduce outer heat gain and decrease energy consumption. It enhances energy efficiency and minimizes condensation. Lightweight door construction also reduce door maintenance and bushing wear, which in turn facilitates smoother door openings.
- **Efficient refrigeration system**
 Turbo Air's glass door merchandisers are designed with oversized and balanced (CFC Free R-134A) refrigeration systems. These include efficient evaporators and condensers for faster cooling and greater efficiency.
- **High-density polyurethane insulation**
 The entire cabinet structure is foamed-in-place using high density, CFC free polyurethane insulation.
- **Ergonomically designed doors**
 Customers' fatigue fades away with easy grip handles and doors that open effortlessly. These features along with self-closing doors make this the ultimate choice in customer convenience.
- **Magnetic door gaskets**
 Magnetic door gaskets are of one piece construction, removable without tools for ease of cleaning and replacement.
- **Adjustable, heavy duty, PE (polyethylene) coated wire shelves**
- **Refrigerator holds 33°F ~ 38°F for the best in beverage preservation**



Model	Swing Door	CU./FT.	#of Shelves	HP	AMPS	Crated Weight (lbs.)	L x D* x H† (inches)
TGM-7SD	1	7.6	3	1/7	3.5	202	25 x 23 1/4 x 38 1/8

Model : TGM-7SD

ELECTRICAL DATA	
Voltage	115/60/1
Plug Type	Ⓜ NEMA 5-15P
Full Load Amperes	3.5
Compressor HP	1/7
Cord Length (ft.)	9
Refrigerant	R-134A
DIMENSIONAL DATA	
# of Doors	1
Net Capacity (cu. ft.)	7.6
Ext. Length Overall (in.)	25 (635mm)
Ext. Depth Overall (in.)*	23 1/4 (590mm)
Ext. Height Overall (in.)†	38 1/8 (970mm)
Int. Length Overall (in.)	20 5/8 (525mm)
Int. Depth Overall (in.)	18 3/4 (475mm)
Int. Height Overall (in.)	33 7/8 (860mm)
Net Weight (lbs.)	171
Gross Weight (lbs.)	202
# of Shelves	3
Shelf Size (L x D) (in.)	19 3/8 x 16 5/8

Design and specifications subject to change without notice.
Actual shipping weight may differ due to extra packing materials for product protection.
* Depth does not include 2-1/4" for door handle.
* Depth does not include 2-3/8" for rear mechanical component and additional 1-5/8" for a power cord bushing & radius of curvature.
† Height does not include 2-1/4" (56mm) for leg height.

■ **WARRANTY : 3 Year Parts and Labor Warranty**
Additional 2 Year Warranty on Compressor

- **Door locking system standard**
- **Three color options available (standard):** white cabinet (W), white cabinet with wine color trim (V) or black cabinet with black color trim (B)

■ **OPTIONAL ACCESSORIES :**

- Additional PE coated wire shelf: P0178A0300
- Price tag channel: P0122K5700 (18 1/2"L)

PLAN VIEW

(unit : inch)

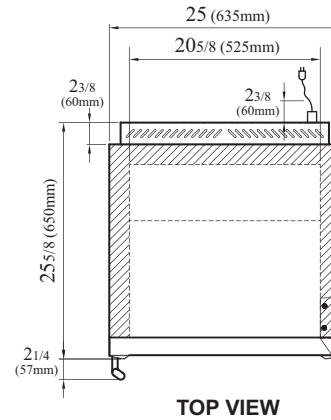

TOP VIEW

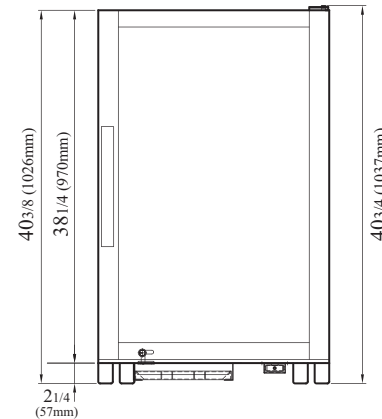

FRONT VIEW

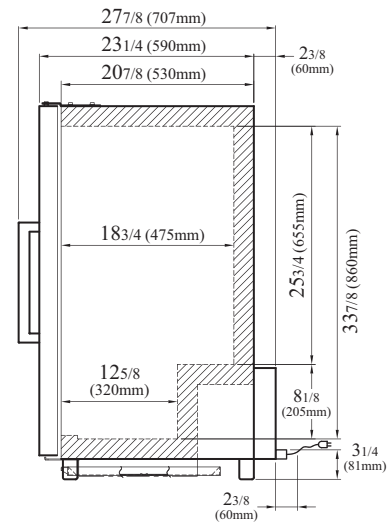

SIDE VIEW

Ver.201606



ENERGY STAR®
Qualified

- Turbo Air : 800-627-0032
- GK : 800-500-3519
- Warranty : 800-381-7770
- AC : 888-900-1002

