



FORWARD SEALING BEER FAUCETS
 U.S. PATENT #8066257



630SS

Perlick's Forward Sealing Beer Faucets are unique in both appearance and function. The revolutionary ball and floating O-ring design eliminates the need for a valve shaft. Beer is not exposed to air so the handle lever doesn't stick, and there is no build up of mold and bacteria in the faucet body. The polished interior produces a smooth flow with less foaming, ensuring a perfect pour each and every time. Fewer internal parts means better reliability and fewer service calls. This faucet will fit all standard North American shanks.



650SS Flow Control

Cleaning Instructions

Before using your new Perlick faucet, clean the faucet as you would for regular cleaning (see cleaning instructions below.) This will ensure that the faucet is clear of any materials that may be present from the manufacturing process.

We recommend that the faucet be cleaned when the beer system is cleaned. Regular cleaning of the faucet is extremely important. The faucet can be cleaned "in place" by simply pumping your cleaning solution through the beer system with the beer faucet in the opened position (handle forward). There is no need to remove or disassemble the faucet! By leaving the faucet installed, the cleaning solution will thoroughly clean all internal parts including the floating O-ring and its groove.

If your specific cleaning procedure requires removing the faucet from the dispensing head, soak the faucets in cleaning solution for 10-15 minutes. Use a faucet brush inside the spout, then brush out from the back of the faucet (there is no need to remove the handle assembly.) Rinse with clean water and install back on the dispensing head.

Troubleshooting

Symptom	Possible Cause (see back for Parts diagram)	Possible Solution
Faucet drips or leaks from the spout	<ul style="list-style-type: none"> • Front Seat (7) is damaged or worn • Handle Lever (5A or 5B) is damaged • Bearing Cup (4) is not installed properly • Bonnet is loose 	<ul style="list-style-type: none"> • Replace Front Seat • Replace Handle Lever • Reinstall Bearing Cup • Tighten Bonnet
Faucet leaks from flow control lever	<ul style="list-style-type: none"> • Worn or damaged seal • Loose cap 	<ul style="list-style-type: none"> • Replace seals • Tighten cap
Faucet leaks from bonnet	<ul style="list-style-type: none"> • O-ring (6) is not installed properly in O-ring groove • O-ring (6) may be damaged 	<ul style="list-style-type: none"> • Replace O-ring
Flow control handle lever does not change flow rate	<ul style="list-style-type: none"> • Handle lever orientation incorrect 	<ul style="list-style-type: none"> • Install faucet onto shank with handle lever orientated to front of faucet (towards spout)
Faucet leaks at the shank	<ul style="list-style-type: none"> • Faucet not connected tightly • Bad Coupling Gasket (8) 	<ul style="list-style-type: none"> • Tighten Coupling Nut • Replace Coupling Gasket
Beer pours in a semi-circular shape	<ul style="list-style-type: none"> • CO2 may be low or turned off 	<ul style="list-style-type: none"> • Check and adjust CO2 pressure
Faucet cannot be removed from shank	<ul style="list-style-type: none"> • May not have been removed recently 	<ul style="list-style-type: none"> • Pour hot water on the Coupling Nut on the shank to loosen it



FORWARD SEALING BEER FAUCETS

U.S. PATENT #8066257

Faucet Replacement Parts					
Item	630	680	650	690	Description
1	67829-1	67829-1	67829-1	67829-1	Handle Jacket, Chrome
	67829-1TF	67829-1TF	N/A	N/A	Handle Jacket, Tarnish Free
2	67820-1	67820-1	67820-1	67820-1	Compression Bonnet, Chrome
	67820-1TF	67820-1TF	N/A	N/A	Compression Bonnet, Tarnish Free
3	67828-1	67828-1	67828-1	67828-1	O-Ring, Compression
4	67819-2	67819-2	67819-2	67819-2	Bearing Cup
5A	68726-1	N/A	68626-1	N/A	Handle Lever
5B	N/A	68810	N/A	68810	Handle Lever, Push Back Creamer
6	67830-1	67830-1	67830-1	67830-1	O-Ring, Pivot Ball
7	67933-1	67933-1	67933-1	67933-1	O-Ring, Front Seat
8	308-3-2P	308-3-2P	308-3-2P	308-3-2P	Coupling Gasket
9	N/A	N/A	68206-1	68206-1	Flow Control: Compensator
10	N/A	N/A	67989SK	67989SK	Flow Control: Seal Kit
11	N/A	N/A	67989LK	67989LK	Flow Control: Lever & Seal Kit

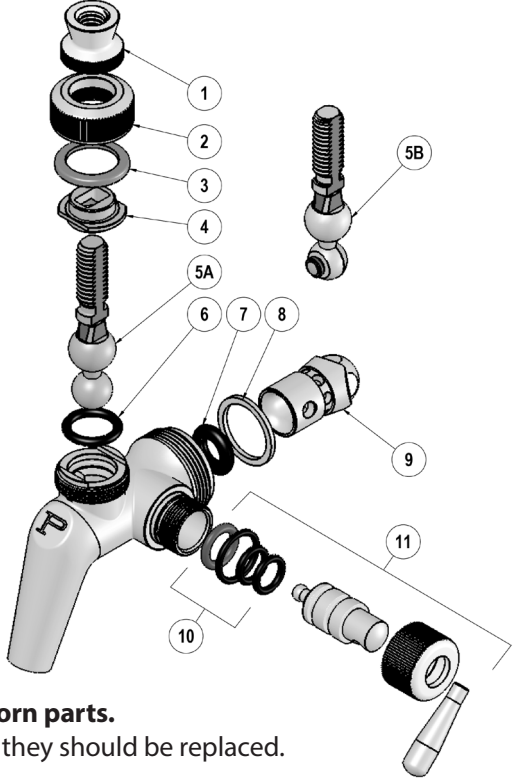

Follow these instructions if you need to take the faucet apart to replace worn parts.
Note: Anytime the Front Seat (I), O-ring (H) or Coupling Gasket(s) are removed, they should be replaced.
 Always use OEM replacement parts.

TO DISASSEMBLE:

1. If faucet is USED, soak faucet in warm cleaning solution for 1-2 minutes to free up bonnet and handle jacket. If the faucet is NEW, submerge the faucet in warm water for 5 seconds.
2. Unscrew and remove **Jacket (1)**.
3. Unscrew and remove **Compression Bonnet (2)**.
4. Remove **Coupling Gasket (8)** only if cut or worn.
5. To remove the **Handle Lever Assembly (5A or 5B)**, lift it upward and push back.
6. To remove **Front Seat (7)** use a small screwdriver from the bonnet end of the faucet.
7. To remove **O-ring (6)** use a small screwdriver from the bonnet end of the faucet.
8. Inspect O-rings for wear or damage and replace as necessary.
9. To remove flow control lever, unscrew cap and pull out.
10. Remove flow control compensator from rear of faucet.

TO ASSEMBLE:

1. Re-install **O-ring (6)** into O-ring groove from bonnet end (use a small blunt screwdriver).
2. Re-install front **Seat (7)** into O-ring groove (use a small blunt screwdriver). **Note:** Seat must move freely in seat groove.
3. Re-install **Handle Lever Assembly (5A or 5B)**.
4. Re-install **Bearing Cup (4)**.
5. Re-install **Bonnet Washer (3)** into **Compression Bonnet (2)**.
6. Re-install **Compression Bonnet (2)**. Tighten by hand only. Do not use any tool, as this can damage the faucet.
7. Re-install **Handle Jacket (1)**.
8. Re-install **Coupling Gasket (8)** if removed.
9. Install flow control compensator into rear of faucet and orientate so level engagement hole is facing lever insertion hole.
10. Install flow control lever, ensure pin on end of lever is aligned with compensator engagement hole and tighten cap.

Form No. 67952
Rev. 06.05.14