



ORION 2.0

PROIETTORI / HEADLAMPS

HYBRID & FULL LED





ORION 2.0 HYBRID

Proiettori / Headlamps

SPECIFICHE TECNICHE

Technical specifications

- Alimentazione: 12V o 24V
- Connettore: DEUTSCH 6 vie
- Lampada: H4 (12V 60-55W / 24V 70-75W)
- Inversione di polarità: protetto
- Load dump: protetto
- Surriscaldamento: protetto
- Temperatura colore: 6000 K
- Grado di protezione: IP6K9K
- Temperatura di funzionamento: - 40° C ÷ + 70° C
- Peso: 1,6 Kg
- Omologazione: ECE
- Compatibilità elettromagnetica (EMC): ECE R10 - CISPR 25 class 3

- Power supply: 12V or 24V
- Connector: DEUTSCH 6 ways
- Bulb: H4 (12V 60-55W / 24V 70-75W)
- Reverse polarity: protected
- Load dump: protected
- Overheat: protected
- Color temperature: 6000 K
- Sealing degree: IP6K9K
- Operating temperature: - 40° C ÷ + 70° C
- Weight: 1,6 Kg
- Homologation: ECE
- Electromagnetic compatibility (EMC): ECE R10 - CISPR 25 class 3



Vista laterale / Lateral view



Funzioni Functions		Potenza / Power	
		12V	24V
	Halogen	55W	70W
	Halogen	60W	75W
	LED	0,8W	1,3W
D.R.L.	LED	6,2W	6,4W
	LED	6,2W	7,2W

Vista posteriore / Rear view



DEUTSCH 6 vie / 6 ways:
Connettore / Connector
P/N COBO **3035543** (XE0806776)
Connettore controparte
Mating connector
P/N COBO **1005320** (XE0802582)

OPTIONAL KIT
Connettore controparte
Mating connector
P/N COBO **1028490** (27.0862.0000)



ORION 2.0 HYBRID

Fissaggio con snodo posteriore / *Rear articulated joint fixing*



	VOLT	P/N		Pkg Q.ty
		RH	LH	
RHD	12V	1078609 05.2082.0000	1078616 05.2083.0000	1
	24V	1078639 05.2082.0000	1078640 05.2083.0000	1
LHD	12V	1078625 05.2093.0000	1078626 05.2094.0000	1
	24V	1078676 05.2093.0000	1078685 05.2094.0000	1

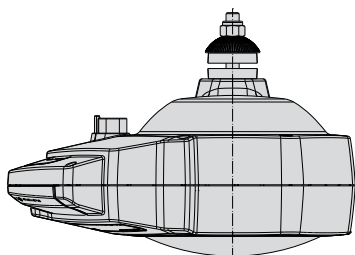
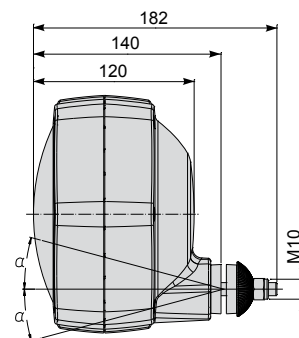
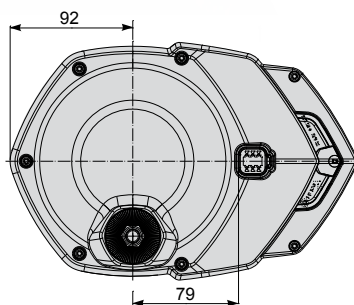
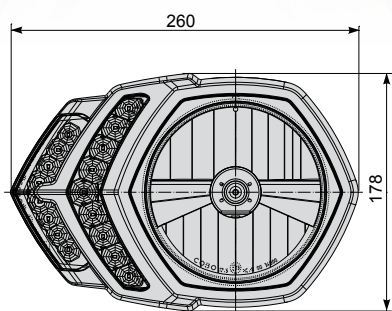

FORATURA DI APPLICAZIONE

Fixing hole

MONTAGGIO ORIZZONTALE <i>Horizontal Mounting</i>	
GRUPPO DX <i>RH Group</i>	GRUPPO SX <i>LH Group</i>

Spessore piastra <i>Plate thickness</i>	Foro piastra <i>Plate hole</i>	
	Ø 11	Ø 12
	Angolo di regolazione (α) <i>Angle of adjustment (α)</i>	
3 mm	± 15°	± 15°
4 mm	± 13°	± 15°
5 mm	± 10°	± 15°
6 mm	± 8°	± 15°

ORION 2.0 HYBRID

Fissaggio con snodo inferiore / Lower articulated joint fixing



	VOLT	P/N		Pkg Q.ty
		RH	LH	
RHD	12V	1078620 05.2091.0000	1078623 05.2092.0000	1
	24V	1078641 05.2091.0000	1078642 05.2092.0000	1
LHD	12V	1078627 05.2095.0000	1078628 05.2096.0000	1
	24V	1078689 05.2095.0000	1078691 05.2096.0000	1

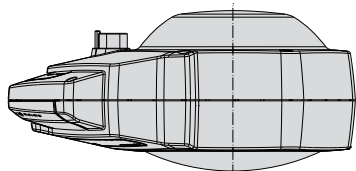
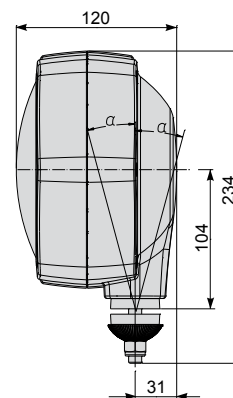
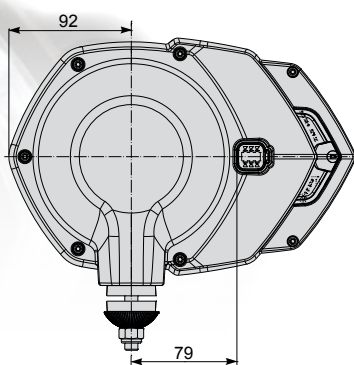
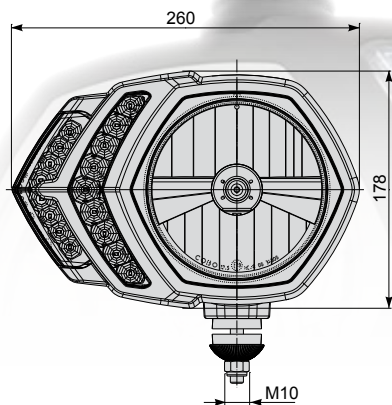

FORATURA DI APPLICAZIONE

Fixing hole

MONTAGGIO ORIZZONTALE Horizontal Mounting	
GRUPPO DX RH Group	GRUPPO SX LH Group

Spessore piastra Plate thickness	Foro piastra Plate hole	
	Ø 11	Ø 12
	Angolo di regolazione (α) Angle of adjustment (α)	
3 mm	± 15°	± 15°
4 mm	± 13°	± 15°
5 mm	± 10°	± 15°
6 mm	± 8°	± 15°



ORION 2.0 FULL LED

Proiettori / Headlamps

SPECIFICHE TECNICHE

Technical specifications





- Alimentazione: 9 - 32V
- Connettore: DEUTSCH 6 vie
- Inversione di polarità: protetto
- Load dump: protetto
- Surriscaldamento: protetto
- Temperatura colore: 6000 K
- Grado di protezione: IP6K9K
- Temperatura di funzionamento: - 40° C + + 85° C
- Peso: 2,8 Kg
- Omologazione: ECE
- Compatibilità elettromagnetica (EMC): ECE R10 - CISPR 25 class 3

- Power supply: 9 - 32V
- Connector: DEUTSCH 6 ways
- Reverse polarity: protected
- Load dump: protected
- Overheat: protected
- Color temperature: 6000 K
- Sealing degree: IP6K9K
- Operating temperature: - 40° C + + 85° C
- Weight: 2,8 Kg
- Homologation: ECE
- Electromagnetic compatibility (EMC): ECE R10 - CISPR 25 class 3



Vista laterale / Lateral view



Funzioni / Functions		Potenza / Power 9 - 32V
	LED	21,5W
	LED	13W
	LED	1,3W
D.R.L.	LED	6,4W
	LED	7,2W

Vista posteriore / Rear view



DEUTSCH 6 vie / 6 ways:
Connettore / Connector
P/N COBO 3035543 (XE0806776)
Connettore controparte
Mating connector
P/N COBO 1005320 (XE0802582)

OPTIONAL KIT
Connettore controparte
Mating connector
P/N COBO 1028490 (27.0862.0000)



ORION 2.0 FULL LED

Fissaggio con snodo posteriore / *Rear articulated joint fixing*



	VOLT	P/N		Pkg Q.ty
		RH	LH	
RHD	9 - 32V	1080920 05.2084.0000	1080921 05.2085.0000	1

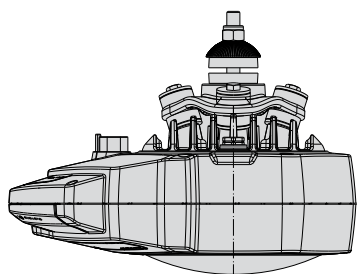
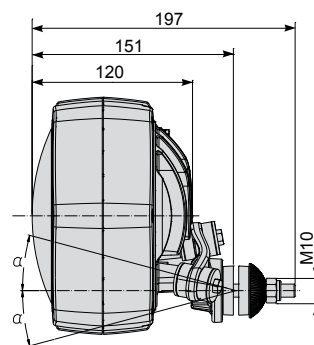
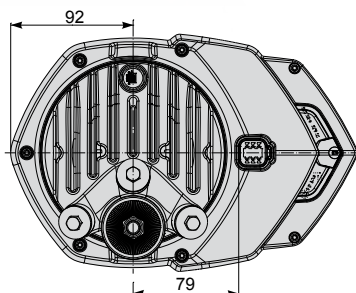
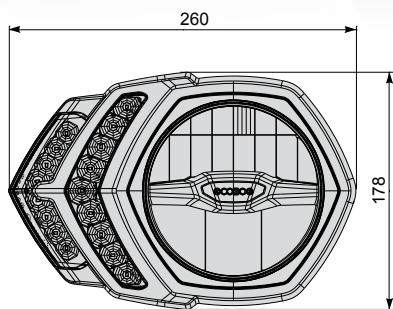

FORATURA DI APPLICAZIONE

Fixing hole

MONTAGGIO ORIZZONTALE <i>Horizontal Mounting</i>	
GRUPPO DX <i>RH Group</i>	GRUPPO SX <i>LH Group</i>

Spessore piastra <i>Plate thickness</i>	Foro piastra <i>Plate hole</i>	
	Ø 11	Ø 12
	Angolo di regolazione (α) <i>Angle of adjustment (α)</i>	
3 mm	± 15°	± 15°
4 mm	± 13°	± 15°
5 mm	± 10°	± 15°
6 mm	± 8°	± 15°

ORION 2.0 FULL LED

Fissaggio con snodo inferiore / Lower articulated joint fixing



	VOLT	P/N		Pkg Q.ty
		RH	LH	
RHD	9 - 32V	1080927 05.2120.0000	1080928 05.2121.0000	1

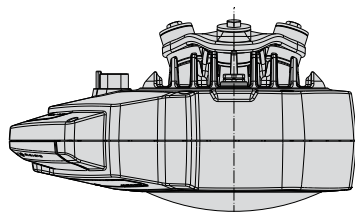
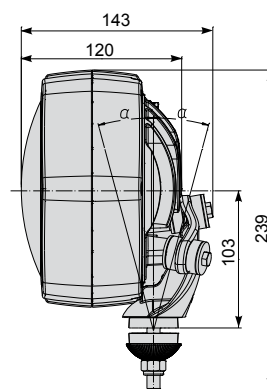
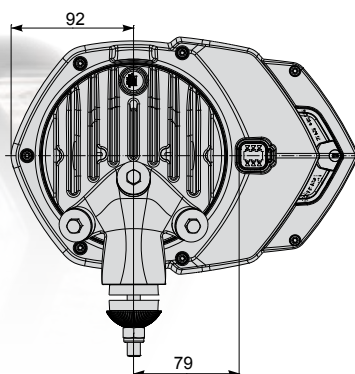
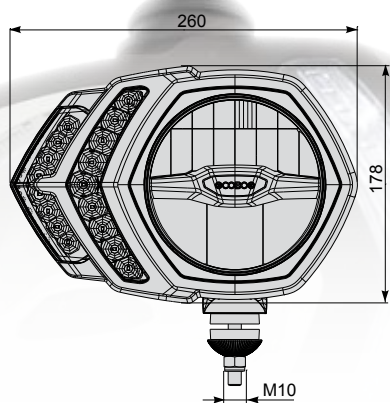

FORATURA DI APPLICAZIONE

Fixing hole

MONTAGGIO ORIZZONTALE Horizontal Mounting	
GRUPPO DX RH Group	GRUPPO SX LH Group

Spessore piastra Plate thickness	Foro piastra Plate hole	
	Ø 11	Ø 12
3 mm	± 15°	± 15°
4 mm	± 13°	± 15°
5 mm	± 10°	± 15°
6 mm	± 8°	± 15°



D.R.L. / Position / Direction Lamps LED

Modulo / Module

SPECIFICHE TECNICHE

Technical specifications

- | | |
|---|---|
| <ul style="list-style-type: none"> • Alimentazione:
9 - 32V
12V • Inversione di polarità: protetto • Load dump: protetto • Surriscaldamento: protetto • Temperatura colore: 6000 K • Grado di protezione: IP6K9K • Temperatura di funzionamento: - 40° C + + 85° C • Peso: 260 g • Omologazione: ECE • Compatibilità elettromagnetica (EMC): ECE R10 - CISPR 25 class 3 | <ul style="list-style-type: none"> • Power supply:
9 - 32V
12V • Reverse polarity: protected • Load dump: protected • Overheat: protected • Color temperature: 6000 K • Sealing degree: IP6K9K • Operating temperature: - 40° C + + 85° C • Weight: 260 g • Homologation: ECE • Electromagnetic compatibility (EMC): ECE R10 - CISPR 25 class 3 |
|---|---|

P/N
2124349
05.2082.2000

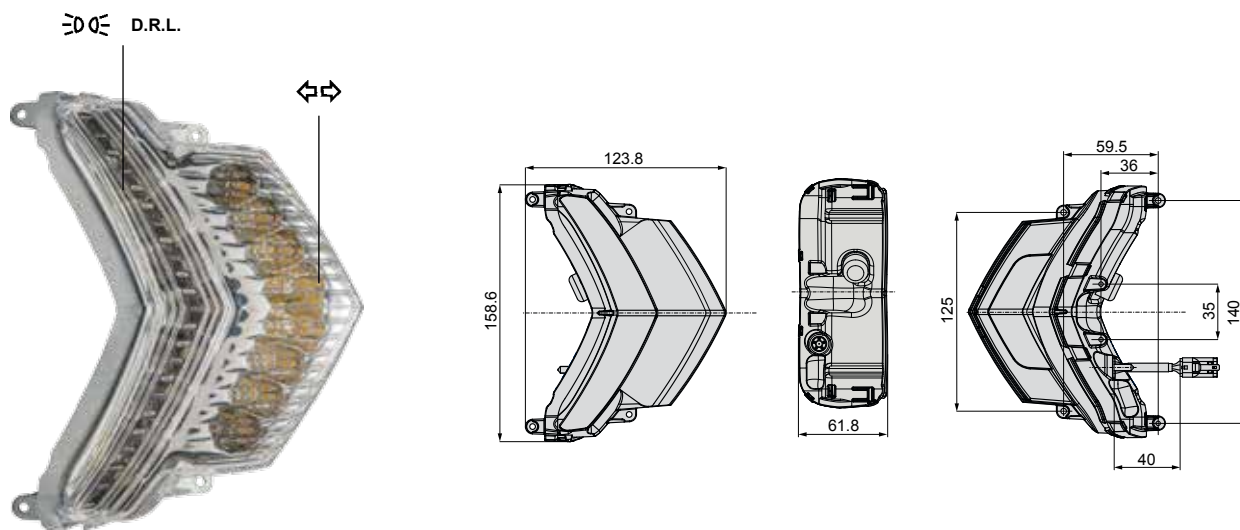

CONCEPT APPLICATIONS



**coming soon
2018**

Ø 80 D.R.L. / FOG LIGHT FULL LED

Fissaggio con staffa di regolazione / *Adjustment bracket fixing*
Fissaggio con staffa 90° / *90° bracket fixing*

- Power supply: 24V
- Electromagnetic compatibility (EMC):
Military Standard MIL – STD – 461F / DEFSTAN 59-411

- Power supply: 12V or 24V
- Electromagnetic compatibility (EMC): ECE R10



Ø 136 HEADLAMP HALOGEN

Fissaggio con snodo inferiore
Lower joint fixing



Ø 136 HEADLAMP FULL LED

Fissaggio con staffa di regolazione
Adjustment bracket fixing



Ø 136 HEADLAMP *FULL LED*

Fissaggio con snodo posteriore / *Rear joint fixing*

Vista posteriore / *Rear view*



Fissaggio con snodo inferiore / *Lower joint fixing*

Vista posteriore / *Rear view*





Legenda simboli *Icons legend*

LH Sinistro
Left

RH Destro
Right

 Anabbaglianti
Low beams

 Abbaglianti
High beams

 Luci di posizione
Position lights

D.R.L. Daytime Running Lamp

 Direzione
Turn signal

RHD Circolazione destra
Right Hand Driving

LHD Circolazione sinistra
Left Hand Driving

GERMANY



Eurotec-Ring 15
D-47445 Moers (Düsseldorf - Wesel)
Vestfalia
Phone: +49 (0) 2841 88238-0
Fax: +49 (0) 2841 88238-23
E-mail: info@cobogroup.net
Web Site: www.cobo-deutschland.com

FRANCE



2 Avenue de l'Europe Zone Coriolis
71210 Écuisses (Saône-et-Loire)
Bourgogne
Phone: +33 (0) 3 857 30560
Fax: +33 (0) 3 857 85606
E-mail: info@cobogroup.net
Web Site: www.cobofrance.com

NORTH AMERICA



304 W. Division St.
52655 West Burlington, Iowa - USA
Phone: +1 319 754 5585
Fax: +1 319 754 8724
E-mail: info@cobogroup.net
Web Site: www.cobointernational.com

LATIN AMERICA



Rua Dona Francisca, 8300, Bloco 9, Módulo C
89219-600 Zona Industrial Norte
Joinville - Santa Catarina (Brasil)
Phone: +55 47 3305 0095
E-mail: info@cobogroup.net

SOUTH-EAST ASIA



Unit 622 One Island South
2 Heung Yip Road
Wong Chuk Hang - Hong Kong
Phone: +852 3590 3588
Fax: +852 3590 3566
E-mail: info@cobogroup.net
Web Site: www.cobogroup.net

CHINA



Block D Guangying Technology Innovation Park
226 Qiaotou Street, Beishan, Haizhu District
Guangzhou, P.R.China
Phone: +86 20 8922 5611 / +86 20 8922 5633
Fax: +86 20 8922 5635
E-mail: info@cobogroup.net
Web Site: www.cobochina.cn

OCEANIA



4/12 Maiella St
4207 Stapylton (Brisbane)
Queensland - Australia
Phone: +61 (0) 7 3807 4866
Fax: +61 (0) 7 3807 6780
E-mail: info@cobogroup.net
Web Site: www.cobo.com.au



C.O.B.O. SpA

Via Tito Speri, 10
25024 Leno (Brescia) ITALY
Phone +39 030 90451
Fax +39 030 9045330



info@cobogroup.net | www.cobogroup.net

Le informazioni contenute nella presente informativa hanno scopo puramente indicativo.
L'Azienda si riserva senza preavviso il diritto di apportare qualsiasi modifica tecnica del prodotto.
The information published in this catalogue is purely indicative. The Company reserves the right to introduce all technological changes of the present product at any time and without prior notice.