

Elastomer Jaw Couplings



RINGFEDER® GWE



RINGFEDER® TNM



RINGFEDER® TNS



RINGFEDER® TNB

EN 04.2020

Product Paper & Tech Paper



Welcome



Machine Building



Aerospace



Process



Movement



Energy



Extraction



Your system supplier for every aspect of power transmission

We say what we mean and mean what we say.

We see things from our customers' perspective.

We are considerate of our employees and their families as well as of our environment and society.



RINGFEDER POWER TRANSMISSION is the global market leader in the niche markets of drive technology and is well regarded for its customer-specific, application-oriented solutions that ensure excellent and failure-free operation for its clients. We offer locking devices, damping technology and couplings for OEMs but also for the final customer under our strong brand name RINGFEDER®.

We do not only provide competent advice to our customers on the basis of our 90 years of experience but also develop innovative ideas in cooperation with them. This is part of our aspiration to be a **Partner for Performance**.

Around the power transmission we promise

- Excellent know-how for our challenging customers
- Best cost-benefit ratio
- Short reaction times and a high product availability





Know-how

Over 90 years of expertise.

On-site worldwide

We are there for you. Anytime, anywhere.

Your expert partner

From development to the finished product.

Customer

Value

Online calculation program

Always find the right solution.

Your projects are our drive

Know-how: Over 90 years of expertise.

Rely on decades of engineering expertise from the inventor of the friction spring. As an expert in drive and damping technology, we are your reliable partner wherever forces are at work. Be it the permanent transfer of very high torques due to non-positive or positive connections or the absorption and trapping of extreme energies to protect expensive constructions.

Your expert partner: From development to the finished product.

We accompany you through to the successful completion of your project. Beginning with the development phase of your project, we offer our know-how and professional solutions. By working together with global market leaders and as an international supplier of outstanding products and special solutions, we are a reliable partner for you.

Online calculation program: Always find the right solution.

In response to the complex requirements involved in the correct selection and design of the required products under practical conditions, we have developed our online calculation program. Engineers and experts are able to calculate transferable torques and other important values, taking into account various parameters. Visit our website www.ringfeder.com!

On-site worldwide: We are there for you. Anytime, anywhere.

With our locations in Germany, the Czech Republic, the USA, Brazil, China and India as well as a worldwide service and partner network, we are there for you around the clock. This ensures our support for the successful completion of your projects at any time.

RINGFEDER®

Elastomer Jaw Couplings

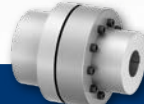
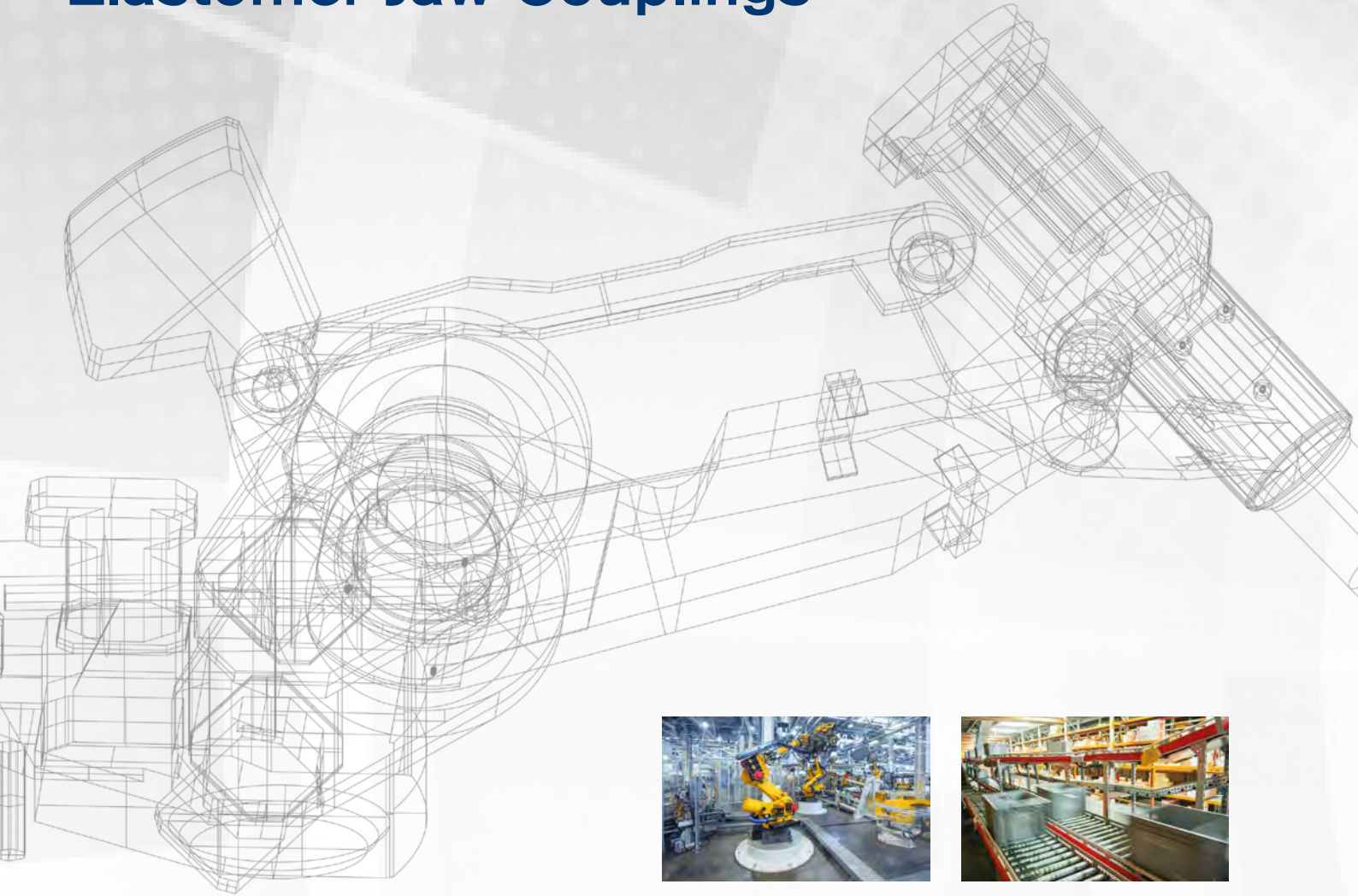

Elastomer Jaw Couplings	RINGFEDER® GWE	RINGFEDER® TNM	RINGFEDER® TNS	RINGFEDER® TNB
Torque	0,3 – 1920 Nm	13 – 41000 Nm	4 – 13350 Nm	1000 – 260000 Nm
Torsionally flexible	●	●	●	●
Puncture-proof	●	●	●	●
Backlash-free	●			
Compensation of misalignments (axial, radial, angular)	●	●	●	●
Axially pluggable	●	●	●	●
Low-maintenance	●			
Temperature range	-30 °C to +100 °C	-30 °C to +100 °C	-30 °C to +100 °C	-30 °C to +100 °C

Introduction

The rotationally resilient couplings of the RINGFEDER® series GWE, TNM, TNS und TNB are puncture-proof and flexible in all directions and therefore compensate for angular, parallel and axial shaft misalignments of the connected machines. Misalignments can be caused for example by inaccurate assembly, heat movements or settling phenomena.

Avoiding torsional vibration

By virtue of the rotational resilience of the coupling, dangerous torsional vibrations from the operational range of plant machinery can be transfer to rotational speed ranges in which no negative effects are to be expected. Material damping of the elastic parts contributes to limiting the resonance peaks when passing risky revolution ranges and thus offers the protection of coupled machines from damage.

The damping of the couplings also alleviates torque shocks and has a calming effect on the activated oscillatory system. The transmission of structure-bound noise is reduced.

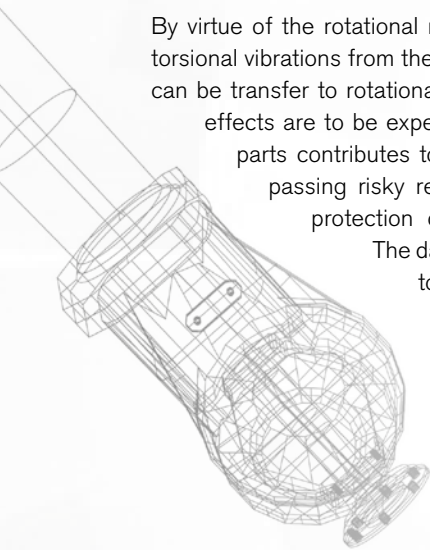

Environmental conditions

The employed elastomer materials operate reliably in ambient temperature ranges of -30 °C to +100 °C. Materials are available for higher and lower temperatures on request. The influence of the temperature on the coupling size selection is explained in more detail in the below-mentioned design directives.

The coupling should only be operated in normal industrial air. Aggressive media may attack the coupling components, bolts and elastic elements and therefore present a danger to the operational safety of the coupling.



**Maximum Safety in
Explosion-Endangered
Areas**

RINGFEDER® Elastomer Jaw Couplings can of course be delivered in compliance with ATEX according to Product Directive 2014/34/EU and DIN EN ISO 80079-36:2016 if required.



Elastomer Jaw Couplings	RINGFEDER® GWE	RINGFEDER® TNM*	RINGFEDER® TNS	RINGFEDER® TNB
Elastic parts	Spider	Intermediate rings	Intermediate rings	Buffer
Material	<p>Polyurethan (blue) Hardness: 80 SH A</p> <p>Polyurethan (yellow) Hardness: 92 SH A</p> <p>Polyurethan (red) Hardness: 95/98 SH A</p> <p>Hytrel (green) Hardness: 64 SH D-H</p> <p>Polyurethan (green) Hardness: 64 SH D</p>	<p>Perbunan (Pb72) (black) Basic material: NB Nitrile butadiene rubber Hardness: 72 Shore A</p> <p>Perbunan (Pb82) (black) Basic material: NB Nitrile butadiene rubber Hardness: 82 Shore A</p>	<p>Perbunan (Pb72) Basic material: NB Nitrile butadiene rubber Hardness: 72 Shore A</p> <p>Perbunan (Pb82) Basic material: NB Nitrile butadiene rubber Hardness: 82 Shore A</p> <p>Vulkollan VkR (rot) Casting polyurethane Hardness: 93 Shore A</p> <p>Vulkollan Vk60D (white) Casting polyurethane Hardness: 60 Shore D</p>	<p>Perbunan (Pb82) Basic material: NB Nitrile butadiene rubber Hardness: 82 Shore A</p> <p>Vulkollan VkR (red) Casting polyurethane Hardness: 93 Shore A</p> <p>Vulkollan VkW (white) Casting polyurethane Hardness: 96 Shore A</p>

Disclaimer of liability

All technical details and notes are non-binding and cannot be used as a basis for legal claims. The user is obligated to determine whether the represented products meet his requirements.

We reserve the right carry out modifications at any time in the interests of technical progress.



Drive side	Min. load factor S_A
E-Motor, turbine	1
Hydraulic motor	1,1
Combustion machine 4 and more cylinders, U-degrees $\leq 1:100$	1,2 (TVA)*
Combustion machine 1 to 3 cylinders, U-degree $> 1:100$	1,4 (TVA)*

S_A = Load factor of drive side: * We recommend for drivers with combustion machines to examine by a „TVA“ - torsional vibration calculation which coupling is suitable for the application.

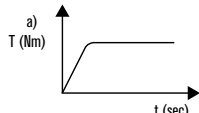
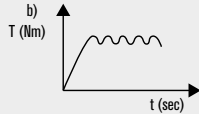
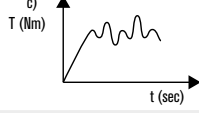
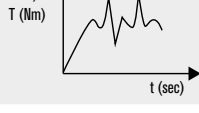
Torque characteristics at operating point on outside	Torque characteristics	Minimum load factor S_L
Constant, uniform without torque variation	a) 	1
Uniform with little variations, slight shocks	b) 	1,25
Non-uniform, also API-671, API-610 moderate shocks	c) 	1,5
Non-uniform, fluctuant, heavy shocks	d) 	1,75
Other torque characteristics		Own specification/ personal vibration calculation

S_L = Load factor of output side

Ambient temperature range [°C]	Temperature factor S_{θ} for elastic parts		
	RINGFEDER® GWE PUR, Hytel ¹⁾	RINGFEDER® TNM, TNS, TNB VkR, VkW, Vk60D	
			Pb72, Pb82 (NBR)
-30 < ϑ < +30	1	1	1
+30 < ϑ < +40	1,2	1,2	1
+40 < ϑ < +60	1,4	1,4	1
+60 < ϑ < +80	1,8	1,8	1,2
+80 < ϑ < +100	2	-	1,3
+100 < ϑ < +120	2,4	-	-

S_{θ} = Temperature factor depending on elastic materials. The elastic material may not be used in temperature ranges marked with a dash (-).

¹⁾ The maximum permissible ambient temperature in the chapter 'Technical description (Jaw Couplings RINGFEDER® GWE)' must be strictly observed.

Dimensioning of coupling

The dimensioning of the elastic RINGFEDER® couplings is based on the nominal torque T_N and maximum impact torque T_{max} of the machines.

Equation 1)

$$T_N = 9550 \cdot P_N / n_N$$

T_N	= Nominal torque of machine	[Nm]
P_N	= Machine power	[kW]
n_N	= Operating speed	[min ⁻¹]

The following equation applies when subjected to the nominal torque:

Equation 2)

$$T_{KN} > T_N \cdot S_{\vartheta} \cdot S_f$$

T_{KN}	= Nominal torque of coupling	[Nm]	acc. to Paper data
T_N	= Nominal torque of machine	[Nm]	acc. to equation 1)
S_{ϑ}	= Temperature factor	[-]	acc. to table
S_f	= Service factor	[-]	$S_A \cdot S_L$
S_A	= Load factor of drive side		
S_L	= Load factor of output side		

Verifying the maximum torque of the coupling

The following equation applies for transient impact torques, which occur e.g. by starting an electric motor

Equation 3)

$$T_{Kmax} > T_{max} \cdot S_{\vartheta} \cdot S_z$$

T_{Kmax}	= Maximum torque of the coupling	[Nm]	acc. to Paper data
T_{max}	= Maximum impact torque of machine *	[Nm]	

* e.g. when starting an electric motor: $T_{max} = T_{Kipp}$
 T_{Kipp} = Tipping torque by starting with directly engaged asynchronous motor
 e.g. $T_{Kipp} \sim 2,5 \cdot T$; observe details of motor producer

Start-ups per hour [1/h]	Start-up factor S_z
< 120	1
120 - 240	1,3
>240	On request

S_z = Start-up factor

Check selected coupling size

■ Check whether the **hub bore** is able to accommodate the shaft diameters. The values of the maximum finish bores stated in the tables are applicable for keyed connections according to DIN 6885/1 and must not be exceeded.

■ Check the power transmission capability of the **shaft-hub-connection**. The nominal torques stated in the tables will be reliably transmitted by the couplings. The introduction of the torque into the coupling hub has to be verified by the user of the coupling according to recognized rules of technology. If necessary, the second key is to be offset by 180°.

■ Please take into account the **maximum permissible speed** of the coupling. For coupling versions to bridge large separations between shafts, for example in RINGFEDER® GWE Z5104.1 and GWE Z5106.1 the critical bending speed must be tested or we must be commissioned with carrying out this test.

■ Check whether **balancing** is necessary. We advise to balance the coupling parts or sub assemblies if the circumferential speed at the outer diameter exceeds 22 m/s. Balancing can only be performed on couplings with finish-bores. Unless otherwise specified, the half key convention applies so that the hubs are balanced in accordance with DIN ISO 21940-11 Quality 6.3 for 1500 1/min before grooving.

Dimensioning example



Example for dimensioning a coupling for a pump drive with electric motor type IEC 355.

Preselected type:
RINGFEDER® TNB BHDD*

Input power $P_N =$	355 kW	
Operating speed $n_N =$	1480 min ⁻¹	
Nominal torque $T_N =$	$9550 \cdot P_N / n = 9550 \cdot 355 / 1480 = 2291 \text{ Nm}$	acc. to equation 1)
Ambient temperature $\vartheta =$	65 °C	
→ Temperature factor $S_\vartheta =$	1,8	für VkR
Load factor		
Drive motor	Directly engaged asynchronous motor (Δ-connection)	
→ Load factor of drive side $S_A =$	1	
Working machine	Centrifugal pump	Torque characteristics uniform with little variations
→ Load factor of output side $S_L =$	1,25	
Required nominal torque of the coupling $T_{KN} >$	$T_N \cdot S_\vartheta \cdot S_f = 2291 \text{ Nm} \cdot 1,8 \cdot 1,25 = 5155 \text{ Nm}$	acc. to equation 2)

Following the catalogue data the coupling is selected with a coupling size of BHDD 300 with intermediate ring VkR and a nominal coupling torque of 6000 Nm. The dimension of coupling RINGFEDER® BHDD 300 is OK for the performance data.

The operating speed of 1480 rpm results in a circumferential speed of 23.2 m/s. Therefore it is recommended to balance the coupling parts. If the shaft-hub connections are dimensioned sufficiently, this coupling can be used.

Verifying the maximum torque of the coupling

Maximum torque $T_{max} = T_{max} = T_{Kipp} =$ Tipping torque when starting with directly engaged asynchronous motors	$2,5 \cdot T_N = 2,5 \cdot 2291 \text{ Nm} = 5727,5 \text{ Nm}$	
Ambient temperature $\vartheta =$	65 °C	
→ Temperature factor $S_\vartheta =$	1,8	für VkR
Starts per hour	6	
→ Start-up factor $S_Z =$	1	für VkR
Required maximum torque of the coupling $T_{Kmax} >$	$T_{max} \cdot S_\vartheta \cdot S_Z = 5727,5 \text{ Nm} \cdot 1,8 \cdot 1 = 10310 \text{ Nm}$	acc. to equation 3)

Verifying the dimensioning result

Value	System data	Coupling data TNB BHDD 300 VkR
Nominal torque	5155 Nm (excl. safety factor)	6000 Nm
Maximum torque	10310 Nm (excl. safety factor)	17500 Nm
Speed	1480 min ⁻¹	max. 2500 min ⁻¹
Shaft diameter motor	95 mm	max. 120 mm
Shaft diameter pump	85 mm	max. 120 mm

* **Note:** The exemplary procedure for coupling design shown applies to all Elastomer Jaw Couplings of the RINGFEDER® GWE, TNM, TNS and TNB series.

Arrangement of the coupling parts

The arrangement of the coupling hubs on the shaft ends that are to be connected is free in principle. For couplings with attachment parts such as brake discs and drums these should be attached to the drive side that is to be locked. The hubs must be placed flush with the shaft end in order to make the shaft-hub connection stable.

Finished bore

The given values for the maximum finished bore may not be exceeded. A press fit or slightly tight fit are recommended in order to achieve good concentricity for the couplings in series TNM, TNS and TNB. For the GWE series please select a slight clearance fit or a press fit. Where there is no specification the finished bore is executed with a tolerance of H7.

Fastening on a shaft

RINGFEDER® GWE couplings transmit the torque to the shaft by clamping or keyway in accordance with DIN 6885/1 depending on the design. The couplings RINGFEDER® TNM, TNS and TNB are executed as standard with keyways. An axial fastening should also be included, such as a set screw and spacer rings on longer shaft ends. The key must be axially fixed in the shaft.

Observe restoring forces

The coupling compensates the permissible misalignments with low restoring forces. Please observe the alignment values specified in the assembly and operation manual. If highly loaded bearings are involved, the additional loads resulting from the restoring forces should be taken into consideration. In such cases, please contact RINGFEDER POWER TRANSMISSION for more detailed information.

Shaft end bearings

The shaft ends to be coupled should be supported by bearings which are directly fitted in front and after the coupling.

Attention!

In the interest of further development, we reserve the right to make changes which serve technological progress. Carefully observe the actually instructions given in the relevant installation and operation manual, which can be downloaded from our webpage www.ringfeder.com.



Elastomer Jaw Couplings



Backlash-free Elastomer Jaw Couplings RINGFEDER® GWE

Backlash-free RINGFEDER® GWE jaw couplings are used in engineering where high positioning precision requires vibration damping in greatly accelerated processes and the use of plug-in coupling solutions is preferred.

Characteristics · Advantages

- Backlash-free, through pre-stressing
- Pluggable
- Vibration damping
- Torques from 0,5 – 650 Nm
- Compensation of radial, axial and angular misalignment
- Electrically isolating

Applications

- Encoder
- Precision drives
- Feed drives
- Grinding and milling spindles
- Machine tools
- Packing machines
- Robotics
- Transfer lines
- Multi-spindle heads
- Wood processing equipment
- Textile machinery
- Conveying equipment
- Linear motion
- Measuring equipment and control technology
- Test rigs

Technical description

Every hub on the RINGFEDER® GWE jaw coupling has concave jaws on its face. The function of the coupling to transmit torque and damp impact that occurs, as well as balancing out unavoidable misalignments, is enabled through the joining of two hubs and the filling of the created free space with an elastic sprocket. The GWE jaw couplings are backlash-free in order to also achieve a high level of positioning precision in reverse operation. The coupling is backlash-

free as a result of the pressure pre-tensioning of the individual buffers in the elastomer sprocket. The different Shore hardness levels, which correlate to the torsional stiffness, mean that it is possible to optimise the entire drive line from the point of view of rotary oscillation. Detailed information is included in the technical data for the sprockets.

Spider Hardness (Shore)	Colour	Material	Allowable temperature °C		Available for size	Typical applications; preferred characteristics
			Continous temperature	Max. temp. short term		
80 SH A	blue	Polyurethane	-50 to +80	-60 to +120	5-19	Drives in electronic measuring systems; backlash-free when pre-compressed
92 SH A	yellow	Polyurethane	-40 to +90	-50 to +120	5-55	Main spindle drives; backlash-free when pre-compressed
*95/98 SH A	red	Polyurethane	-30 to +90	-40 to +120	5-75	Positioning drives; backlash-free when pre-compressed
64 SH D-H	green	Hytrel	-50 to +120	-60 to +150	7-38	Machine tool spindles, control drives, lead units, planetary gearboxes; heavy loads, torsionally stiff, high ambient temperature, water proof
64 SH D	green	Polyurethane	-20 to +110	-30 to +120	42-75	

* From size 65 \geq 95 SH A

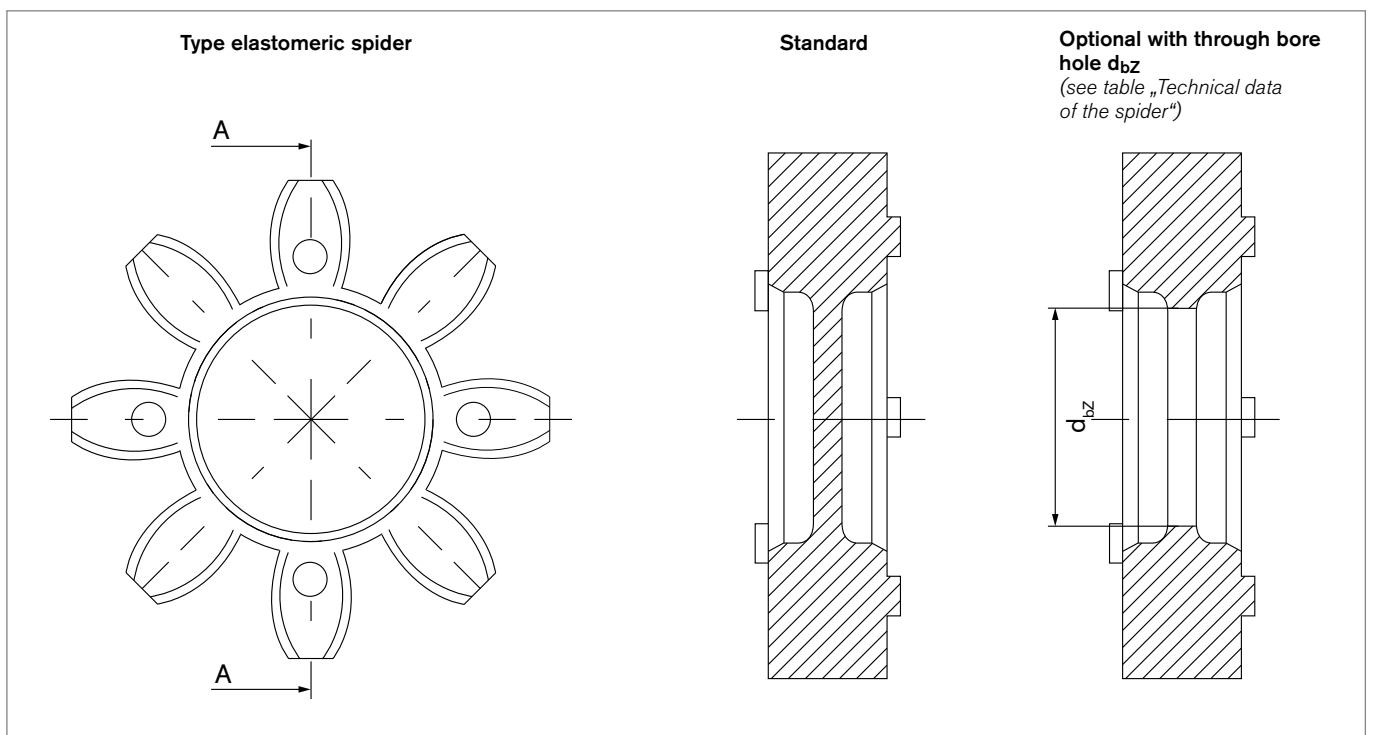

T_{KN} – Nominal torque of coupling (Nm):

Continuous torque which can be transmitted throughout the entire speed range, taking into consideration operational factors such as ambient temperature, operating, impact and start-up factors.

 T_{Kmax} – Maximum torque of coupling (Nm):

Torque which can be transmitted $>10^5$ time as a peak load or 5×10^4 times as an alternating load during the entire life of the coupling taking into consideration factors such as temperatures, torsional stiffness and shock loading.

The shaft-hub connection must be tested by the customer.

The stated static torsional stiffness **C_{Tstat}** and dynamic torsional stiffness **C_{Tdyn}** are valid for $0.5 T_{KN}$.

The axial misalignment **K_a** refers to the gap size shown in the data sheets.



Technical data of the spider

Size	SH	1/min					Nm		Nm/rad	Nm/rad	N/mm	optional d _{bZ} *	mm			Degree
		(5102)	(5113)	n _{max} (5103.1)	(5104)	(5112)	T _N	T _{max}	C _{Tstat}	C _{Tdyn}	C _r		ΔK _a	ΔK _r	ΔK _w	
5	80 SH A	47500	---	38000	---	---	0,3	0,6	3,2	10	82	---	+0,4/-0,2	0,12	1,1	
	92 SH A						0,5	1,0	5,2	16	154			0,06	1,0	
	98 SH A						0,9	1,7	8,3	25	296			0,04	0,9	
7	64 SH D-H	34000	---	27000	---	---	2,4	4,8	34	103	630	---	+0,6/-0,3	0,04	0,8	
	80 SH A						0,7	1,4	8,6	26	114			0,15	1,1	
	92 SH A						1,2	2,4	14,3	43	219			0,1	1,0	
	98 SH A						2,0	4,0	23	69	421			0,06	0,9	
9	64 SH D-H	24000	---	19000	---	---	6	12	74	224	769	6,5	+0,8/-0,4	0,05	0,8	
	80 SH A						1,8	3,6	17	52	125			0,19	1,1	
	92 SH A						3	6	31	95	262			0,13	1,0	
	98 SH A						5	10	51	155	518			0,08	0,9	
12	64 SH D-H	19000	15000	---	---	---	12	24	328	982	1198	7,5	+0,9/-0,4	0,05	0,8	
	80 SH A						3	6	84	252	274			0,2	1,1	
	92 SH A						5	10	160	482	470			0,14	1,0	
	98 SH A						9	18	241	718	846			0,08	0,9	
14	64 SH D-H	16000	13000	---	13000	25400	16	32	234	702	856	8,5	+1,0/-0,5	0,06	0,8	
	80 SH A						4	8	60	180	153			0,21	1,1	
	92 SH A						7,5	15	115	344	336			0,15	1,0	
	98 SH A						12,5	25	172	513	654			0,09	0,9	
19	64 SH D-H	12000	10000	---	10000	19000	21	42	1240	3720	2930	16	+1,2/-0,5	0,04	0,8	
	80 SH A						5	10	340	1030	582			0,15	1,1	
	92 SH A						10	20	570	1720	1120			0,1	1,0	
	98 SH A						17	34	860	2580	2010			0,06	0,9	
24	64 SH D-H	8500	7000	---	7000	13800	75	150	2980	8934	3696	24	+1,4/-0,5	0,07	0,8	
	92 SH A						35	70	1430	4296	1480			0,14	1,0	
	98 SH A						60	120	2060	6189	2560			0,1	0,9	
28	64 SH D-H	7300	6000	---	6000	11700	200	400	4350	13050	4348	27	+1,5/-0,7	0,08	0,8	
	92 SH A						95	190	2290	6876	1780			0,15	1,0	
	98 SH A						160	320	3440	10314	3200			0,11	0,9	
38	64 SH D-H	5900	5000	---	5000	9550	405	810	10540	31620	6474	35	+1,8/-0,7	0,09	0,8	
	92 SH A						190	380	4580	13752	2350			0,17	1,0	
	98 SH A						325	650	7160	21486	4400			0,12	0,9	
42	64 SH D	---	4000	---	4000	8050	560	1120	27580	71700	7270	42	+2,0/-1,0	0,1	0,8	
	92 SH A						265	530	6300	24300	2430			0,19	1,0	
	98 SH A						450	900	19200	48000	5930			0,14	0,9	
48	64 SH D	---	---	---	3600	7200	655	1310	36200	90500	8274	46	+2,1/-1,0	0,11	0,8	
	92 SH A						310	620	7850	18055	2580			0,23	1,0	
	98 SH A						525	1050	22370	55925	5930			0,16	0,9	
55	64 SH D	---	---	---	3150	---	825	1650	105730	130200	9248	---	+2,2/-1,0	0,12	0,8	
	92 SH A						410	820	15482	21375	2980			0,24	1,0	
	98 SH A						685	1370	42117	61550	6686			0,17	0,9	
65	64 SH D	---	---	---	2800	---	1175	2350	118510	189189	8870	---	+2,6/-1,0	0,13	0,8	
	98 SH A						940	1880	485200	71660	6418			0,18	0,9	
75	64 SH D	---	---	---	2350	---	2400	4800	182320	316377	11923	---	+3,0/-1,5	0,15	0,8	
	98 SH A						1920	3840	79150	150450	8650			0,21	0,9	

*d_{bZ} = Inner diameter elastomeric spider

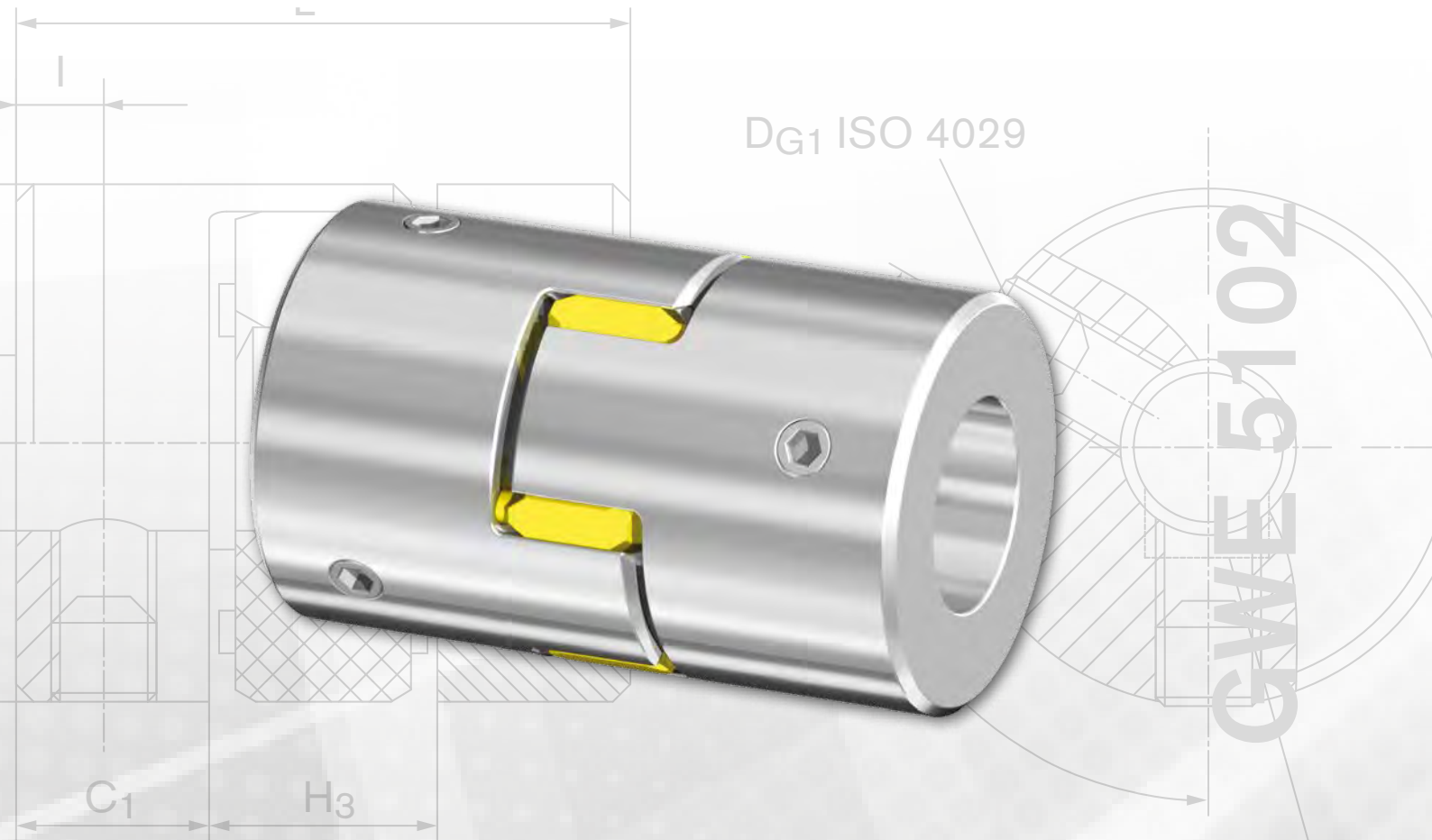

Further information on
RINGFEDER® GWE 5102
 on www.ringfeder.com

Keyway acc. DIN 6885-1 optionally

Miniature coupling with set screw hubs

RINGFEDER® GWE 5102 is a compact miniature coupling and the solution for low torque and narrow installation spaces. The coupling halves are fixed to the shaft with threaded pins rather than with clamping hubs. The shaft tolerance should lie within the fitting tolerance 'g6' to 'h7'. Two threaded pins offset by 120° produce the contact pressure between the coupling hub and the shaft that is necessary to transmit the torque.

The elastomer spiders are available in different Shore hardness levels. Whichever version you choose: **RINGFEDER® GWE 5102** miniature is electrically insulating and vibration damping.

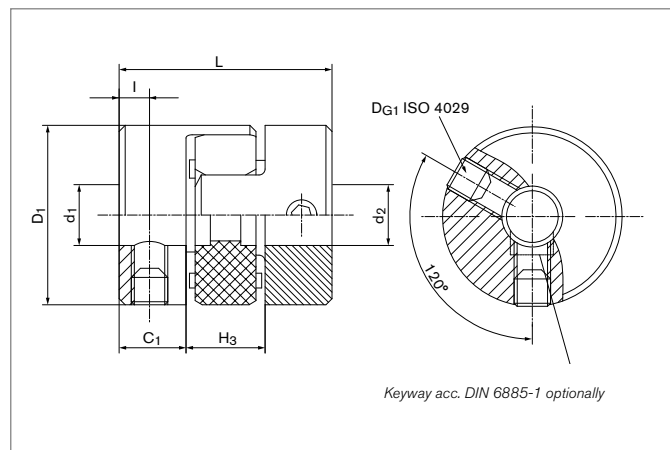

Characteristics

- Low mass through aluminium hubs
- Puncture-proof and electrically insulating
- Optimisation of the vibration damping through different elastomer spider hardness levels
- Length of threaded pin adapted to bore
- Standard with yellow elastomer spider (92 SH A)
- Coupling hubs optionally with keyways in accordance with DIN 6885-1

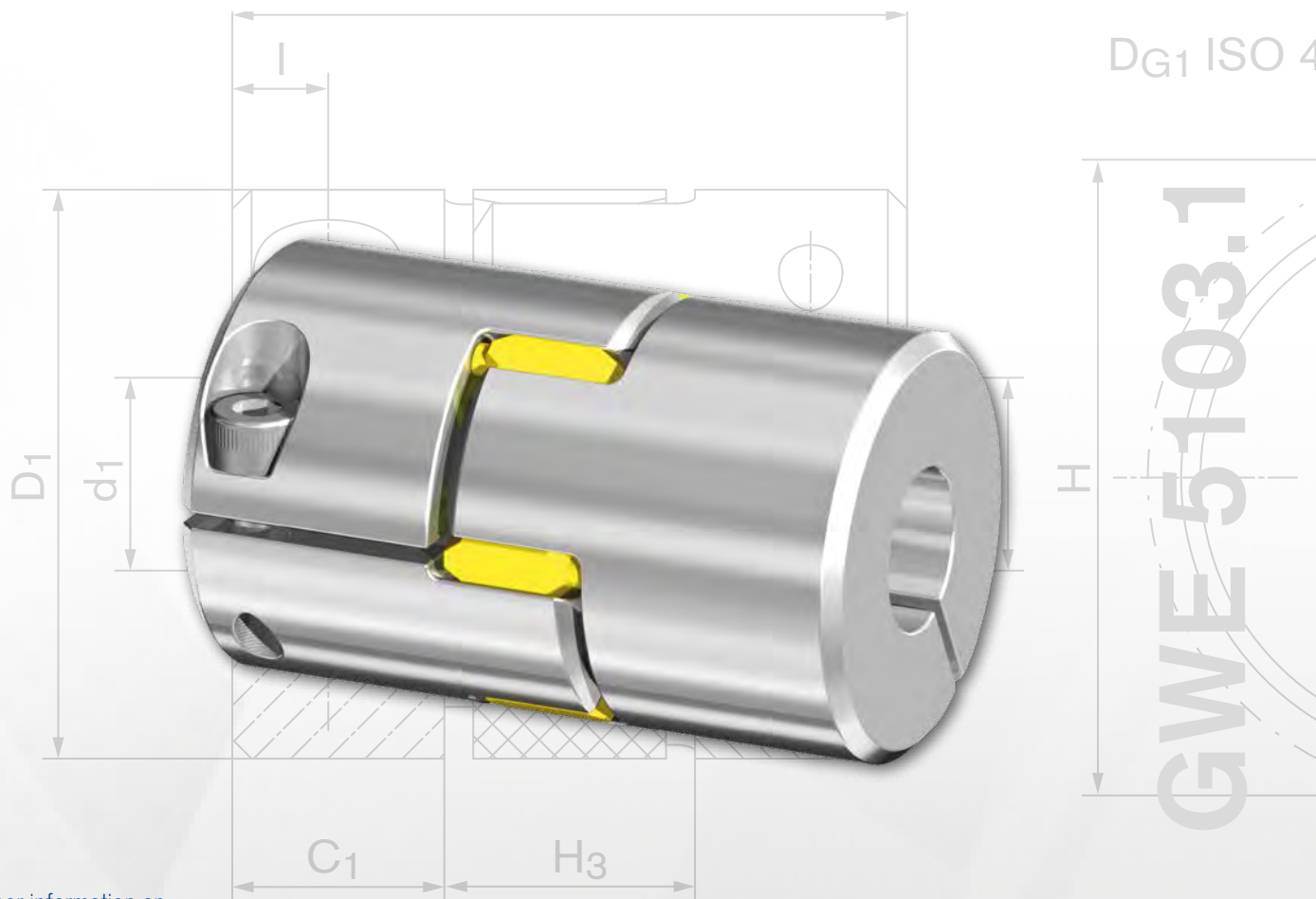

Further information on
RINGFEDER® GWE 5103.1
 on www.ringfeder.com

Miniature coupling with extended clamping hubs and single slit

The **RINGFEDER® GWE 5103.1** series of backlash-free jaw couplings excel with their compact design. It comprises two single-slit long coupling hubs with high concentricity and one elastomer spider that can be supplied in different Shore hardness levels. The shaft tolerance should lie within the fit tolerance 'g6' to 'h7'.

The elastomer spider produces a backlash-free, puncture-proof, damped and electrically insulated elastic jaw coupling.

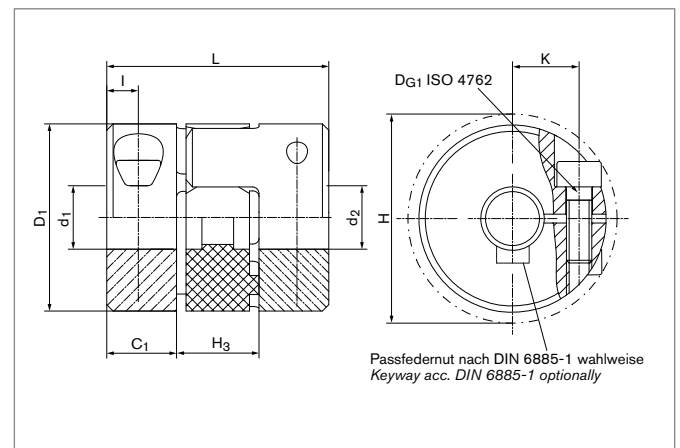

Characteristics

- Low mass through aluminium hubs
- Optimisation of the vibration damping through different elastomer spider hardness levels
- Standard with yellow elastomer spider (92 SH A)
- Puncture-proof and electrically insulating
- Maximum coverage of the shaft with long coupling hub.
- Coupling hubs optionally with keyways in accordance with DIN 6885-1

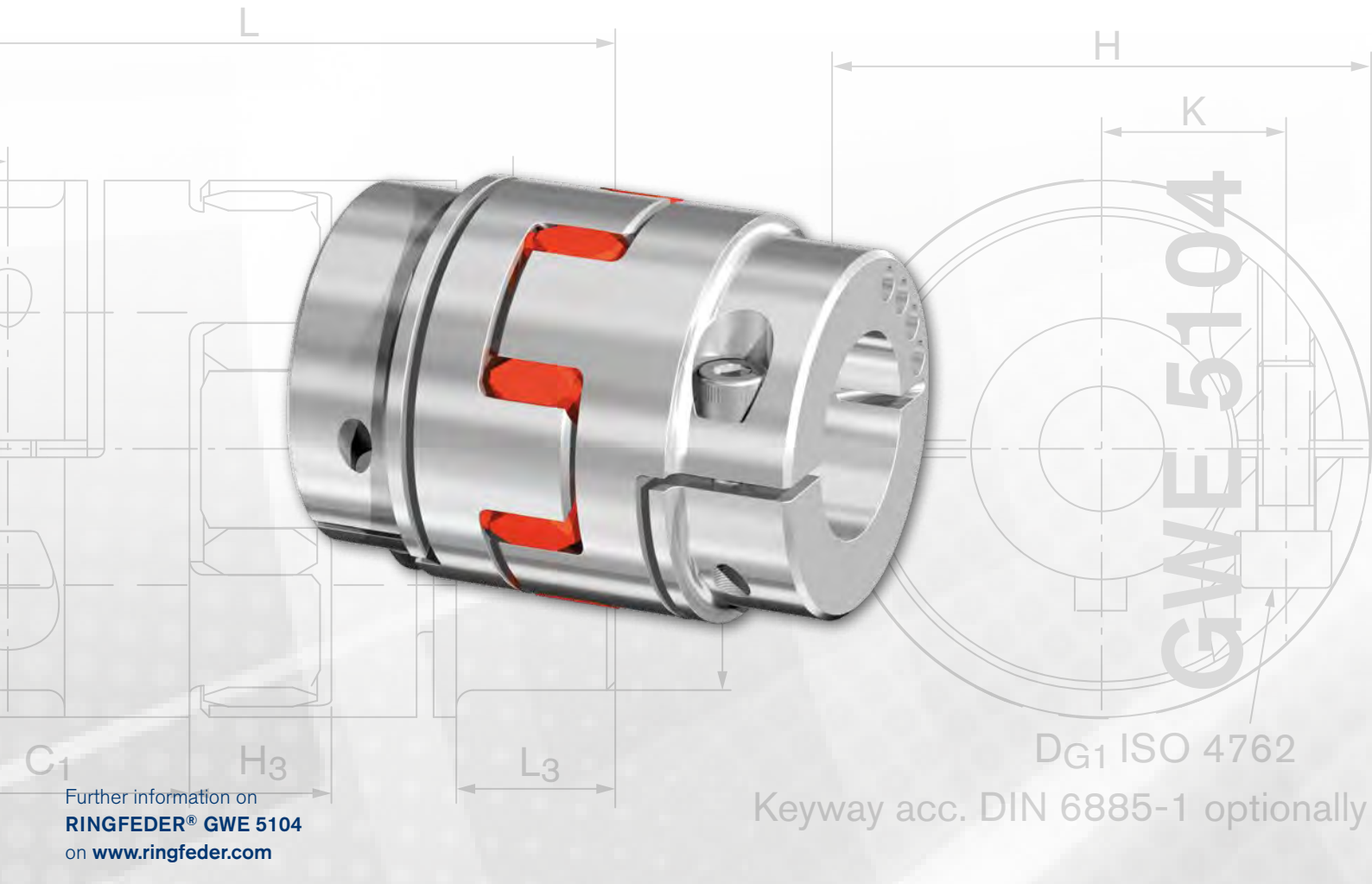

Servo-Insert coupling with clamping hubs and dual slits

Jaw couplings in the series **RINGFEDER® GWE 5104**, with clamp hubs and a high level of international standardisation. Up to size 19 it comprises two axially (single-)slit and from size 24 two axially and radially (double-)slit clamp hubs with high concentricity and an elastomer spider that can be supplied in different levels of Shore hardness. The shaft tolerance should lie within the fit tolerance 'g6' to 'h7'.

The coupling is available with elastomer spiders in different Shore hardness levels and impresses with its special damping properties.

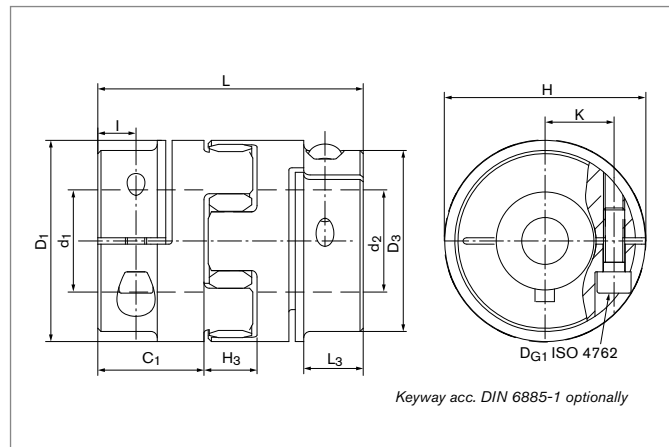

Characteristics

- Low mass through aluminium hubs
- Installation space in accordance with the known market standard
- Optimisation of the vibration damping through different elastomer spider hardness levels
- Puncture-proof and electrically insulating
- As standard with red elastomer spider. Up to size 55 in 98 Shore A and from size 65 in 95 Shore A
- Coupling hubs optionally with keyways in accordance with DIN 6885-1

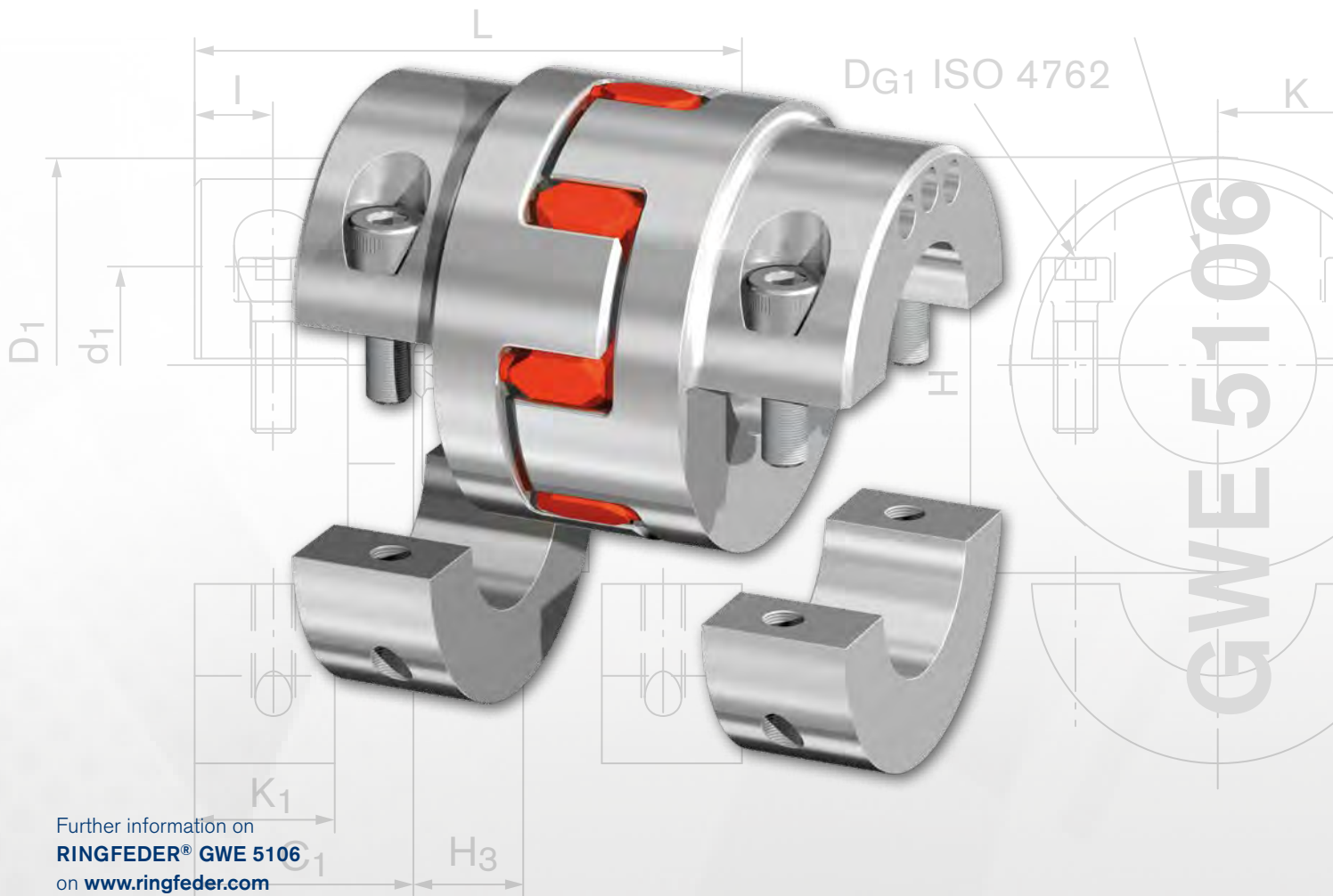

Servo-Insert coupling with clamping hubs in split hub design

The RINGFEDER® GWE 5106 combined the advantage of the RINGFEDER® GWE 5104 Servo-Insert Coupling with an easy installation. The clamping hubs in split hub design can be mounted lateral at the aligned shaft extensions. The shaft tolerance should lie within the fit tolerance 'g6' to 'h7'.

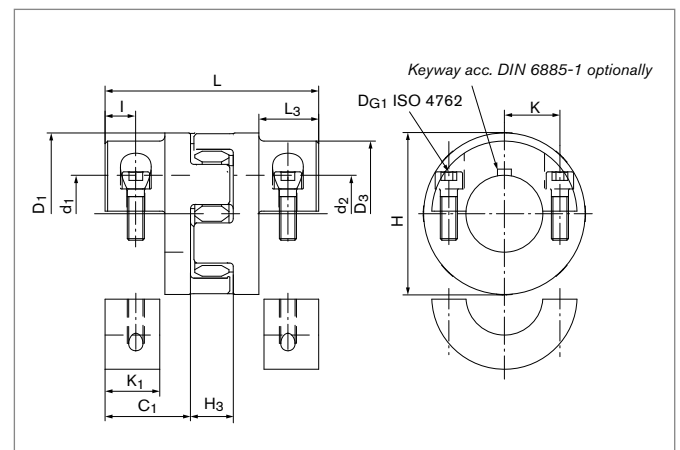

Characteristics

- Low mass through aluminium hubs
- Optimisation of the vibration damping through different elastomer spider hardness levels
- As standard with red elastomer spider. Up to size 55 in 98 Shore A and from size 65 in 95 Shore A
- Simple radial installation and removal without shifting the shafts
- Puncture-proof and electrically insulating
- Coupling hubs optionally with keyways in accordance with DIN 6885-1

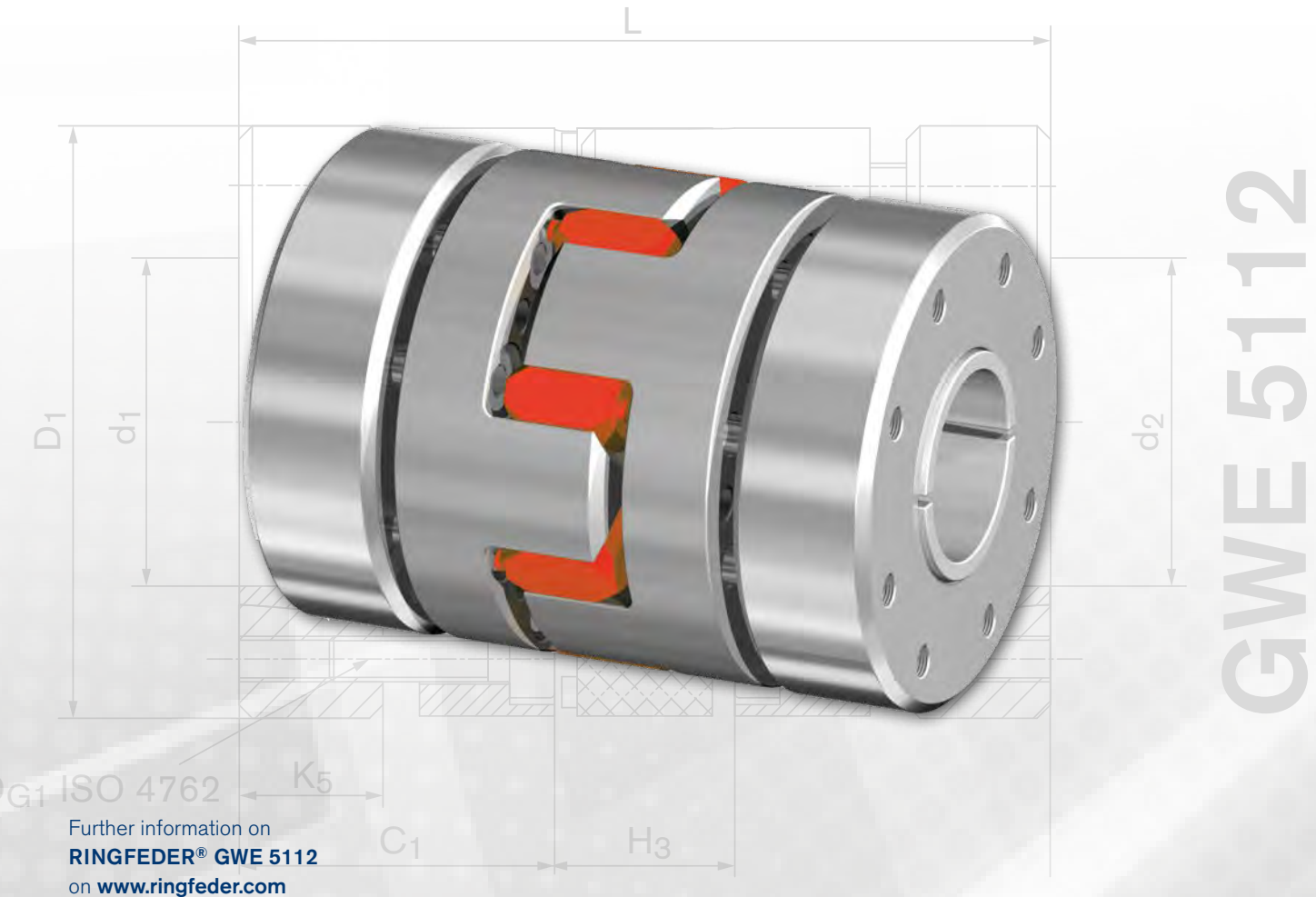

Servo-Insert coupling with outer cone

RINGFEDER® GWE 5112 is a backlash-free balance coupling with outer cone that is also suitable for the highest speeds. The best possible concentricity of the coupling parts that is necessary for this is made possible by the symmetrical structure and the precise manufacture.

High clamping force is produced on the shaft by tightening the easily accessible screw connection on the conical outer tensioning ring and this counters the impact of centrifugal force and has a positive effect on the torque transmission. The shaft tolerance should lie within the fit tolerance of 'g6' to 'h7'.

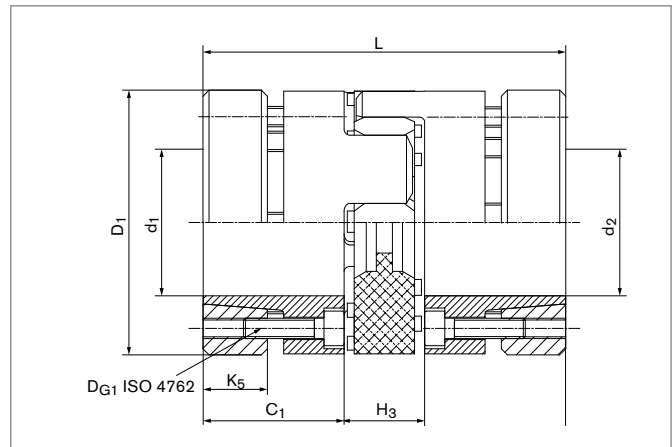

Characteristics

- Hubs up to size 38 made of aluminum, from size 42 made of steel
- Steel outer tensioning ring
- High concentricity of assembly friendly coupling
- Optimisation of the vibration damping through different elastomer spider hardness levels
- Standard with red spider 98 SH A
- Puncture-proof and electrically insulating



Further information on
RINGFEDER® GWE 5113
 on www.ringfeder.com

Servo-Insert coupling with clamping hubs, short length and single slit

The **RINGFEDER® GWE 5113** type of backlash-free jaw couplings is characterised among other things by its compact design with low moment of inertia. It comprises of two single-slit coupling hubs with high concentricity and one elastomer spider that can be supplied in different shore hardness levels. The shaft tolerance should lie within the fitting tolerance 'g6' to 'h7'.

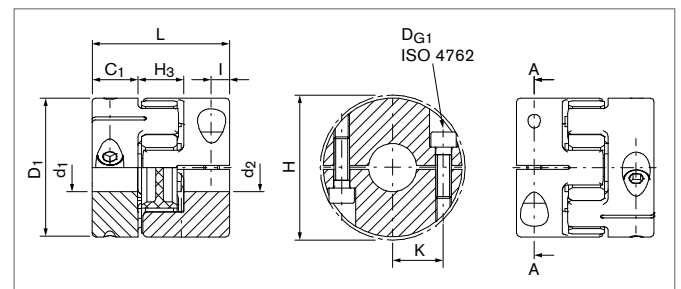

The elastomer spider creates a backlash-free, puncture-proof, damped and electrically insulated connection.

Characteristics

- Low mass through aluminium hubs
- Optimisation of the vibration damping through different elastomer spider hardness levels
- As standard in size 14 to 42 with red elastomer spider
- Puncture-proof and electrically insulating
- Coupling hubs optionally with keyways in accordance with DIN 6885-1
- Good concentric running properties and uniform power transmission due to jaw area without slit
- Equal weight distribution because of symmetrical screw position
- Compact design for application in limited installation space

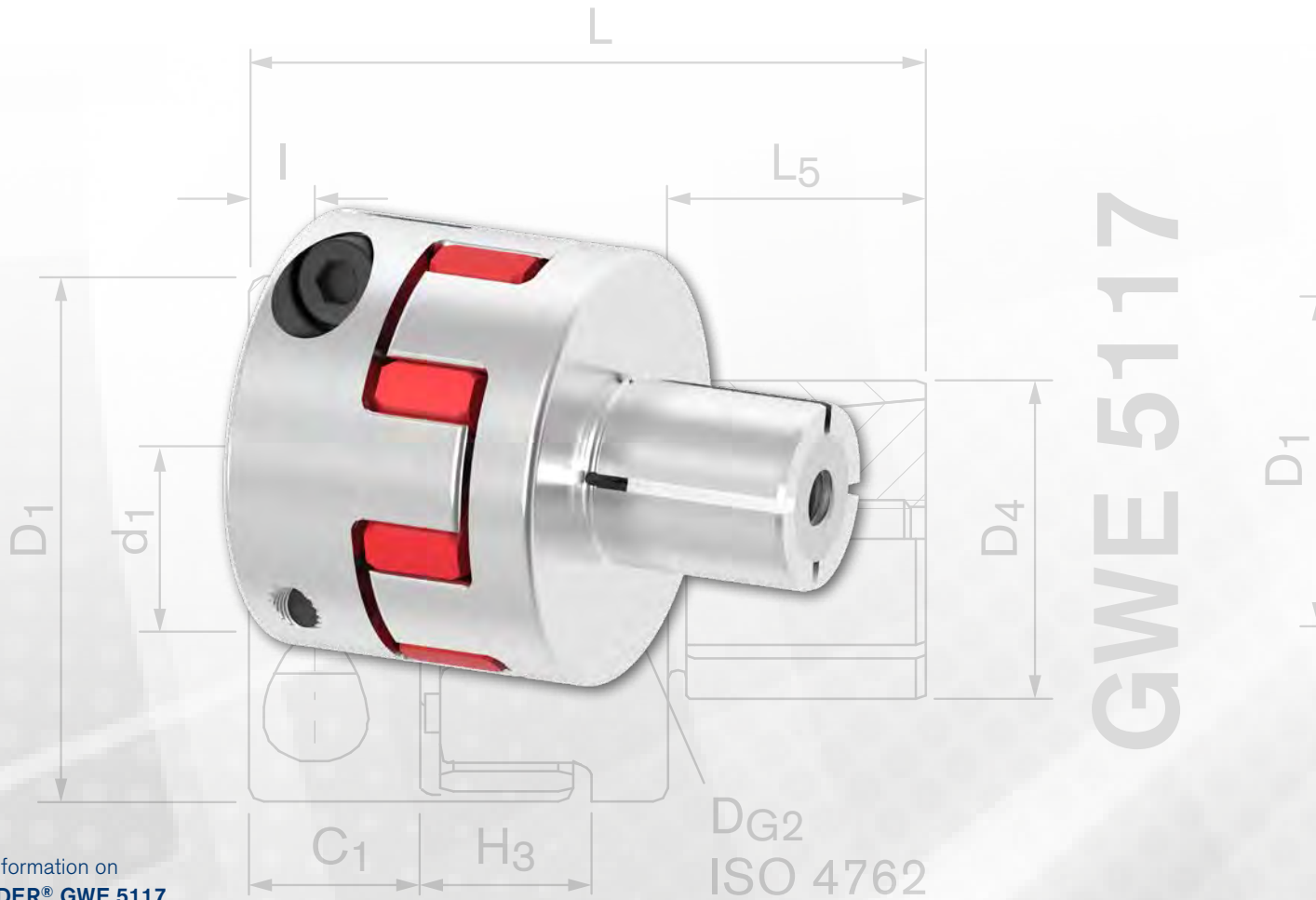

Further information on
RINGFEDER® GWE 5117
 on www.ringfeder.com

Servo-Insert coupling with clamping hubs and expanding clamps

The type **RINGFEDER® GWE 5117** is a compact and backlash-free jaw coupling with expanding mandrel and clamping hub. The expanding hub is mounted in a hollow shaft by tightening the tensioning screw. We recommend a bore tolerance of H7 for the hollow shaft. The shaft tolerance for the clamping hub should lie within the fit tolerance of 'g6' to 'h7'.

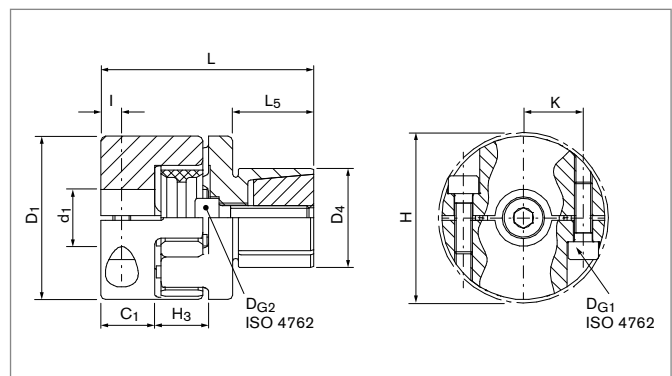

Characteristics

- Low mass through aluminium hubs
- Expanding mandrel and internal cone in steel
- Optimisation of the vibration damping through different elastomer spider hardness levels
- As standard in size 14 to 28 with red elastomer spider
- Puncture-proof and electrically insulating
- Coupling hubs optionally with keyways in accordance with DIN 6885-1

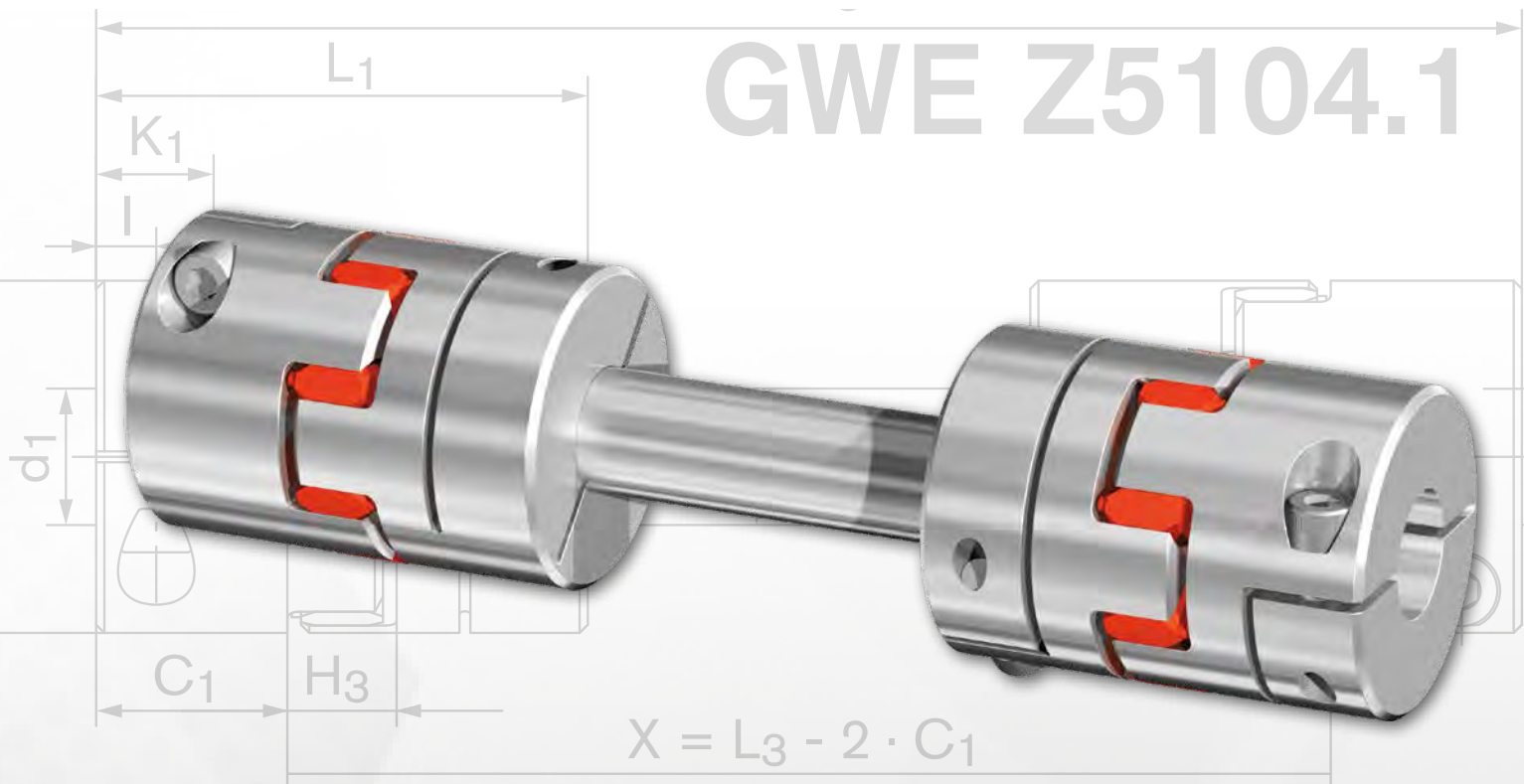

Further information on
RINGFEDER® GWE Z5104.1
 on www.ringfeder.com

Servo-Insert coupling with clamping hubs for large shaft spacings

The backlash-free jaw coupling of the **RINGFEDER® GWE Z5104.1** series that is designed as a torsionally flexible intermediate shaft is used where torque or rotation need to be transmitted with the greatest possible angle precision and a large shaft separation needs to be bridged. It comprises two RINGFEDER® GWE 5104, connected by a precision hollow shaft in steel. The shaft tolerance should lie within the fit tolerance of 'g6' to 'h7'.

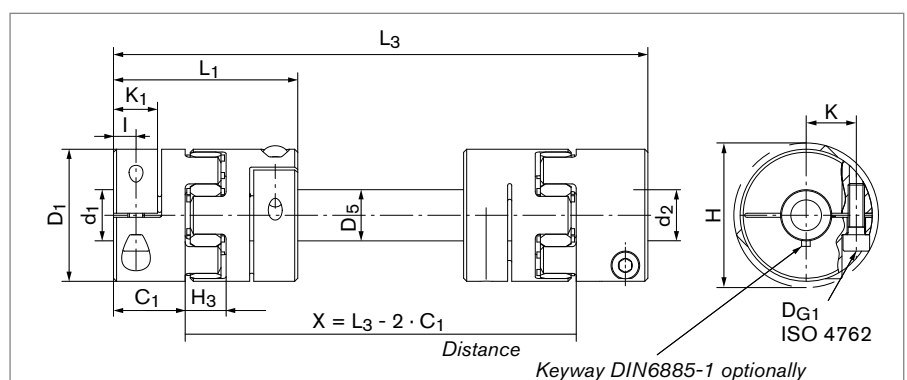

Characteristics

- Low mass through aluminium hubs
- Shaft separation of up to 3000 mm can be bridged
- Optimisation of the vibration damping through different elastomer spider hardness levels
- Puncture-proof and electrically insulating
- As standard with red elastomer spider. Up to size 55 in 98 Shore A and from size 65 in 95 Shore A
- Coupling hubs optionally with keyways in accordance with DIN 6885-1

GWE Z5106.1



Further information on
RINGFEDER® GWE Z5106.1
on www.ringfeder.com

Servo-Insert coupling with clamping hubs in split hub design for large shaft spacings

As for the GWE Z5104.1 this balancing coupling RINGFEDER® GWE Z5106.1 is also used to bridge large shaft separations. The clamping hubs in a half shell structure mean that the known benefits are supplemented by the advantage of single radial assembly on the previously aligned shafts. It comprises two RINGFEDER® GWE 5106, connected by an aluminium precision intermediate pipe. The shaft tolerance should lie within the fit tolerance of 'g6' to 'h7'.

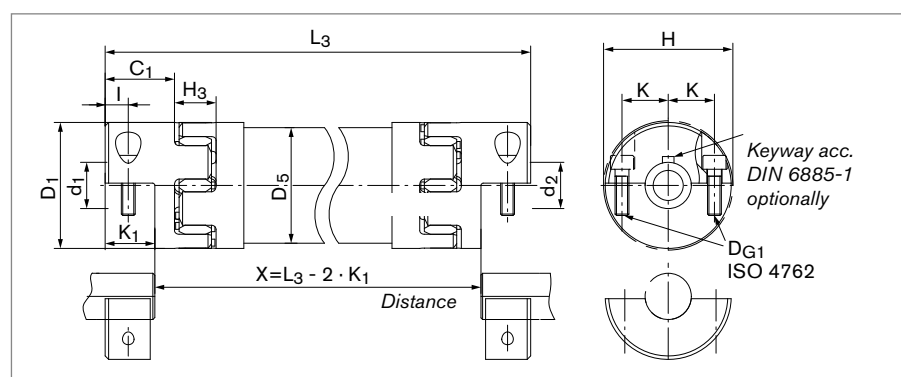

Characteristics

- Low mass through aluminium hubs and precision intermediate tube
- Optimisation of the vibration damping through different elastomer spider hardness levels
- As standard with red elastomer spider. Up to size 55 in 98 Shore A and from size 65 in 95 Shore A
- Shaft separation of up to 3000 mm can be bridged
- Puncture-proof and electrically insulating
- Coupling hubs optionally with keyways in accordance with DIN 6885-1



PORTATA MASSIMA
MAX USEFUL LOAD
30 kg.



Elastomer Jaw Couplings

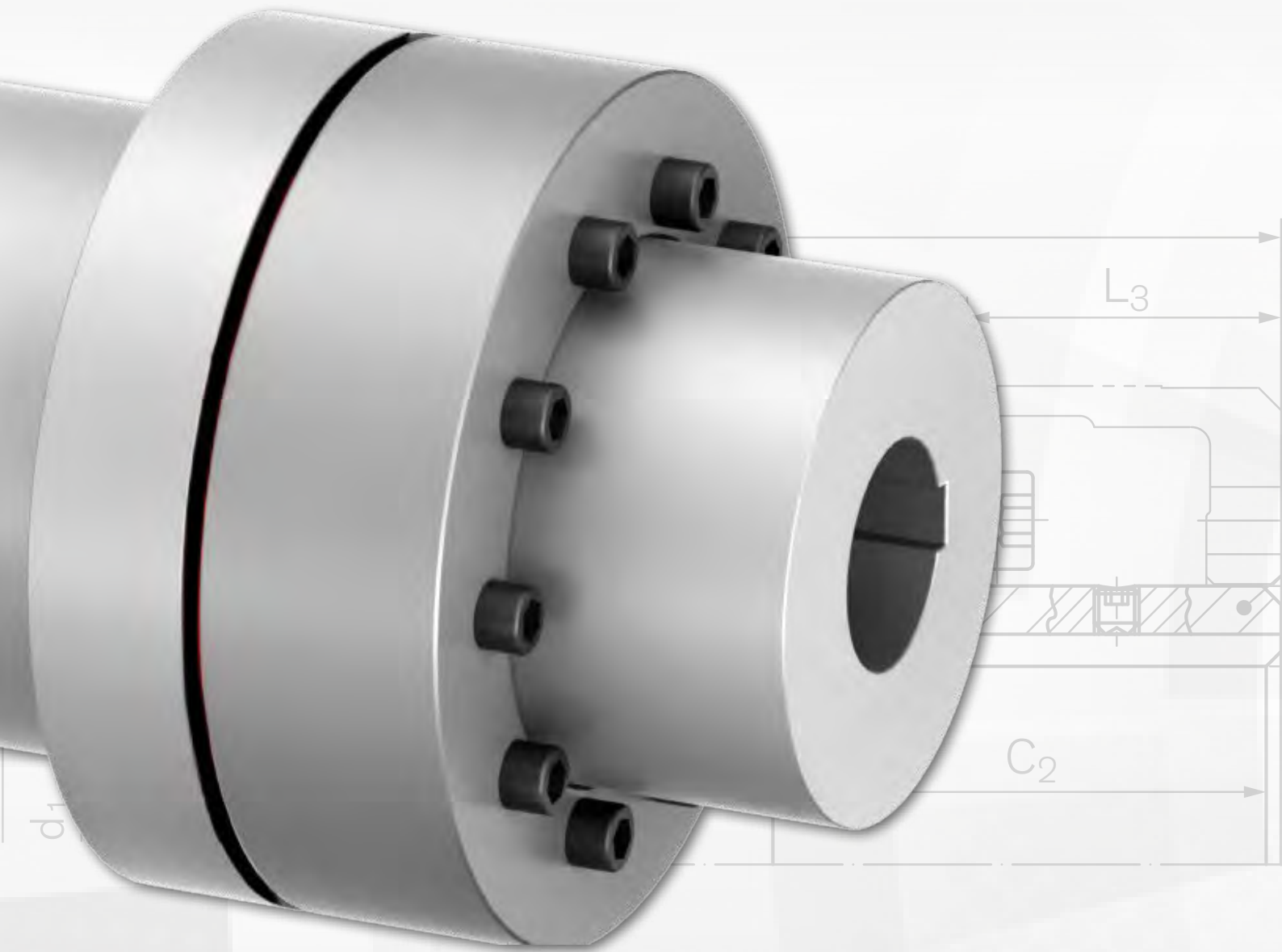

Elastomer Jaw Couplings RINGFEDER® TNM

RINGFEDER® TNM jaw couplings can be used universally in general engineering and are primarily utilised as drive and output couplings for gears, in pumps and screw compressor drives as well as in combined heat and power plants.

Characteristics · Advantages

- Torsionally flexible
- Damping of torsional vibrations
- Blind connection
- Many variations with modular design
- Individual elastomers joined to one intermediate ring
- Max. Torque: 27 – 97500 Nm
- Easy replacement of elastomers

Basic information

Intermediate rings are available in two different material hardness levels (Pb72 and Pb82) for each coupling size. The harder the intermediate ring the higher the transmittable torque but also the higher the torsion spring stiffness. The nominal torque given in the data table for the T_{KN} coupling can be transmitted continuously. The maximum coupling torque T_{Kmax} can be transmitted briefly up to 10^5 times, for example as occurs during start-up.

When the hard elastic element of Pb82 is used for multi-part coupling designs, it has to be taken into account that the maximum

transmittable torque (T_{KGmax}) is reduced. In these cases, T_{Kmax} is limited by the frictional engagement between the coupling hub and the claw ring.

Torsional vibration analyses (TVR) are performed by specialists to optimize the drive line. To this purpose, a detailed description of the oscillatory system is required, including the mechanical arrangement (spring-mass system) as well as the plant-related excitation functions. The specific coupling data such as stiffness, damping and mass moments of inertia will be supplied on request.

Size	Speed 1/min n_{max}	Torque with intermediate ring				
		Nm Pb72		Nm Pb82		
		T_{KN}	T_{Kmax}	T_{KN}	T_{Kmax}	T_{KGmax}
50	5000	13	27	20	45	-
67	5000	22	45	35	75	-
82	5000	48	100	75	160	150
97	5000	96	200	150	340	210
112	5000	150	310	230	540	540
128	5000	250	500	380	860	650
148	4500	390	800	600	1350	1350
168	4000	630	1300	980	2250	1800
194	3500	1050	2000	1650	3630	2400
214	3000	1500	3100	2400	5400	4200
240	2750	2400	4800	3700	8650	6200
265	2500	3700	7500	5800	13500	8300
295	2250	4900	10000	7550	18000	10500
330	2000	6400	13000	9900	23400	14500
370	1750	8900	18200	14000	32750	20000
415	1500	13200	27000	20500	49000	27000
480	1400	18000	36000	28000	66000	66000
575	1200	27000	54000	41000	97500	97500

T_{KN} = Nominal torque of coupling

T_{Kmax} = Max. torque of the coupling by one part design

T_{KGmax} = Max. torque of the coupling by multi-part design



Principle of the one-part design

Elastic elements replacement requires extensive dismounting operations as the driving and driven machines have to be moved axially.

Principle of the multi-part design

Elastic elements replacement only requires a minimum of work and the driving and driven machines do not need to be axially displaced.

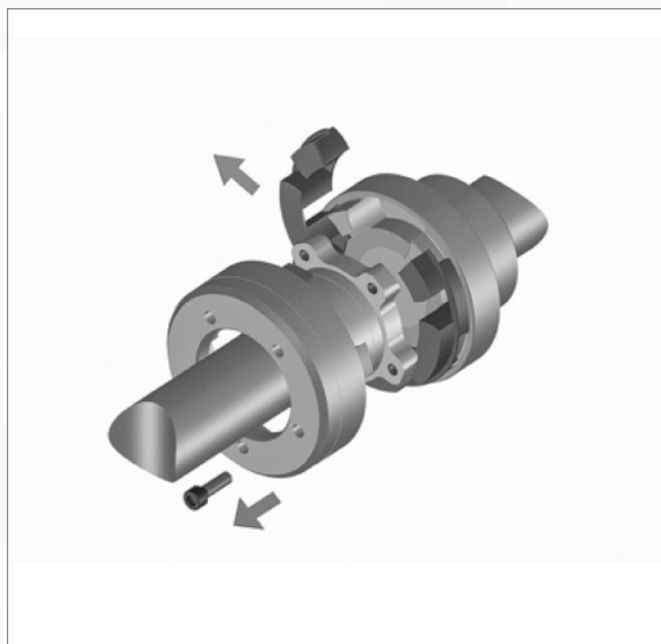
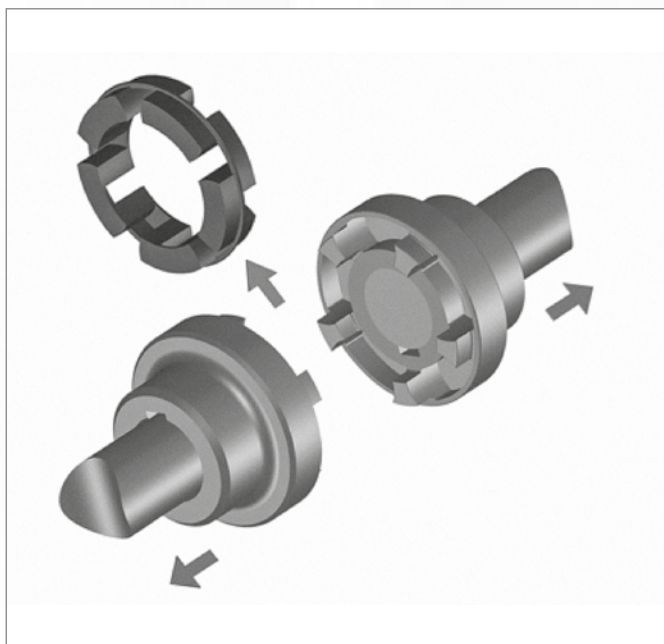

Allocation of the RINGFEDER® TNM couplings to IEC standard motors Protection rating IP 54/IP 55 (intermediate ring Pb72)

Size	Motor	kW		kW		kW		kW		Cyl. shaft end d x L by rotary speed of	
		n= 3.000 min ⁻¹	Coupling size	n= 1.500 min ⁻¹	Coupling size	n= 1.000 min ⁻¹	Coupling size	n= 750 min ⁻¹	Coupling size	= 3000 min ⁻¹	≤ 3000 min ⁻¹
56	-	0,09	50	0,06	50	0,04	50	-	-	9x20	9x20
56	-	0,12	50	0,09	50	0,05	50	-	-	9x20	9x20
63	-	0,18	50	0,12	50	0,06	50	-	-	11x23	11x23
63	-	0,25	50	0,18	50	0,09	50	-	-	11x23	11x23
71	-	0,37	50	0,25	50	0,18	50	0,09	50	14x30	14x30
71	-	0,55	50	0,37	50	0,25	50	0,12	50	14x30	14x30
80	-	0,75	50	0,55	50	0,37	50	0,18	50	19x40	19x40
80	-	1,1	50	0,75	50	0,55	50	0,25	50	19x40	19x40
90	S	1,5	67	1,1	67	0,75	67	0,37	67	24x50	24x50
90	L	2,2	67	1,5	67	1,1	67	0,55	67	24x50	24x50
100	L	3	67	2,2	82	1,5	67	0,75	67	28x60	28x60
100	L	-	-	3	82	-	-	1,1	67	28x60	28x60
112	M	4	67	5	82	2,2	82	1,5	82	28x60	28x60
132	S	5,5	97	5,5	97	3	97	2,2	97	38x80	38x80
132	S	7,5	97	-	-	-	-	-	-	38x80	38x80
132	M	-	-	7,5	-	4	97	3	97	38x80	38x80
132	M	-	-	-	97	5,5	97	-	-	42x110	42x110
160	M	11	97	11	-	7,5	97	4	97	42x110	42x110
160	M	15	97	-	97	-	-	5,5	97	42x110	42x110
160	L	18,5	112	15	-	11	112	7,5	112	48x110	48x110
180	M	22	112	18,5	112	-	-	-	-	48x110	48x110
180	L	-	-	22	112	15	128	11	128	55x110	55x110
200	L	30	128	30	128	18,5	128	15	128	55x110	55x110
200	L	37	128	-	148	22	128	-	-	60x140	60x140
225	S	-	-	37	-	-	-	18,5	148	60x140	60x140
225	M	45	128	45	148	30	148	22	148	65x140	65x141
250	M	55	148	55	148	37	168	30	168	75x140	75x140
280	S	75	18	75	168	45	168	37	168	75x140	75x140
280	M	90	148	90	168	55	194	45	194	80x170	80x170
315	S	110	168	110	194	75	194	55	194	80x170	80x170
315	M	132	168	132	194	90	194	75	214	80x170	80x170
315	L	160	168	160	214	110	214	90	214	80x170	80x170
315	L	200	194	200	240	132	240	110	240	80x170	80x170
315	L	-	-	-	-	160	240	132	240	80x170	80x170
315	-	250	194	250	240	200	240	160	265	85x170	85x170
315	-	315	214	315	265	250	265	200	265	85x170	85x170
355	-	355	214	355	265	315	295	250	295	95x170	95x170
355	-	400	-	400	265	400	295	315	330	95x170	95x170
355	-	500	-	500	295	-	-	-	-	95x170	95x170
400	-	560	-	560	295	450	330	355	330	110x210	110x210
400	-	630	-	630	330	500	330	400	330	110x210	110x210
400	-	710	-	710	330	560	370	450	370	110x210	110x210
450	-	800	-	800	330	630	370	500	370	120x210	120x210
450	-	900	-	900	370	710	370	560	370	120x210	120x210
450	-	1000	-	1000	370	800	415	630	415	120x210	120x210

The allocation of the couplings takes into account a uniform torque at the operating point (minimum operating factor 1.25) with low va-

riation and slight shocks and is valid up to an ambient temperature of +60 °C.

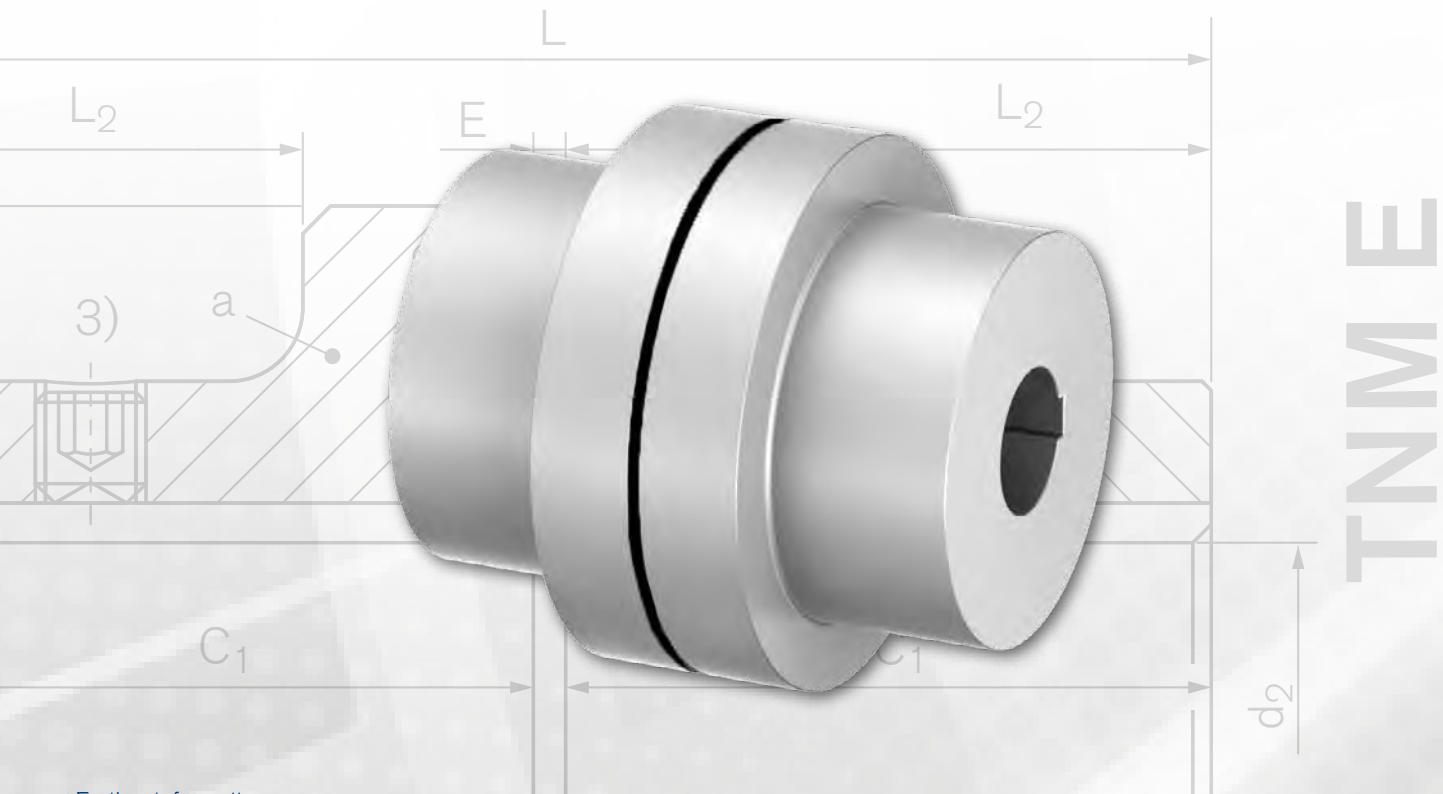

Further information on
RINGFEDER® TNM E
on www.ringfeder.com

One-part design with 2 identical coupling hubs

The **RINGFEDER® TNM E** is a torsionally flexible and puncture-proof jaw coupling. It balances out angular, radial and axial shaft offset within determined tolerances. The coupling transmits the torque via pre-compressed, elastic buffers in synthetic rubber (Perbunan; Pb) that are connected to one another into an intermediate ring. The elastic intermediate ring in synthetic rubber (Perbunan; Pb) damps impacts and torsional vibration and is electrically conductive, so that undesired static charging is avoided. The coupling can be used in any direction of rotation and installation position.

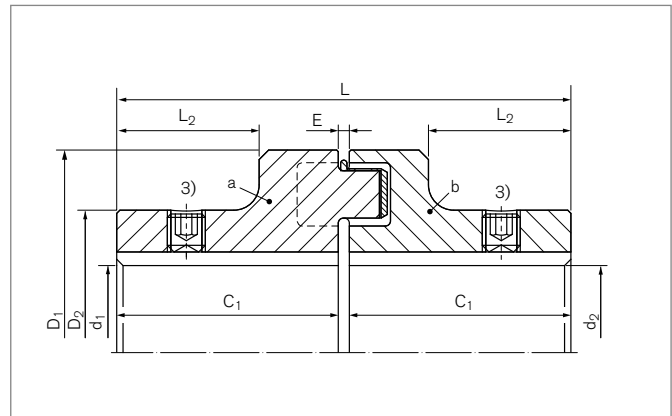

Characteristics

- Torsionally flexible, compensate for angular, radial and axial shaft misalignment
- Pre-compressed individual buffers connected to an intermediate ring
- Intermediate rings of different Shore hardness levels (standard Pb72, hard Pb82), can be used from -30 °C to $+100\text{ °C}$
- Change of the elastic intermediate ring with shift of the connected aggregates
- Bores up to 230 mm
- Torques up to $T_{Kn} = 41000\text{ Nm}$ / $T_{Kmax} = 97500\text{ Nm}$
- Speeds up to $n_{max} = 5000\text{ min}^{-1}$

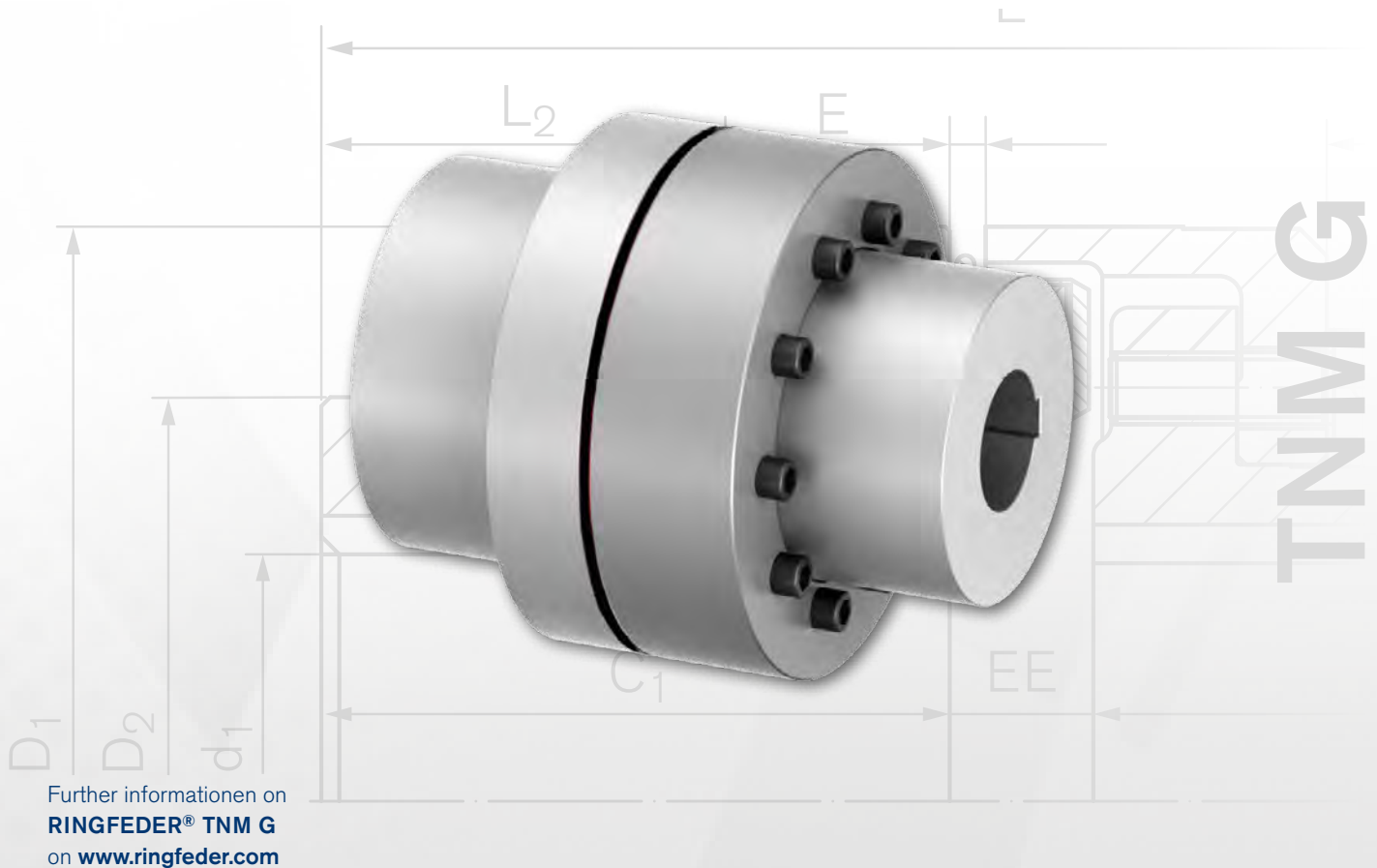

Multi-part design, to change the intermediate ring without axial movement of the driven parts

The RINGFEDER® TNM G is a torsionally elastic and puncture-proof jaw coupling with a movable jaw ring. It balances out angular, radial and axial shaft offset within determined tolerances. The coupling transmits the torque via pre-compressed, elastic buffers in synthetic rubber (Perbunan; Pb) that are connected to one another into an intermediate ring. The elastic intermediate ring in synthetic rubber (Perbunan; Pb) damps impacts and torsional vibration and is electrically conductive, so that undesired static charging is avoided. The coupling can be used in any direction of rotation and installation position. Easy separation of the coupled machines is possible because one coupling half is in two sections. The rotational direction of the drive can be inspected when the jaw ring is pushed back. One coupling half can also be lifted out radially with the corresponding

aggregate. The elastic intermediate ring can be changed without shifting the machines axially.

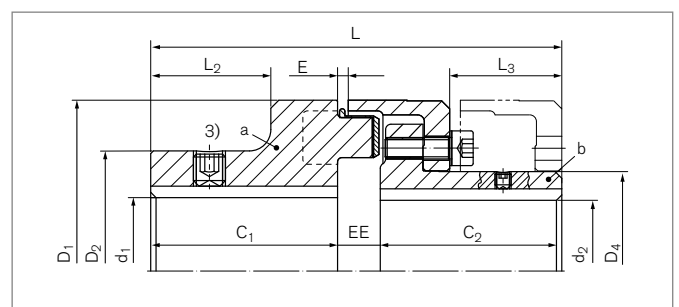

Characteristics

- Torsionally flexible, compensate for angular, radial and axial shaft misalignment
- Pre-compressed individual buffers connected to an intermediate ring
- Intermediate rings of different Shore hardness levels (standard Pb72, hard Pb82), can be used from -30 °C to $+100\text{ °C}$
- Change of the elastic intermediate ring without shift of the connected aggregates.
- Bores up to 280 mm
- Torques up to $T_{Kn} = 41000\text{ Nm}$ / $T_{Kmax} = 97500\text{ Nm}$
- Speeds up to $n_{max} = 5000\text{ min}^{-1}$

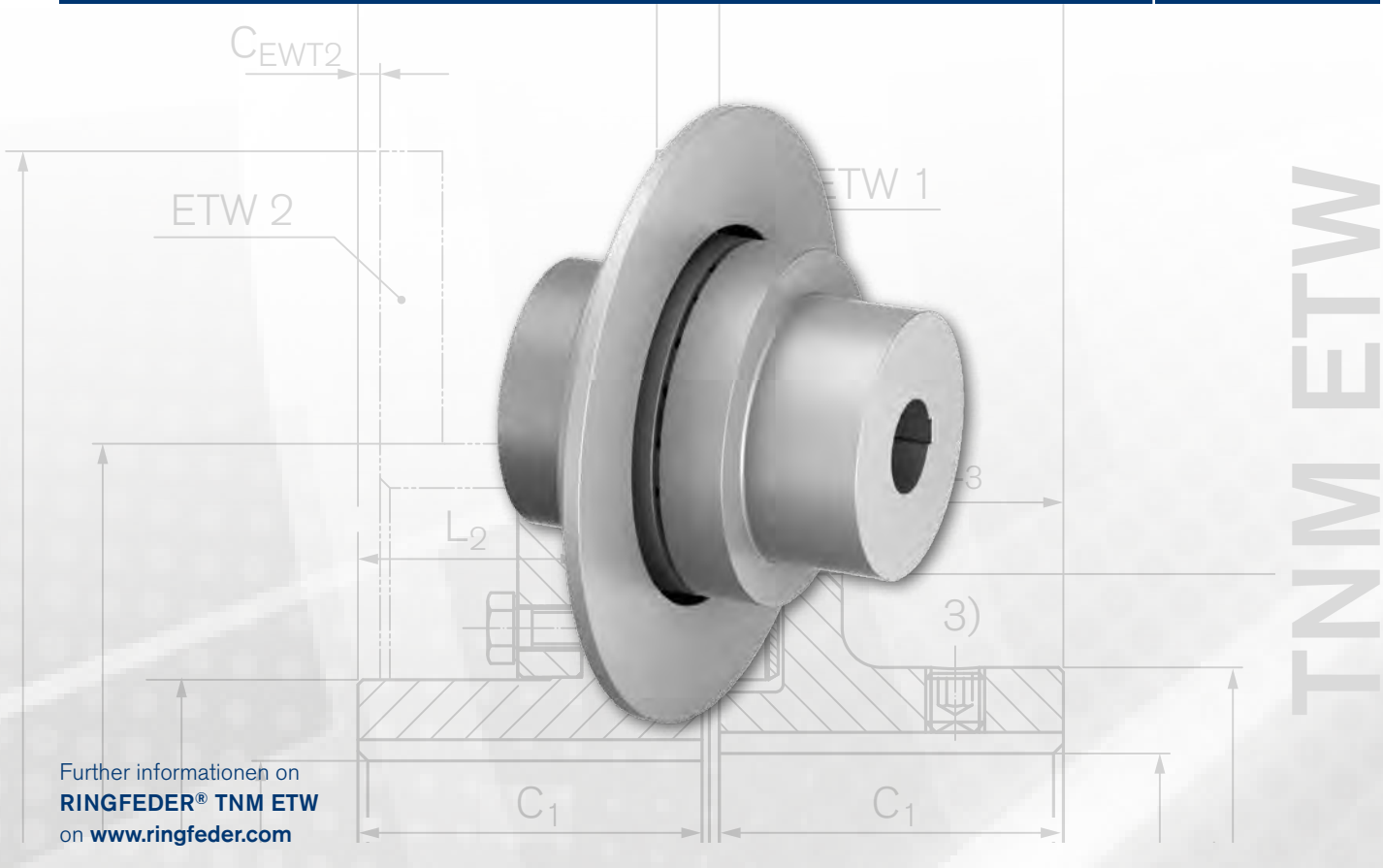

Further information on
RINGFEDER® TNM ETW
on www.ringfeder.com

One part design with brake disc

The **RINGFEDER® TNM ETW** is a torsionally elastic and puncture-proof jaw coupling with a brake disc. It balances out angular, radial and axial shaft offset within determined tolerances. The coupling transmits the torque via pre-compressed, elastic buffers in synthetic rubber (Perbunan; Pb) that are connected to one another into an intermediate ring. The elastic intermediate ring in synthetic rubber (Perbunan; Pb) damps impacts and torsional vibration and is electrically conductive, so that undesired static charging is avoided. The coupling can be used in any direction of rotation and installation position.

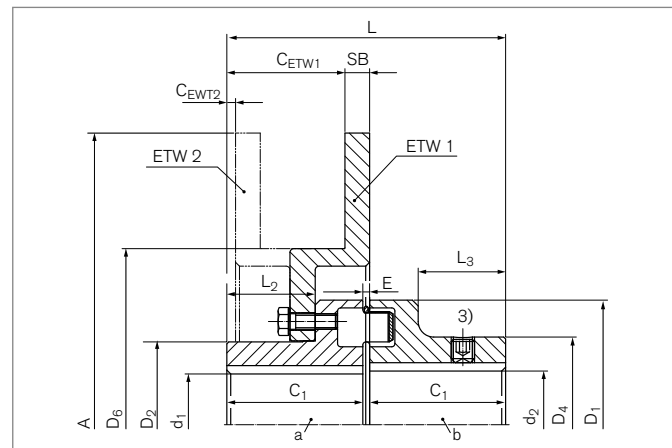

Characteristics

- Torsionally flexible, compensate for angular, radial and axial shaft misalignment
- Pre-compressed individual buffers connected to an intermediate ring.
- Intermediate rings of different Shore hardness levels (standard Pb72, hard Pb82), can be used from -30 °C to $+100\text{ °C}$
- Brake disc in GGG, other materials on request
- Change of the elastic intermediate ring with shift of the connected aggregates.
- Bores up to 230 mm
- Torques up to $T_{Kn} = 41000\text{ Nm}$ / $T_{Kmax} = 97500\text{ Nm}$
- Speeds up to $n_{max} = 5000\text{ min}^{-1}$

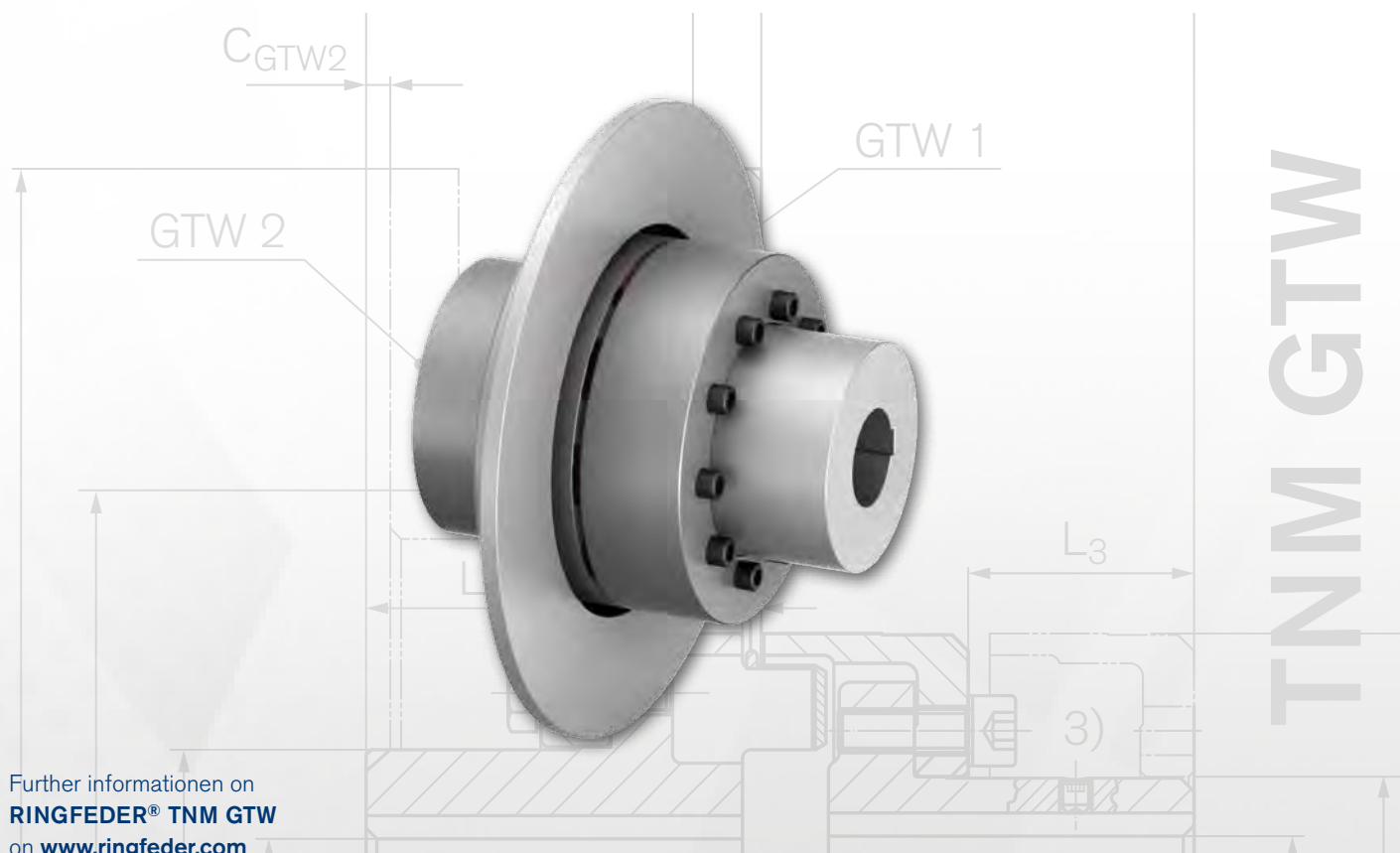

TNM GTW

Further information on
RINGFEDER® TNM GTW
on www.ringfeder.com

Multi-part design, to change the intermediate ring without axial movement of the driven parts with brake disc

The RINGFEDER® TNM GTW is a torsionally elastic and puncture-proof jaw coupling with a brake disc and a movable jaw ring. It balances out angular, radial and axial shaft offset within determined tolerances. The coupling transmits the torque via pre-compressed, elastic buffers in synthetic rubber (Perbunan; Pb) that are connected to one another into an intermediate ring. The elastic intermediate ring in synthetic rubber (Perbunan; Pb) damps impacts and torsional vibration and is electrically conductive, so that undesired static charging is avoided. The coupling can be used in any direction of rotation and installation position. Easy separation of the coupled machines is possible because one coupling half is in two sections. The rotational direction of the drive can be inspected when the jaw ring is pushed back. One coupling half can also be lifted out radially with the corresponding aggregate. The elastic intermediate ring can be changed without shifting the machines axially.

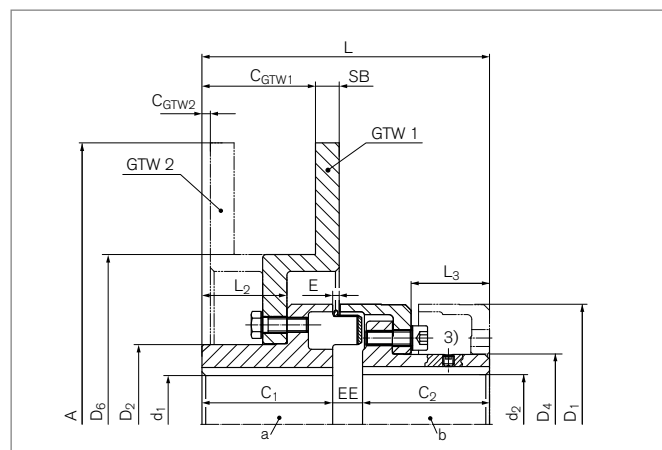

Characteristics

- Torsionally flexible, compensate for angular, radial and axial shaft misalignment
- Pre-compressed individual buffers connected to an intermediate ring
- Intermediate rings of different Shore hardness levels (standard Pb72, hard Pb82), can be used from -30 °C to $+100\text{ °C}$
- Brake disc in GGG, other materials on request
- Change of the elastic intermediate ring without shift of the connected aggregates.
- Bores up to 280 mm
- Torques up to $T_{Kn} = 41000\text{ Nm}$ / $T_{Kmax} = 97500\text{ Nm}$
- Speeds up $n_{max} = 5000\text{ min}^{-1}$

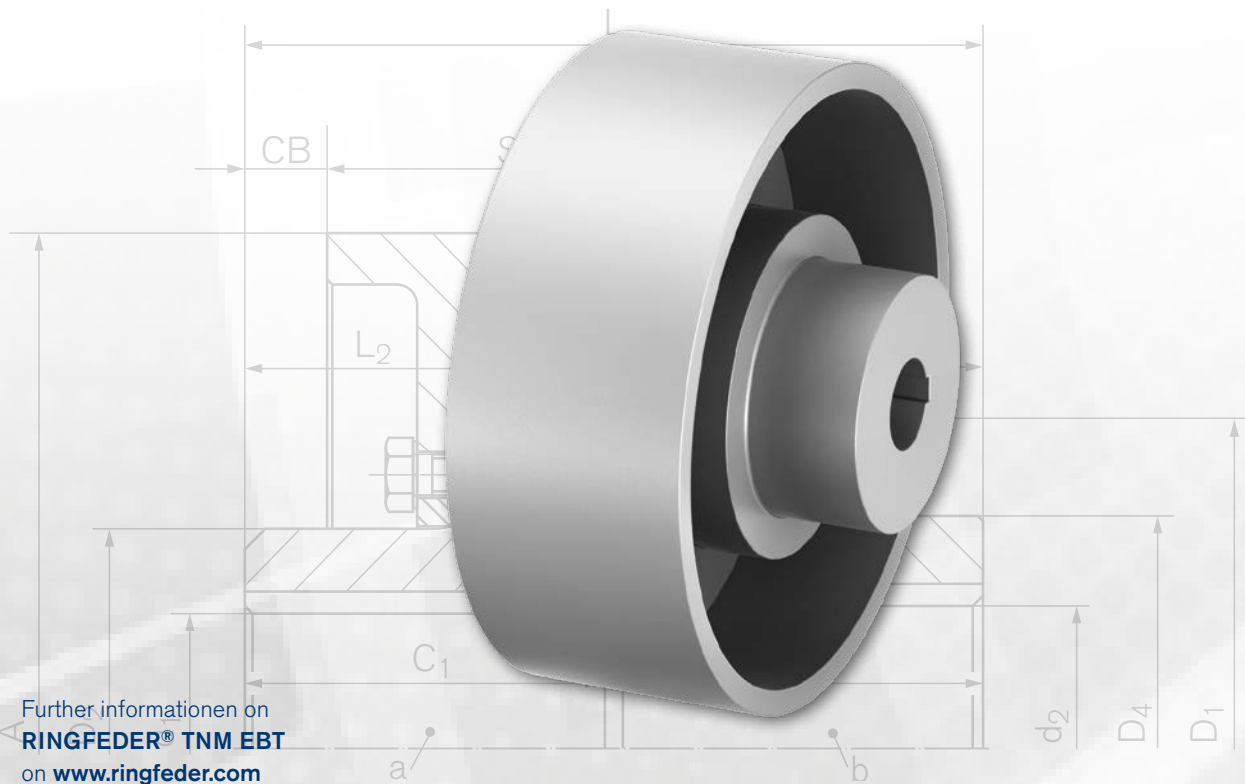

TNM EBT

One part design with brake drum acc. to DIN 15431

Die RINGFEDER® TNM EBT is a torsionally elastic and puncture-proof jaw coupling with a brake drum. It balances out angular, radial and axial shaft offset within determined tolerances. The coupling transmits the torque via pre-compressed, elastic buffers in synthetic rubber (Perbunan; Pb) that are connected to one another into an intermediate ring. The elastic intermediate ring in synthetic rubber (Perbunan; Pb) damps impacts and torsional vibration and is electrically conductive, so that undesired static charging is avoided. The coupling can be used in any direction of rotation and installation position.

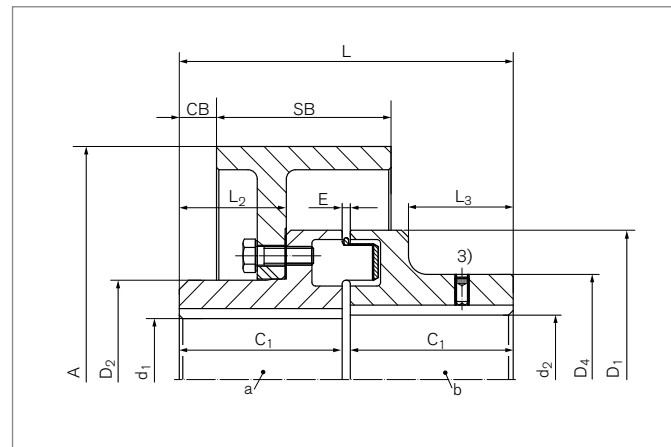

Characteristics

- Torsionally flexible, compensate for angular, radial and axial shaft misalignment
- Pre-compressed individual buffers connected to an intermediate ring
- Intermediate rings of different Shore hardness levels (standard Pb72, hard Pb82), can be used from -30 °C to $+100\text{ °C}$
- Brake drum in GGG, other materials on request
- Change of the elastic intermediate ring with shift of the connected aggregates.
- Bores up to 230 mm
- Torques up to $T_{Kn} = 41000\text{ Nm}$ / $T_{Kmax} = 97500\text{ Nm}$
- Speeds up to $n_{max} = 5000\text{ min}^{-1}$

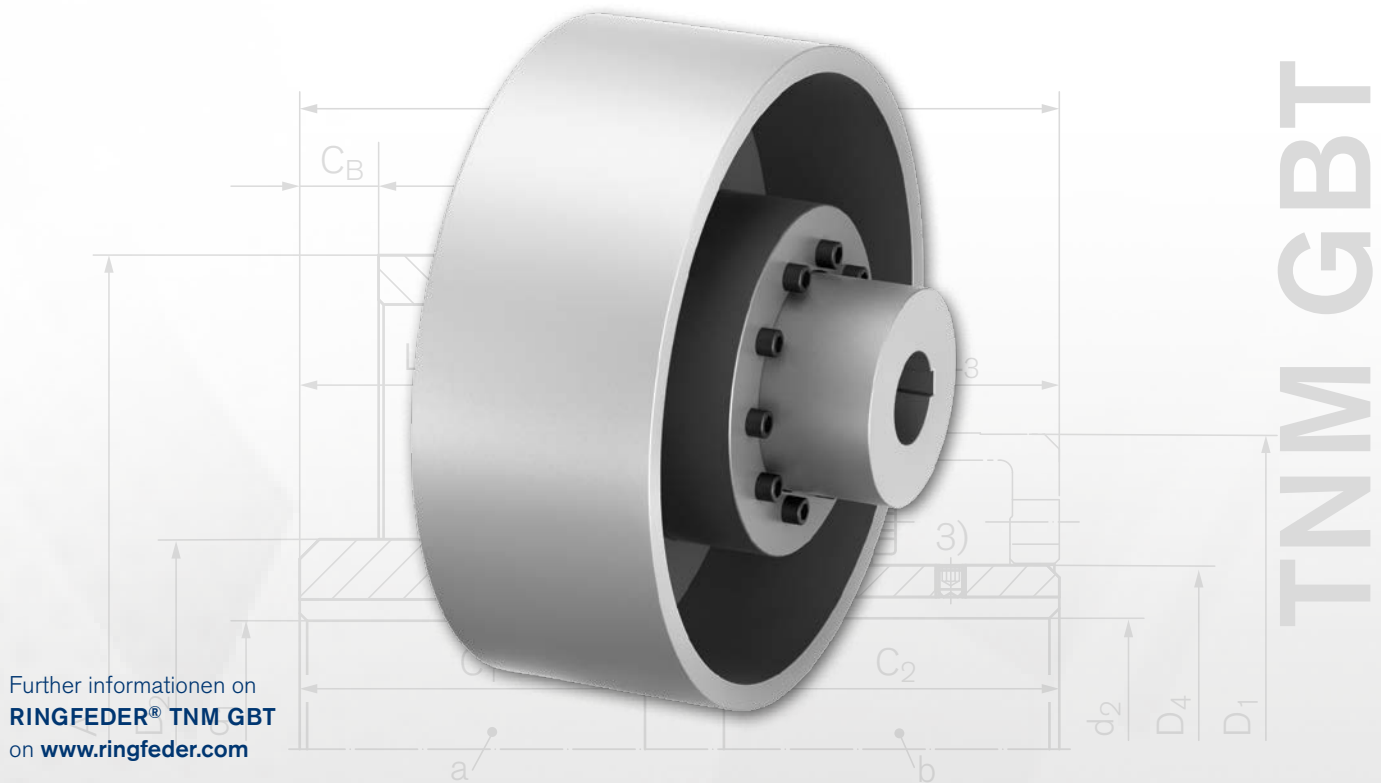

Further information on
RINGFEDER® TNM GBT
on www.ringfeder.com

Multi-part design, to change the intermediate ring without axial movement of the driven parts with brake drum acc. to DIN 15431

Die RINGFEDER® TNM GBT is a torsionally elastic and puncture-proof jaw coupling with brake drum and a movable jaw ring. It balances out angular, radial and axial shaft offset within determined tolerances. The coupling transmits the torque via pre-compressed, elastic buffers in synthetic rubber (Perbunan; Pb) that are connected to one another into an intermediate ring. The elastic intermediate ring in synthetic rubber (Perbunan; Pb) damps impacts and torsional vibration and is electrically conductive, so that undesired static charging is avoided. The coupling can be used in any direction of rotation and installation position. Easy separation of the coupled machines is possible because one coupling half is in two sections. The rotational direction of the drive can be inspected when the jaw ring is pushed back. One coupling half can also be lifted out radially with the corresponding aggregate. The elastic intermediate ring can be changed without shifting the machines axially.

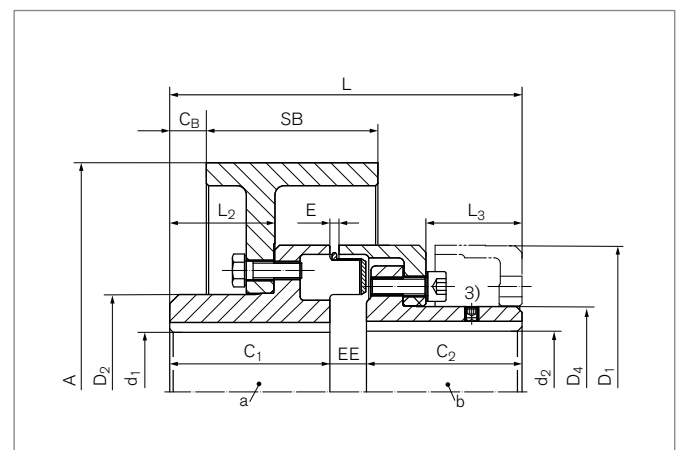

Characteristics

- Torsionally flexible, compensate for angular, radial and axial shaft misalignment
- Pre-compressed individual buffers connected to an intermediate ring
- Intermediate rings of different Shore hardness levels (standard Pb72, hard Pb82), can be used from -30 °C to $+100\text{ °C}$
- Brake drum in GGG, other materials on request
- Change of the elastic intermediate ring without shift of the connected aggregates.
- Bores up to 280 mm
- Torques up to $T_{Kn} = 41000\text{ Nm}$ / $T_{Kmax} = 97500\text{ Nm}$
- Speeds up to $n_{max} = 5000\text{ min}^{-1}$

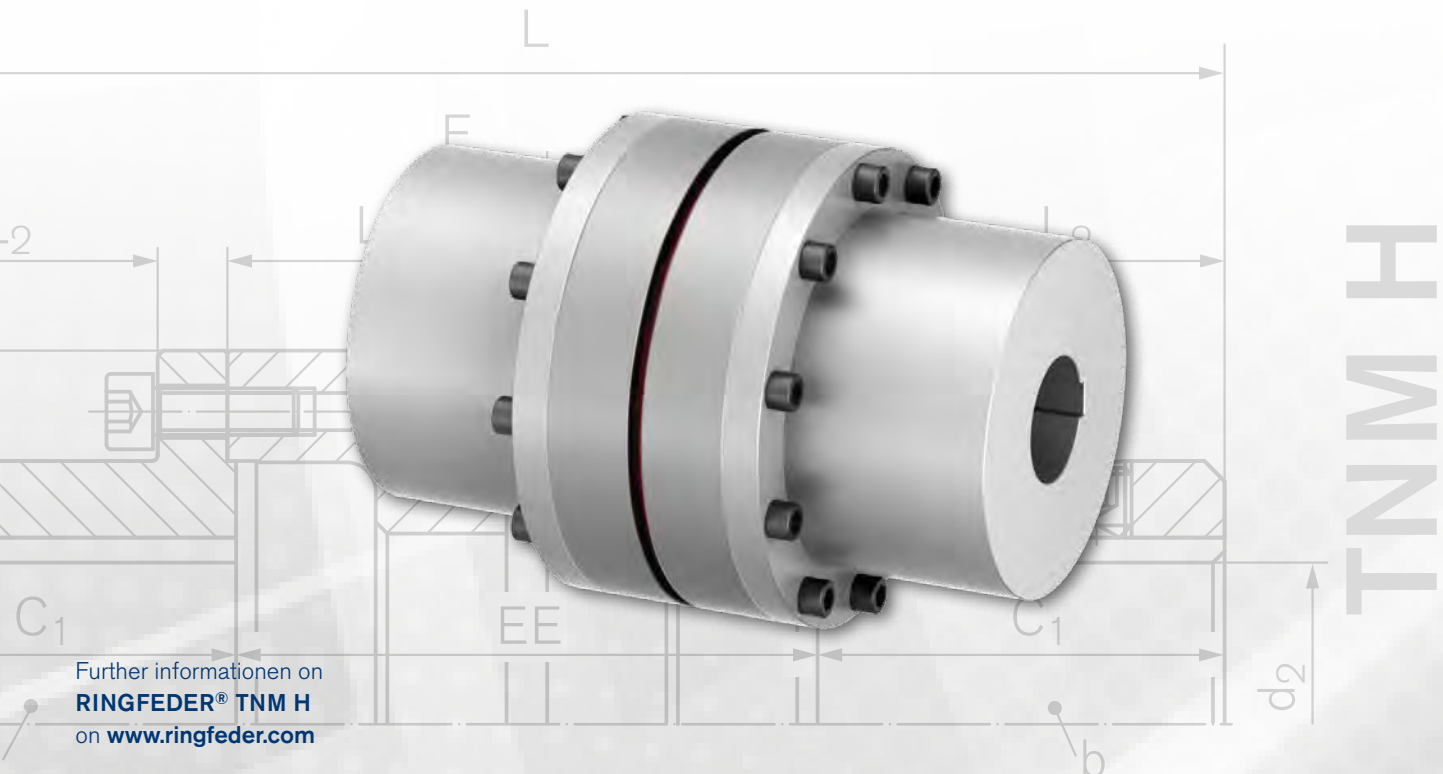

Further information on
RINGFEDER® TNM H
on www.ringfeder.com

Multi-part design, to remove the intermediate spacer. Disassembly of the pump impeller without axial movement of the driven parts

Die **RINGFEDER® TNM H** is a torsionally elastic and puncture-proof jaw coupling with an intermediate piece that can be lifted out, primarily for pump drives. It balances out angular, radial and axial shaft offset within determined tolerances. The coupling transmits the torque via pre-compressed, elastic buffers in synthetic rubber (Perbunan; Pb) that are connected to one another into an intermediate ring. The elastic intermediate ring in synthetic rubber (Perbunan; Pb) damps impacts and torsional vibration and is electrically conductive, so that undesired static charging is avoided. The coupling can be used in any direction of rotation and installation position. Radial installation and removal of the intermediate sleeve are possible because both coupling halves are in two sections. The dismounting dimension between the flange hubs is available to change the elastic intermediate ring or removal of the bearing bracket of a centrifugal pump without moving the motor. When the intermediate sleeve has been dismounted it is also simple to carry out a check on the rotational direction of the drive.

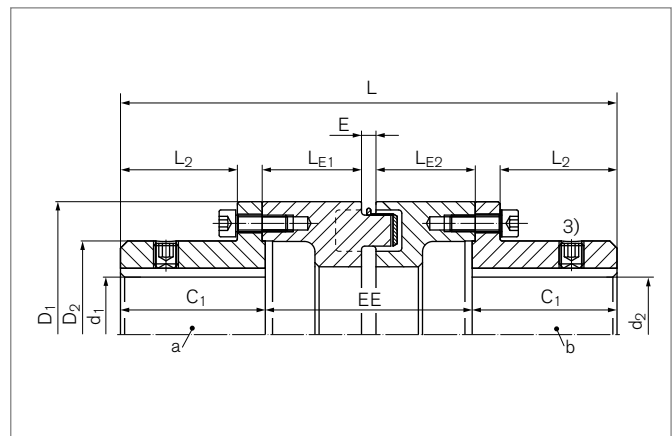

Characteristics

- Torsionally flexible, compensate for angular, radial and axial shaft misalignment
- Pre-compressed individual buffers connected to an intermediate ring
- Intermediate rings of different Shore hardness levels (standard Pb72, hard Pb82), can be used from -30 °C to $+100\text{ °C}$
- Removal of the intermediate pieces and changing of the elastic intermediate ring without moving the connected aggregates.
- Bores up to 150 mm
- Torques up to $T_{Kn} = 9900\text{ Nm}$ / $T_{Kmax} = 23400\text{ Nm}$
- Speeds up to $n_{max} = 2000\text{ min}^{-1}$

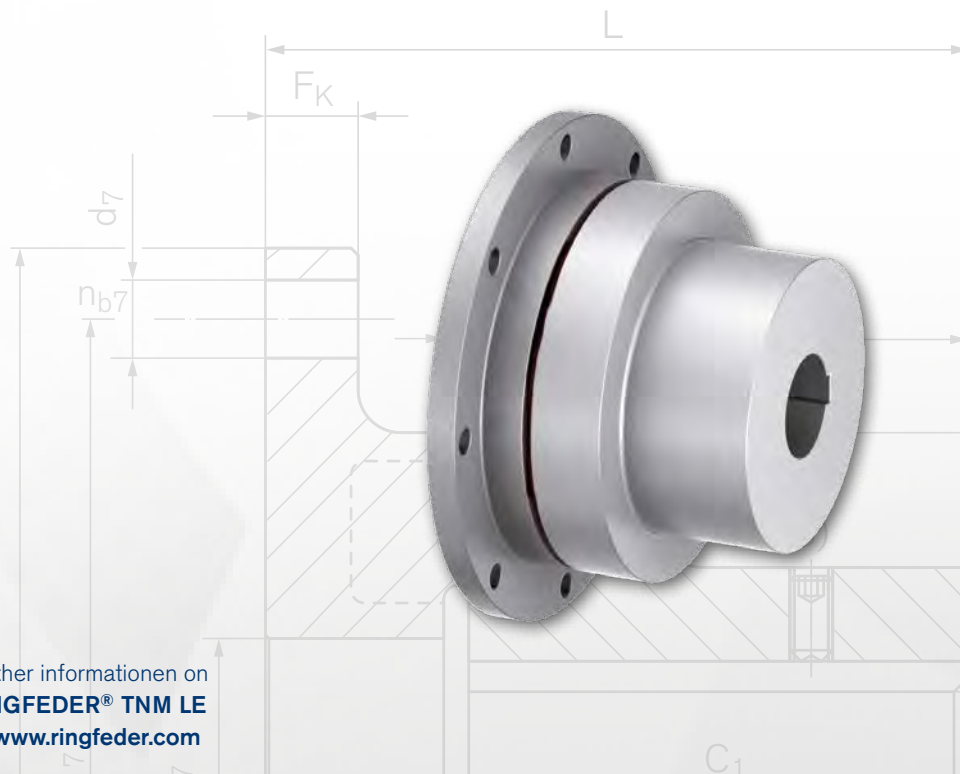

Further information on
RINGFEDER® TNM LE
on www.ringfeder.com

TNM LE

One part design with flange, externally centred

The RINGFEDER® TNM LE is a torsionally elastic and puncture-proof jaw coupling with screw-down flange. It balances out angular, radial and axial shaft offset within determined tolerances. The coupling transmits the torque via pre-compressed, elastic buffers in synthetic rubber (Perbunan; Pb) that are connected to one another into an intermediate ring. The elastic intermediate ring in synthetic rubber (Perbunan; Pb) damps impacts and torsional vibration and is electrically conductive, so that undesired static charging is avoided. The coupling can be used in any direction of rotation and installation position.

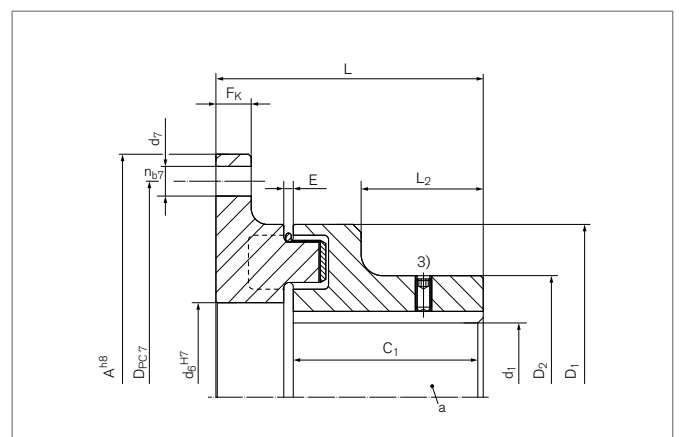

Characteristics

- Torsionally flexible, compensate for angular, radial and axial shaft misalignment
- Pre-compressed individual buffers connected to an intermediate ring
- Intermediate rings of different Shore hardness levels (standard Pb72, hard Pb82), can be used from -30 °C to $+100\text{ °C}$
- Changing of the elastic intermediate ring with movement of the connected aggregates.
- Bores up to 230 mm
- Torques up to $T_{Kn} = 41000\text{ Nm}$ / $T_{Kmax} = 97500\text{ Nm}$
- Speeds up to $n_{max} = 5000\text{ min}^{-1}$

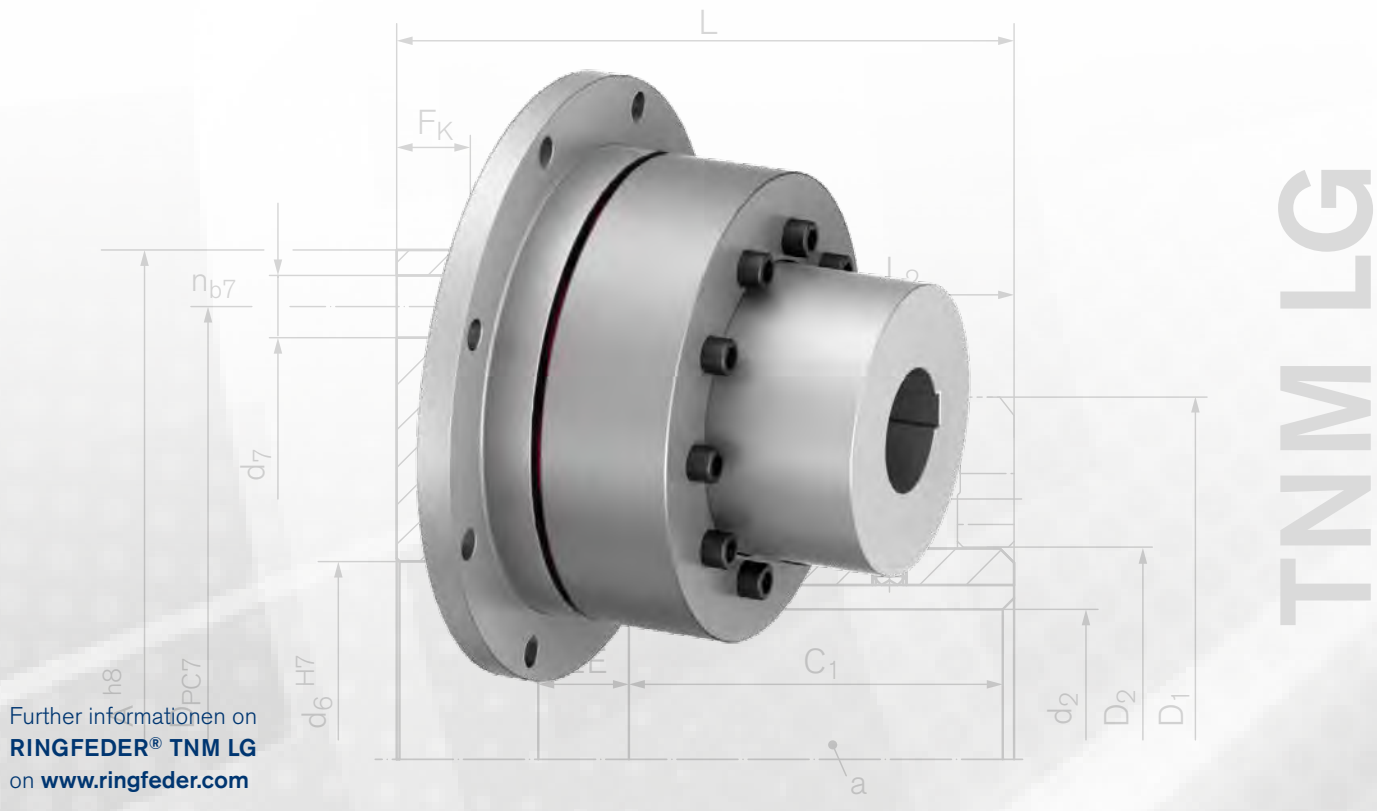

TNM LG

Multi-part design, to change the intermediate ring without axial movement of the driven parts with flange, externally centred

The RINGFEDER® TNM LG is a torsionally elastic and puncture-proof jaw coupling with screw-down flange and moveable jaw ring. It balances out angular, radial and axial shaft offset within determined tolerances. The coupling transmits the torque via pre-compressed, elastic buffers in synthetic rubber (Perbunan; Pb) that are connected to one another into an intermediate ring. The elastic intermediate ring in synthetic rubber (Perbunan; Pb) damps impacts and torsional vibration and is electrically conductive, so that undesired static charging is avoided. The coupling can be used in any direction of rotation and installation position. Easy separation of the coupled machines is possible because one coupling half is in two sections. The rotational direction of the drive can be inspected when the jaw ring is pushed back. One coupling half can also be lifted out radially with the corresponding aggregate. The elastic intermediate ring can be changed without shifting the machines axially.

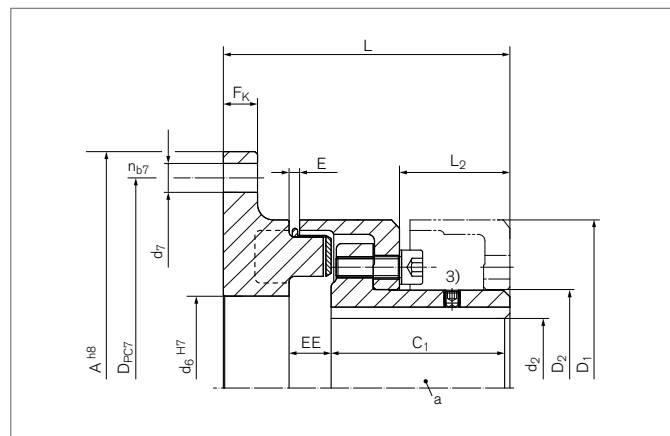

Characteristics

- Torsionally flexible, compensate for angular, radial and axial shaft misalignment
- Pre-compressed individual buffers connected to an intermediate ring
- Intermediate rings of different Shore hardness levels (standard Pb72, hard Pb82), can be used from -30 °C to $+100\text{ °C}$
- Changing of the elastic intermediate ring without moving the connected aggregates.
- Bores up to bis 280 mm
- Torques up to $T_{Kn} = 41000\text{ Nm}$ / $T_{Kmax} = 97500\text{ Nm}$
- Speeds up to $n_{max} = 5000\text{ min}^{-1}$

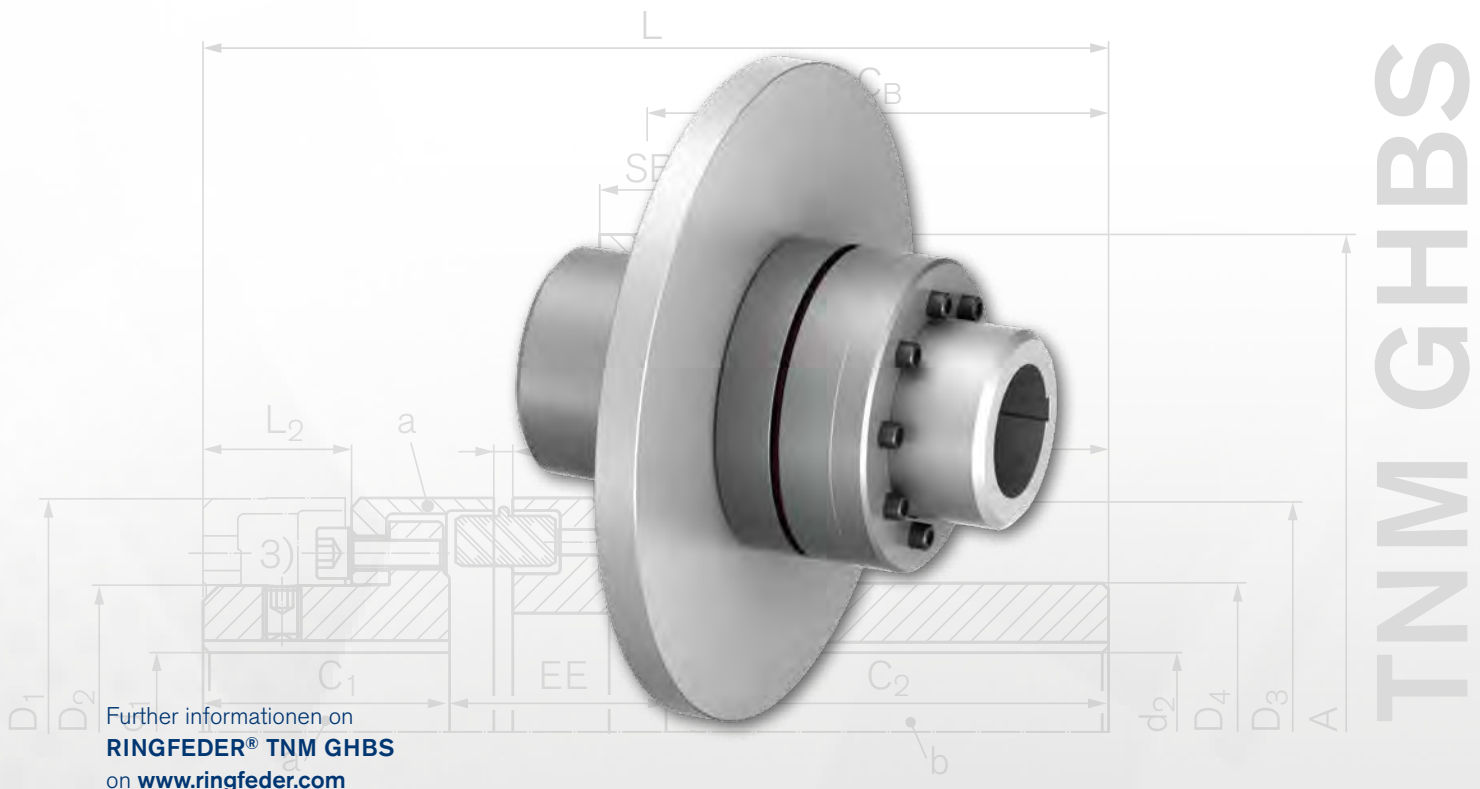

TNM GHBS

Further information on
RINGFEDER® TNM GHBS
on www.ringfeder.com

With brake disc in steel, multi-part design, to change the intermediate ring and the brake disc without axial movement of the driven parts

The RINGFEDER® TNM GHBS is a torsionally elastic and puncture-proof jaw coupling with brake disc and moveable jaw ring. It balances out angular, radial and axial shaft offset within determined tolerances. The coupling transmits the torque via pre-compressed, elastic buffers in synthetic rubber (Perbunan; Pb) that are connected to one another into an intermediate ring. The elastic intermediate ring in synthetic rubber (Perbunan; Pb) damps impacts and torsional vibration and is electrically conductive, so that undesired static charging is avoided. The coupling can be used in any direction of rotation and installation position. Easy separation of the coupled machines is possible because one coupling half is in two sections. The rotational direction of the drive can be inspected when the jaw ring is pushed back. One coupling half can also be lifted out radially with the corresponding aggregate. The elastic intermediate ring and the brake disc can be changed without shifting the machines axially.

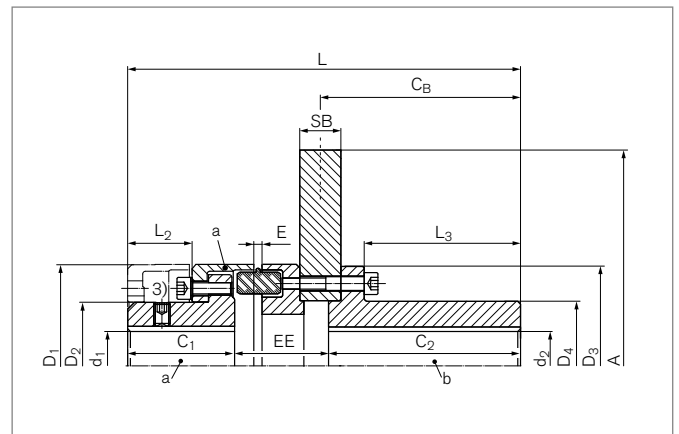

Characteristics

- Torsionally flexible, compensate for angular, radial and axial shaft misalignment
- Pre-compressed individual buffers connected to an intermediate ring
- Intermediate rings of different Shore hardness levels (standard Pb72, hard Pb82), can be used from -30 °C to $+100\text{ °C}$
- Changing of the elastic intermediate ring and the brake disc without moving the connected aggregates.
- Bores up to 150 mm
- Torques up to $T_{Kn} = 7550\text{ Nm}$ / $T_{Kmax} = 10500\text{ Nm}$
- Speeds up to $n_{max} = 2250\text{ min}^{-1}$

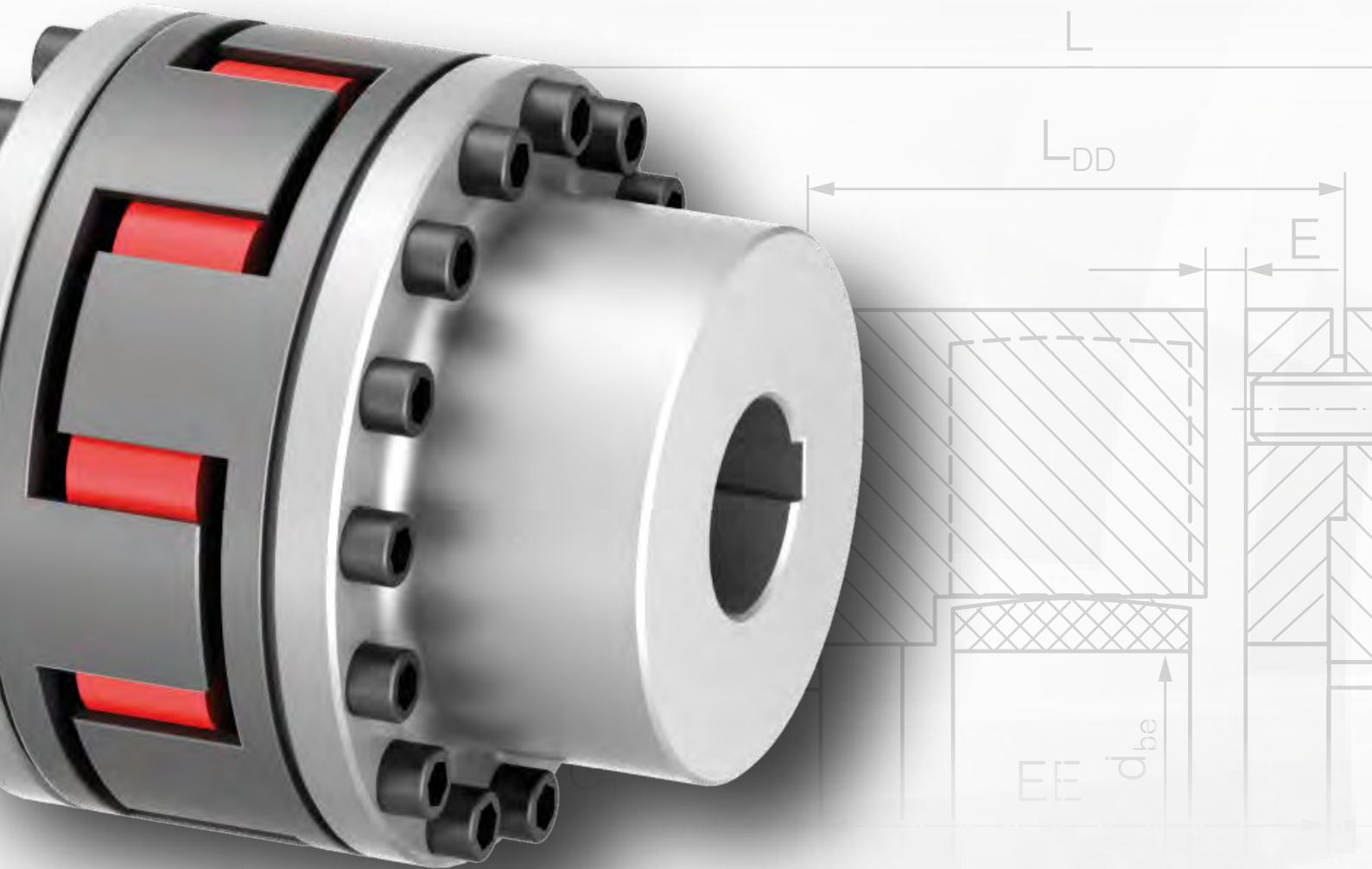

Elastomer Jaw Couplings RINGFEDER® TNS

RINGFEDER® TNS jaw couplings are used primarily as robust known drive components in heavy load areas such as drives in mining and ore production machines, in smelting and steelworks technology, cement works, as a connection coupling in bridge, container and casting cranes or in connection with fluid couplings in conveyor belt drives.

Characteristics · Advantages

- Torsionally flexible
- Damping of torsional vibrations
- Blind connection
- High breakage resistance through stable jaw design
- Many variations with modular design
- Large volume elastomers of different hardness levels are joined to an intermediate ring
- Max. Torque: 12–40 050 Nm

Basic information

Intermediate rings are available in four different material hardness levels (in Perbunan Pb72 and Pb82, in Vulkollan VkR and Vk60D) for each coupling size. The harder the intermediate ring the higher the transmittable torque but also the higher the torsion spring stiffness. The nominal torque given in the data table for the T_{KN} coupling can be transmitted continuously. The maximum coupling torque T_{Kmax} can be transmitted briefly up to 10^5 times, for example as occurs during start-up.

Torsional vibration analyses (TVA) are performed by specialists to optimize the drive line. To this purpose, a detailed description of the oscillatory system is required, including the mechanical arrangement (spring-mass system) as well as the plant-related excitation functions. The specific coupling data such as stiffness, damping and mass moments of inertia will be supplied on request.

Size	Torque with following buffer							
	Nm Pb72		Nm Pb82		Nm VkR		Nm Vk60D	
	T_{KN}	T_{Kmax}	T_{KN}	T_{Kmax}	T_{KN}	T_{Kmax}	T_{KN}	T_{Kmax}
50	4	12	7,3	22	15	40	-	-
70	16	48	29	87	55	160	-	-
85	24	72	40	120	75	225	110	330
100	40	120	70	210	130	390	195	585
125	70	210	128	385	250	750	370	1110
145	120	360	220	660	400	1200	600	1800
170	180	540	340	1020	630	1900	950	2850
200	330	990	590	1770	1100	3300	1650	4950
230	500	1500	900	2700	1700	5150	2580	7740
260	800	2400	1400	4200	2650	7950	3980	11940
300	1180	3540	2090	6270	3900	11070	5850	17550
360	1940	5820	3450	10350	6500	19500	9700	29100
400	2670	8010	4750	14250	8900	26700	13350	40050

T_{KN} = Nominal torque of coupling

T_{Kmax} = Max. torque of the coupling by one part design





Notes:

- Version based on type RINGFEDER® TNS S-St and flexible element VkR.
- Applies for small and medium moments of inertia on the output side.

**Allocation of the RINGFEDER® TNS couplings to IEC standard motors
Protection rating IP 54/IP 55 (intermediate ring VkR)**

for rough determination of the coupling size in accordance with operating factors.

Size	Engine	kW		kW		kW		kW		Cyl. shaft end Ø x L by rotary speed of	
		n= 3.000 min ⁻¹	Coupling size	n= 1.500 min ⁻¹	Coupling size	n= 1.000 min ⁻¹	Coupling size	n= 750 min ⁻¹	Coupling size	= 3000 min ⁻¹	≤ 3000 min ⁻¹
56	-	0,09	50	0,06	50	0,037	50	-	-	9 x 20	9 x 20
56	-	0,12	50	0,09	50	0,045	50	-	-	9 x 20	9 x 20
63	-	0,18	50	0,12	50	0,06	50	-	-	11 x 23	11 x 23
63	-	0,25	50	0,18	50	0,09	50	-	-	11 x 23	11 x 23
71	-	0,37	50	0,25	50	0,18	50	0,09	50	14 x 30	14 x 30
71	-	0,55	50	0,37	50	0,25	50	0,12	50	14 x 30	14 x 30
80	-	0,75	50	0,55	50	0,37	50	0,18	50	19 x 40	19 x 40
80	-	1,1	50	0,75	50	0,55	50	0,25	50	19 x 40	19 x 40
90	S	1,5	50	1,1	50	0,75	50	0,37	50	24 x 50	24 x 50
90	L	2,2	50	1,5	50	1,1	50	0,55	50	24 x 50	24 x 50
100	L	3	70	2,2	70	1,5	70	0,75	70	28 x 60	28 x 60
100	L	-	-	3	70	-	-	1,1	70	28 x 60	28 x 60
112	M	4	70	4	70	2,2	70	1,5	70	28 x 60	28 x 60
132	S	5,5	70	5,5	70	3	70	2,2	70	38 x 80	38 x 80
132	S	7,5	70	-	-	-	-	-	-	38 x 80	38 x 80
132	M	-	-	7,5	85	4	70	3	70	38 x 80	38 x 80
132	M	-	-	-	-	5,5	85	-	-	38 x 80	38 x 80
160	M	11	100	11	100	7,5	100	4	100	42 x 110	42 x 110

Continuation see next page



Size	Engine	kW		kW		kW		kW		Cyl. shaft end Ø x L by rotary speed of	
		n= 3.000 min ⁻¹	Coupling size	n= 1.500 min ⁻¹	Coupling size	n= 1.000 min ⁻¹	Coupling size	n= 750 min ⁻¹	Coupling size	= 3000 min ⁻¹	≤ 3000 min ⁻¹
160	M	15	100	-	-	-	-	5,5	100	42 x 110	42 x 110
160	L	18,5	100	15	100	11	125	7,5	100	42 x 110	42 x 110
180	M	22	125	18,5	125	-	-	-	-	48 x 110	48 x 110
180	L	-	-	22	125	15	125	11	125	48 x 110	48 x 110
200	L	30	125	30	125	18,5	125	15	125	55 x 110	55 x 110
200	L	37	125	-	-	22	145	-	-	55 x 110	55 x 110
225	S	-	-	37	145	-	-	18,5	145	55 x 110	60 x 140
225	M	45	125	45	145	30	145	22	145	55 x 110	60 x 140
250	M	55	145	55	170	37	170	30	170	60 x 140	65 x 140
280	S	75	145	75	170	45	170	37	170	65 x 140	75 x 140
280	M	90	145	90	200	55	200	45	200	65 x 140	75 x 140
315	S	110	170	110	200	75	200	55	200	65 x 140	80 x 170
315	M	132	170	132	200	90	230	75	230	65 x 140	80 x 170
315	L	160	200	160	230	110	230	90	230	65 x 140	80 x 170
315	L	200	200	200	230	132	230	110	260	65 x 140	80 x 170
315	L	-	-	-	-	160	260	132	260	65 x 140	80 x 170
315	-	250	200	250	260	200	260	160	260	65 x 140	85 x 170
315	-	315	230	315	260	250	300	200	300	65 x 140	85 x 170
355	-	355	230	355	300	315	360	250	360	75 x 140	95 x 170
355	-	400	230	400	300	400	360	315	360	75 x 140	95 x 170
355	-	500	230	500	360	-	-	-	-	75 x 140	95 x 170
400	-	560	260	560	360	450	360	355	360	80 x 170	110 x 210
400	-	630	260	630	360	500	360	400	400	80 x 170	110 x 210
400	-	710	260	710	360	560	400	450	400	80 x 170	110 x 210
450	-	800	-	800	400	630	400	500	400	90 x 170	120 x 210
450	-	900	-	900	400	710	400	560	-	90 x 170	120 x 210
450	-	1000	-	1000	400	800	-	630	-	90 x 170	120 x 210

The allocation of the couplings takes place based on the type RINGFEDER® TNS S-St – VkR and takes into account a uniform torque at the operating point (minimum operating factor 1.25) with

low variation and slight shocks and is valid up to an ambient temperature of +30 °C.

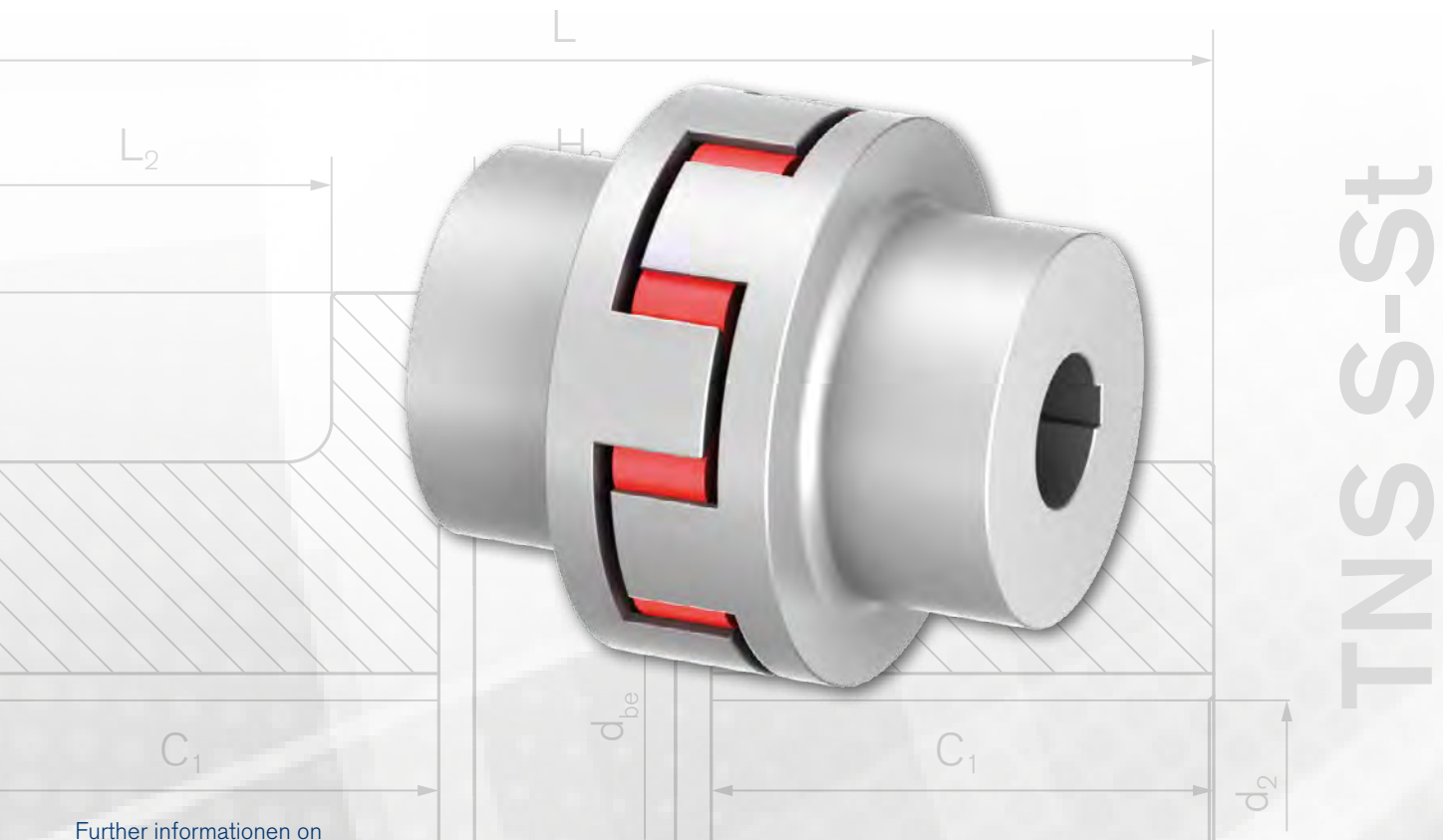

TNS S-St

Further information on
RINGFEDER® TNS S-St
on www.ringfeder.com

Coupling with standard hubs

The **RINGFEDER® TNS S-St** is a torsionally elastic and puncture-proof jaw coupling. It balances out angular, radial and axial shaft offset within determined tolerances. The coupling transmits the torque via pre-compressed, elastic buffers in synthetic rubber (Pb) or polyurethane (Vk), in standard VkR, that are connected to one another to an intermediate ring. The elastic intermediate ring can damp impacts and torsional vibrations and is oil resistant. The coupling can be used in any direction of rotation and installation position.

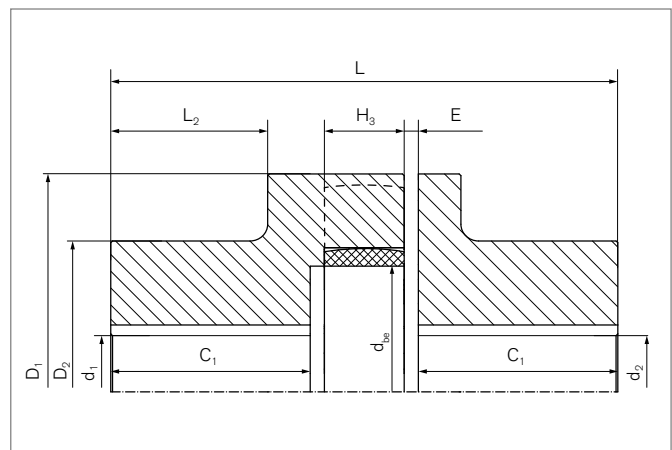

Characteristics

- The intermediate ring can be replaced after shifting a shaft with fitted hub.
- Torsionally flexible, compensate for angular, radial and axial shaft offset
- Optimisation of the vibration damping with different hardness levels of the intermediate ring, usable from -30 °C to $+100\text{ °C}$.
- Standard material for intermediate ring: VkR
- Compact design because of pre-compressed intermediate rings
- Outer diameter up to 400 mm, Bohrung bis max. 160 mm
- Torques up to $T_{KN} = 13350\text{ Nm}$ / $T_{Kmax} = 40050\text{ Nm}$

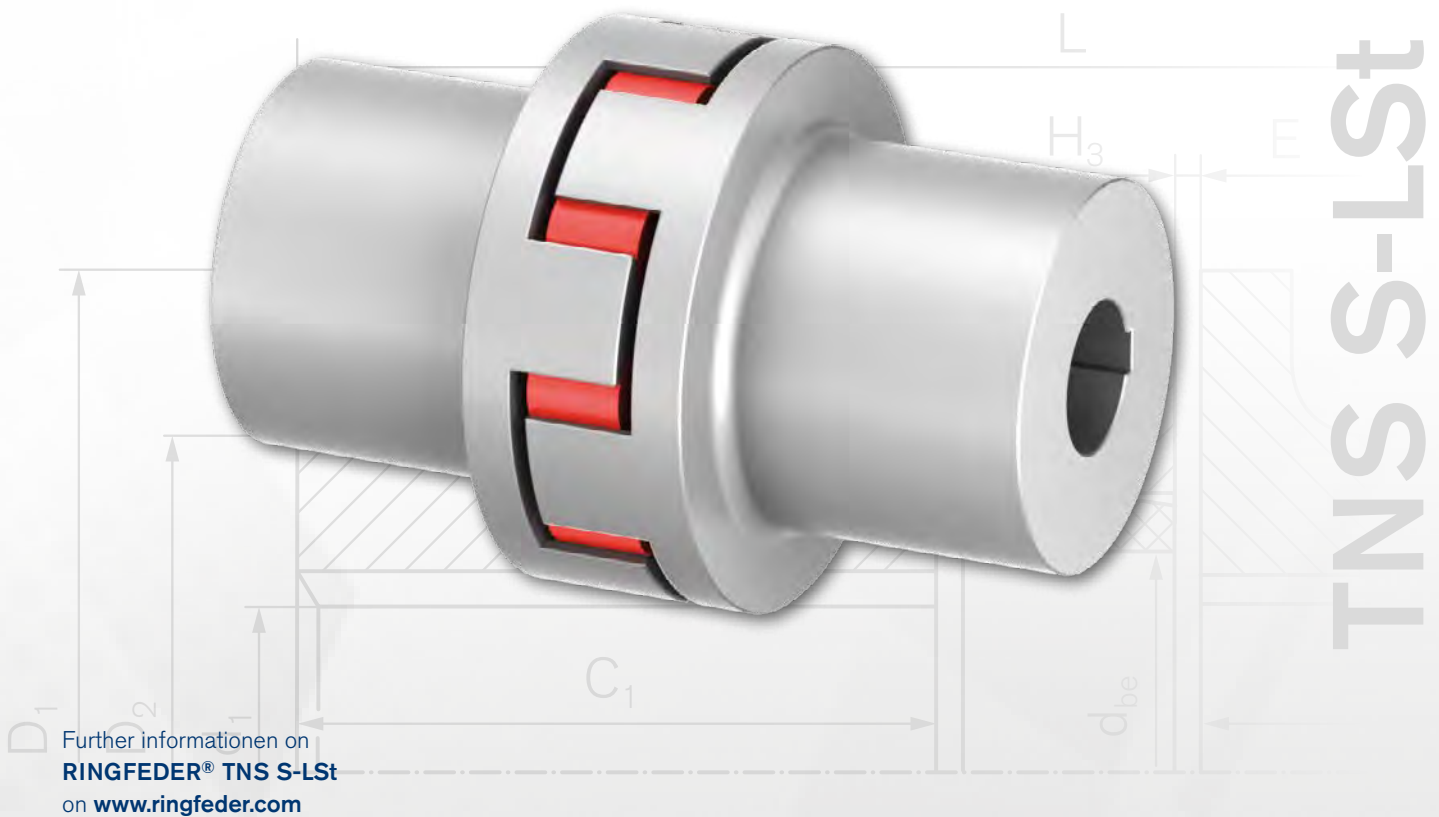

Coupling with extended hubs

The RINGFEDER® TNS S-LSt is a torsionally elastic and puncture-proof jaw coupling with extended hubs. It balances out angular, radial and axial shaft offset within determined tolerances. The coupling transmits the torque via pre-compressed, elastic buffers in synthetic rubber (Pb) or polyurethane (Vk), in standard VkR, that are connected to one another to an intermediate ring. The elastic intermediate ring can damp impacts and torsional vibrations and is oil resistant. The coupling can be used in any direction of rotation and installation position.

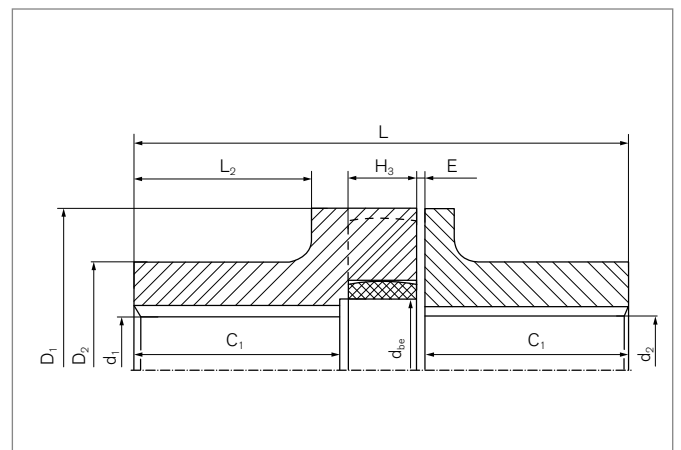

Characteristics

- The intermediate ring can be replaced after shifting a shaft with fitted hub.
- Torsionally flexible, compensate for angular, radial and axial shaft offset
- Optimisation of the vibration damping with different hardness levels of the intermediate ring, usable from -30 °C to $+100\text{ °C}$.
- Standard material for intermediate ring: VkR
- Compact design because of pre-compressed intermediate rings
- Outer diameter up to 400 mm, Bohrung bis max. 160 mm
- Torques up to $T_{KN} = 13350\text{ Nm}$ / $T_{Kmax} = 40050\text{ Nm}$

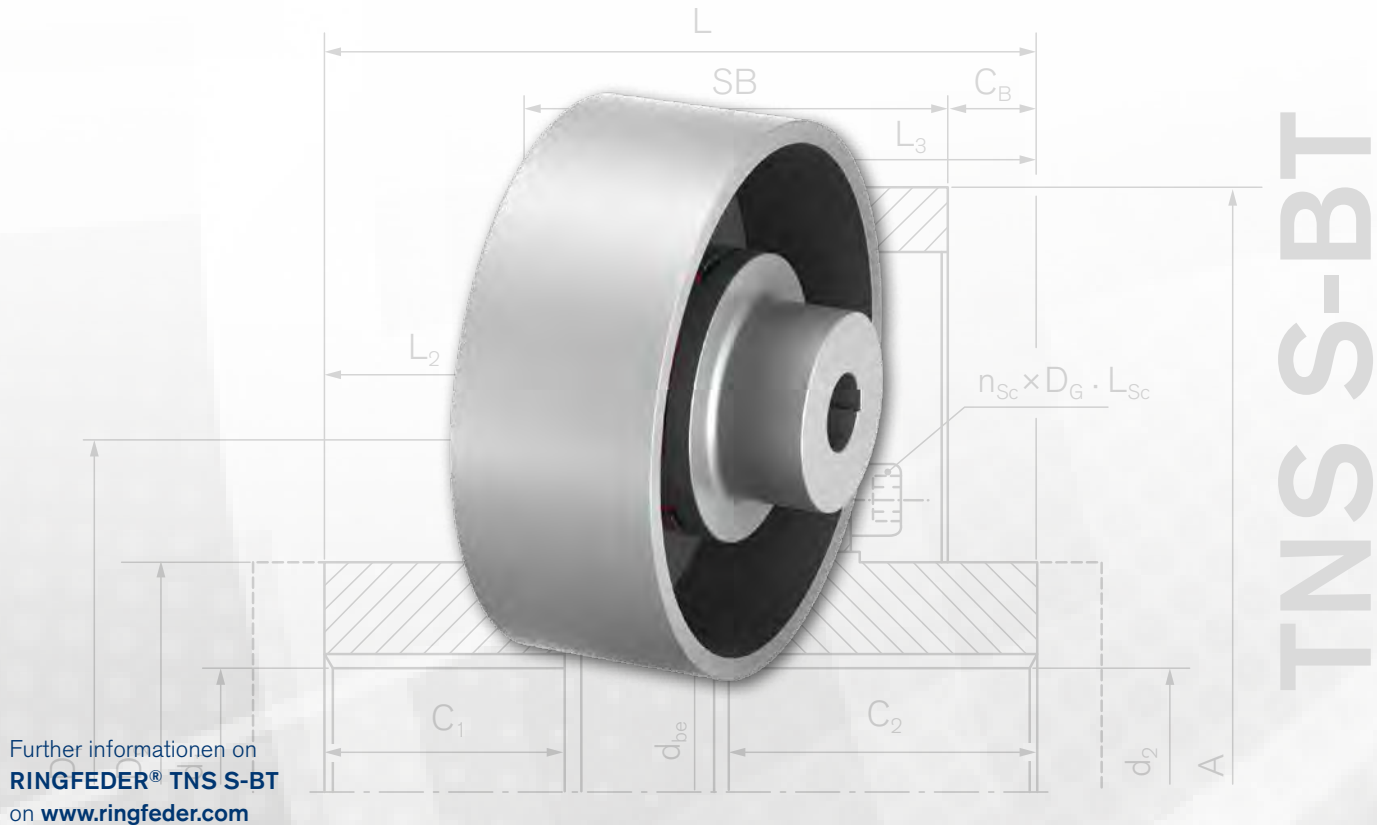

TNS S-BT

Coupling with standard hub and brake drum

The RINGFEDER® TNS S-BT is a torsionally elastic and puncture-proof jaw coupling with attached brake drum. It balances out angular, radial and axial shaft offset within determined tolerances. The coupling transmits the torque via pre-compressed, elastic buffers in synthetic rubber (Pb) or polyurethane (Vk), in standard VkR, that are connected to one another to an intermediate ring. The elastic intermediate ring can damp impacts and torsional vibrations and is oil resistant. The coupling can be used in any direction of rotation and installation position. The brake drum should be connected to the load side.

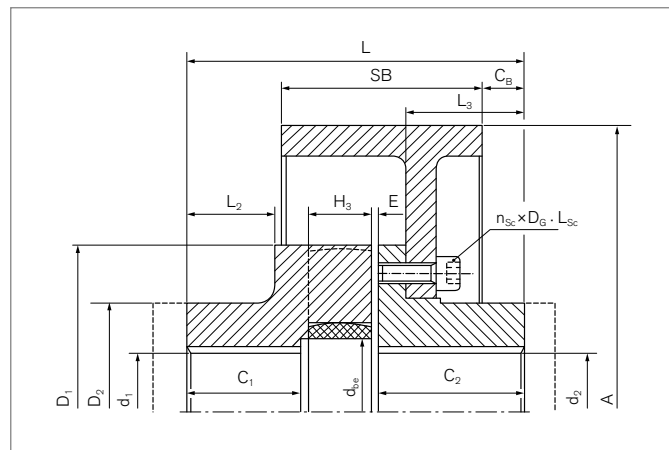

Characteristics

- The intermediate ring can be replaced after shifting a shaft with fitted hub.
- Torsionally flexible, compensate for angular, radial and axial shaft offset
- Optimisation of the vibration damping with different hardness levels of the intermediate ring, usable from -30 °C to $+100\text{ °C}$.
- Standard material for intermediate ring: VkR
- Compact design because of pre-compressed intermediate rings
- Outer diameter up to 400 mm, Bohrung bis max. 160 mm
- Torques up to $T_{KN} = 13350\text{ Nm}$ / $T_{Kmax} = 40050\text{ Nm}$

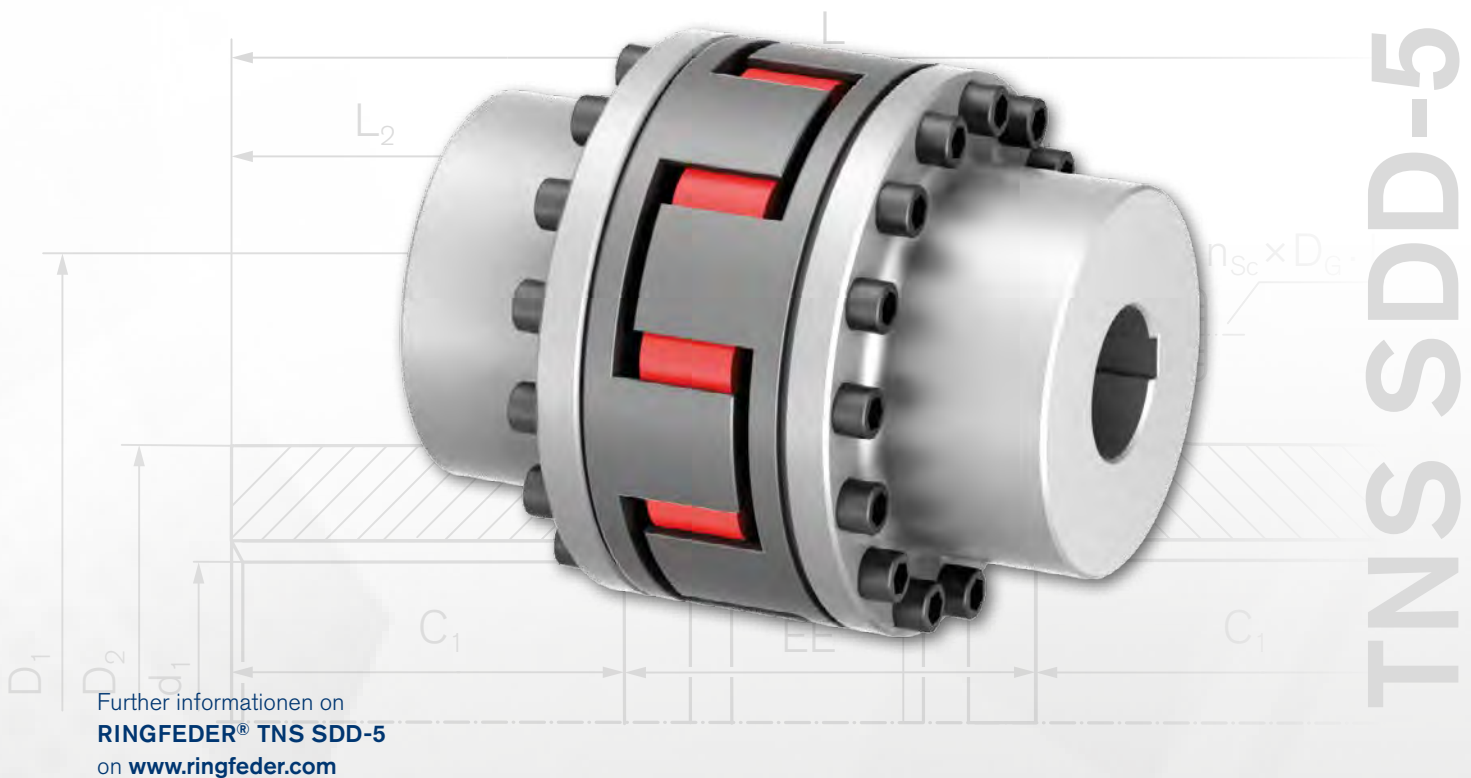

Coupling with detachable claw rings

The RINGFEDER® TNS SDD-5 is a torsionally elastic and puncture-proof multi-part jaw coupling with standard flange hubs and removable jaw rings. It balances out angular, radial and axial shaft offset within determined tolerances. The coupling transmits the torque via pre-compressed, elastic buffers in synthetic rubber (Pb) or polyurethane (Vk), in standard VkR, that are connected to one another to an intermediate ring. The elastic intermediate ring can damp impacts and torsional vibrations and is oil resistant. The coupling can be used in any direction of rotation and installation position. Radial installation and removal of the jaw rings are possible because both coupling halves are in two sections. Thus it is possible to change the elastic intermediate ring without moving the aggregates. When the jaw rings have been

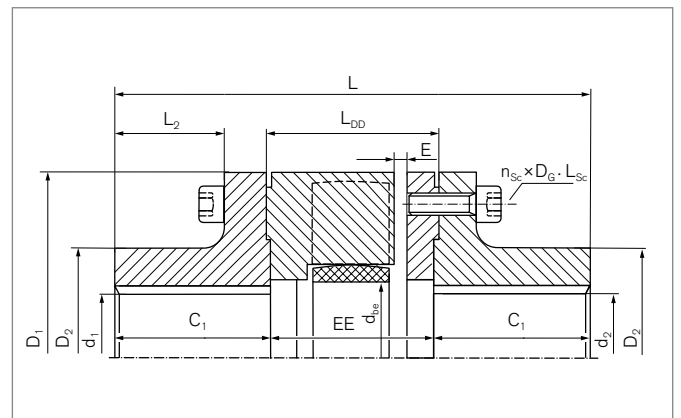

dismounted it is also simple to carry out a check on the rotational direction of the drive.

Characteristics

- The intermediate ring can be exchanged following removal of the jaw rings without moving a shaft.
- Rotational direction can be checked when jaw rings are dismantled
- Simplified assembly and maintenance of the drive line through improved accessibility
- Optimisation of the vibration damping with different hardness levels of the intermediate ring, usable from -30 °C to $+100\text{ °C}$.
- Standard material for intermediate ring: VkR
- Compact design because of pre-compressed intermediate rings
- Outer diameter up to 400 mm, Bohrung bis max. 160 mm
- Torques up to $T_{KN} = 13350\text{ Nm}$ / $T_{Kmax} = 40050\text{ Nm}$

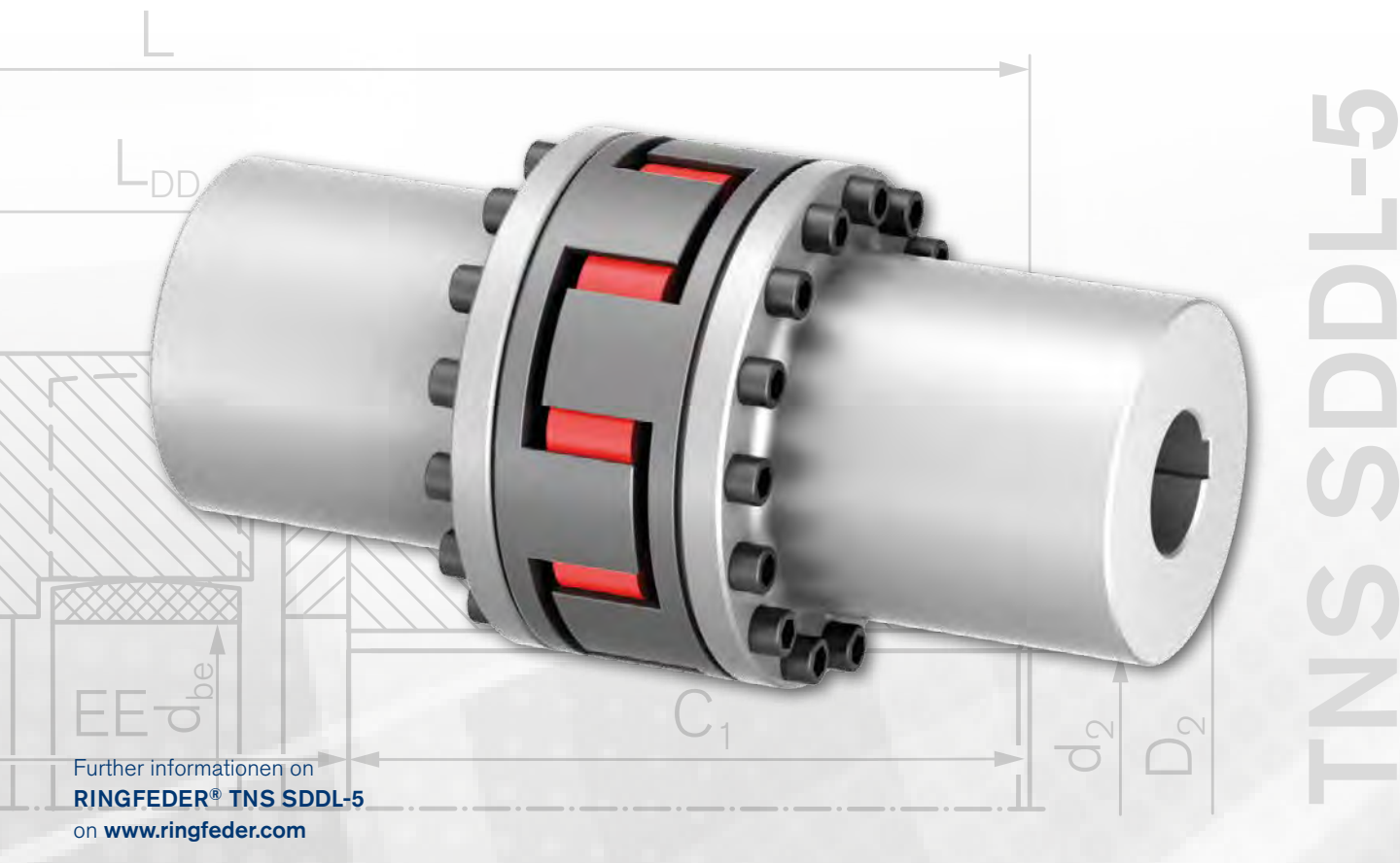

Coupling with detachable claw rings and long flange hubs

The RINGFEDER® TNS SDDL-5 is a torsionally elastic and puncture-proof multi-part jaw coupling with long flange hubs and removable jaw rings. It balances out angular, radial and axial shaft offset within determined tolerances. The coupling transmits the torque via pre-compressed, elastic buffers in synthetic rubber (Pb) or polyurethane (Vk), in standard VkR, that are connected to one another to an intermediate ring. The elastic intermediate ring can damp impacts and torsional vibrations and is oil resistant. The coupling can be used in any direction of rotation and installation position. Radial installation and removal of the jaw rings are possible because both coupling halves are in two sections. Thus it is possible to change the elastic intermediate ring without moving the aggregates. When the jaw rings have been dismantled it is also simple to carry out a check on the rotational direction of the drive.

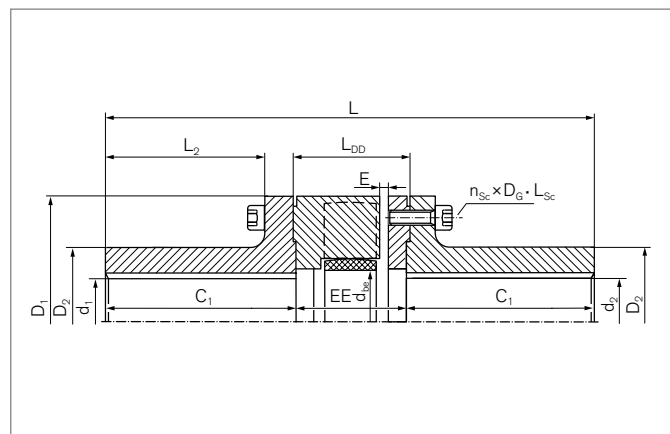

Characteristics

- The intermediate ring can be exchanged following removal of the jaw rings without moving a shaft.
- Rotational direction can be checked when jaw rings are dismantled
- Simplified assembly and maintenance of the drive line through improved accessibility
- Optimisation of the vibration damping with different hardness levels of the intermediate ring, usable from -30 °C to $+100\text{ °C}$.
- Standard material for intermediate ring: VkR
- Compact design because of pre-compressed intermediate rings
- Outer diameter up to 400 mm, Bohrung bis max. 160 mm
- Torques up to $T_{KN} = 13350\text{ Nm}$ / $T_{Kmax} = 40050\text{ Nm}$

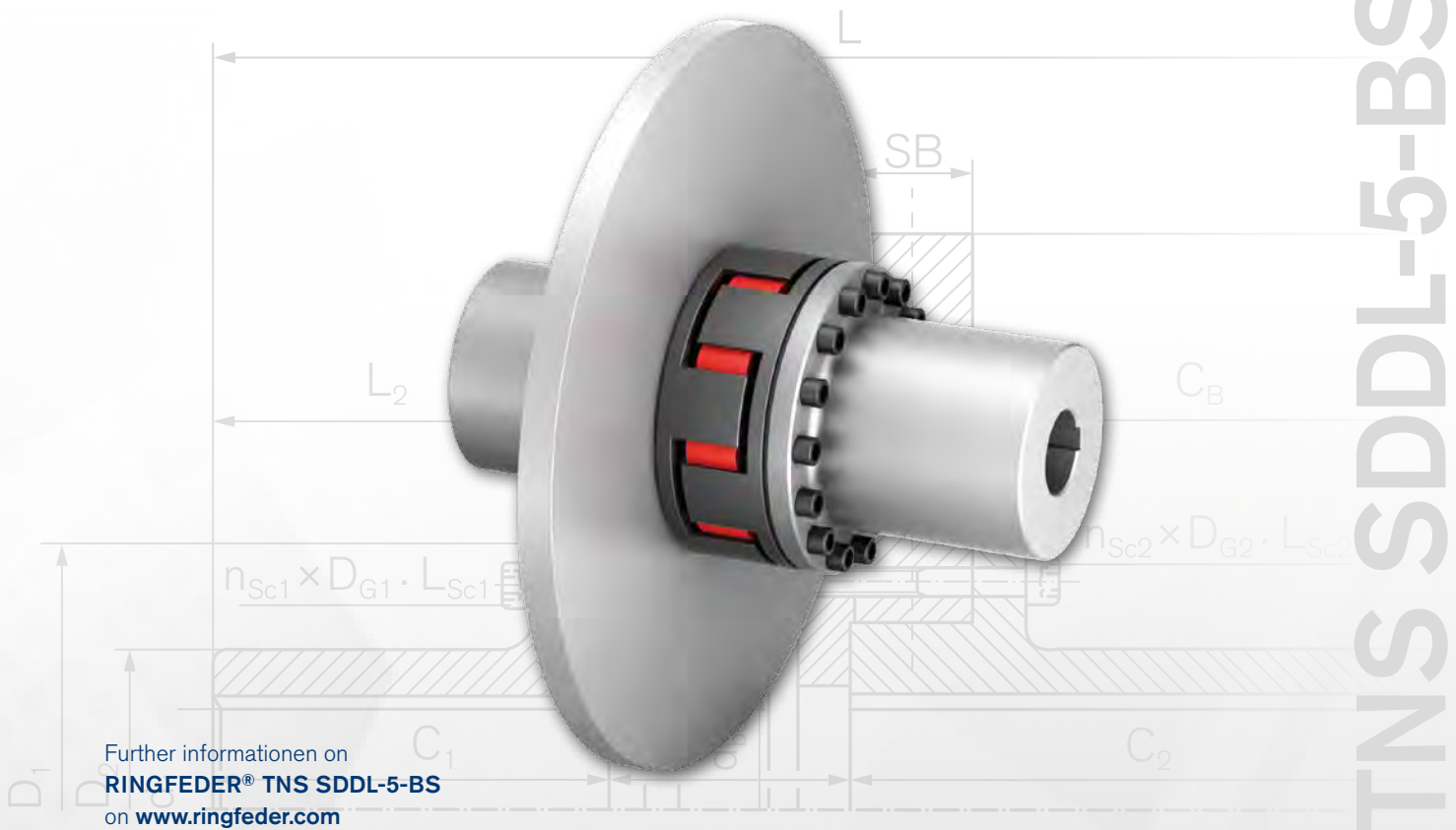

Further information on
RINGFEDER® TNS SDDL-5-BS
on www.ringfeder.com

TNS SDDL-5-BS

Coupling with detachable claw rings, long hubs and brake disc

The RINGFEDER® TNS SDDL-5-BS is a torsionally elastic and puncture-proof multi-part jaw coupling with a brake disc and removable jaw rings. The coupling transmits the torque via pre-compressed, elastic buffers in polyurethane (Vk) in standard Vk60D, that are connected to one another to an intermediate ring. The elastic intermediate ring can damp impacts and torsional vibrations and is oil resistant. Radial installation and removal of the jaw rings and then the brake disc are possible because both coupling halves are in two sections. Thus it is possible to exchange the elastic intermediate ring without moving the aggregates. When the jaw rings and brake disc have been dismantled it is also simple to carry out a check on the rotational direction of the drive.

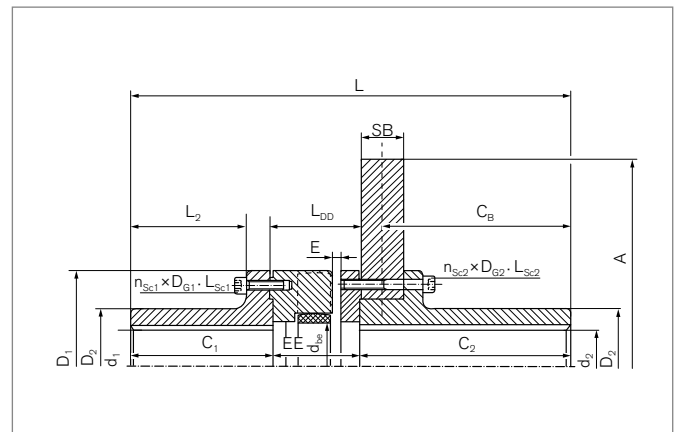

Characteristics

- The intermediate ring can be exchanged following removal of the jaw rings without moving a shaft.
- Rotational direction can be checked when jaw rings are dismantled
- Simplified assembly and maintenance of the drive line through improved accessibility
- Optimisation of the vibration damping with different hardness levels of the intermediate ring, usable from -30 °C to $+100\text{ °C}$.
- Standard material for intermediate ring: Vk60D
- Outer diameter up to 400 mm, Bohrung bis max. 160 mm
- Torques up to $T_{KN} = 13350\text{ Nm}$ / $T_{Kmax} = 40050\text{ Nm}$

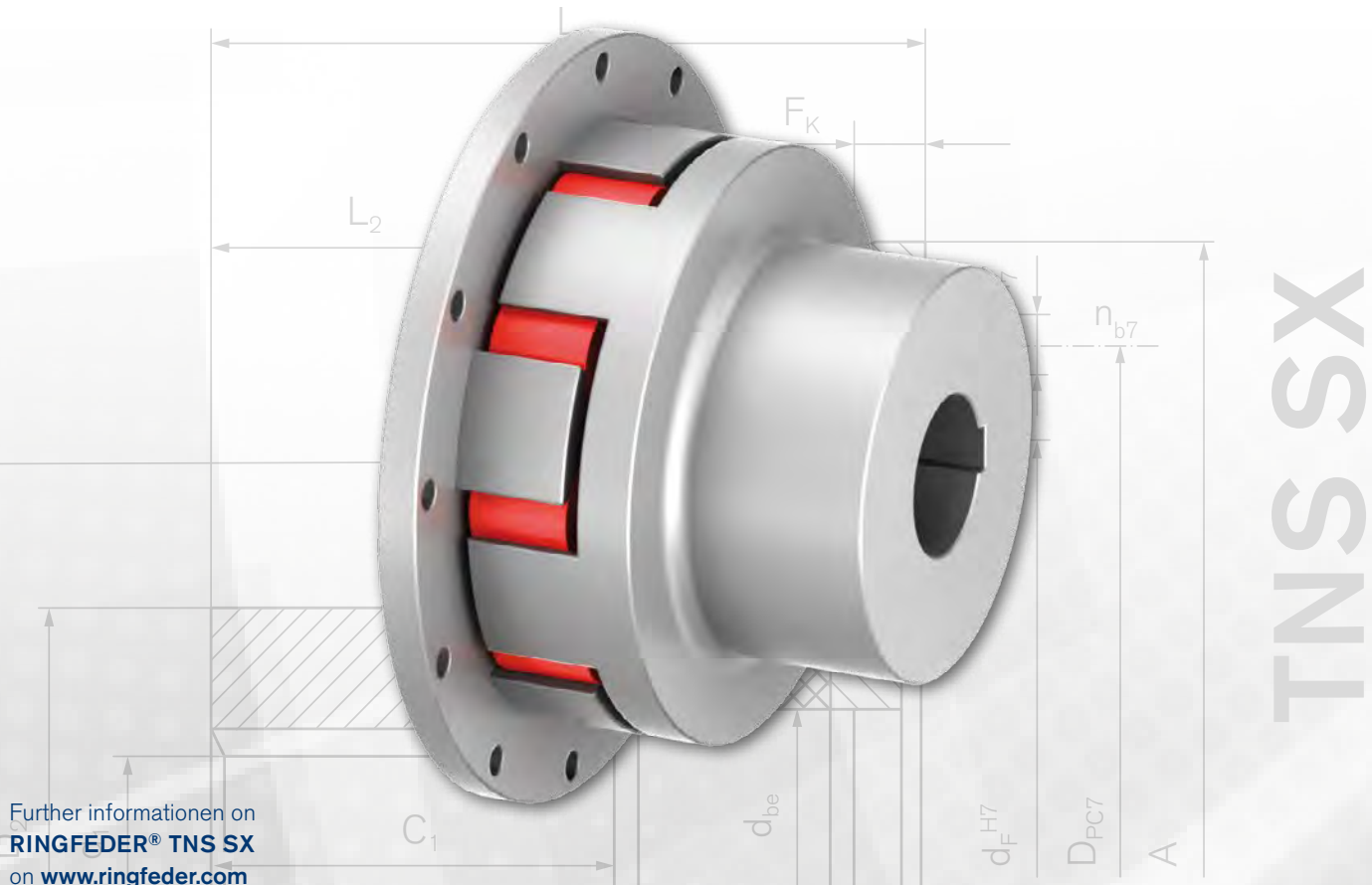

Further information on
RINGFEDER® TNS SX
on www.ringfeder.com

Coupling with standard hub and claw flange

The RINGFEDER® TNS SX is a torsionally elastic and puncture-proof jaw coupling that is especially suited to hydrodynamic turbo couplings. It balances out angular, radial and axial shaft offset within determined tolerances. The coupling transmits the torque via pre-compressed, elastic buffers in synthetic rubber (Pb) or polyurethane (Vk), in standard Perbunan Pb82, that are connected to one another to an intermediate ring. The elastic intermediate ring can damp impacts and torsional vibrations and is oil resistant. The coupling can be used in any direction of rotation and installation position.

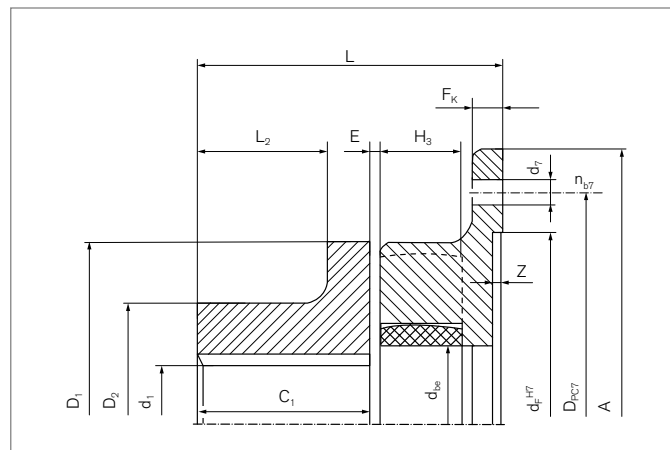

Characteristics

- Standardised flange connection in aluminium
- The intermediate ring can be exchanged with a mounted hub when one shaft has been moved.
- Torsionally elastic and puncture-proof, balances out angular, radial and axial shaft offset
- Optimisation of the vibration damping with different hardness levels of the intermediate ring, usable from -30 °C to $+100\text{ °C}$.
- Standard material for intermediate ring: Pb82
- Outer diameter up to 400 mm, Bohrung bis max. 160 mm
- Torques up to $T_{KN} = 4750\text{ Nm}$ / $T_{Kmax} = 14250\text{ Nm}$

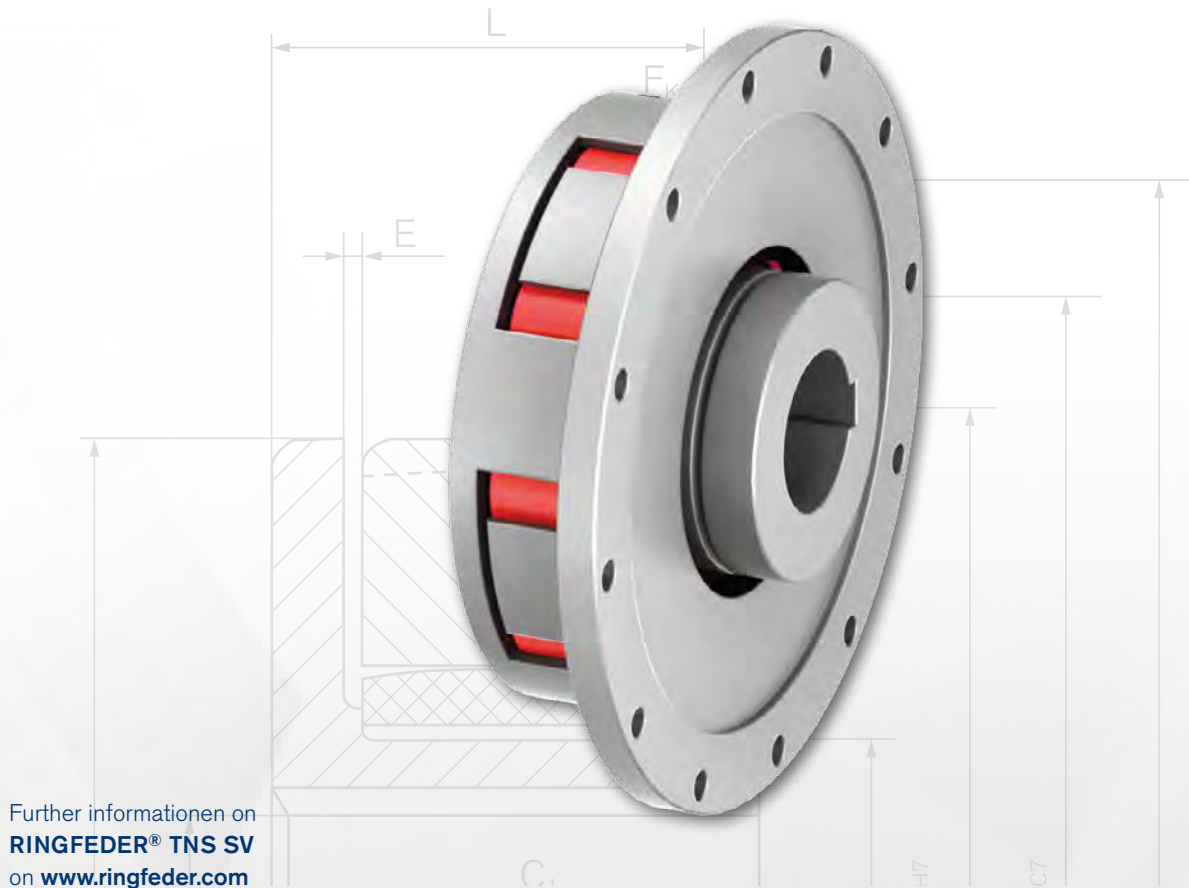

Further information on
RINGFEDER® TNS SV
on www.ringfeder.com

Coupling with inner hub and claw flange

The RINGFEDER® TNS SV is a torsionally elastic, puncture-proof and compact jaw coupling that is especially suited to hydrodynamic turbo couplings. It balances out angular, radial and axial shaft offset within determined tolerances. The coupling transmits the torque via pre-compressed, elastic buffers in synthetic rubber (Pb) or polyurethane (Vk), in standard Perbunan Pb82, that are connected to one another to an intermediate ring. The elastic intermediate ring can damp impacts and torsional vibrations and is oil resistant. The coupling can be used in any direction of rotation and installation position.

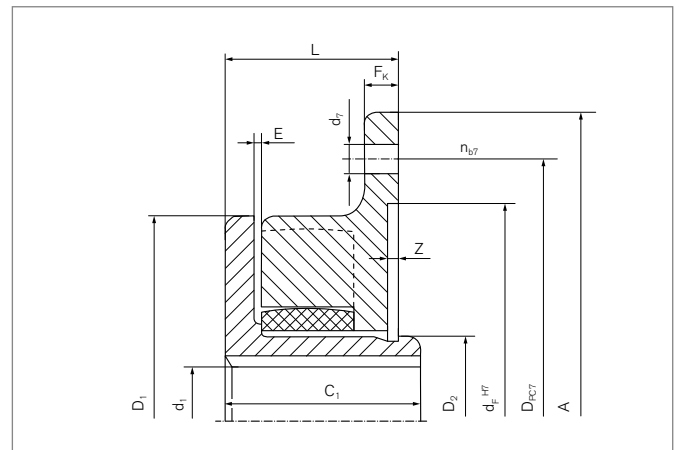

Characteristics

- Standardised flange connection in aluminium
- Axially compact through internal coupling hub
- The intermediate ring can be exchanged with a mounted hub when one shaft has been moved.
- Torsionally elastic and puncture-proof, balances out angular, radial and axial shaft offset
- Optimisation of the vibration damping with different hardness levels of the intermediate ring, usable from -30 °C to $+100\text{ °C}$.
- Standard material for intermediate ring: Pb82
- Outer diameter up to 400 mm, Bohrung bis max. 160 mm
- Torques up to $T_{KN} = 4750\text{ Nm}$ / $T_{Kmax} = 14250\text{ Nm}$

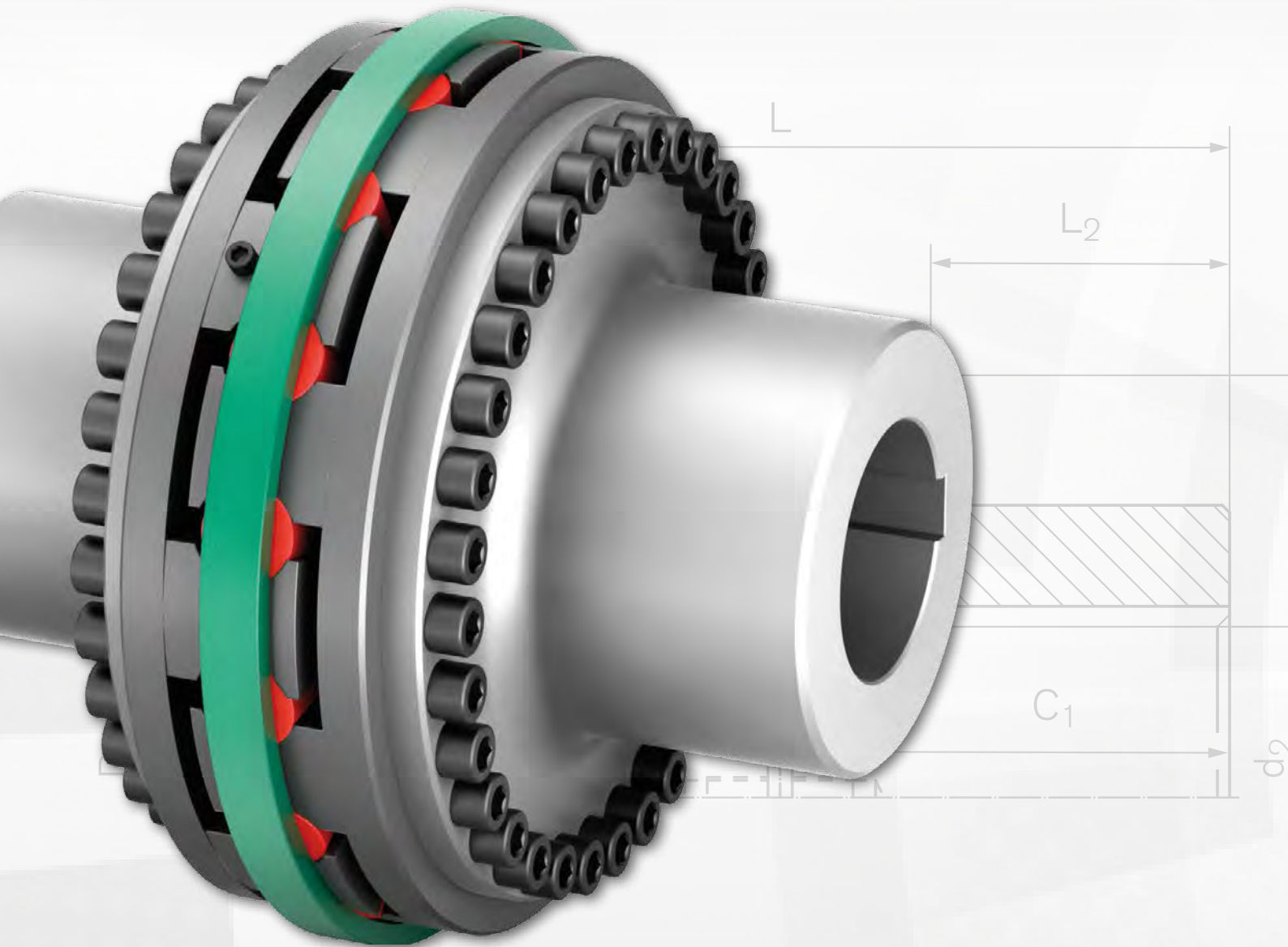

Elastomer Jaw Couplings RINGFEDER® TNB

RINGFEDER® TNB jaw couplings are puncture-proof, elastic heavy load couplings. They are often used on the output shaft of the gearbox in order to damp process-related impacts and to absorb the dynamic effects of the acceleration of heavy masses. Used in drives for ore production and processing in mining and construction engineering, in cement works, in material handling and also in offshore technology.

Characteristics · Advantages

- Torsionally flexible and damping of torsional vibrations
- High breakage resistance through stable jaw design
- Many variations with modular design
- Radially accessible individual buffers reduce assembly and maintenance work
- Nom. torques: 1000–260000 Nm

Basic informationen

The technical data tables for the couplings types supplied in this catalogue include for one part design hubs hard VkW buffer and for multi-part design hubs middle hard VκR buffers. The soft Pb82 buffers can be used in each type considering the lower torque capability.

The higher the hardness of the elastic buffers, the higher the torque transmission capability of the coupling and, as a result, the higher is the torsion spring stiffness. The rated torque T_{KN} listed in the tables is the torque that the coupling is capable of transmitting

continuously. The maximum torque T_{Kmax} is the torque that the coupling is able to transmit for a short time up to 10^5 times, e.g. during start-up.

Torsional vibration analyses (TVA) are performed by specialists to optimize the drive line. To this purpose, a detailed description of the oscillatory system is required, including the mechanical arrangement (spring-mass system) as well as the plant-related excitation functions. The specific coupling data such as stiffness, damping and mass moments of inertia will be supplied on request.

Size	Speed min^{-1} n_{max}	Nm		Torque with following buffer Nm		Nm	
		Pb82		VκR		VκW	
		T_{KN}	T_{Kmax}	T_{KN}	T_{Kmax}	T_{KN}	T_{Kmax}
240	4100	1000	3000	2500	7500	-	-
300	3300	2000	6000	6000	18000	8600	25800
350	2800	3400	10200	10500	31500	15000	45000
400	2450	5050	15150	16000	48000	23000	69000
450	2200	6850	20550	21000	63000	31000	93000
500	2000	10300	30900	28500	85500	41200	123600
550	1800	13200	39600	45000	135000	66000	198000
600	1650	16500	49500	55000	165000	80000	240000
650	1500	19700	59100	65000	195000	94000	282000
700	1400	26700	80100	90000	270000	130000	390000
800	1200	39000	117000	125000	375000	180000	540000
900	1100	54000	162000	180000	540000	260000	780000

T_{KN} = Nominal torque of coupling

T_{Kmax} = Max. torque of the coupling by one part design

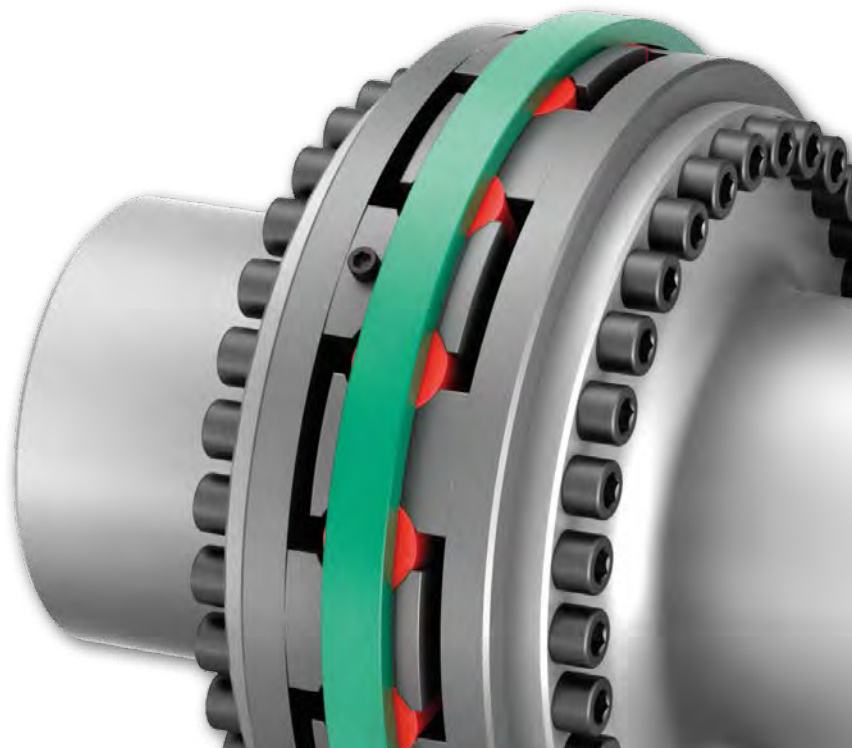

Replacement of elastic buffers without axial movement of the coupled machines. After removing the cheese head screws the retaining ring can axial shift and the buffers are free changeable each by each.

The central section can be radially removed as required or can be released on one side. As a result the facilitates assembly of heavy weight drive components. As well the direction of rotation of the electric motor can be checked.

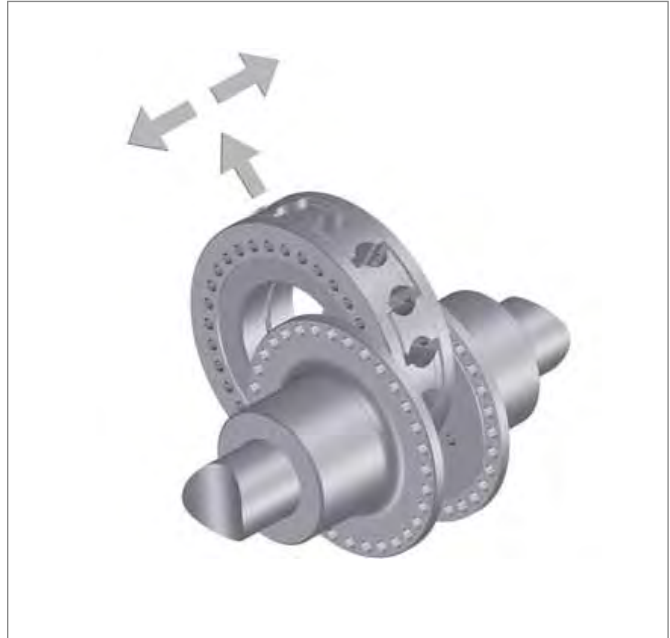
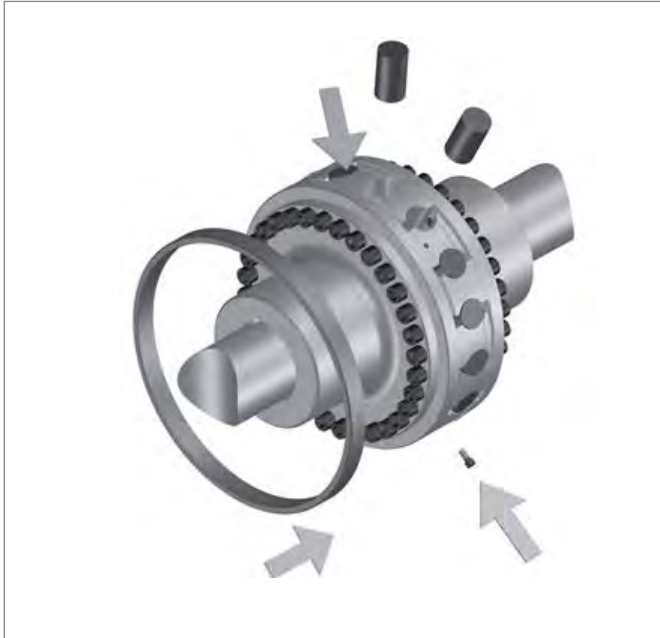

Allocation of the RINGFEDER® TNB couplings to IEC standard motors Protection rating IP 54/IP 55 (intermediate ring VkR)

Size	Engine	kW		kW		kW		kW		Cyl. shaft end Ø x L by rotary speed of	
		n= 3.000 min ⁻¹	Coupling size	n= 1.500 min ⁻¹	Coupling size	n= 1.000 min ⁻¹	Coupling size	n= 750 min ⁻¹	Coupling size	= 3000 min ⁻¹	≤ 3000 min ⁻¹
250	M	55	240	55	240	37	240	30	240	65 x 140	75 x 140
280	S	75	240	75	240	45	240	34	240	65 x 140	75 x 140
280	M	90	240	90	240	55	240	45	240	65 x 140	80 x 170
315	S	110	240	110	240	75	240	55	240	65 x 140	80 x 170
315	M	132	240	132	240	90	240	75	240	65 x 141	80 x 170
315	L	160	240	160	240	110	240	90	240	65 x 142	80 x 170
315	L	200	240	200	240	132	240	110	240	65 x 143	80 x 170
315	L	-	240	-	240	160	240	132	240	65 x 144	80 x 170
315	-	250	240	250	240	200	240	160	300	65 x 145	85 x 170
315	-	315	240	315	300	250	300	200	300	65 x 146	85 x 170
355	-	355	240	355	300	315	300	250	300	75 x 140	95 x 170
355	-	400	240	400	240	400	300	315	300	75 x 140	95 x 170
355	-	500	240	500	240	-	-	-	-	75 x 140	95 x 170
400	-	560	240	560	240	450	300	355	300	80 x 170	110 x 210
400	-	630	300	630	240	500	350	400	350	70 x 170	110 x 210
400	-	710	300	710	240	560	350	450	350	70 x 170	110 x 210
450	-	800	300	800	350	630	350	500	350	90 x 170	120 x 210
450	-	900	300	900	350	710	350	560	350	90 x 170	120 x 210
450	-	1000	300	1000	350	800	350	630	350	90 x 170	120 x 210

The allocation of the couplings is based on the type RINGFEDER® TNB with VkR buffer and takes into account a uniform torque at the operating point (minimum operating factor 1.25) with low

variation and slight shocks and is valid up to an ambient temperature of +30 °C.



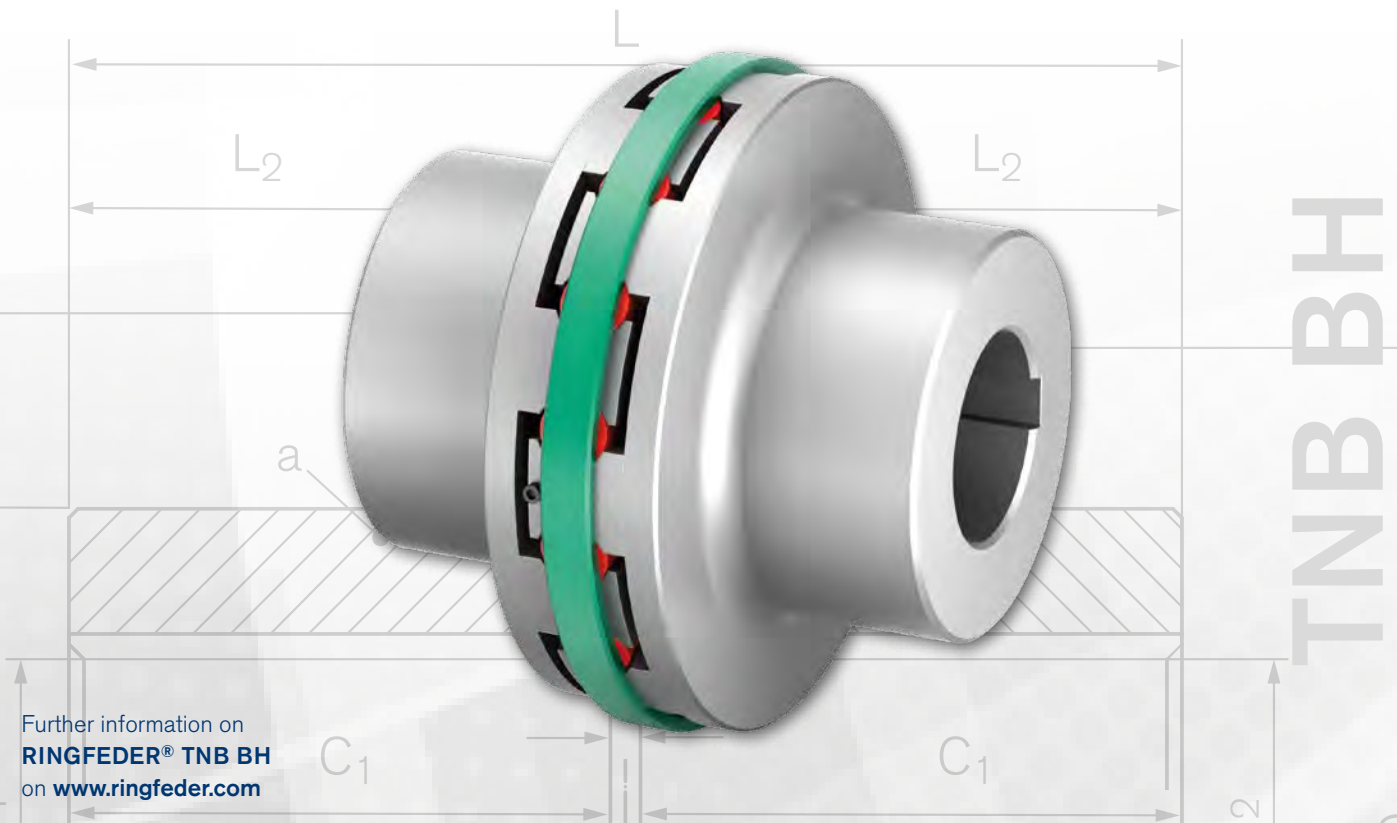

Combination of one-part design coupling hubs with Vkw buffer for highest torque transmission

The RINGFEDER® TNB BH coupling is a torsionally elastic and puncture-proof jaw coupling. It balances out angular, radial and axial shaft offset within determined tolerances. The coupling transmits the torque via pre-compressed and radially freely accessible elastic buffers in synthetic rubber (Perbunan; Pb) or polyurethane (Vulkollan; Vkw), in standard Vkw. The elastic buffers can damp impacts and torsional vibrations and are oil resistant. The coupling can be used in any direction of rotation and installation position.

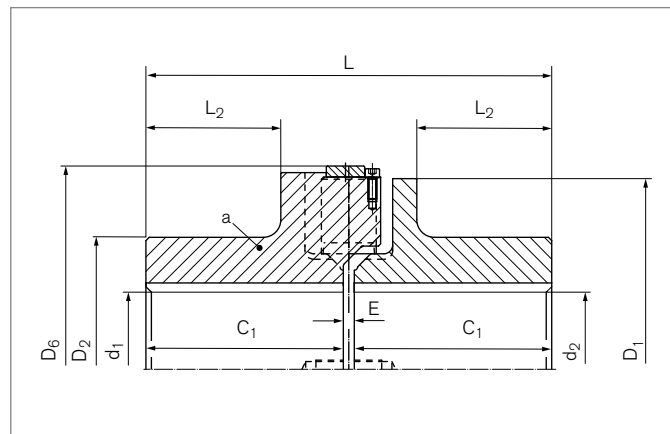

Characteristics

- Radially accessible individual buffers reduce assembly and maintenance work
- Torsionally elastic and puncture-proof, balances out angular, radial and axial shaft offset
- Optimisation of the vibration damping through different buffer hardness levels, usable from -30 °C to +100 °C.
- Maximum torque transmission through single-part coupling hub and Vkw buffer
- Fitted with extraction and transportation bores
- Nominal torques $T_{KN} = 260000 \text{ Nm}$

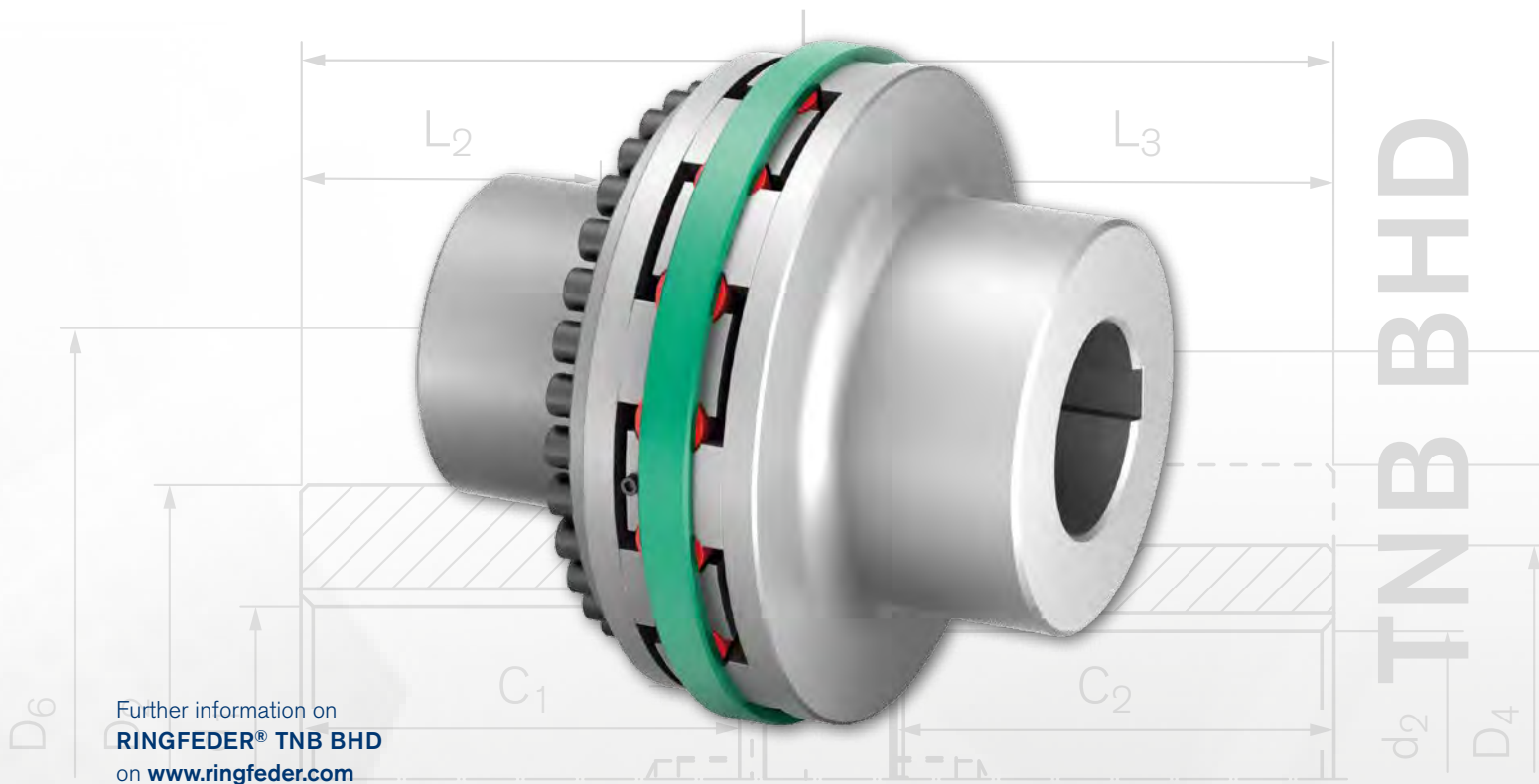

Combination of an one-part design and a multi-part design coupling hub and VkR buffer

The RINGFEDER® TNB BHD coupling is a torsionally elastic and puncture-proof jaw coupling. It balances out angular, radial and axial shaft offset within determined tolerances. The coupling transmits the torque via pre-compressed and radially freely accessible elastic buffers in synthetic rubber (Perbunan; Pb) or polyurethane (Vulkollan; Vk), in standard VkR. The elastic buffers can damp impacts and torsional vibrations and are oil resistant. The coupling can be used in any direction of rotation and installation position. One of the coupling halves is divided into flange hub and jaw ring. When the jaw ring is pulled back the drive line is separated, allowing simple checking of the rotational direction of the drive. This additional interface substantially simplifies the assembly of the drive line.

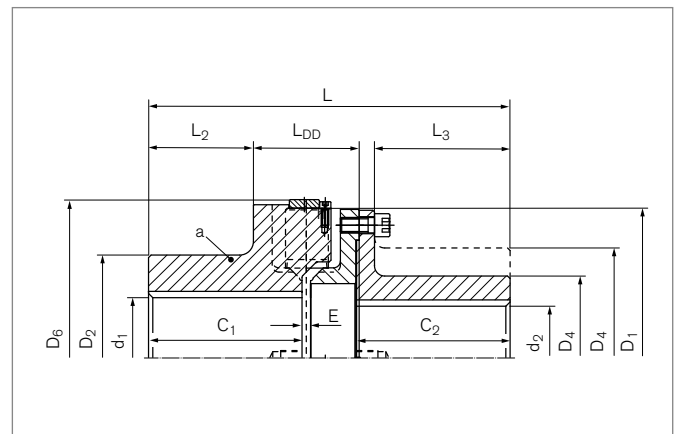

Characteristics

- Radially accessible individual buffers reduce assembly and maintenance work
- Simplified assembly and rotational direction check through separation of jaw ring and flange hub
- Torsionally elastic and puncture-proof, balances out angular, radial and axial shaft offset
- Optimisation of the vibration damping through different buffer hardness levels, usable from -30 °C to +100 °C.
- Fitted with extraction and transportation bores
- Nominal torques $T_{KN} = 180000 \text{ Nm}$

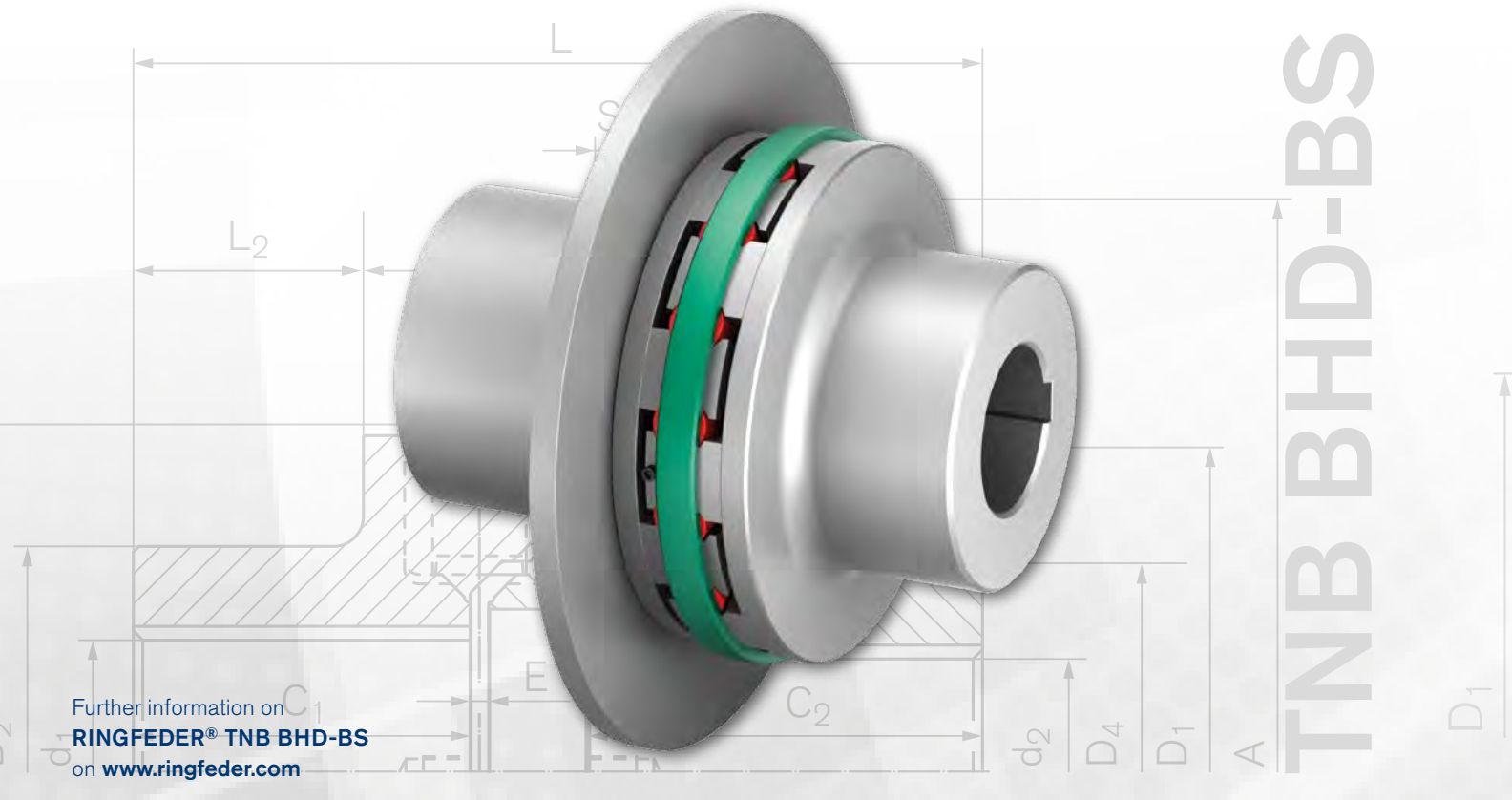

Further information on
RINGFEDER® TNB BHD-BS
on www.ringfeder.com

Combination of an one-part design and a multi-part design coupling hub with brake disc and VkR buffer.

The RINGFEDER® TNB BHD-BS coupling is a torsionally elastic and puncture-proof jaw coupling with a straight brake disc. It balances out angular, radial and axial shaft offset within determined tolerances. The coupling transmits the torque via pre-compressed and radially freely accessible elastic buffers in synthetic rubber (Perbunan; Pb) or polyurethane (Vulkollan; Vk), in standard VkR. The elastic buffers can damp impacts and torsional vibrations and are oil resistant. The coupling can be used in any direction of rotation and installation position. One of the coupling halves is divided into flange hub and jaw ring. When the jaw ring is pulled back the drive line is separated, allowing simple checking of the rotational direction of the drive. This additional interface substantially simplifies the assembly of the drive line.

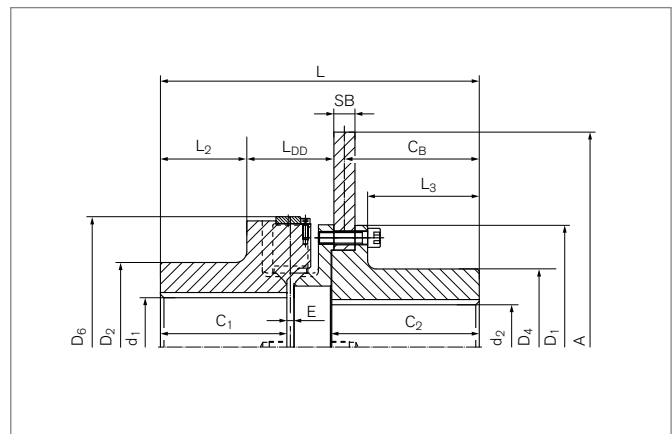

Characteristics

- Radially accessible individual buffers reduce assembly and maintenance work
- Simplified assembly and rotational direction check through separation of jaw ring and flange hub
- Torsionally elastic and puncture-proof, balances out angular, radial and axial shaft offset
- Optimisation of the vibration damping through different buffer hardness levels, usable from -30 °C to +100 °C.
- Fitted with extraction and transportation bores
- Nominal torques $T_{KN} = 180000 \text{ Nm}$

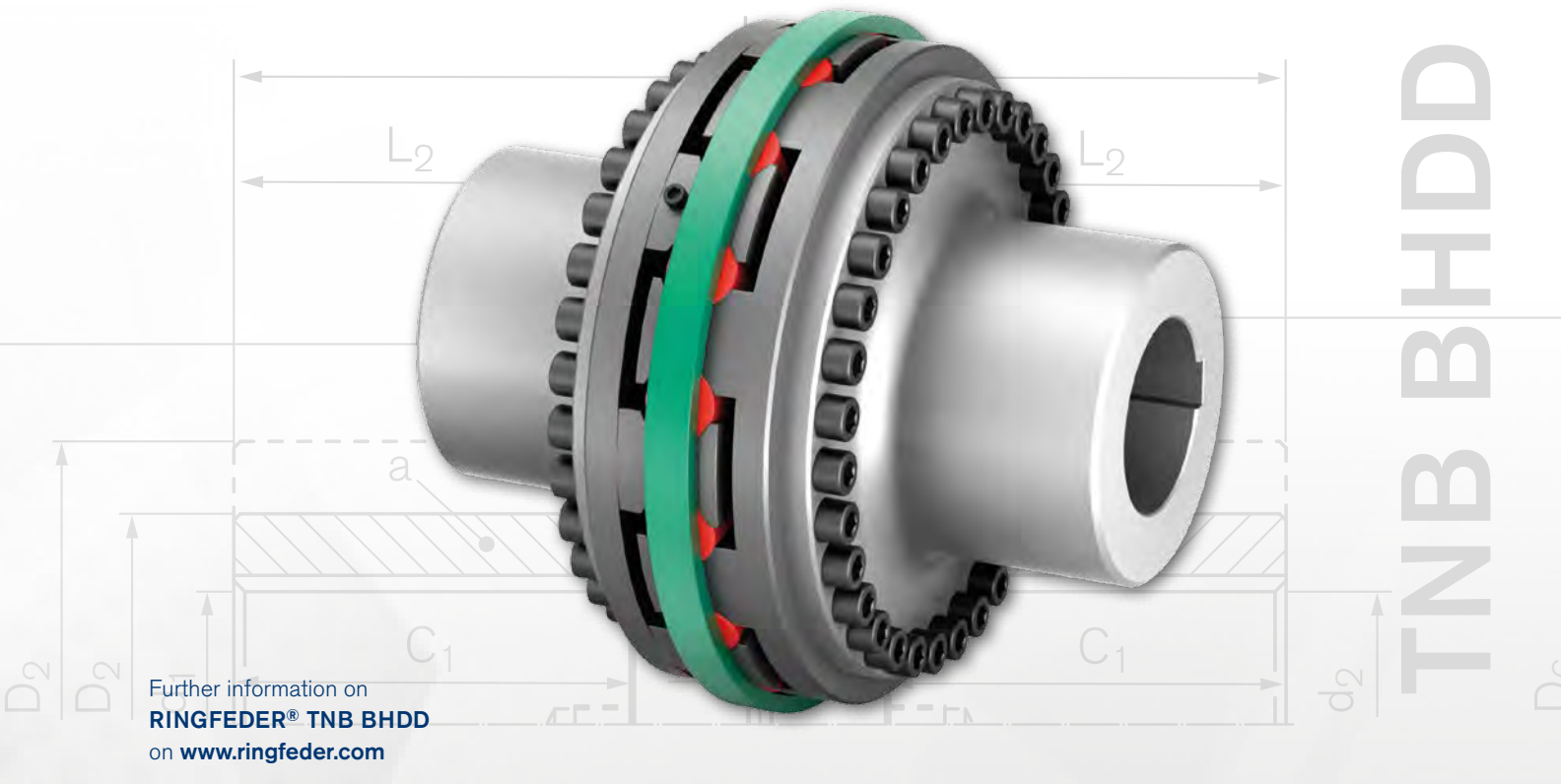

Combination of multi-part design coupling hubs with radially removable central section and VkR buffer

The RINGFEDER® TNB BHDD coupling is a torsionally elastic and puncture-proof jaw coupling with removable central section. It balances out angular, radial and axial shaft offset within determined tolerances. The coupling transmits the torque via pre-compressed and radially freely accessible elastic individual buffers in synthetic rubber (Perbunan; Pb) or polyurethane (Vulkollan; Vk), in standard VkR. The elastic buffers can damp impacts and torsional vibrations and are oil resistant. The coupling can be used in any direction of rotation and installation position. Both coupling halves are divided into flange hub and jaw ring. When the central section is removed the drive line is separated, allowing simple checking of the rotational direction of the drive. This additional free space substantially simplifies the assembly of the drive line.

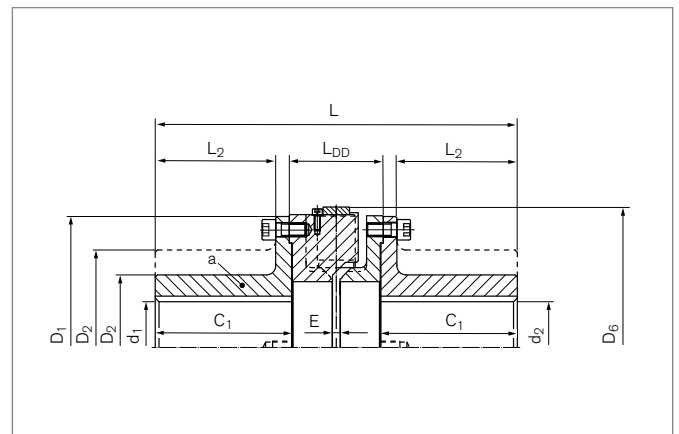

Characteristics

- Radially accessible individual buffers reduce assembly and maintenance work
- Simplified assembly and rotational direction check through separation of jaw ring and flange hub
- Increased assembly space by removing the jaw rings
- Torsionally elastic and puncture-proof, balances out angular, radial and axial shaft offset
- Optimisation of the vibration damping through different buffer hardness levels, usable from -30 °C to +100 °C.
- Fitted with extraction and transportation bores
- Nominal torques $T_{KN} = 180000 \text{ Nm}$

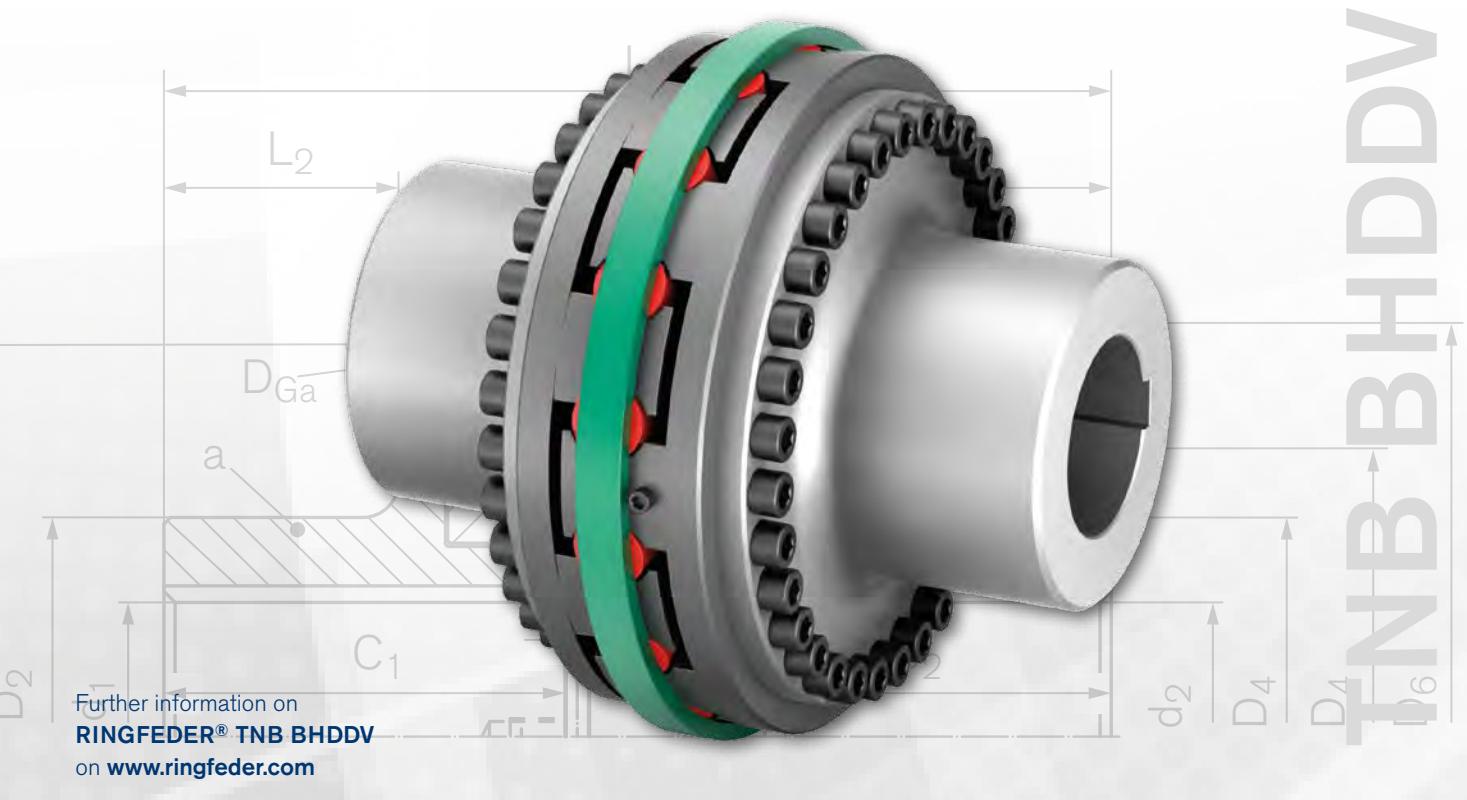

Combination of multi-part design coupling hubs for short shaft distances with VkR buffer

The RINGFEDER® TNB BHDDV coupling is a torsionally elastic and puncture-proof jaw coupling. It balances out angular, radial and axial shaft offset within determined tolerances. The coupling transmits the torque via pre-compressed and radially freely accessible elastic individual buffers in synthetic rubber (Perbunan; Pb) or polyurethane (Vulkollan; Vk), in standard ZZZ. The elastic buffers can damp impacts and torsional vibrations and are oil resistant. The coupling can be used in any direction of rotation and installation position. When the jaw ring is pulled back this allows simple checking of the rotational direction of the drive. This additional interface substantially simplifies the assembly of the drive line.

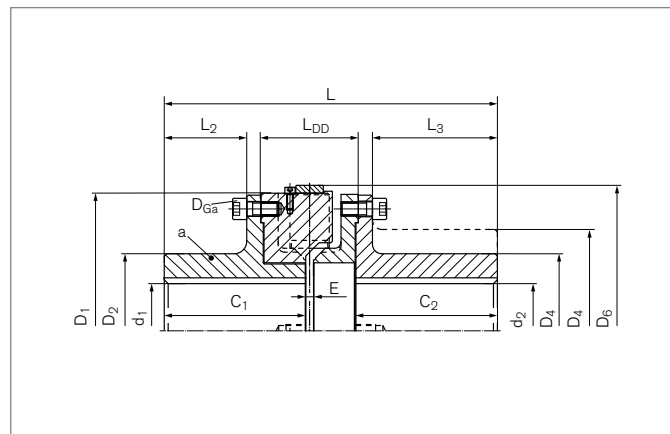

Characteristics

- Radially accessible individual buffers reduce assembly and maintenance work
- Simplified assembly and rotational direction check through separation of jaw ring and flange hub
- Torsionally elastic and puncture-proof, balances out angular, radial and axial shaft offset
- Optimisation of the vibration damping through different buffer hardness levels, usable from -30 °C to +100 °C.
- Fitted with extraction and transportation bores
- Nominal torques $T_{KN} = 180000 \text{ Nm}$

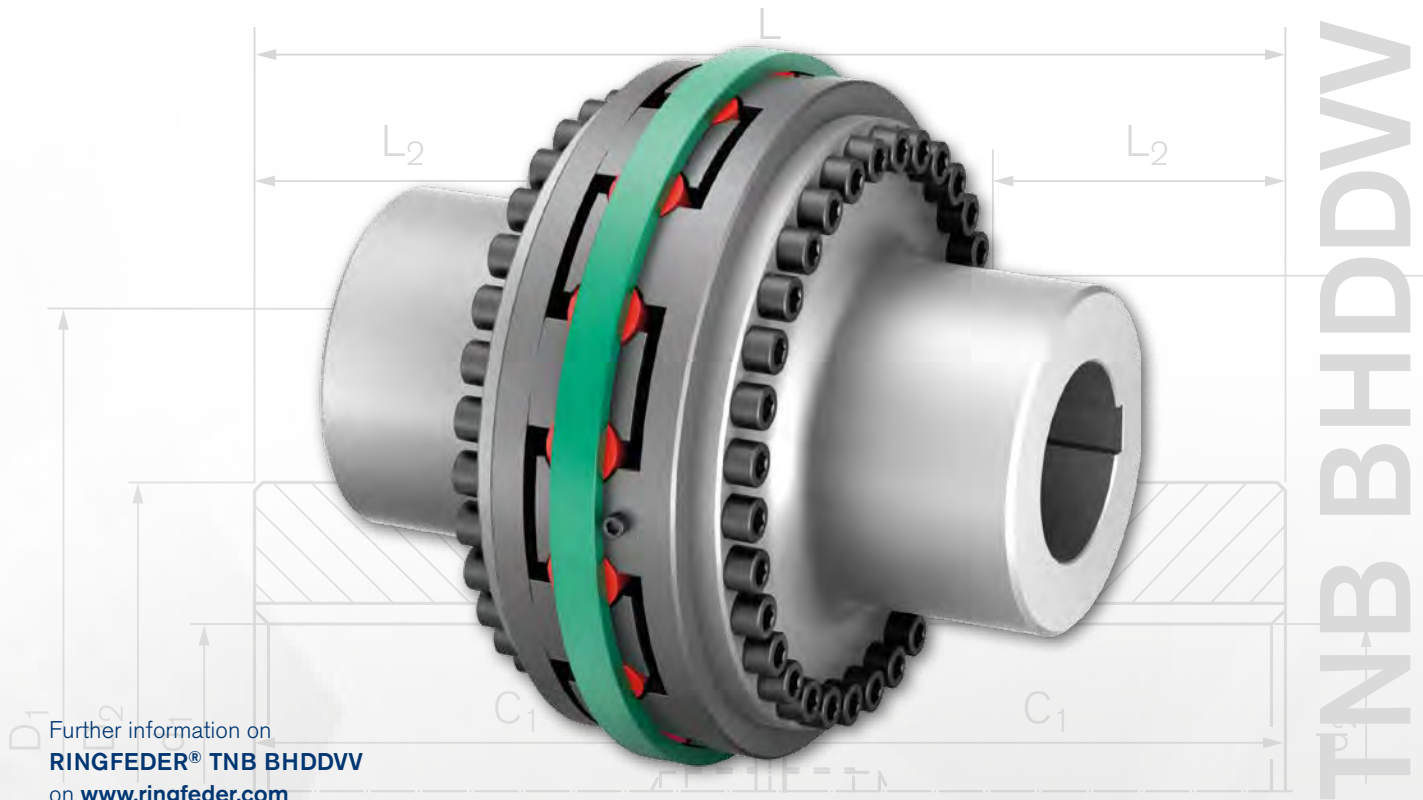

Further information on
RINGFEDER® TNB BHDDVV
on www.ringfeder.com

Symmetrical setup of multi-part design coupling hubs with very short shaft distances with VkR buffers

The RINGFEDER® TNB BHDDVV coupling is a torsionally elastic and puncture-proof jaw coupling. It balances out angular, radial and axial shaft offset within determined tolerances. The coupling transmits the torque via pre-compressed and radially freely accessible elastic individual buffers in synthetic rubber (Perbunan; Pb) or polyurethane (Vulkollan; Vk), in standard VkR. The elastic buffers can damp impacts and torsional vibrations and are oil resistant. The coupling can be used in any direction of rotation and installation position. When one jaw ring is pulled back this allows checking of the rotational direction. Material and length of the hubs can be adapted to customer requirements.

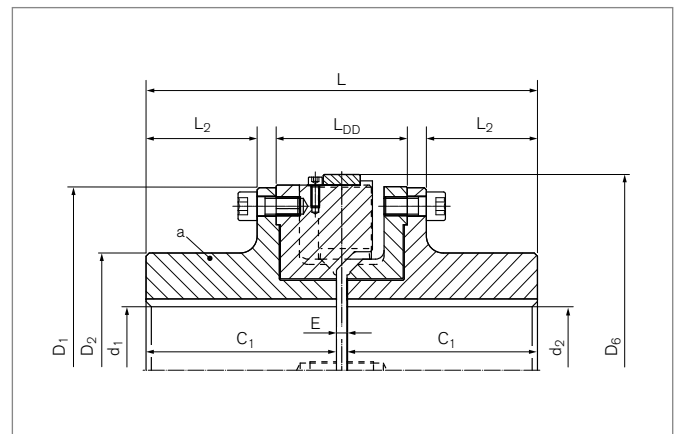

Characteristics

- Radially accessible individual buffers reduce assembly and maintenance work
- Torsionally elastic and puncture-proof, balances out angular, radial and axial shaft offset
- Optimisation of the vibration damping through different buffer hardness levels, usable from -30 °C to +100 °C.
- Hub material and design can be displayed as required
- Fitted with extraction and transportation bores
- Nominal torques $T_{KN} = 180000 \text{ Nm}$



Elastomer Jaw Couplings **RINGFEDER®**

GWE, TNM, TNS, TNB

Tables & Values

The equations and recommendations from the chapter 'Dimensioning of coupling' must be taken into account in order to determine coupling size.

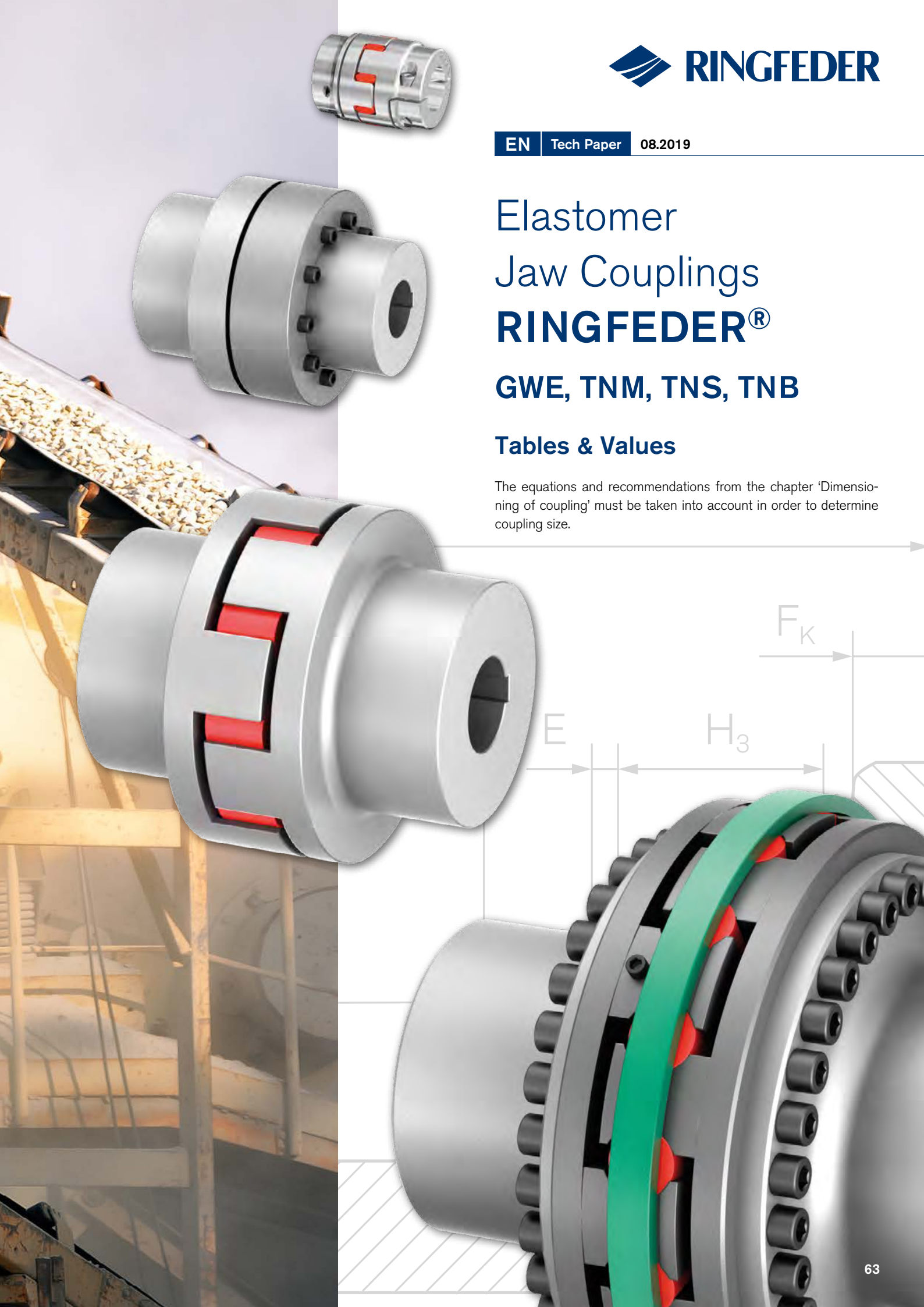

Elastomer Jaw Couplings

RINGFEDER® GWE 5102

Miniature coupling with set screw hubs

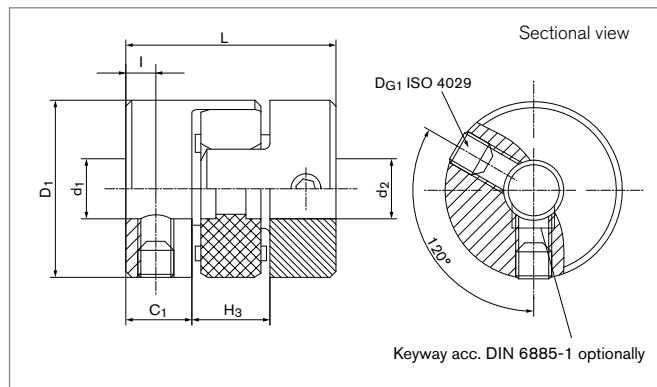

Size	$d_1; d_2$ min-max		$d_{1k}; d_{2k}$ min-max		C_1	D_1	H_3	l	L
	Without keyway	With keyway	Without keyway	With keyway					
	mm	mm	mm	mm	mm	mm	mm	mm	mm
5	2 - 5	---	---	---	5	10	5	2,5	15
7	3 - 8	6 - 8	6 - 8	6 - 8	7	14	8	3,5	22
9	3 - 12	6 - 10	6 - 10	6 - 10	10	20	10	5	30
12	4 - 12	6 - 12	6 - 12	6 - 12	11	25	12	5	34
14	4 - 16	6 - 16	6 - 16	6 - 16	11	30	13	5	35
19	6 - 24	6 - 24	6 - 24	6 - 24	25	40	16	10	66
24	8 - 35	8 - 35	8 - 35	8 - 35	30	55	18	10	78
28	---	10 - 38	10 - 38	10 - 38	35	65	20	15	90
38	---	12 - 48	12 - 48	12 - 48	45	80	24	15	114

Transmission of the couplings transmissible torque T can not longer be guaranteed for certain with borings $< d_{min}$. Types with borings $< d_{min}$, however, can be supplied.

Moment of inertia and weight (mass) are calculated with reference to the largest bore size.

Size	T	H_{es}	n_{max}	J	G_w	D_{G1}	T_{A1}
	Nm		1/min	10^{-3}kgm^2	kg	mm	Nm
5	0,5	92 SH A	47500	0,000034	0,005	1 x M3	1,3
7	1,2	92 SH A	34000	0,000196	0,009	1 x M3	1,3
9	3	92 SH A	24000	0,00108	0,017	2 x M4	3
12	5	92 SH A	19000	0,00284	0,03	2 x M4	5
14	7,5	92 SH A	16000	0,0057	0,041	2 x M6	6
19	10	92 SH A	12000	0,036	0,138	2 x M6	6
24	35	92 SH A	8500	0,162	0,282	2 x M6	6
28	95	92 SH A	7300	0,322	0,454	2 x M6	6
38	190	92 SH A	5900	0,954	0,876	2 x M6	6

To continue see next page

Elastomer Jaw Couplings RINGFEDER® GWE 5102

Transmissible torque T [Nm] of the Shaft-Hub-Connection

Size	Ø3	Ø4	Ø5	Ø6	Ø7	Ø8	Ø9	Ø10	Ø12	Ø14	Ø16	Ø18	Ø20	Ø22	Ø24	Ø28
5	0,5	0,5	0,5	---	---	---	---	---	---	---	---	---	---	---	---	---
7	1,2	1,2	1,2	1,2	1,2	1,2	---	---	---	---	---	---	---	---	---	---
9	3	3	3	3	3	3	3	3	3	---	---	---	---	---	---	---
12	---	5	5	5	5	5	5	5	5	---	---	---	---	---	---	---
14	---	7,5	7,5	7,5	7,5	7,5	7,5	7,5	7,5	7,5	7,5	---	---	---	---	---
19	---	---	---	10	10	10	10	10	10	10	10	10	10	10	10	---
24	---	---	---	---	---	20	22	24	29	34	35	35	35	35	35	35
28	---	---	---	---	---	---	---	95	95	95	95	95	95	95	95	95
38	---	---	---	---	---	---	---	---	190	190	190	190	190	190	190	190

Explanations

d₁;d_{2min} = Min. bore diameter d ₁ /d ₂	D₁ = Outer diameter	n_{max} = Max. rotation speed
d₁;d_{2max} = Max. bore diameter d ₁ /d ₂	H₃ = Length of damping module	J = Total moment of inertia
d_{1k};d_{2kmin} = Min. bore diameter d ₁ /d ₂ With keyway acc. to DIN 6885-1	l = Distance between center screw hole and hub end	Gw = Weight
d_{1k};d_{2kmax} = Max. bore diameter d ₁ /d ₂ With keyway acc. to DIN 6885-1	L = Total length	D_{G1} = Thread
C₁ = Guided length in hub bore	T = Transmissible torque at given T _A	T_{A1} = Tightened torque of clamping screw D _{G1}
	H_{es} = Hardness of the elastomeric spider	

Ordering example

Series Size	Bore diameter d ₁	Bore diameter d ₂	Spider hardness (optional) ¹⁾	Spider bore d _{bz} (optional) ¹⁾	Further details
GWE 5102-24	12	27	92 SH A	24	*

¹⁾ If a different spider hardness is selected, the detailed technical data for the sprockets must be observed. See chapter „Elastomer Jaw Couplings RINGFEDER® GWE Technical description“ in Product Paper & Tech Paper „RINGFEDER® Elastomer Jaw Couplings“

* Keyway

Further information on
RINGFEDER® GWE 5102
 on www.ringfeder.com

Disclaimer of liability

All technical details and notes are non-binding and cannot be used as a basis for legal claims. The user is obligated to determine whether the represented products meet his requirements. We reserve the right carry out modifications at any time in the interests of technical progress.

Elastomer Jaw Couplings

RINGFEDER® GWE 5103.1

Miniature coupling with extended clamping hubs and single slit

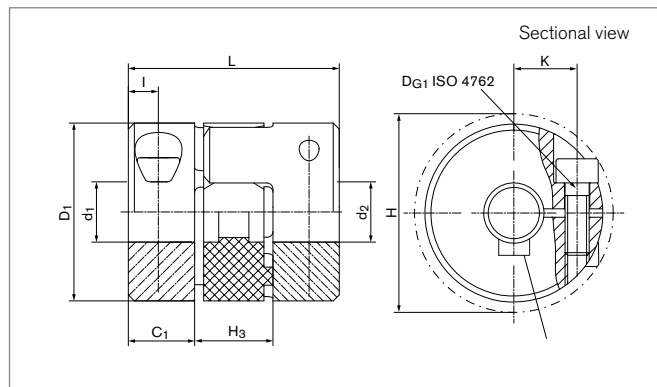

Size	d ₁ ;d ₂ min-max	d _{1k} ;d _{2k} min-max	C ₁	D ₁	H	H ₃	I	K	L
	mm	mm	mm	mm	mm	mm	mm	mm	mm
5	2 - 4	--- - ---	5	10	11,5	5	2,5	3,2	15
7	3 - 7	6 - 7	7	14	16,5	8	3,5	5	22
9	3 - 11	6 - 11	10	20	23,5	10	5	7,3	30

Transmission of the couplings transmissible torque T can not longer be guaranteed for certain with borings < d_{min}. Types with borings < d_{min}, however, can be supplied.

Moment of inertia and weight (mass) are calculated with reference to the largest bore size.

Size	T	H _{es}	n _{max}	J	G _w	D _{G1}	T _{A1}
	Nm		1/min	10 ⁻³ kgm ²	kg	mm	Nm
5	0,5	92 SH A	38000	0,000034	0,005	1 x M1,6	0,25
7	1,2	92 SH A	27000	0,000196	0,009	1 x M2	0,35
9	3	92 SH A	19000	0,00108	0,015	1 x M2,5	0,75

To continue see next page

Elastomer Jaw Couplings RINGFEDER® GWE 5103.1

Transmissible torque T [Nm]

Transmissible torque										
Size	Ø2	Ø3	Ø4	Ø5	Ø6	Ø7	Ø8	Ø9	Ø10	Ø11
Nm										
5	0,5	0,5	0,5	---	---	---	---	---	---	---
7	---	0,8	1,1	1,2	1,2	1,2	---	---	---	---
9	---	1,5	2	2,5	2,9	3	3	3	3	3

Explanations

d₁;d_{2min} = Min. bore diameter d ₁ /d ₂	H = Clearance diameter	n_{max} = Max. rotation speed
d₁;d_{2max} = Max. bore diameter d ₁ /d ₂	H₃ = Length of damping module	J = Total moment of inertia
d_{1k};d_{2kmin} = Min. bore diameter d ₁ /d ₂ With keyway acc. to DIN 6885-1	l = Distance between center screw hole and hub end	Gw = Weight
d_{1k};d_{2kmax} = Max. bore diameter d ₁ /d ₂ With keyway acc. to DIN 6885-1	K = Distance shaft axis - clamping screw axis	D_{G1} = Thread
C₁ = Guided length in hub bore	L = Total length	T_{A1} = Tightened torque of clamping screw D _{G1}
D₁ = Outer diameter	T = Transmissible torque at given T _A	
	H_{es} = Hardness of the elastomeric spider	

Ordering example

Series Size	Bore diameter d ₁	Bore diameter d ₂	Spider hardness (optional) ¹⁾	Spider bore d _{bz} (optional) ¹⁾	Further details
GWE 5103.1-9	10	11	80 SH A	6,5	*

¹⁾ If a different spider hardness is selected, the detailed technical data for the sprockets must be observed. See chapter „Elastomer Jaw Couplings RINGFEDER® GWE Technical description“ in Product Paper & Tech Paper „RINGFEDER® Elastomer Jaw Couplings“

* Keyway

Further information on
RINGFEDER® GWE 5103.1
 on www.ringfeder.com

Disclaimer of liability

All technical details and notes are non-binding and cannot be used as a basis for legal claims. The user is obligated to determine whether the represented products meet his requirements. We reserve the right carry out modifications at any time in the interests of technical progress.

Elastomer Jaw Couplings

RINGFEDER® GWE 5104

Servo-Insert coupling with clamping hubs and dual slits

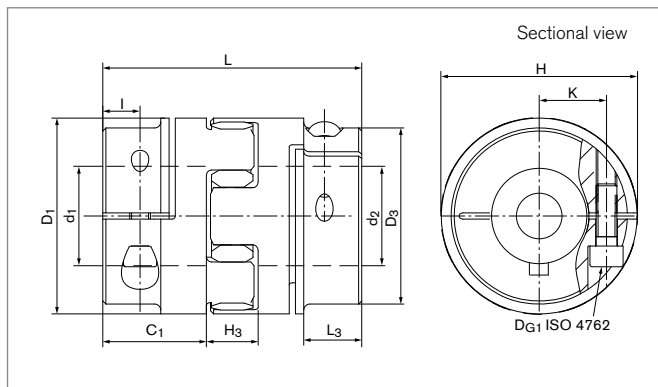

Size	d ₁ ;d ₂ min-max	d _{1k} ;d _{2k} min-max	C ₁	D ₁	D ₃	H	H ₃	I	K	L	L ₃
	mm	mm	mm	mm	mm	mm	mm	mm	mm	mm	mm
14	5 - 16	5 - 16	11	30	30	32,2	13	5	11	35	---
19	6 - 20	6 - 20	25	40	40	46	16	12	14,5	66	---
24	10 - 32	10 - 32	30	55	55	57	18	10,5	20	78	---
28	10 - 38	10 - 38	35	65	65	71	20	11,5	24,5	90	---
38	12 - 48	12 - 48	45	80	80	83	24	15,5	30	114	---
42	14 - 54	14 - 54	50	95	85	95	26	18	32,5	126	28
48	15 - 60	15 - 60	56	105	95	106	28	21	37	140	32
55	35 - 74	35 - 74	65	120	120	120	30	26	45	160	---
65	35 - 80	35 - 80	75	135	135	135	35	28	50	185	---
75	30 - 95	30 - 95	85	160	160	160	40	36	60	210	---

Transmission of the couplings transmissible torque T can not longer be guaranteed for certain with borings < d_{min}. Types with borings < d_{min}, however, can be supplied.

Moment of inertia and weight (mass) are calculated with reference to the largest bore size.

Size	T	H _{es}	n _{max}	J	Gw	DG1	T _{A1}
	Nm		1/min	10 ⁻³ kgm ²	kg	mm	Nm
14	12,5	98 SH A	13000	0,006	0,042	1 x M3	2
19	17	98 SH A	10000	0,036	0,158	1 x M6	11
24	60	98 SH A	7000	0,15	0,304	1 x M6	15
28	160	98 SH A	6000	0,33	0,505	1 x M8	32
38	325	98 SH A	5000	0,96	0,934	1 x M8	38
42	450	98 SH A	4000	4,92	3,8	1 x M10	84
48	525	98 SH A	3600	8,26	4,9	1 x M12	145
55	685	98 SH A	3150	19,15	10,2	1 x M12	145
65	940	98 SH A	2800	30,72	13,7	1 x M12	145
75	1920	98 SH A	2350	66,68	21,34	1 x M16	295

To continue see next page

Elastomer Jaw Couplings RINGFEDER® GWE 5104

Transmissible torque T [Nm]

Size	Transmissible torque																				
	Ø5	Ø6	Ø8	Ø10	Ø12	Ø14	Ø16	Ø20	Ø25	Ø30	Ø35	Ø40	Ø45	Ø50	Ø55	Ø60	Ø65	Ø70	Ø80	Ø90	Ø95
	Nm																				
14	4,8	6,0	7,7	9,4	11	12,5	12,5	---	---	---	---	---	---	---	---	---	---	---	---	---	---
19	---	16	17	17	17	17	17	17	---	---	---	---	---	---	---	---	---	---	---	---	---
24	---	---	---	37	43	50	56	60	60	60	---	---	---	---	---	---	---	---	---	---	---
28	---	---	---	61	72	83	94	114	138	160	160	---	---	---	---	---	---	---	---	---	---
38	---	---	---	---	87	100	113	138	168	197	225	251	277	---	---	---	---	---	---	---	---
42	---	---	---	---	---	174	197	242	296	348	398	450	450	---	---	---	---	---	---	---	---
48	---	---	---	---	---	---	276	343	424	502	525	525	525	525	525	---	---	---	---	---	---
55	---	---	---	---	---	---	---	---	---	---	630	685	685	685	685	685	685	685	685	---	---
65	---	---	---	---	---	---	---	---	---	---	634	714	791	866	940	940	940	940	940	940	---
75	---	---	---	---	---	---	---	---	---	---	998	1125	1250	1370	1489	1604	1718	1830	1920	1920	1920

Explanations

d₁;d_{2min} = Min. bore diameter d ₁ /d ₂	D₃ = Outer diameter hub	T = Transmissible torque at given T _A
d₁;d_{2max} = Max. bore diameter d ₁ /d ₂	H = Clearance diameter	H_{es} = Hardness of the elastomeric spider
d_{1k};d_{2kmin} = Min. bore diameter d ₁ /d ₂ with keyway acc. to DIN 6885-1	H₃ = Length of damping module	n_{max} = Max. rotation speed
d_{1k};d_{2kmax} = Max. bore diameter d ₁ /d ₂ with keyway acc. to DIN 6885-1	I = Distance between center screw hole and hub end	J = Total moment of inertia
C₁ = Guided length in hub bore	K = Distance shaft axis - clamping screw axis	Gw = Weight
D₁ = Outer diameter	L = Total length	D_{G1} = Thread
	L₃ = Length	T_{A1} = Tightened torque of clamping screw D _{G1}

Ordering example

Series Size	Bore diameter d ₁	Bore diameter d ₂	Spider hardness (optional) ¹⁾	Spider bore d _{bz} (optional) ¹⁾	Further details
GWE 5104-42	40	41	64 SH D	42	*

¹⁾ If a different spider hardness is selected, the detailed technical data for the sprockets must be observed. See chapter „Elastomer Jaw Couplings RINGFEDER® GWE Technical description“ in Product Paper & Tech Paper „RINGFEDER® Elastomer Jaw Couplings“

* Keyway

Further information on
RINGFEDER® GWE 5104
 on www.ringfeder.com

Disclaimer of liability

All technical details and notes are non-binding and cannot be used as a basis for legal claims. The user is obligated to determine whether the represented products meet his requirements. We reserve the right carry out modifications at any time in the interests of technical progress.

Elastomer Jaw Couplings

RINGFEDER® GWE 5106

Servo-Insert coupling with clamping hubs in split hub design

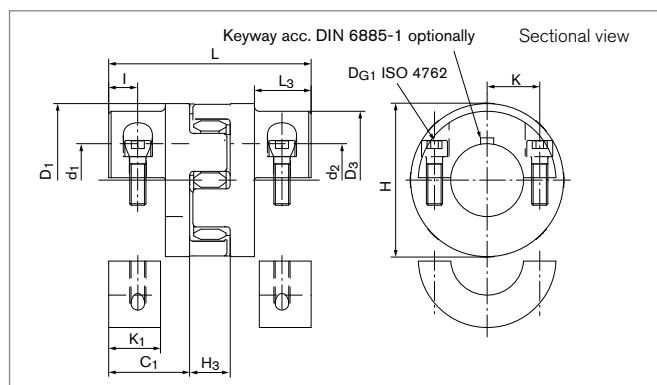

Size	d ₁ ;d ₂ min-max	d _{1k} ;d _{2k} min-max	C ₁	D ₁	D ₃	H	H ₃	I	K	K ₁	L	L ₃
	mm	mm	mm	mm	mm	mm	mm	mm	mm	mm	mm	mm
14	5 - 16	5 - 16	11	30	---	32,5	13	5	11	8	35	---
19	6 - 20	6 - 20	25	40	---	46	16	7	14,5	12	66	---
24	10 - 32	10 - 32	30	55	---	57	18	10,5	20	19	78	---
28	10 - 38	10 - 38	35	65	---	71	20	11,5	24,5	21,5	90	---
38	12 - 48	12 - 48	45	80	---	83	24	15,5	30	31	114	---
42	14 - 54	14 - 54	50	95	85	95	26	18	32,5	32	126	28
48	15 - 60	15 - 60	56	105	95	106	28	21	36	38	140	32
55	35 - 74	35 - 74	65	120	---	120	30	26	45	46,5	160	---
65	35 - 80	35 - 80	75	135	---	135	35	28	50	52	185	---
75	30 - 95	30 - 95	85	160	---	160	40	36	60	65,5	210	---

Transmission of the couplings transmissible torque T can not longer be guaranteed for certain with borings < d_{min}. Types with borings < d_{min}, however, can be supplied.

Moment of inertia and weight (mass) are calculated with reference to the largest bore size.

Size	T	H _{es}	n _{max}	J	Gw	D _{G1}	T _{A1}
	Nm		1/min	10 ⁻³ kgm ²	kg	mm	Nm
14	12,5	98 SH A	13000	0,006	0,042	2 x M3	2
19	17	98 SH A	10000	0,036	0,158	2 x M6	11
24	60	98 SH A	7000	0,15	0,304	2 x M6	15
28	160	98 SH A	6000	0,33	0,505	2 x M8	32
38	325	98 SH A	5000	0,96	0,934	2 x M8	38
42	450	98 SH A	4000	4,92	3,8	2 x M10	84
48	525	98 SH A	3600	8,26	4,9	2 x M12	145
55	685	98 SH A	3150	19,15	10,2	2 x M12	145
65	940	98 SH A	2800	30,72	13,7	2 x M12	145
75	1920	98 SH A	2350	66,68	21,34	2 x M16	295

To continue see next page

Elastomer Jaw Couplings RINGFEDER® GWE 5106

Transmissible torque T [Nm]

Size	Transmissible torque																				
	Ø5	Ø6	Ø8	Ø10	Ø12	Ø14	Ø16	Ø20	Ø25	Ø30	Ø35	Ø40	Ø45	Ø50	Ø55	Ø60	Ø65	Ø70	Ø80	Ø90	Ø95
	Nm																				
14	3,7	4,4	5,9	7,4	8,8	10,3	11,8	---	---	---	---	---	---	---	---	---	---	---	---	---	---
19	---	12,6	17	17	17	17	17	17	---	---	---	---	---	---	---	---	---	---	---	---	---
24	---	---	---	29	34	40	46	57	60	60	---	---	---	---	---	---	---	---	---	---	---
28	---	---	---	46	55	65	74	92	116	139	162	---	---	---	---	---	---	---	---	---	---
38	---	---	---	---	66	77	88	110	137	165	192	219	247	---	---	---	---	---	---	---	---
42	---	---	---	---	---	139	159	198	248	298	347	397	446	---	---	---	---	---	---	---	---
48	---	---	---	---	---	---	233	292	364	437	510	525	525	525	525	---	---	---	---	---	---
55	---	---	---	---	---	---	---	---	---	---	510	583	656	685	685	685	685	685	---	---	---
65	---	---	---	---	---	---	---	---	---	---	510	583	656	728	801	874	940	940	940	---	---
75	---	---	---	---	---	---	---	---	---	---	783	895	1007	1119	1231	1343	1455	1567	1790	1920	1920

Explanations

d₁;d_{2min} = Min. bore diameter d ₁ /d ₂	H = Clearance diameter	T = Transmissible torque at given T _A
d₁;d_{2max} = Max. bore diameter d ₁ /d ₂	H₃ = Length of damping module	H_{es} = Hardness of the elastomeric spider
d_{1k};d_{2kmin} = Min. bore diameter d ₁ /d ₂ with keyway acc. to DIN 6885-1	l = Distance between center screw hole and hub end	n_{max} = Max. rotation speed
d_{1k};d_{2kmax} = Max. bore diameter d ₁ /d ₂ with keyway acc. to DIN 6885-1	K = Distance shaft axis - clamping screw axis	J = Total moment of inertia
C₁ = Guided length in hub bore	K₁ = Clamping length	Gw = Weight
D₁ = Outer diameter	L = Total length	D_{G1} = Thread
	L₃ = Length	T_{A1} = Tightened torque of clamping screw D _{G1}

Ordering example

Series Size	Bore diameter d ₁	Bore diameter d ₂	Spider hardness (optional) ¹⁾	Spider bore d _{bz} (optional) ¹⁾	Further details
GWE 5106-42	40	41	92 SH A	42	*

¹⁾ If a different spider hardness is selected, the detailed technical data for the sprockets must be observed. See chapter „Elastomer Jaw Couplings RINGFEDER® GWE Technical description“ in Product Paper & Tech Paper „RINGFEDER® Elastomer Jaw Couplings“

* Keyway

Further information on
RINGFEDER® GWE 5106
 on www.ringfeder.com

Disclaimer of liability

All technical details and notes are non-binding and cannot be used as a basis for legal claims. The user is obligated to determine whether the represented products meet his requirements. We reserve the right carry out modifications at any time in the interests of technical progress.

Elastomer Jaw Couplings

RINGFEDER® GWE 5112

Servo-Insert coupling with outer cone

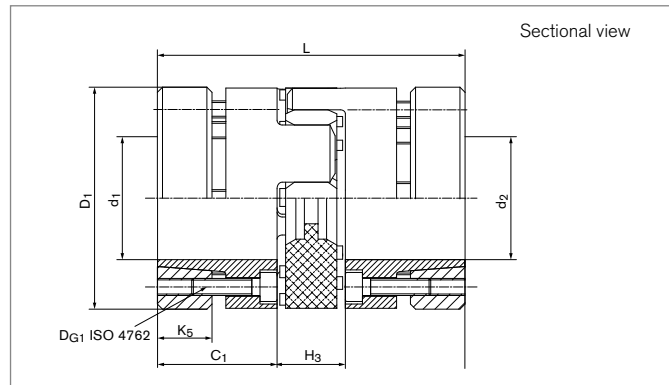

Size	d ₁ ;d ₂ min-max	C ₁	D ₁	H ₃	K ₅	L
	mm	mm	mm	mm	mm	mm
14	6 - 14	18,5	32	13	8	50
19	8 - 20	25	40	16	10	66
24	11 - 25	30	55	18	13	78
28	15 - 36	35	65	20	16	90
38	20 - 41	45	80	24	22	114
42	25 - 50	50	95	26	25	126
48	28 - 55	56	105	28	28	140

Transmission of the couplings transmissible torque T can not longer be guaranteed for certain with borings < d_{min}. Types with borings < d_{min} however, can be supplied.

Moment of inertia and weight (mass) are calculated with reference to the largest bore size.

Size	T	H _{es}	n _{max}	J	Gw	DG ₁	T _{A1}
	Nm		1/min	10 ⁻³ kgm ²	kg	mm	Nm
14	12,5	98 SH A	25400	0,014	0,042	4 x M3	1,8
19	17	98 SH A	19000	0,063	0,158	6 x M4	3
24	60	98 SH A	13800	0,26	0,304	4 x M5	6
28	160	98 SH A	11700	0,63	0,505	8 x M5	6
38	325	98 SH A	9550	1,96	0,934	8 x M6	10
42	450	98 SH A	8050	6,43	3,8	4 x M8	35
48	525	98 SH A	7200	10,54	4,9	4 x M10	69

To continue see next page

Elastomer Jaw Couplings RINGFEDER® GWE 5112

Transmissible torque T [Nm]

Size	Transmissible torque																				
	Ø6	Ø10	Ø11	Ø13	Ø14	Ø15	Ø17	Ø19	Ø20	Ø24	Ø25	Ø27	Ø30	Ø32	Ø36	Ø38	Ø42	Ø44	Ø48	Ø50	Ø55
	Nm																				
14	3,6	9	12,5	12,5	12,5	---	---	---	---	---	---	---	---	---	---	---	---	---	---	---	---
19	---	17	17	17	17	17	17	17	17	---	---	---	---	---	---	---	---	---	---	---	---
24	---	---	22	37	46	56	60	60	60	60	60	---	---	---	---	---	---	---	---	---	---
28	---	---	---	---	---	56	68	114	134	160	160	160	160	160	160	---	---	---	---	---	---
38	---	---	---	---	---	---	---	---	134	230	261	325	325	325	325	325	---	---	---	---	---
42	---	---	---	---	---	---	---	---	---	---	260	329	450	450	450	450	450	450	450	450	---
48	---	---	---	---	---	---	---	---	---	---	---	---	326	450	525	525	525	525	525	525	525

Explanations

d₁;d_{2min} = Min. bore diameter d ₁ /d ₂	D₁ = Outer diameter	n_{max} = Max. rotation speed
d₁;d_{2max} = Max. bore diameter d ₁ /d ₂	H₃ = Length of damping module	J = Total moment of inertia
d_{1k};d_{2kmin} = Min. bore diameter d ₁ /d ₂ with keyway acc. to DIN 6885-1	K₅ = Width of clamping ring	Gw = Weight
d_{1k};d_{2kmax} = Max. bore diameter d ₁ /d ₂ with keyway acc. to DIN 6885-1	L = Total length	D_{G1} = Thread
C₁ = Guided length in hub bore	T = Transmissible torque at given T _A	T_{A1} = Tightened torque of clamping screw D _{G1}
	H_{es} = Hardness of the elastomeric spider	

Ordering example

Series Size	Bore diameter d ₁	Bore diameter d ₂	Spider hardness (optional) ¹⁾	Spider bore d _{bz} (optional) ¹⁾
GWE 5112-42	32	41	64 SH D	42

¹⁾ If a different spider hardness is selected, the detailed technical data for the sprockets must be observed. See chapter „Elastomer Jaw Couplings RINGFEDER® GWE Technical description“ in Product Paper & Tech Paper „RINGFEDER® Elastomer Jaw Couplings“

Further information on
RINGFEDER® GWE 5112
 on www.ringfeder.com

Disclaimer of liability

All technical details and notes are non-binding and cannot be used as a basis for legal claims. The user is obligated to determine whether the represented products meet his requirements. We reserve the right carry out modifications at any time in the interests of technical progress.

Elastomer Jaw Couplings

RINGFEDER® GWE 5113

Servo-Insert coupling with clamping hubs, short length and single slit

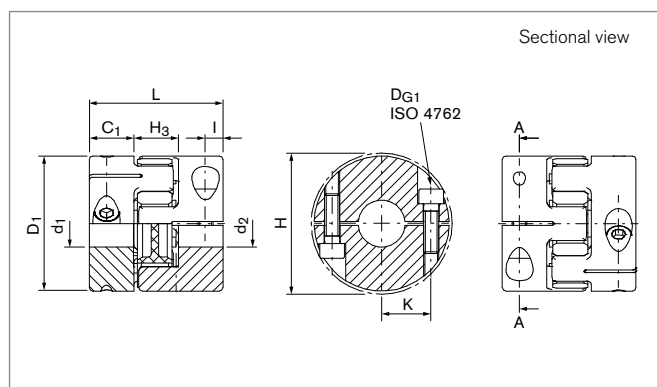

Size	d ₁ ;d ₂ min-max		d _{1k} ;d _{2k} min-max		C ₁	D ₁	H	H ₃	I	K	L
	Without keyway	With keyway	Without keyway	With keyway							
	mm	mm	mm	mm	mm	mm	mm	mm	mm	mm	mm
12	4 - 12	6 - 12	11	24,5	26	12	5	8,1	34		
14	5 - 15	6 - 15	9,5	29,5	33	13	5	10,5	32		
19	8 - 20	8 - 20	17	39,5	45	16	8	14	50		
24	10 - 32	10 - 32	18	54,5	57	18	7	20	54		
28	14 - 35	14 - 35	21	64,5	68	20	9	23,8	62		
38	15 - 45	15 - 45	26,5	79,5	86	23	13	29,5	76		
42	20 - 56	20 - 56	38	94,5	95	26	13,5	35	102		

Larger bore diameters (d₁, d₂) than specified in the table above can be realized in specific case of need. Please consult our experts in this matter. Transmission of the couplings' transmissible torque T can not longer be guaranteed for certain with

borings < d_{min}. Types with borings < d_{min}, however, can be supplied. Moment of inertia and weight (mass) are calculated with reference to the largest bore size.

Size	T	η _{max}	J	H _{es}	D _{G1}	T _{A1}	G _w
	Nm	1/min	10 ⁻³ kgm ²		mm	Nm	kg
12	9	15000	0,00296	98 SH A	2 x M3	2,1	0,033
14	12,5	13000	0,006	98 SH A	2 x M4	5	0,05
19	17	10000	0,029	98 SH A	2 x M6	14	0,14
24	60	7000	0,104	98 SH A	2 x M6	15	0,21
28	160	6000	0,250	98 SH A	2 x M8	35	0,377
38	325	5000	0,713	98 SH A	2 x M10	49	0,694
42	450	4000	1,793	98 SH A	2 x M10	69	1,21

To continue see next page

Elastomer Jaw Couplings RINGFEDER® GWE 5113

Transmissible torque T [Nm] of the Shaft-Hub-Connection

Size	Ø3	Ø4	Ø5	Ø6	Ø8	Ø10	Ø12	Ø14	Ø15	Ø18	Ø20	Ø25	Ø26	Ø28	Ø30	Ø35	Ø40	Ø45	Ø50	Ø55	Ø56
	Nm																				
12	---	3,5	4,3	5,1	6,8	8,4	9	---	---	---	---	---	---	---	---	---	---	---	---	---	---
14	---	---	8,4	10,2	12,5	12,5	12,5	12,5	12,5	---	---	---	---	---	---	---	---	---	---	---	---
19	---	---	---	---	17	17	17	17	17	17	17	---	---	---	---	---	---	---	---	---	---
24	---	---	---	---	---	35	42	48	52	60	60	60	60	60	60	---	---	---	---	---	---
28	---	---	---	---	---	---	---	96	102	121	133	160	160	160	160	160	---	---	---	---	---
38	---	---	---	---	---	---	---	143	172	191	238	248	267	286	325	325	325	---	---	---	---
42	---	---	---	---	---	---	---	---	---	---	221	277	288	310	332	387	443	450	450	450	450

Explanations

d₁;d_{2min} = Min. bore diameter d ₁ /d ₂	H = Clearance diameter	J = Total moment of inertia
d₁;d_{2max} = Max. bore diameter d ₁ /d ₂	H₃ = Length of damping module	H_{es} = Hardness of the elastomeric spider
d_{1k};d_{2kmin} = Min. bore diameter d ₁ /d ₂ With keyway acc. to DIN 6885-1	l = Distance between center screw hole and hub end	D_{G1} = Thread
d_{1k};d_{2kmax} = Max. bore diameter d ₁ /d ₂ With keyway acc. to DIN 6885-1	K = Distance shaft axis - clamping screw axis	T_{A1} = Tightened torque of clamping screw D _{G1}
C₁ = Guided length in hub bore	L = Total length	Gw = Weight
D₁ = Outer diameter	T = Transmissible torque at given T _A	
	n_{max} = Max. rotation speed	

Ordering example

Series Size	Bore diameter d ₁	Bore diameter d ₂	Spider hardness (optional) ¹⁾	Spider bore d _{bz} (optional) ¹⁾	Further details
GWE 5113-42	20	42	98 SH A	42	*

¹⁾ If a different spider hardness is selected, the detailed technical data for the sprockets must be observed. See chapter „Elastomer Jaw Couplings RINGFEDER® GWE Technical description“ in Product Paper & Tech Paper „RINGFEDER® Elastomer Jaw Couplings“

* Keyway or stainless steel

Further information on
RINGFEDER® GWE 5113
 on www.ringfeder.com

Disclaimer of liability

All technical details and notes are non-binding and cannot be used as a basis for legal claims. The user is obligated to determine whether the represented products meet his requirements. We reserve the right carry out modifications at any time in the interests of technical progress.

Elastomer Jaw Couplings

RINGFEDER® GWE 5117

Servo-Insert coupling with clamping hubs and expanding clamps

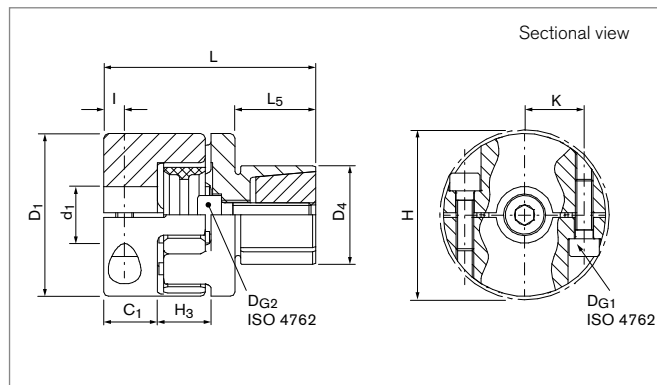

Size	d ₁ min-max	d _{1k} min-max	C ₁	D ₁	D ₄ min-max	H	H ₃	I	K	L	L ₅
	mm	mm	mm	mm	mm	mm	mm	mm	mm	mm	mm
12	4 - 12	6 - 12	11	24,5	10 - 15	26	12	5	8,1	42	12
14	5 - 15	6 - 15	9,5	29,5	13 - 25	33	13	5	10,5	47,5	20
19	8 - 20	8 - 20	17	39,5	14 - 30	45	16	8	14	65,5	25
24	10 - 32	10 - 32	18	54,5	23 - 36	57	18	7	20	71	27
28	14 - 35	14 - 35	21	64,5	26 - 42	68	19	9	23,8	82	32

Transmission of the couplings transmissible torque T can not longer be guaranteed for certain with borings < d_{min}. Types with borings < d_{min}, however, can be supplied.

Moment of inertia and weight (mass) are calculated with reference to the largest bore size.

Size	T	H _{es}	n _{max}	J	Gw	D _{G1}	T _{A1}	D _{G2}	T _{A2}
	Nm		1/min	10 ⁻³ kgm ²	kg	mm	Nm	mm	Nm
12	9	98 SH A	15000	0,0043	0,06	2 x M3	2,1	1 x M4	4
14	12,5	98 SH A	13000	0,008	0,09	2 x M4	5	1 x M5	9
19	17	98 SH A	10000	0,036	0,18	2 x M6	14	1 x M6	12
24	60	98 SH A	7000	0,138	0,38	2 x M6	15	1 x M8	32
28	160	98 SH A	6000	0,318	0,67	2 x M8	35	1 x M10	60

To continue see next page

Elastomer Jaw Couplings RINGFEDER® GWE 5117

Transmissible torque T [Nm]

Size	Ø4	Ø5	Ø6	Ø8	Ø10	Ø12	Ø14	Ø15	Ø18	Ø20	Ø25	Ø26	Ø28	Ø30	Ø35
12	3,5	4,3	5,1	6,8	8,4	9	---	---	---	---	---	---	---	---	---
14	---	8,4	10,2	12,5	12,5	12,5	12,5	12,5	---	---	---	---	---	---	---
19	---	---	---	17	17	17	17	17	17	17	---	---	---	---	---
24	---	---	---	---	35	42	48	52	60	60	60	60	60	60	---
28	---	---	---	---	---	---	96	102	121	133	160	160	160	160	160

Explanations

d_{1min} = Min. bore diameter d ₁	H = Clearance diameter	Gw = Weight
d_{1max} = Max. bore diameter d ₁	H₃ = Length of damping module	D_{G1} = Thread
d_{1kmin} = Min. bore diameter d ₁ with keyway acc. to DIN 6885-1	l = Distance between center screw hole and hub end	T_{A1} = Tightened torque of clamping screw D _{G1}
d_{1kmax} = Max. bore diameter d ₁ with keyway acc. to DIN 6885-1	K = Distance shaft axis - clamping screw axis	D_{G2} = Thread
C₁ = Guided length in hub bore	L = Total length	T_{A2} = Tightened torque of clamping screw D _{G2}
D₁ = Outer diameter	L₅ = Expanding mandrel length	
D_{4 min} = Min. outer diameter of the cone hub	T = Transmissible torque at given T _A	
D_{4 max} = Max. outer diameter of the cone hub	H_{es} = Hardness of the elastomeric spider	
	n_{max} = Max. rotation speed	
	J = Total moment of inertia	

Ordering example

Series Size	Bore diameter d ₁	Outer diameter of the cone hub D ₄	Spider hardness (optional) ¹⁾	Spider bore d _{bz} (optional) ¹⁾	Further details
GWE 5117-24	25	30	92 SH A	24	*

¹⁾ If a different spider hardness is selected, the detailed technical data for the sprockets must be observed. See chapter „Elastomer Jaw Couplings RINGFEDER® GWE Technical description“ in Product Paper & Tech Paper „RINGFEDER® Elastomer Jaw Couplings“

* Keyway

Further information on
RINGFEDER® GWE 5117
 on www.ringfeder.com

Disclaimer of liability

All technical details and notes are non-binding and cannot be used as a basis for legal claims. The user is obligated to determine whether the represented products meet his requirements. We reserve the right carry out modifications at any time in the interests of technical progress.

Elastomer Jaw Couplings

RINGFEDER® GWE Z5104.1

Servo-Insert coupling with clamping hubs for large shaft spacings

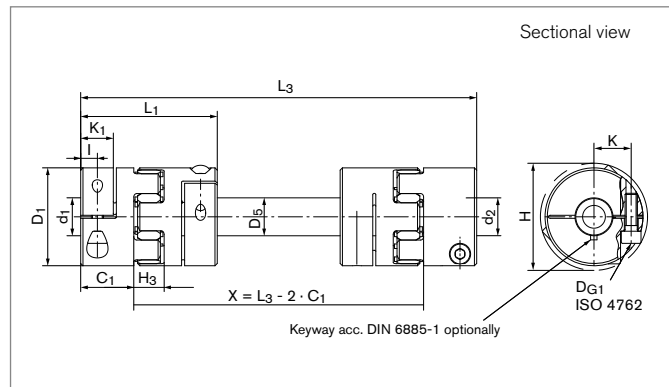

Size	d ₁ ;d ₂ min-max	d _{1k} ;d _{2k} min-max	C ₁	D ₁	D ₅	H	H ₃	I	K	K ₁	L ₁	L ₃ min-max
	mm	mm	mm	mm	mm	mm	mm	mm	mm	mm	mm	mm
14	5 - 16	5 - 16	11	30	16	31,6	13	5	11	11	35	80 - 2000
19	6 - 20	6 - 20	25	40	20	46	16	12	14,5	25	66	135 - 2000
24	10 - 32	10 - 32	30	55	25	57	18	10,5	20	19	78	160 - 2000
28	10 - 38	10 - 38	35	65	30	71	20	11,5	24,5	21,5	90	185 - 2000
38	12 - 48	12 - 48	45	80	40	83	24	15,5	30	31	114	230 - 2000
42	14 - 54	14 - 54	50	95	40	95	26	18	32,5	32	126	255 - 2000
48	15 - 60	15 - 60	56	105	50	104,5	28	21	36	38	140	290 - 2000

Transmission of the couplings transmissible torque T can not longer be guaranteed for certain with borings < d_{min}. Types with borings < d_{min}, however, can be supplied.

Size	T	C _m	H _{es}	D _{G1}	T _{A1}
	Nm	Nm/rad		mm	Nm
14	12,5	510	98 SH A	1 x M3	2
19	17	966	98 SH A	1 x M6	11
24	60	2635	98 SH A	1 x M6	15
28	160	5549	98 SH A	1 x M8	32
38	325	15470	98 SH A	1 x M8	38
42	450	15470	98 SH A	1 x M10	84
48	525	43514	98 SH A	1 x M12	145

To continue see next page

Elastomer Jaw Couplings RINGFEDER® GWE Z5104.1

Transmissible torque T [Nm]

Size	Ø5	Ø6	Ø8	Ø9	Ø10	Ø12	Ø14	Ø15	Ø16	Ø18	Ø20	Ø22	Ø24	Ø25	Ø30	Ø35	Ø40	Ø45	Ø50	Ø55	Ø58
	Nm																				
14	4,8	6,0	7,7	8,6	9,4	11	12,5	12,5	12,5	---	---	---	---	---	---	---	---	---	---	---	---
19	---	16	17	17	17	17	17	17	17	17	17	---	---	---	---	---	---	---	---	---	---
24	---	---	---	---	37	43	50	53	56	60	60	60	60	60	60	---	---	---	---	---	---
28	---	---	---	---	61	72	83	88	94	104	114	124	134	138	160	160	---	---	---	---	---
38	---	---	---	---	---	87	100	107	113	126	138	151	163	168	197	225	251	277	---	---	---
42	---	---	---	---	---	---	174	186	197	220	242	264	285	296	348	398	450	450	---	---	---
48	---	---	---	---	---	---	---	---	276	309	343	376	408	424	502	525	525	525	525	525	525

Critical bending speed for line shafts (operating speed = critical bending speed / 1,4)

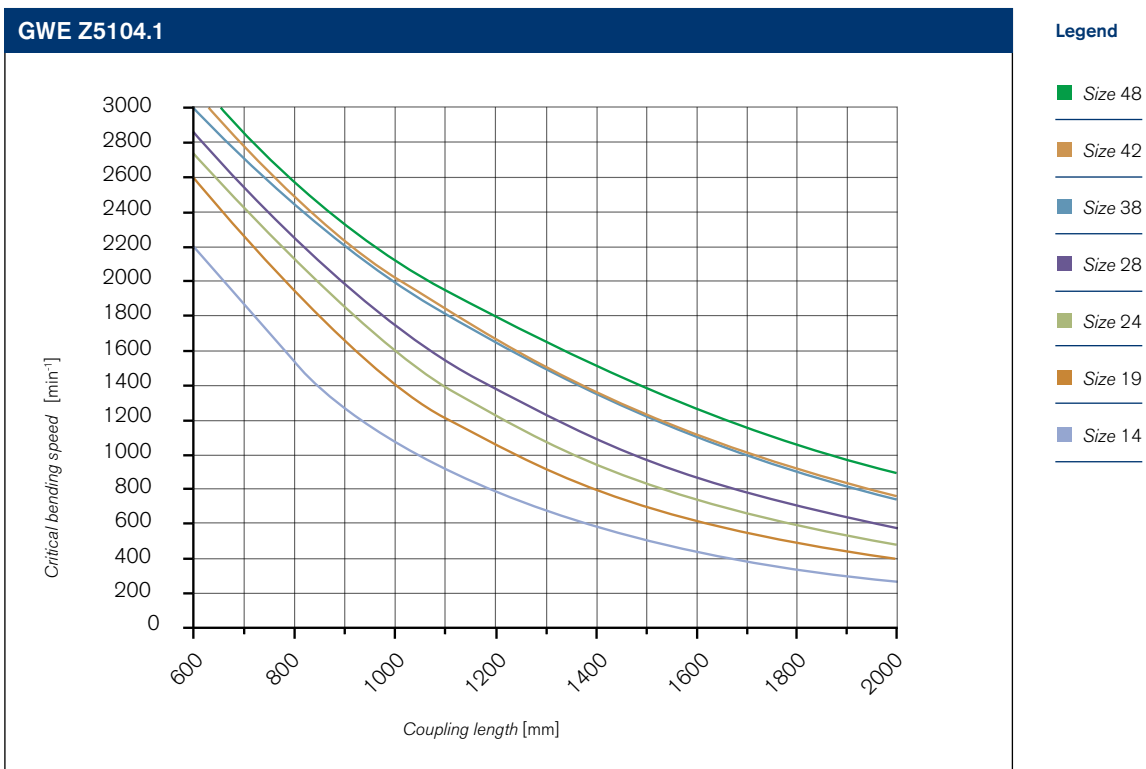

To continue see next page

Elastomer Jaw Couplings RINGFEDER® GWE Z5104.1

Explanations

d₁;d_{2min} = Min. bore diameter d ₁ /d ₂	H = Clearance diameter	L_{3max} = Max. length of line shaft
d₁;d_{2max} = Max. bore diameter d ₁ /d ₂	H₃ = Length of damping module	T = Transmissible torque at given T _A
d_{1k};d_{2kmin} = Min. bore diameter d ₁ /d ₂ with keyway acc. to DIN 6885-1	l = Distance between center screw hole and hub end	C_m = Torsional stiffness of extension tube per meter
d_{1k};d_{2kmax} = Max. bore diameter d ₁ /d ₂ with keyway acc. to DIN 6885-1	K = Distance shaft axis - clamping screw axis	H_{es} = Hardness of the elastomeric spider
C₁ = Guided length in hub bore	K₁ = Clamping length	D_{G1} = Thread
D₁ = Outer diameter	L₁ = Length of coupling	T_{A1} = Tightened torque of clamping screw D _{G1}
D₅ = Tube diameter	L_{3min} = Min. length of line shaft	

Ordering example

Series Size	Bore diameter d ₁	Bore diameter d ₂	Length of Line Shaft L ₃	Spider hardness (optional) ¹⁾	Spider bore d _{bz} (optional) ¹⁾	Further details
GWE Z5104.1-14	8	10	1000	64 SH D	8,5	*

¹⁾ If a different spider hardness is selected, the detailed technical data for the sprockets must be observed. See chapter „Elastomer Jaw Couplings RINGFEDER® GWE Technical description“ in Product Paper & Tech Paper „RINGFEDER® Elastomer Jaw Couplings“

* Keyway

Further information on
RINGFEDER® GWE Z5104.1
 on www.ringfeder.com

Disclaimer of liability

All technical details and notes are non-binding and cannot be used as a basis for legal claims. The user is obligated to determine whether the represented products meet his requirements. We reserve the right carry out modifications at any time in the interests of technical progress.

Elastomer Jaw Couplings

RINGFEDER® GWE Z5106.1

Servo-Insert coupling with clamping hubs in split hub design for large shaft spacings

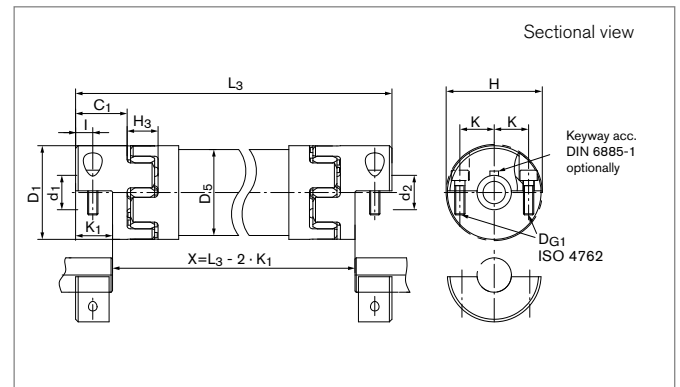

Size	d ₁ ;d ₂ min-max	d _{1k} ;d _{2k} min-max	C ₁	D ₁	D ₅	H	H ₃	I	K	K ₁	L ₃ min-max
	mm	mm	mm	mm	mm	mm	mm	mm	mm	mm	mm
14	5 - 16	5 - 16	11,0	30	30	32,0	13	5,0	11,0	9,0	85 - 3000
19	6 - 20	6 - 20	25,5	40	40	46,0	16	8,0	14,5	19,0	146 - 3000
24	10 - 32	10 - 32	30,0	55	50	57,0	18	10,5	20,0	21,0	180 - 3000
28	10 - 38	10 - 38	35,0	65	60	71,0	20	11,0	24,5	23,5	216 - 3000
38	12 - 48	12 - 48	45,0	80	80	83,0	24	15,5	30,0	33,0	266 - 3000
42	14 - 54	14 - 54	50,0	95	90	95,0	26	18,0	32,5	35,0	280 - 3000
48	15 - 60	15 - 60	57,5	105	100	104,5	28	21,0	37,0	41,0	296 - 3000

Size	T	C _m	H _{es}	D _{G1}	T _{A1}
	Nm	Nm/rad		mm	Nm
14	12,5	1526	98 SH A	2 x M3	2
19	17	3244	98 SH A	2 x M6	11
24	60	6631	98 SH A	2 x M6	15
28	160	11815	98 SH A	2 x M8	32
38	325	44929	98 SH A	2 x M8	38
42	450	75797	98 SH A	2 x M10	84
48	525	91158	98 SH A	2 x M12	145

To continue see next page

Elastomer Jaw Couplings RINGFEDER® GWE Z5106.1

Transmissible torque T [Nm]

Size	Ø5	Ø6	Ø8	Ø9	Ø10	Ø12	Ø14	Ø15	Ø16	Ø18	Ø20	Ø22	Ø24	Ø25	Ø30	Ø35	Ø40	Ø44	Ø48	Ø50	Ø58
	Nm																				
14	3,7	4,4	5,9	6,6	7,4	8,8	10,3	11,1	11,8	---	---	---	---	---	---	---	---	---	---	---	---
19	---	12,6	17	17	17	17	17	17	17	17	17	---	---	---	---	---	---	---	---	---	---
24	---	---	---	---	29	34	40	43	46	51	57	60	60	60	60	---	---	---	---	---	---
28	---	---	---	---	---	55	65	69	74	83	92	102	111	116	139	162	---	---	---	---	---
38	---	---	---	---	---	66	77	82	88	99	110	121	132	137	165	192	219	247	---	---	---
42	---	---	---	---	---	---	139	149	159	179	198	218	238	248	298	347	397	446	---	---	---
48	---	---	---	---	---	---	---	---	233	262	292	321	350	364	437	510	525	525	525	525	525

Critical bending speed for line shafts (operating speed = critical bending speed / 1,4)

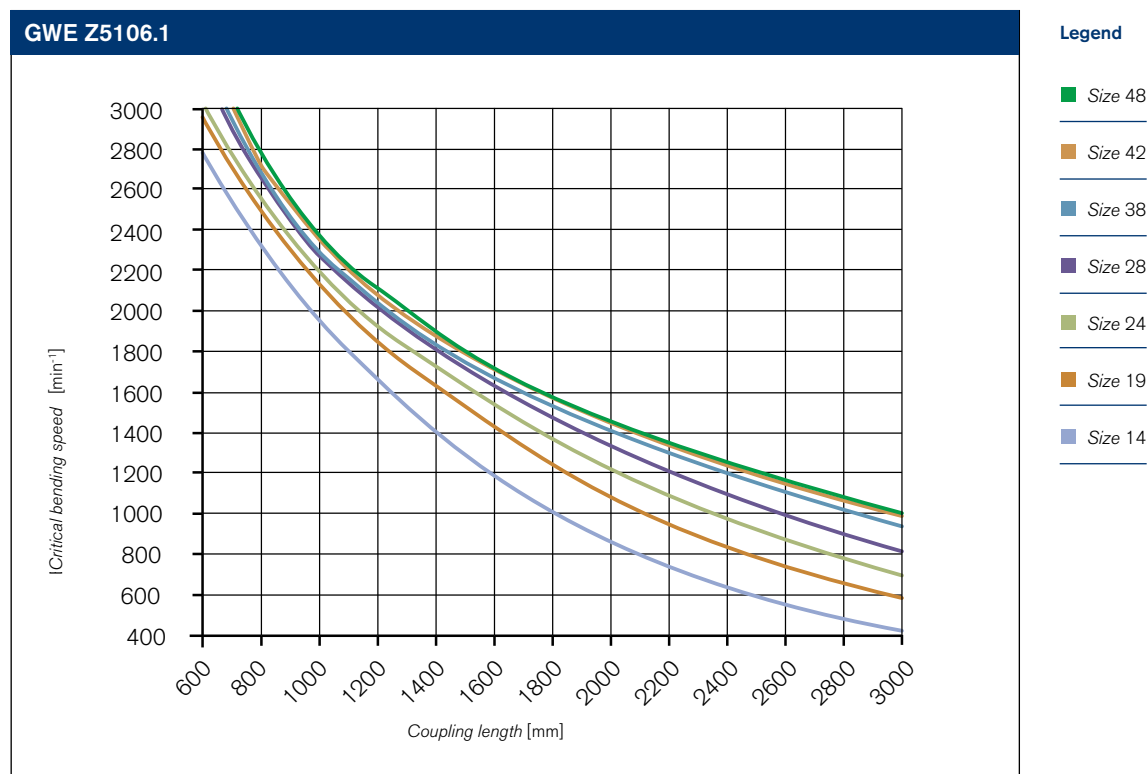

To continue see next page

Elastomer Jaw Couplings RINGFEDER® GWE Z5106.1

Explanations

d₁;d_{2min} = Min. bore diameter d ₁ /d ₂	H = Clearance diameter	T = Transmissible torque at given T _A
d₁;d_{2max} = Max. bore diameter d ₁ /d ₂	H₃ = Length of damping module	C_m = Torsional stiffness of extension tube per meter
d_{1k};d_{2kmin} = Min. bore diameter d ₁ /d ₂ with keyway acc. to DIN 6885-1	l = Distance between center screw hole and hub end	H_{es} = Hardness of the elastomeric spider
d_{1k};d_{2kmax} = Max. bore diameter d ₁ /d ₂ with keyway acc. to DIN 6885-1	K = Distance shaft axis - clamping screw axis	D_{G1} = Thread
C₁ = Guided length in hub bore	K₁ = Clamping length	T_{A1} = Tightened torque of clamping screw D _{G1}
D₁ = Outer diameter	L_{3min} = Min. length of line shaft	
D₅ = Tube diameter	L_{3max} = Max. length of line shaft	

Ordering example

Series Size	Bore diameter d ₁	Bore diameter d ₂	Length of Line Shaft L ₃	Spider hardness (optional) ¹⁾	Spider bore d _{bz} (optional) ¹⁾	Further details
GWE Z5106.1-14	8	10	1000	64 SH D	8,5	*

¹⁾ If a different spider hardness is selected, the detailed technical data for the sprockets must be observed. See chapter „Elastomer Jaw Couplings RINGFEDER® GWE Technical description“ in Product Paper & Tech Paper „RINGFEDER® Elastomer Jaw Couplings“

* Keyway

Further information on
RINGFEDER® GWE Z5106.1
 on www.ringfeder.com

Disclaimer of liability

All technical details and notes are non-binding and cannot be used as a basis for legal claims. The user is obligated to determine whether the represented products meet his requirements. We reserve the right carry out modifications at any time in the interests of technical progress.

Elastomer Jaw Couplings

RINGFEDER® TNM E

One-part design with 2 identical coupling hubs

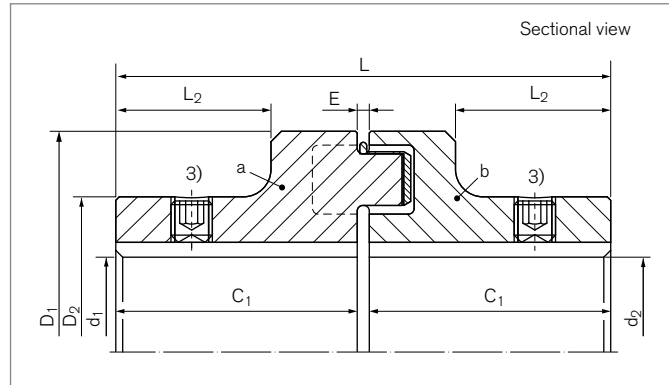
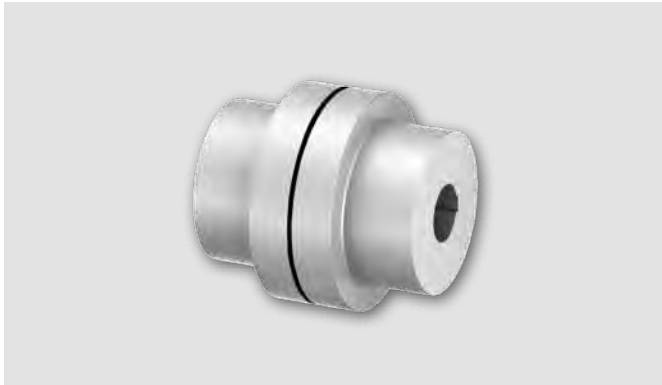

Identifier	Size	$T_{KNP672}^{(2)}$	$T_{KNPb82}^{(2)}$	n_{max}	d_{1kmax}	d_{2kmax}	D_1	D_2
		Nm	Nm	1/min	mm	mm	mm	mm
WNO105	50	13	20	5000	19	19	50	33
WNO106	67	22	35	5000	28	28	67	46
WNO108	82	48	75	5000	32	32	82	53
WNO109	97	96	150	5000	42	42	97	69
WNO111	112	150	230	5000	48	48	112	79
WNO112	128	250	380	5000	55	55	128	90
WNO114	148	390	600	4500	65	65	148	107
WNO116	168	630	980	4000	75	75	168	124
WNO119	194	1050	1650	3500	85	85	194	140
WNO121	214	1500	2400	3000	95	95	214	157
WNO124	240	2400	3700	2750	110	110	240	179
WNO126	265	3700	5800	2500	120	120	265	198
WNO129	295	4900	7550	2250	130	130	295	214
WNO133	330	6400	9900	2000	150	150	330	248
WNO137	370	8900	14000	1750	170	170	370	278
WNO141	415	13200	20500	1500	190	190	415	315
WNO148	480	18000	28000	2100	210	210	480	315
WNO157	575	27000	41000	1800	230	230	575	350

To continue see next page

Elastomer Jaw Couplings RINGFEDER® TNM E

Identifier	Size	C ₁	L	L ₂	E	F _E	G _{wa} ¹⁾	G _{wub}
		mm	mm	mm	mm	mm	kg	kg
WN0105	50	25	52	13	2	+/- 0,5	0,2	0,4
WN0106	67	30	62,5	15	2,5	+/- 0,5	0,5	1,0
WN0108	82	40	83	24	3	+/- 1,0	0,9	1,8
WN0109	97	50	103	30	3	+/- 1,0	1,7	3,4
WN0111	112	60	123,5	38	3,5	+/- 1,0	2,6	5,3
WN0112	128	70	143,5	45	3,5	+/- 1,0	4,1	8,2
WN0114	148	80	163,5	52	3,5	+/- 1,0	6,3	12,7
WN0116	168	90	183,5	56	3,5	+/- 1,5	9,6	19,3
WN0119	194	100	203,5	62	3,5	+/- 1,5	13,8	27,9
WN0121	214	110	224	68	4	+/- 2,0	19,1	38,2
WN0124	240	120	244	75	4	+/- 2,0	26,7	53,4
WN0126	265	140	285,5	90	5,5	+/- 2,5	37,5	75,0
WN0129	295	150	308	98	8	+/- 2,5	47,9	95,7
WN0133	330	160	328	104	8	+/- 2,5	66,5	132,9
WN0137	370	180	368	118	8	+/- 2,5	93,9	187,7
WN0141	415	200	408	135	8	+/- 2,5	129,7	259,3
WN0148	480	220	448	150	8	+/- 2,5	164,4	328,7
WN0157	575	240	488	170	8	+/- 2,5	233,5	467,0

¹⁾ Weight inclusive the half share of the intermediate ring
²⁾ Attention on peak load – see chapter „RINGFEDER® TNM Basic information“ in Product Paper & Tech Paper „RINGFEDER® Elastomer Jaw Couplings“
³⁾ Set screw on demand

Explanation

T_{KNPb72} = Coupling nominal torque by using the elastic element Pb72	d_{2kmax} = Max. bore diameter d ₂ with keyway acc. to DIN 6885-1	E = Gap width between left and right component
T_{KNPb82} = Coupling nominal torque by using the elastic element Pb82	D₁ = Outer diameter	F_E = Tolerance of the gap width E
n_{max} = Max. rotation speed	D₂ = Outer diameter hub	G_{wa} = Weight of subassembly a
d_{1kmax} = Max. bore diameter d ₁ with keyway acc. to DIN 6885-1	C₁ = Guided length in hub bore	G_{wub} = Weight, unbored
	L = Total length	
	L₂ = Length on the hub	

Ordering example

Identifier	Size	d _{1k}	d _{2k}	Buffer identifier (optional) ⁴⁾	Further details
WN0157	575	200	220	Pb82	*

⁴⁾ Details on elastomer materials see chapter „Introduction“ and „RINGFEDER® TNM Basic information“ in Product Paper & Tech Paper „RINGFEDER® Elastomer Jaw Couplings“
⁵⁾ Without any other specification, we deliver as a standard: with set screws and keyway acc. to DIN 6885-1, keyway side fit P9, bore tolerance H7

Further information on
RINGFEDER® TNM E
 on www.ringfeder.com

Disclaimer of liability

All technical details and notes are non-binding and cannot be used as a basis for legal claims. The user is obligated to determine whether the represented products meet his requirements. We reserve the right carry out modifications at any time in the interests of technical progress.

Elastomer Jaw Couplings

RINGFEDER® TNM G

Multi-part design, to change the intermediate ring without axial movement of the driven parts

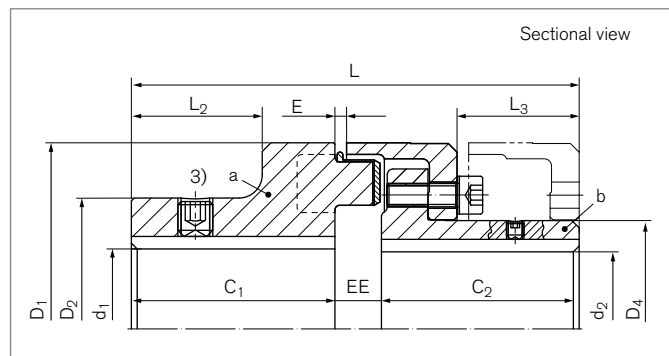

Identifier	Size	$T_{KNPb72}^{2)}$	$T_{KNPb82}^{2)}$	n_{max}	d_{1kmax}	d_{2kmax}	D_1	D_2	D_4	C_1
		Nm	Nm	1/min	mm	mm	mm	mm	mm	mm
WNO208	82	48	75	5000	32	32	82	53	44,5	40
WNO209	97	96	150	5000	42	39	97	69	54,5	50
WNO211	112	150	230	5000	48	46	112	79	64,5	60
WNO212	128	250	380	5000	55	53	128	90	74,5	70
WNO214	148	390	600	4500	65	65	148	107	92,5	80
WNO216	168	630	980	4000	75	75	168	124	104,5	90
WNO219	194	1050	1650	3500	85	85	194	140	121,5	100
WNO221	214	1500	2400	3000	95	95	214	157	135,5	110
WNO224	240	2400	3700	2750	110	100	240	179	146	120
WNO226	265	3700	5800	2500	120	115	265	198	164	140
WNO229	295	4900	7550	2250	130	130	295	214	181	150
WNO233	330	6400	9900	2000	150	135	330	248	208	160
WNO237	370	8900	14000	1750	170	160	370	278	241	180
WNO241	415	13200	20500	1500	190	180	415	315	275	200
WNO248	480	18000	28000	1400	210	200	480	315	289	220
WNO257	575	27000	41000	1200	230	260	575	350	368	240

To continue see next page

Elastomer Jaw Couplings RINGFEDER® TNM G

Identifier	Size	C ₂	L	L ₂	L ₃	E	F _E	EE	G _{wa} ¹⁾	G _{wub}
		mm	mm	mm	mm	mm	mm	mm	kg	kg
WN0208	82	40	92	24	20	3	+/- 1,0	12	0,9	2,0
WN0209	97	49	113	30	30,5	3	+/- 1,0	14	1,7	3,4
WN0211	112	58	133	38	32,5	3,5	+/- 1,0	15	2,6	5,5
WN0212	128	68	154	45	42	3,5	+/- 1,0	16	4,1	8,3
WN0214	148	78	176	52	47	3,5	+/- 1,0	18	6,3	13,1
WN0216	168	87	198	56	52,5	3,5	+/- 1,5	21	9,6	19,4
WN0219	194	97	221	62	60	3,5	+/- 1,5	24	13,8	28,6
WN0221	214	107	243	68	66,5	4	+/- 2,0	26	19,1	38,8
WN0224	240	117	267	75	75,5	4	+/- 2,0	30	26,7	52,4
WN0226	265	137	310	90	88	5,5	+/- 2,5	33	37,5	75,3
WN0229	295	147	334	98	96	8	+/- 2,5	37	47,9	97,3
WN0233	330	156	356	104	101,5	8	+/- 2,5	40	66,5	130,0
WN0237	370	176	399	118	117	8	+/- 2,5	43	93,9	183,6
WN0241	415	196	441	135	131	8	+/- 2,5	45	129,7	258,2
WN0248	480	220	485	150	149	8	+/- 2,5	45	164,4	346,5
WN0257	575	240	525	170	168	8	+/- 2,5	45	233,5	528,8

¹⁾ Weight inclusive the half share of the intermediate ring

²⁾ Attention on peak load – see chapter „RINGFEDER® TNM Basic information“ in Product Paper & Tech Paper „RINGFEDER® Elastomer Jaw Couplings“

³⁾ Set screw on demand

Explanation

T_{KNPb72} = Coupling nominal torque by using the elastic element Pb72	D₁ = Outer diameter	E = Gap width between left and right component
T_{KNPb82} = Coupling nominal torque by using the elastic element Pb82	D₂ = Outer diameter hub	F_E = Tolerance of the gap width E
n_{max} = Max. rotation speed	D₄ = Outer diameter hub	EE = Distance of the hubs
d_{1kmax} = Max. bore diameter d ₁ with keyway acc. to DIN 6885-1	C₁ = Guided length in hub bore	G_{wa} = Weight of subassembly a
d_{2kmax} = Max. bore diameter d ₂ with keyway acc. to DIN 6885-1	C₂ = Guided length in hub bore	G_{wub} = Weight, unbored
	L = Total length	
	L₂ = Length on the hub	
	L₃ = Length	

Ordering example

Identifier	Size	d _{1k}	d _{2k}	Buffer identifier (optional) ⁴⁾	Further details
WN0224	240	90	70	Pb82	*

⁴⁾ Details on elastomer materials see chapter „Introduction“ and „RINGFEDER® TNM Basic information“ in Product Paper & Tech Paper „RINGFEDER® Elastomer Jaw Couplings“

⁵⁾ Without any other specification, we deliver as a standard: with set screws and keyway acc. to DIN 6885-1, keyway side fit P9, bore tolerance H7

Further information on
RINGFEDER® TNM G
 on www.ringfeder.com

Disclaimer of liability

All technical details and notes are non-binding and cannot be used as a basis for legal claims. The user is obligated to determine whether the represented products meet his requirements. We reserve the right carry out modifications at any time in the interests of technical progress.

Elastomer Jaw Couplings

RINGFEDER® TNM ETW

One part design with brake disc

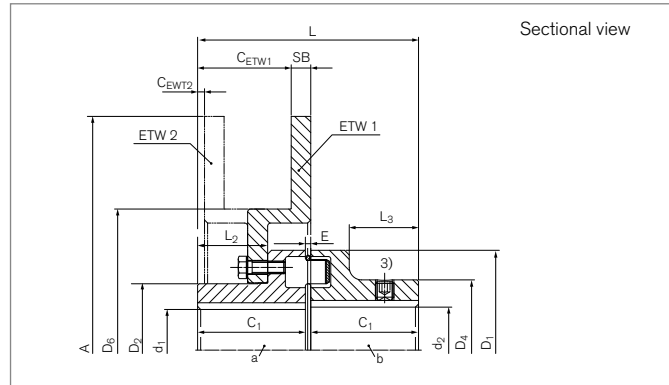

Identifier	Size	A	SB	T _{KNPb72} ²⁾	T _{KNPb82} ²⁾	T _{BR} ⁴⁾	n _{max}	d _{1kmax}	d _{2kmax}	D ₁	D ₂	D ₄	D ₆	C ₁
		mm	mm	Nm	Nm	Nm	1/min	mm	mm	mm	mm	mm	mm	mm
WNO311-250	112	250	12,7	150	230	450	4580	42	48	112	68	79	128	60
WNO311-300	112	300	12,7	150	230	450	3820	42	48	112	68	79	181	60
WNO312-300	128	300	12,7	250	380	550	3820	52	55	128	85	90	181	70
WNO314-300	148	300	12,7	390	600	1000	3820	58	65	148	94	107	181	80
WNO316-356	168	356	12,7	630	980	1600	3225	72	75	168	118	124	210	90
WNO316-406	168	406	12,7	630	980	1600	2825	72	75	168	118	124	260	90
WNO319-406	194	406	12,7	1050	1650	2750	2825	85	85	194	138	140	260	100
WNO319-457	194	457	12,7	1050	1650	2750	2510	85	85	194	138	140	311	100
WNO321-406	214	406	12,7	1500	2400	3350	2825	92	95	214	153	157	260	110
WNO321-514	214	514	12,7	1500	2400	3350	2510	92	95	214	153	157	311	110
WNO324-457	240	457	12,7	2400	3700	4200	2510	102	110	240	168	179	311	120
WNO324-514	240	514	12,7	2400	3700	4200	2230	102	110	240	168	179	368	120
WNO326-457	265	457	12,7	3700	5800	8700	2510	120	120	265	195	198	311	140
WNO326-514	265	514	12,7	3700	5800	8700	2230	120	120	265	195	198	368	140
WNO329-514	295	514	12,7	4900	7550	9800	2230	130	130	295	214	214	368	150
WNO329-610	295	610	12,7	4900	7550	9800	1880	130	130	295	214	214	464	150
WNO333-514	330	514	12,7	6400	9900	10600	2230	150	150	330	248	248	368	160
WNO333-610	330	610	12,7	6400	9900	10600	1880	150	150	330	248	248	464	160
WNO337-610	370	610	12,7	8900	14000	13500	1880	170	170	370	278	278	464	180
WNO337-711	370	711	12,7	8900	14000	13500	1615	170	170	370	278	278	565	180
WNO341-610	415	610	12,7	13200	20500	16000	1880	185	190	415	308	315	464	200
WNO341-711	415	711	12,7	13200	20500	16000	1615	185	190	415	308	315	565	200
WNO341-812	415	812	12,7	13200	20500	16000	1410	185	190	415	308	315	660	200
WNO341-915	415	915	12,7	13200	20500	16000	1255	185	190	415	308	315	760	200

To continue see next page

Elastomer Jaw Couplings RINGFEDER® TNM ETW

Identifier	Size	CETW1 ¹⁾	CETW2 ¹⁾	L	L ₂	L ₃	E	F _E	G _{WBS}	G _{Wub}
		mm	mm	mm	mm	mm	mm	mm	kg	kg
WN0311-250	112	55,8	2,5	123,5	38,5	38	3,5	+/- 1,0	6,1	8,8
WN0311-300	112	53,8	-2,5	123,5	38,5	38	3,5	+/- 1,0	9,1	11,7
WN0312-300	128	60,8	4,5	143,5	45,5	45	3,5	+/- 1,0	10,5	14,6
WN0314-300	148	67,8	11,5	163,5	52,5	52	3,5	+/- 1,0	12,1	18,4
WN0316-356	168	81,8	2,5	183,5	56,5	56	3,5	+/- 1,5	18,4	28,0
WN0316-406	168	84,8	2,5	183,5	56,5	56	3,5	+/- 1,5	21,3	31,0
WN0319-406	194	90,8	8,5	203,5	62,5	62	3,5	+/- 1,5	25,2	39,1
WN0319-457	194	87,8	8,5	203,5	62,5	62	3,5	+/- 1,5	30,1	44,0
WN0321-406	214	96,8	14,5	224	68,5	68	4	+/- 2,0	29,7	48,8
WN0321-514	214	93,8	14,5	224,0	68,5	68	4	+/- 2,0	34,5	53,6
WN0324-457	240	100,8	21,5	244	75,5	75	4	+/- 2,0	40,4	67,0
WN0324-514	240	100,8	21,5	244	75,5	75	4	+/- 2,0	45,4	72,0
WN0326-457	265	115,8	36,5	285,5	90,5	90	5,5	+/- 2,5	51,9	89,4
WN0326-514	265	115,8	36,5	285,5	90,5	90	5,5	+/- 2,5	56,7	94,2
WN0329-514	295	123,8	44,5	308	98,5	98	8	+/- 2,5	65,7	113,5
WN0329-610	295	123,8	44,5	308	98,5	98	8	+/- 2,5	76,7	124,5
WN0333-514	330	129,8	50,5	328,0	104,5	104	8	+/- 2,5	82,8	149,3
WN0333-610	330	129,8	50,5	328	104,5	104	8	+/- 2,5	93,8	160,3
WN0337-610	370	143,8	64,5	368	118,5	118	8	+/- 2,5	118,8	212,7
WN0337-711	370	140,8	64,5	368	118,5	118	8	+/- 2,5	134,1	227,9
WN0341-610	415	160,8	81,5	408	135,5	135	8	+/- 2,5	149,8	279,5
WN0341-711	415	157,8	81,5	408	135,5	135	8	+/- 2,5	164,7	294,3
WN0341-812	415	151,8	81,5	408	135,5	135	8	+/- 2,5	196,8	326,4
WN0341-915	415	151,8	81,5	408	135,5	135	8	+/- 2,5	227,2	356,8

¹⁾ Assembly of brake disc optionally, standard combination ETW1, otherwise ETW2

²⁾ Attention on peak load – see chapter „RINGFEDER® TNM Basic information“ in Product Paper & Tech Paper „RINGFEDER® Elastomer Jaw Couplings“

³⁾ Set screw on demand

⁴⁾ Choose brake disc assembly in a way, that brake torque does not affect intermediate ring

To continue see next page

Elastomer Jaw Couplings RINGFEDER® TNM ETW

Explanation

A	= Max. outer diameter	D₁	= Outer diameter	L₃	= Length
SB	= Disc width	D₂	= Outer diameter hub	E	= Gap width between left and right component
T_{KNPb72}	= Coupling nominal torque by using the elastic element Pb72	D₄	= Outer diameter hub	FE	= Tolerance of the gap width E
T_{KNPb82}	= Coupling nominal torque by using the elastic element Pb82	D₆	= Diameter	GW_{BS}	= Weight of part with brake disc, unbored
T_{BR}	= Brake torque	C₁	= Guided length in hub bore	GW_{ub}	= Weight, unbored
n_{max}	= Max. rotation speed	CETW1	= Distance when using brake disc assembly ETW1		
d_{1kmax}	= Max. bore diameter d ₁ with keyway acc. to DIN 6885-1	CETW2	= Distance, when using brake disc assembly ETW2		
d_{2kmax}	= Max. bore diameter d ₂ with keyway acc. to DIN 6885-1	L	= Total length		
		L₂	= Length on the hub		

Ordering example

Identifier	Size	d _{1k}	d _{2k}	Buffer identifier (optional) ⁵⁾	Further details
WN0319-406	194	80	62	Pb82	*

⁵⁾ Details on elastomer materials see chapter „Introduction“ and „RINGFEDER® TNM Basic information“ in Product Paper & Tech Paper „RINGFEDER® Elastomer Jaw Couplings“

⁷⁾ Without any other specification, we deliver as a standard: with set screws and keyway acc. to DIN 6885-1, keyway side fit P9, bore tolerance H7

Further information on
RINGFEDER® TNM ETW
 on www.ringfeder.com

Disclaimer of liability

All technical details and notes are non-binding and cannot be used as a basis for legal claims. The user is obligated to determine whether the represented products meet his requirements. We reserve the right carry out modifications at any time in the interests of technical progress.

Elastomer Jaw Couplings

RINGFEDER® TNM GTW

Multi-part design, to change the intermediate ring without axial movement of the driven parts with brake disc

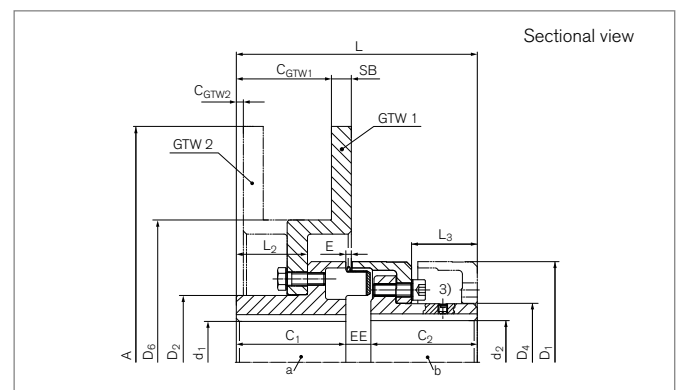

Identifier	Size	A	SB	T _{KNPb72} ²⁾	T _{KNPb82} ²⁾	T _{BR} ⁴⁾	n _{max}	d _{1kmax}	d _{2kmax}	D ₁	D ₂	D ₄	D ₆	C ₁	C ₂
		mm	mm	Nm	Nm	Nm	1/min	mm	mm	mm	mm	mm	mm	mm	mm
WNO411-250	112	250	12,7	150	230	450	4580	42	46	112	68	64,5	128	60	58
WNO411-300	112	300	12,7	150	230	450	3820	42	46	112	68	64,5	181	60	58
WNO412-300	128	300	12,7	250	380	550	3820	52	53	128	85	74,5	181	70	68
WNO414-300	148	300	12,7	390	600	1000	3820	58	65	148	94	92,5	181	80	78
WNO416-356	168	356	12,7	630	980	1600	3225	72	75	168	118	104,5	210	90	87
WNO416-406	168	406	12,7	630	980	1600	2825	72	75	168	118	104,5	260	90	87
WNO419-406	194	406	12,7	1050	1650	2750	2825	85	85	194	138	121,5	260	100	97
WNO419-457	194	457	12,7	1050	1650	2750	2510	85	85	194	138	121,5	311	100	97
WNO421-406	214	406	12,7	1500	2400	3350	2825	92	95	214	153	135,5	260	110	107
WNO421-514	214	514	12,7	1500	2400	3350	2510	92	95	214	153	135,5	311	110	107
WNO424-457	240	457	12,7	2400	3700	4200	2510	102	100	240	168	146	311	120	117
WNO424-514	240	514	12,7	2400	3700	4200	2230	102	100	240	168	146	368	120	117
WNO426-457	265	457	12,7	3700	5800	8700	2510	120	115	265	195	164	311	140	137
WNO426-514	265	514	12,7	3700	5800	8700	2230	120	115	265	195	164	368	140	137
WNO429-514	295	514	12,7	4900	7550	9800	2230	130	130	295	214	181	368	150	147
WNO429-610	295	610	12,7	4900	7550	9800	1880	130	130	295	214	181	464	150	147
WNO433-514	330	514	12,7	6400	9900	10600	2230	150	135	330	248	208	368	160	156
WNO433-610	330	610	12,7	6400	9900	10600	1880	150	135	330	248	208	464	160	156
WNO437-610	370	610	12,7	8900	14000	13500	1880	170	160	370	278	241	464	180	176
WNO437-711	370	711	12,7	8900	14000	13500	1615	170	160	370	278	241	565	180	176
WNO441-610	415	610	12,7	13200	20500	16000	1880	185	180	415	308	275	464	200	196
WNO441-711	415	711	12,7	13200	20500	16000	1615	185	180	415	308	275	565	200	196
WNO441-812	415	812	12,7	13200	20500	16000	1410	185	180	415	308	275	660	200	196
WNO441-915	415	915	12,7	13200	20500	16000	1255	185	180	415	308	275	760	200	196

To continue see next page

Elastomer Jaw Couplings RINGFEDER® TNM GTW

Identifier	Size	C _{GTW1} ¹⁾	C _{GTW2} ¹⁾	L	L ₂	L ₃	E	F _E	EE	G _{WBS}	G _{Wub}	
		mm	mm	mm	mm	mm	mm	mm	mm	mm	kg	kg
WNO411-250	112	55,8	2,5	133	38,5	32,5	3,5	+/- 1,0	15	6,1	8,8	
WNO411-300	112	53,8	-2,5	133	38,5	32,5	3,5	+/- 1,0	15	9,1	11,7	
WNO412-300	128	60,8	4,5	154	45,5	42	3,5	+/- 1,0	16	10,5	14,6	
WNO414-300	148	67,8	11,5	176	52,5	47	3,5	+/- 1,0	18	12,1	18,4	
WNO416-356	168	81,8	2,5	198	56,5	52,5	3,5	+/- 1,5	21	18,4	28,0	
WNO416-406	168	84,8	2,5	198	56,5	52,5	3,5	+/- 1,5	21	21,3	31,0	
WNO419-406	194	90,8	8,5	221	62,5	60	3,5	+/- 1,5	24	25,2	39,1	
WNO419-457	194	87,8	8,5	221	62,5	60	3,5	+/- 1,5	24	30,1	44,0	
WNO421-406	214	96,8	14,5	243	68,5	66,5	4	+/- 2,0	26	29,7	48,8	
WNO421-514	214	93,8	14,5	243	68,5	66,5	4	+/- 2,0	26	34,5	53,6	
WNO424-457	240	100,8	21,5	267	75,5	75,5	4	+/- 2,0	30	40,4	67,0	
WNO424-514	240	100,8	21,5	267	75,5	75,5	4	+/- 2,0	30	45,4	72,0	
WNO426-457	265	115,8	36,5	310	90,5	88	5,5	+/- 2,5	33	51,9	89,4	
WNO426-514	265	115,8	36,5	310	90,5	88	5,5	+/- 2,5	33	56,7	94,2	
WNO429-514	295	123,8	44,5	334	98,5	96	8	+/- 2,5	37	65,7	113,5	
WNO429-610	295	123,8	44,5	334	98,5	96	8	+/- 2,5	37	76,7	124,5	
WNO433-514	330	129,8	50,5	356	104,5	101,5	8	+/- 2,5	40	82,8	149,3	
WNO433-610	330	129,8	50,5	356	104,5	101,5	8	+/- 2,5	40	93,8	160,3	
WNO437-610	370	143,8	64,5	399	118,5	117	8	+/- 2,5	43	118,8	212,7	
WNO437-711	370	140,8	64,5	399	118,5	117	8	+/- 2,5	43	134,1	227,9	
WNO441-610	415	160,8	81,5	441	135,5	131	8	+/- 2,5	45	149,8	279,5	
WNO441-711	415	157,8	81,5	441	135,5	131	8	+/- 2,5	45	164,7	294,3	
WNO441-812	415	151,8	81,5	441	135,5	131	8	+/- 2,5	45	196,8	326,4	
WNO441-915	415	151,8	81,5	441	135,5	131	8	+/- 2,5	45	227,2	356,8	

¹⁾ Assembly of brake disc optionally, standard combination GTW1, otherwise GTW2

²⁾ Attention on peak load – see chapter „RINGFEDER® TNM Basic information“ in Product Paper & Tech Paper „RINGFEDER® Elastomer Jaw Couplings“

³⁾ Set screw on demand

⁴⁾ Choose brake disc assembly in a way, that brake torque does not affect intermediate ring

To continue see next page

Elastomer Jaw Couplings RINGFEDER® TNM GTW

Explanation

A = Max. outer diameter	D₁ = Outer diameter	L₂ = Length on the hub
SB = Disc width	D₂ = Outer diameter hub	L₃ = Length
T_{KNPb72} = Coupling nominal torque by using the elastic element Pb72	D₄ = Outer diameter hub	E = Gap width between left and right component
T_{KNPb82} = Coupling nominal torque by using the elastic element Pb82	D₆ = Diameter	FE = Tolerance of the gap width E
T_{BR} = Brake torque	C₁ = Guided length in hub bore	EE = Distance of the hubs
n_{max} = Max. rotation speed	C₂ = Guided length in hub bore	GW_{BS} = Weight of part with brake disc, unbored
d_{1kmax} = Max. bore diameter d ₁ with keyway acc. to DIN 6885-1	C_{GTW1} = Distance, when using brake disc assembly GTW1	GW_{ub} = Weight, unbored
d_{2kmax} = Max. bore diameter d ₂ with keyway acc. to DIN 6885-1	C_{GTW2} = Distance, when using brake disc assembly GTW2	
	L = Total length	

Ordering example

Identifier	Size	d _{1k}	d _{2k}	Buffer identifier (optional) ⁵⁾	Further details
WN0419-406	194	80	62	Pb82	*

⁵⁾ Details on elastomer materials see chapter „Introduction“ and „RINGFEDER® TNM Basic information“ in Product Paper & Tech Paper „RINGFEDER® Elastomer Jaw Couplings“

⁷⁾ Without any other specification, we deliver as a standard: with set screws and keyway acc. to DIN 6885-1, keyway side fit P9, bore tolerance H7

Further information on
RINGFEDER® TNM GTW
 on www.ringfeder.com

Disclaimer of liability

All technical details and notes are non-binding and cannot be used as a basis for legal claims. The user is obligated to determine whether the represented products meet his requirements. We reserve the right carry out modifications at any time in the interests of technical progress.

Elastomer Jaw Couplings

RINGFEDER® TNM EBT

One part design with brake drum acc. to DIN 15431

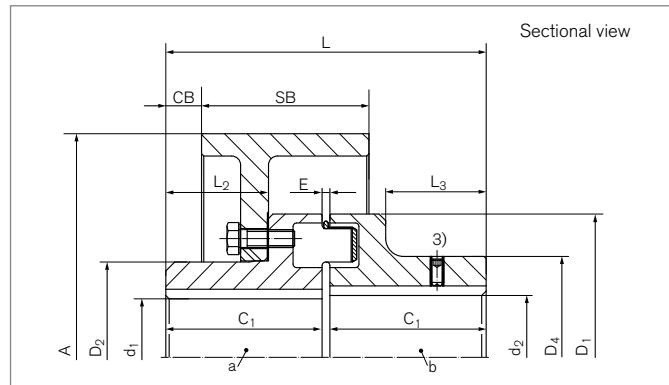
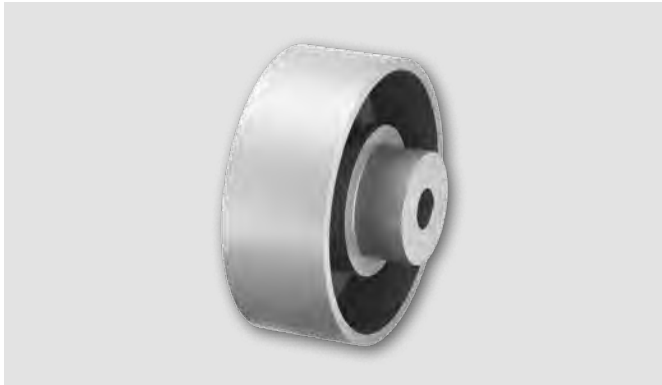

Identifier	Size	A	SB	$T_{KNP672}^{2)}$	$T_{KNP82}^{2)}$	$T_{BR}^{4)}$	n_{max}	d_{1kmax}	d_{2kmax}	D_1	D_2	D_4	C_1
		mm	mm	Nm	Nm	Nm	1/min	mm	mm	mm	mm	mm	mm
WNO511-200	112	200	75	150	230	450	4200	42	48	112	68	79	60
WNO512-200	128	200	75	250	380	550	4200	52	55	128	85	90	70
WNO514-250	148	250	95	390	600	1000	3400	58	65	148	94	107	80
WNO516-250	168	250	95	630	980	1600	3400	72	75	168	118	124	90
WNO516-315	168	315	118	630	980	1600	2700	72	75	168	118	124	90
WNO519-315	194	315	118	1050	1650	2750	2700	85	85	194	138	140	100
WNO521-315	214	315	118	1500	2400	3350	2700	92	95	214	153	157	110
WNO521-400	214	400	150	1500	2400	3350	2100	90	95	214	153	157	110
WNO524-400	240	400	150	2400	3700	4200	2100	102	110	240	168	179	120
WNO524-500	240	500	190	2400	3700	4200	1700	102	110	240	168	179	120
WNO526-500	265	500	190	3700	5800	8700	1700	120	120	265	198	198	140
WNO529-500	295	500	190	4900	7550	9800	1700	130	130	295	214	214	150
WNO529-630	295	630	236	4900	7550	9800	1360	130	130	295	214	214	150
WNO533-630	330	630	236	6400	9900	10600	1360	150	150	330	248	248	160
WNO533-710	330	710	265	6400	9900	10600	1200	150	150	330	248	248	160
WNO537-710	370	710	265	8900	14000	13500	1200	170	170	370	278	278	180
WNO541-710	415	710	265	13200	20500	16000	1200	185	190	415	308	315	200

To continue see next page

Elastomer Jaw Couplings RINGFEDER® TNM EBT

Identifier	Size	C _B	L	L ₂	L ₃	E	F _E	G _{WBS} ¹⁾	G _{Wub}
		mm	mm	mm	mm	mm	mm	kg	kg
WN0511-200	112	11	123,5	38,5	38	3,5	+/- 1,0	7,3	9,9
WN0512-200	128	16	143,5	45,5	45	3,5	+/- 1,0	8,9	13,0
WN0514-250	148	16	163,5	52,5	52	3,5	+/- 1,0	14,8	21,1
WN0516-250	168	19	183,5	56,5	56	3,5	+/- 1,5	18,1	27,7
WN0516-315	168	8	183,5	56,5	56	3,5	+/- 1,5	27,2	36,9
WN0519-315	194	16,5	203,5	62,5	62	3,5	+/- 1,5	30,8	44,7
WN0521-315	214	19	224	68,5	68	4	+/- 2,0	36,0	55,0
WN0521-400	214	12,5	224	68,5	68	4	+/- 2,0	51,7	70,8
WN0524-400	240	18	244	75,5	75	4	+/- 2,0	57,7	84,4
WN0524-500	240	9	244	75,5	75	4	+/- 2,0	84,5	111,4
WN0526-500	265	22	285,5	90,5	90	5,5	+/- 2,5	96,6	134,1
WN0529-500	295	30	308	98,5	98	8	+/- 2,5	106,0	153,9
WN0529-630	295	5	308	98,5	98	8	+/- 2,5	159,7	207,5
WN0533-630	330	11	328	104,5	104	8	+/- 2,5	176,7	243,1
WN0533-710	330	0	328	104,5	104	8	+/- 2,5	214,9	281,3
WN0537-710	370	15	368	118,5	118	8	+/- 2,5	242,3	366,2
WN0541-710	415	25	408	135,5	135	8	+/- 2,5	285,8	415,4

¹⁾ Weight inclusive the half share of the intermediate ring
²⁾ Attention on peak load – see chapter „RINGFEDER® TNM Basic information“ in Product Paper & Tech Paper „RINGFEDER® Elastomer Jaw Couplings“
³⁾ Set screw on demand
⁴⁾ Choose brake drum assembly in a way, that brake torque does not affect intermediate ring

Explanation

A = Max. outer diameter	d_{1kmax} = Max. bore diameter d ₁ with keyway acc. to DIN 6885-1	L = Total length
SB = Disc width	d_{2kmax} = Max. bore diameter d ₂ with keyway acc. to DIN 6885-1	L₂ = Length on the hub
T_{KNPb72} = Coupling nominal torque by using the elastic element Pb72	D₁ = Outer diameter	L₃ = Length
T_{KNPb82} = Coupling nominal torque by using the elastic element Pb82	D₂ = Outer diameter hub	E = Gap width between left and right component
T_{BR} = Brake torque	D₄ = Outer diameter hub	F_E = Tolerance of the gap width E
n_{max} = Max. rotation speed	C₁ = Guided length in hub bore	G_{WBS} = Weight of part with brake disc, unbored
	C_B = Brake disc distance	G_{Wub} = Weight, unbored

Ordering example

Identifier	Size	d _{1k}	d _{2k}	Buffer identifier (optional) ⁵⁾	Further details
WN0519-315	194	80	62	Pb82	*

Further information on RINGFEDER® TNM EBT on www.ringfeder.com

⁵⁾ Details on elastomer materials see chapter „Introduction“ and „RINGFEDER® TNM Basic information“ in Product Paper & Tech Paper „RINGFEDER® Elastomer Jaw Couplings“

⁶⁾ Without any other specification, we deliver as a standard: with set screws and keyway acc. to DIN 6885-1, keyway side fit P9, bore tolerance H7

Disclaimer of liability

All technical details and notes are non-binding and cannot be used as a basis for legal claims. The user is obligated to determine whether the represented products meet his requirements. We reserve the right carry out modifications at any time in the interests of technical progress.

Elastomer Jaw Couplings

RINGFEDER® TNM GBT

Multi-part design, to change the intermediate ring without axial movement of the driven parts with brake drum acc. to DIN 15431

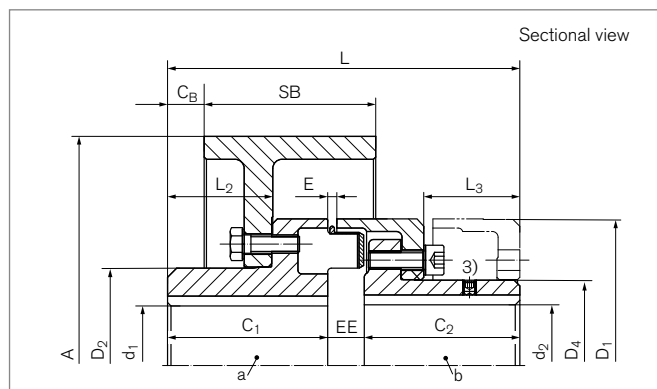
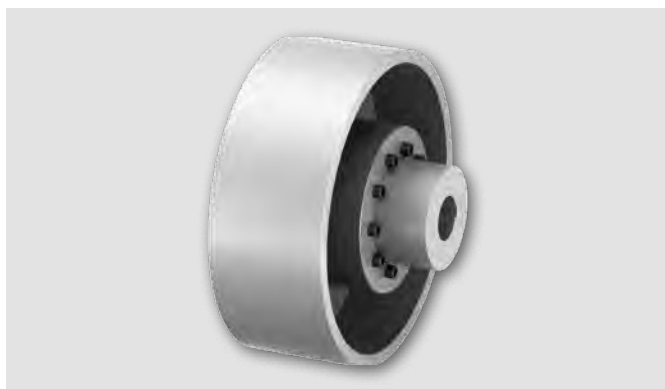

Identifier	Size	A	SB	T _{KNPb72} ²⁾	T _{KNPb82} ²⁾	T _{BR} ⁴⁾	n _{max}	d _{1kmax}	d _{2kmax}	D ₁	D ₂	D ₄	C ₁	C ₂
		mm	mm	Nm	Nm	Nm	1/min	mm	mm	mm	mm	mm	mm	mm
WN0611-200	112	200	75	150	230	450	4200	42	46	112	68	64,5	60	58
WN0612-200	128	200	75	250	380	550	4200	52	53	128	85	74,5	70	68
WN0614-250	148	250	95	390	600	1000	3400	58	65	148	94	92,5	80	78
WN0616-250	168	250	95	630	980	1600	3400	72	75	168	118	104,5	90	87
WN0616-315	168	315	118	630	980	1600	2700	72	75	168	118	104,5	90	87
WN0619-315	194	315	118	1050	1650	2750	2700	85	85	194	138	121,5	100	97
WN0621-315	214	315	118	1500	2400	3350	2700	92	95	214	153	135,5	110	107
WN0621-400	214	400	150	1500	2400	3350	2100	92	95	214	153	135,5	110	107
WN0624-400	240	400	150	2400	3700	4200	2100	102	100	240	168	146	120	117
WN0624-500	240	500	190	2400	3700	4200	1700	102	100	240	168	146	120	117
WN0626-500	265	500	190	3700	5800	8700	1700	120	115	265	198	164	140	137
WN0629-500	295	500	190	4900	7550	9800	1700	130	130	295	214	181	150	147
WN0629-630	295	630	236	4900	7550	9800	1360	130	130	295	214	181	150	147
WN0633-630	330	630	236	6400	9900	10600	1360	150	135	330	248	208	160	156
WN0633-710	330	710	265	6400	9900	10600	1200	150	135	330	248	208	160	156
WN0637-710	370	710	265	8900	14000	13500	1200	170	160	370	278	241	180	176
WN0641-710	415	710	265	13200	20500	16000	1200	185	180	415	308	275	200	196

To continue see next page

Elastomer Jaw Couplings RINGFEDER® TNM GBT

Identifier	Size	C _B	L	L ₂	L ₃	E	F _E	EE	G _{WBS} ¹⁾	G _{Wub}
		mm	mm	mm	mm	mm	mm	mm	kg	kg
WNO611-200	112	11	133	38,5	32,5	3,5	+/- 1,0	15	7,3	10,2
WNO612-200	128	16	154	45,5	42	3,5	+/- 1,0	16	8,9	13,0
WNO614-250	148	16	176	52,5	47	3,5	+/- 1,0	18	14,8	21,5
WNO616-250	168	19	198	56,5	52,5	3,5	+/- 1,5	21	18,1	17,8
WNO616-315	168	8	198	56,5	52,5	3,5	+/- 1,5	21	27,2	37,0
WNO619-315	194	16,5	221	62,5	60	3,5	+/- 1,5	24	30,8	45,4
WNO621-315	214	19	243	68,5	66,5	4	+/- 2,0	26	36,0	55,6
WNO621-400	214	12,5	243	68,5	66,5	4	+/- 2,0	26	51,7	71,4
WNO624-400	240	18	267	75,5	75,5	4	+/- 2,0	30	57,7	83,5
WNO624-500	240	9	267	75,5	75,5	4	+/- 2,0	30	84,5	110,5
WNO626-500	265	22	310	90,5	89	5,5	+/- 2,5	33	96,6	134,4
WNO629-500	295	30	334	98,5	96	8	+/- 2,5	37	106,0	155,5
WNO629-630	295	5	334	98,5	96	8	+/- 2,5	37	159,7	209,1
WNO633-630	330	11	356	104,5	101,5	8	+/- 2,5	40	176,7	240,2
WNO633-710	330	0	356	104,5	101,5	8	+/- 2,5	40	214,9	278,3
WNO637-710	370	15	399	118,5	117	8	+/- 2,5	43	242,3	332,0
WNO641-710	415	25	441	135,5	131	8	+/- 2,5	45	285,8	414,3

1) Weight inclusive the half share of the intermediate ring
 2) Attention on peak load – see chapter „RINGFEDER® TNM Basic information“ in Product Paper & Tech Paper „RINGFEDER® Elastomer Jaw Couplings“
 3) Set screw on demand
 4) Choose brake drum assembly in a way, that brake torque does not affect intermediate ring

Explanation

A = Max. outer diameter	d_{2kmax} = Max. bore diameter d ₂ with keyway acc. to DIN 6885-1	L₂ = Length on the hub
SB = Disc width	D₁ = Outer diameter	L₃ = Length
T_{KNPb72} = Coupling nominal torque by using the elastic element Pb72	D₂ = Outer diameter hub	E = Gap width between left and right component
T_{KNPb82} = Coupling nominal torque by using the elastic element Pb82	D₄ = Outer diameter hub	F_E = Tolerance of the gap width E
T_{BR} = Brake torque	C₁ = Guided length in hub bore	EE = Distance of the hubs
n_{max} = Max. rotation speed	C₂ = Guided length in hub bore	G_{WBS} = Weight of part with brake disc, unbored
d_{1kmax} = Max. bore diameter d ₁ with keyway acc. to DIN 6885-1	C_B = Brake disc distance	G_{Wub} = Weight, unbored
	L = Total length	

Ordering example

Identifier	Size	d _{1k}	d _{2k}	Buffer identifier (optional) ⁵⁾	Further details
WNO619-315	194	80	62	Pb82	*

Further information on RINGFEDER® TNM GBT on www.ringfeder.com

5) Details on elastomer materials see chapter „Introduction“ and „RINGFEDER® TNM Basic information“ in Product Paper & Tech Paper „RINGFEDER® Elastomer Jaw Couplings“

7) Without any other specification, we deliver as a standard: with set screws and keyway acc. to DIN 6885-1, keyway side fit P9, bore tolerance H7

Disclaimer of liability

All technical details and notes are non-binding and cannot be used as a basis for legal claims. The user is obligated to determine whether the represented products meet his requirements. We reserve the right carry out modifications at any time in the interests of technical progress.

Elastomer Jaw Couplings

RINGFEDER® TNM H

Multi-part design, to remove the intermediate spacer.
 Disassembly of the pump impeller without axial movement
 of the driven parts

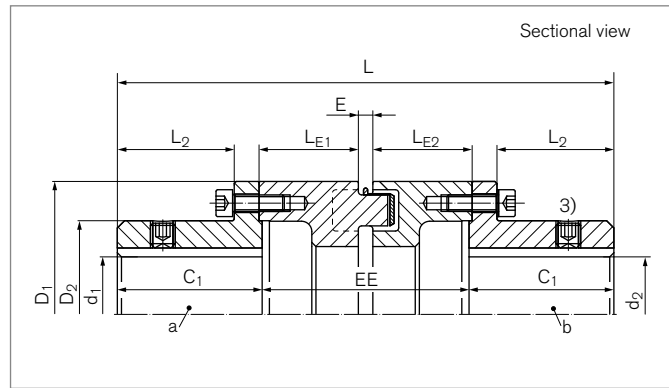

Identifier	Size	$T_{KNPb72}^{2)}$	$T_{KNPb82}^{2)}$	n_{max}	d_{1kmax}	d_{2kmax}	D_1	D_2	C_1
		Nm	Nm	1/min	mm	mm	mm	mm	mm
WN0706-100	67	22	35	5000	30	30	67	45	30
WN0706-120	67	22	35	5000	30	30	67	45	30
WN0706-140	67	22	35	5000	30	30	67	45	30
WN0708-100	82	48	75	5000	35	35	82	53	40
WN0708-120	82	48	75	5000	35	35	82	53	40
WN0708-140	82	48	75	5000	35	35	82	53	40
WN0709-100	97	96	150	5000	45	45	97	66	50
WN0709-120	97	96	150	5000	45	45	97	66	50
WN0709-140	97	96	150	5000	45	45	97	66	50
WN0711-100	112	150	230	5000	50	50	112	79	60
WN0711-120	112	150	230	5000	50	50	112	79	60
WN0711-140	112	150	230	5000	50	50	112	79	60
WN0712-100	128	250	380	5000	60	60	128	90	70
WN0712-120	128	250	380	5000	60	60	128	90	70
WN0712-140	128	250	380	5000	60	60	128	90	70
WN0712-180	128	250	380	5000	60	60	128	90	70
WN0714-100	148	390	600	4500	65	65	148	107	80
WN0714-140	148	390	600	4500	65	65	148	107	80
WN0714-180	148	390	600	4500	65	65	148	107	80
WN0716-100	168	630	980	4000	75	75	168	124	90
WN0716-140	168	630	980	4000	75	75	168	124	90
WN0716-180	168	630	980	4000	75	75	168	124	90
WN0719-100	194	1050	1650	3500	85	85	194	140	100
WN0719-140	194	1050	1650	3500	85	85	194	140	100
WN0719-180	194	1050	1650	3500	85	85	194	140	100
WN0719-250	194	1050	1650	3500	85	85	194	140	100
WN0721-100	214	1500	2400	3000	95	95	214	157	110

To continue see next page

Elastomer Jaw Couplings RINGFEDER® TNM H

Identifier	Size	T _{KNPb72} ²⁾	T _{KNPb82} ²⁾	n _{max}	d _{1kmax}	d _{2kmax}	D ₁	D ₂	C ₁
		Nm	Nm	1/min	mm	mm	mm	mm	mm
WN0721-140	214	1500	2400	3000	95	95	214	157	110
WN0721-180	214	1500	2400	3000	95	95	214	157	110
WN0721-250	214	1500	2400	3000	95	95	214	157	110
WN0724-100	240	2400	3700	2750	110	110	240	179	120
WN0724-140	240	2400	3700	2750	110	110	240	179	120
WN0724-180	240	2400	3700	2750	110	110	240	179	120
WN0724-250	240	2400	3700	2750	110	110	240	179	120
WN0726-100	265	3700	5800	2500	120	120	265	198	140
WN0726-140	265	3700	5800	2500	120	120	265	198	140
WN0726-180	265	3700	5800	2500	120	120	265	198	140
WN0726-250	265	3700	5800	2500	120	120	265	198	140
WN0729-140	295	4900	7550	2250	130	130	295	214	150
WN0729-180	295	4900	7550	2250	130	130	295	214	150
WN0729-250	295	4900	7550	2250	130	130	295	214	150
WN0733-140	330	6400	9900	2000	150	150	330	248	160
WN0733-180	330	6400	9900	2000	150	150	330	248	160
WN0733-250	330	6400	9900	2000	150	150	330	248	160

Identifier	Size	L	L ₂	L _{E1}	L _{E2}	E	F _E	EE	GW _{ZW}	GW _{ub}
		mm	mm	mm	mm	mm	mm	mm	kg	kg
WN0706-100	67	160	20	48,5	48,5	5	+/- 0,5	100	1,4	2,5
WN0706-120	67	180	20	48,5	68,5	5	+/- 0,5	120	1,7	2,8
WN0706-140	67	200	20	68,5	68,5	5	+/- 0,5	140	2,0	3,1
WN0708-100	82	180	28	48,5	48,5	5	+/- 1,0	100	2,0	4,0
WN0708-120	82	200	28	48,5	68,5	5	+/- 1,0	120	2,4	4,0
WN0708-140	82	220	28	68,5	68,5	5	+/- 1,0	140	2,8	4,9
WN0709-100	97	200	37	48,5	48,5	5	+/- 1,0	100	2,8	6,4
WN0709-120	97	220	37	48,5	68,5	5	+/- 1,0	120	3,5	7,0
WN0709-140	97	240	37	68,5	68,5	5	+/- 1,0	140	4,1	7,7
WN0711-100	112	220	46,5	48	48	7	+/- 1,0	100	3,8	9,5
WN0711-120	112	240	46,5	48	68	7	+/- 1,0	120	4,6	10,3
WN0711-140	112	260	46,5	68	68	7	+/- 1,0	140	5,4	11,1
WN0712-100	128	240	56,5	48	48	7	+/- 1,0	100	4,8	13,2
WN0712-120	128	260	56,5	48	68	7	+/- 1,0	120	5,8	14,2
WN0712-140	128	280	56,5	68	68	7	+/- 1,0	140	6,7	15,1
WN0712-180	128	320	56,5	88	88	7	+/- 1,0	180	8,6	17,0
WN0714-100	148	260	64,5	48	48	7	+/- 1,0	100	6,0	18,4
WN0714-140	148	300	64,5	48	88	7	+/- 1,0	140	8,4	20,8
WN0714-180	148	340	64,5	88	88	7	+/- 1,0	180	10,8	23,3
WN0716-100	168	280	73,5	48	48	7	+/- 1,5	100	7,6	26,0
WN0716-140	168	320	73,5	48	88	7	+/- 1,5	140	10,5	28,9
WN0716-180	168	360	73,5	88	88	7	+/- 1,5	180	13,3	31,8
WN0719-100	194	300	82,5	48	48	7	+/- 1,5	100	9,4	35,7
WN0719-140	194	340	82,5	48	88	7	+/- 1,5	140	12,9	39,1
WN0719-180	194	380	82,5	88	88	7	+/- 1,5	180	16,3	42,6
WN0719-250	194	450	82,5	123	123	7	+/- 1,5	250	22,4	48,7
WN0721-100	214	320	90,5	48	48	7	+/- 1,5	100	11,5	47,6
WN0721-140	214	360	90,5	48	88	7	+/- 1,5	140	15,7	51,8
WN0721-180	214	400	90,5	88	88	7	+/- 1,5	180	19,9	56,0
WN0721-250	214	470	90,5	123	123	7	+/- 1,5	250	27,2	63,3

To continue see next page

Elastomer Jaw Couplings RINGFEDER® TNM H

Identifier	Size	L	L ₂	LE ₁	LE ₂	E	F _E	EE	G _{wz}	G _{wub}
		mm	mm	mm	mm	mm	mm	mm	kg	kg
WN0724-100	240	340	98	48	48	8	+/- 1,5	100	15,8	66,5
WN0724-140	240	380	98	48	88	8	+/- 1,5	140	19,9	70,6
WN0724-180	240	420	98	88	88	8	+/- 1,5	180	24,0	74,7
WN0724-250	240	490	98	123	123	8	+/- 1,5	250	31,8	82,5
WN0726-100	265	380	117	48	48	8	+/- 1,5	100	19,6	91,1
WN0726-140	265	420	117	48	88	8	+/- 1,5	140	23,6	95,1
WN0726-180	265	460	117	88	88	8	+/- 1,5	180	27,6	99,1
WN0726-250	265	530	117	123	123	8	+/- 1,5	250	38,0	109,5
WN0729-140	295	440	122	67	67	10	+/- 2,5	140	31,2	123,5
WN0729-180	295	480	122	87	87	10	+/- 2,5	180	37,9	130,2
WN0729-250	295	550	122	122	122	10	+/- 2,5	250	47,9	140,2
WN0733-140	330	460	128	67	67	10	+/- 2,5	140	40,9	171,7
WN0733-180	330	500	128	87	87	10	+/- 2,5	180	49,7	180,5
WN0733-250	330	570	128	122	122	10	+/- 2,5	250	64,5	195,3

¹⁾ Mass information for unbored coupling parts

²⁾ Attention on peak load – see chapter „RINGFEDER® TNM Basic information“ in Product Paper & Tech Paper „RINGFEDER® Elastomer Jaw Couplings“

³⁾ Set screw on demand

Explanation

T_{KNPb72} = Coupling nominal torque by using the elastic element Pb72	D₁ = Outer diameter	F_E = Tolerance of the gap width E
T_{KNPb82} = Coupling nominal torque by using the elastic element Pb82	D₂ = Outer diameter hub	EE = Distance of the hubs
n_{max} = Max. rotation speed	C₁ = Guided length in hub bore	G_{wz} = Spacer weight
d_{1kmax} = Max. bore diameter d ₁ with keyway acc. to DIN 6885-1	L = Total length	G_{wub} = Weight, unbored
d_{2kmax} = Max. bore diameter d ₂ with keyway acc. to DIN 6885-1	L₂ = Length on the hub	
	LE₁ = Spacer Length	
	LE₂ = Spacer Length	
	E = Gap width between left and right component	

Ordering example

Identifier	Size	d _{1k}	d _{2k}	Buffer identifier (optional) ⁴⁾	Further details
WN0714-180	148	65	50	Pb82	*

⁴⁾ Details on elastomer materials see chapter „Introduction“ and „RINGFEDER® TNM Basic information“ in Product Paper & Tech Paper „RINGFEDER® Elastomer Jaw Couplings“

⁵⁾ Without any other specification, we deliver as a standard: with set screws and keyway acc. to DIN 6885-1, keyway side fit P9, bore tolerance H7

Further information on
RINGFEDER® TNM H
 on www.ringfeder.com

Disclaimer of liability

All technical details and notes are non-binding and cannot be used as a basis for legal claims. The user is obligated to determine whether the represented products meet his requirements. We reserve the right carry out modifications at any time in the interests of technical progress.

Elastomer Jaw Couplings

RINGFEDER® TNM LE

One part design with flange, externally centred

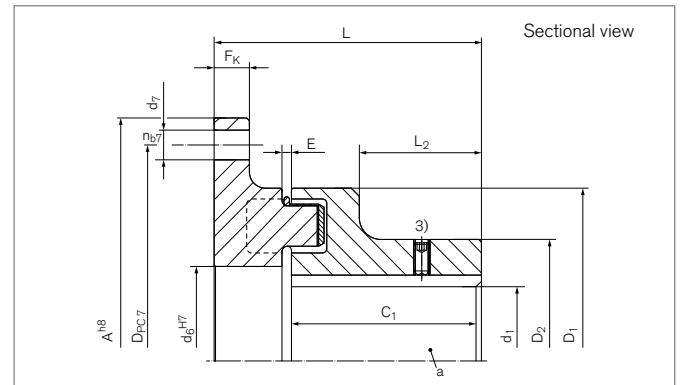

Identifier	Size	A ⁴⁾	T _{KNPb72} ²⁾	T _{KNPb82} ²⁾	n _{max}	d _{1kmax}	D ₁	D ₂	C ₁
		mm	Nm	Nm	1/min	mm	mm	mm	mm
WN0806-106	67	106	22	35	5000	28	67	46	30
WN0808-120	82	120	48	75	5000	32	82	53	40
WN0809-144	97	144	96	150	5000	45	97	69	50
WN0811-158	112	158	150	230	5000	48	112	79	60
WN0812-180	128	180	250	380	5000	55	128	90	70
WN0814-200	148	200	390	600	4500	65	148	107	80
WN0816-220	168	220	630	980	4000	75	168	124	90
WN0819-248	194	248	1050	1650	3500	85	194	140	100
WN0821-274	214	274	1500	2400	3000	95	214	157	110
WN0824-314	240	314	2400	3700	2750	110	240	179	120
WN0826-344	265	344	3700	5800	2500	120	265	198	140
WN0829-380	295	380	4900	7550	2250	130	295	214	150
WN0833-430	330	430	6400	9900	2000	150	330	248	160
WN0837-480	370	480	8900	14000	1750	170	370	278	180
WN0841-575	415	575	13200	20500	1500	190	415	315	200
WN0848-615	480	615	18000	28000	1400	210	480	315	220
WN0857-692	575	692	27000	41000	1200	230	575	350	240

To continue see next page

Elastomer Jaw Couplings RINGFEDER® TNM LE

Identifier	Size	F _K	d ₆	D _{PC7}	n _{b7}	d ₇	L	L ₂	E	F _E	GW _{FL} ¹⁾	GW _{ub}
		mm	mm	mm		mm	mm	mm	mm	mm	kg	kg
WN0806-106	67	8	30	94	6	6,6	47,5	15	2,5	+/- 0,5	0,5	1,0
WN0808-120	82	8	40	108	6	6,6	59	24	3	+/- 1,0	0,7	2,6
WN0809-144	97	10	50	128	6	9	73	30	3	+/- 1,0	1,2	2,9
WN0811-158	112	10	60	142	6	9	85,5	38	3,5	+/- 1,0	1,6	4,2
WN0812-180	128	13	70	160	6	11	98,5	45	3,5	+/- 1,0	2,5	6,6
WN0814-200	148	13	90	180	7	11	111,5	52	3,5	+/- 1,0	3,1	9,4
WN0816-220	168	13	100	200	8	11	127,5	56	3,5	+/- 1,5	4,3	13,9
WN0819-248	194	16	115	224	8	14	141,5	62	3,5	+/- 1,5	6,3	20,3
WN0821-274	214	16	130	250	8	14	156	68	4	+/- 2,0	8,2	27,9
WN0824-314	240	20	145	282	8	18	169	75	4	+/- 2,0	11,8	38,5
WN0826-344	265	20	160	312	8	18	195,5	90	5,5	+/- 2,5	15,6	53,1
WN0829-380	295	22	170	348	9	18	210	98	8	+/- 2,5	20,7	68,6
WN0833-430	330	25	200	390	9	22	224	104	8	+/- 2,5	28,1	94,6
WN0837-480	370	25	235	440	10	22	250	118	8	+/- 2,5	36,2	130,1
WN0841-575	415	30	270	528	10	26	273	135	8	+/- 2,5	55,4	185,1
WN0848-615	480	30	320	568	10	26	293	150	8	+/- 2,5	62,4	226,8
WN0857-692	575	30	400	645	10	26	313	170	8	+/- 2,5	74,7	308,2

¹⁾ Weight inclusive the half share of the intermediate ring

RINGFEDER® TNM with SAE flange on request

²⁾ Attention on peak load – see chapter „RINGFEDER® TNM Basic information“ in Product Paper & Tech Paper

„RINGFEDER® Elastomer Jaw Couplings“

³⁾ Set screw on demand

⁴⁾ Other flange dimensions on request

Explanation

A = Max. outer diameter	D₁ = Outer diameter	L = Total length
T_{KNPb72} = Coupling nominal torque by using the elastic element Pb72	D₂ = Outer diameter hub	L₂ = Length on the hub
T_{KNPb82} = Coupling nominal torque by using the elastic element Pb82	C₁ = Guided length in hub bore	E = Gap width between left and right component
n_{max} = Max. rotation speed	F_K = Flange thickness	F_E = Tolerance of the gap width E
d_{1kmax} = Max. bore diameter d ₁ with keyway acc. to DIN 6885-1	d₆ = Inner diameter	GW_{FL} = Weight flange side
	D_{PC7} = Pitch circle diameter of bore holes d ₇	GW_{ub} = Weight, unbored
	n_{b7} = Quantity of bore d ₇	
	d₇ = Bore diameter	

Ordering example

Identifier	Size	d _{1k}	Buffer identifier (optional) ⁵⁾	Further details
WN0819-248	148	80	Pb82	*

Further information on RINGFEDER® TNM LE on www.ringfeder.com

⁵⁾ Details on elastomer materials see chapter „Introduction“ and „RINGFEDER® TNM Basic information“ in Product Paper & Tech Paper „RINGFEDER® Elastomer Jaw Couplings“

⁷⁾ Without any other specification, we deliver as a standard: with set screws and keyway acc. to DIN 6885-1, keyway side fit P9, bore tolerance H7

Disclaimer of liability

All technical details and notes are non-binding and cannot be used as a basis for legal claims. The user is obligated to determine whether the represented products meet his requirements. We reserve the right carry out modifications at any time in the interests of technical progress.

Elastomer Jaw Couplings

RINGFEDER® TNM LG

Multi-part design, to change the intermediate ring without axial movement of the driven parts with flange, externally centred

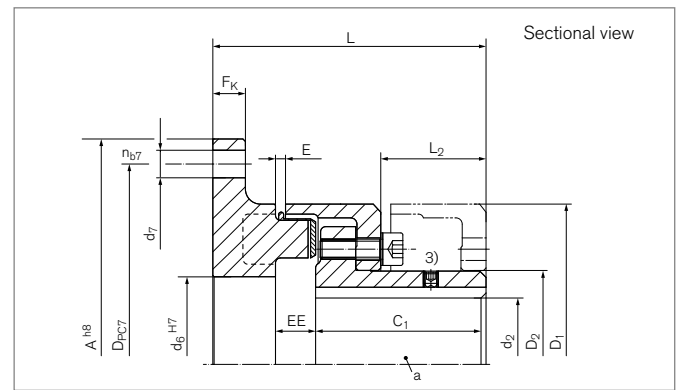

Identifier	Size	A ⁴⁾	T _{KNPb72} ²⁾	T _{KNPb82} ²⁾	n _{max}	d _{1kmax}	D ₁	D ₂	C ₁
		mm	Nm	Nm	1/min	mm	mm	mm	mm
WN0908-120	82	120	48	75	5000	32	82	44,5	40
WN0909-144	97	144	96	150	5000	39	97	54,5	49
WN0911-158	112	158	150	230	5000	46	112	64,5	58
WN0912-180	128	180	250	380	5000	53	128	74,5	68
WN0914-200	148	200	390	600	4500	65	148	92,5	78
WN0916-220	168	220	630	980	4000	75	168	104,5	87
WN0919-248	194	248	1050	1650	3500	85	194	121,5	97
WN0921-274	214	274	1500	2400	3000	95	214	135,5	107
WN0924-314	240	314	2400	3700	2750	100	240	146	117
WN0926-344	265	344	3700	5800	2500	115	265	164	137
WN0929-380	295	380	4900	7550	2250	130	295	181	147
WN0933-430	330	430	6400	9900	2000	135	330	208	156
WN0937-480	370	480	8900	14000	1750	160	370	241	176
WN0941-575	415	575	13200	20500	1500	180	415	275	196
WN0948-615	480	615	18000	28000	1400	200	480	289	220
WN0957-692	575	692	27000	41000	1200	260	575	368	240

To continue see next page

Elastomer Jaw Couplings RINGFEDER® TNM LG

Identifier	Size	F _K	d ₆	D _{PC7}	n _{b7}	d ₇	L	L ₂	E	F _E	G _{WFL} ¹⁾	G _{Wub}
		mm	mm	mm		mm	mm	mm	mm	mm	kg	kg
WN0908-120	82	8	40	108	6	6,6	68	20	3	+/- 1,0	0,7	1,8
WN0909-144	97	10	50	128	6	9	83	30,5	3	+/- 1,0	1,2	2,9
WN0911-158	112	10	60	142	6	9	95	32,5	3,5	+/- 1,0	1,6	4,4
WN0912-180	128	13	70	160	6	11	109	42	3,5	+/- 1,0	2,5	6,7
WN0914-200	148	13	90	180	7	11	124	47	3,5	+/- 1,0	3,1	9,8
WN0916-220	168	13	100	200	8	11	142	52,5	3,5	+/- 1,5	4,3	14,0
WN0919-248	194	16	115	224	8	14	159	60	3,5	+/- 1,5	6,3	21,0
WN0921-274	214	16	130	250	8	14	175	66,5	4	+/- 2,0	8,2	27,9
WN0924-314	240	20	145	282	8	18	192	75,5	4	+/- 2,0	11,8	37,6
WN0926-344	265	20	160	312	8	18	220	88	5,5	+/- 2,5	15,6	53,4
WN0929-380	295	22	170	348	9	18	236	96	8	+/- 2,5	20,7	70,2
WN0933-430	330	25	200	390	9	22	252	101,5	8	+/- 2,5	28,1	91,7
WN0937-480	370	25	235	440	10	22	281	117	8	+/- 2,5	36,2	126,0
WN0941-575	415	30	270	528	10	26	306	131	8	+/- 2,5	55,4	183,9
WN0948-615	480	30	320	568	10	26	330	149	8	+/- 2,5	62,4	244,7
WN0957-692	575	30	400	645	10	26	350	168	8	+/- 2,5	74,7	370,1

¹⁾ Weight inclusive the half share of the intermediate ring

RINGFEDER® TNM with SAE flange on request

²⁾ Attention on peak load – see chapter „RINGFEDER® TNM Basic information“ in Product Paper & Tech Paper „RINGFEDER® Elastomer Jaw Couplings“

³⁾ Set screw on demand

⁴⁾ Other flange dimensions on request

Explanation

A = Max. outer diameter	D₂ = Outer diameter hub	E = Gap width between left and right component
T_{KNPb72} = Coupling nominal torque by using the elastic element Pb72	C₁ = Guided length in hub bore	F_E = Tolerance of the gap width E
T_{KNPb82} = Coupling nominal torque by using the elastic element Pb82	F_K = Flange thickness	EE = Distance of the hubs
n_{max} = Max. rotation speed	d₆ = Inner diameter	G_{WFL} = Weight flange side
d_{1kmax} = Max. bore diameter d ₁ with keyway acc. to DIN 6885-1	D_{PC7} = Pitch circle diameter of bore holes d ₇	G_{Wub} = Weight, unbored
D₁ = Outer diameter	n_{b7} = Quantity of bore d ₇	
	d₇ = Bore diameter	
	L = Total length	
	L₂ = Length on the hub	

Ordering example

Identifier	Size	d _{1k}	Buffer identifier (optional) ⁵⁾	Further details
WN0919-248	194	80	Pb82	*

Further information on RINGFEDER® TNM LG on www.ringfeder.com

⁵⁾ Details on elastomer materials see chapter „Introduction“ and „RINGFEDER® TNM Basic information“ in Product Paper & Tech Paper „RINGFEDER® Elastomer Jaw Couplings“

⁶⁾ Without any other specification, we deliver as a standard: with set screws and keyway acc. to DIN 6885-1, keyway side fit P9, bore tolerance H7

Disclaimer of liability

All technical details and notes are non-binding and cannot be used as a basis for legal claims. The user is obligated to determine whether the represented products meet his requirements. We reserve the right carry out modifications at any time in the interests of technical progress.

Elastomer Jaw Couplings

RINGFEDER® TNM GHBS

With brake disc in steel, multi-part design, to change the intermediate ring and the brake disc without axial movement of the driven parts

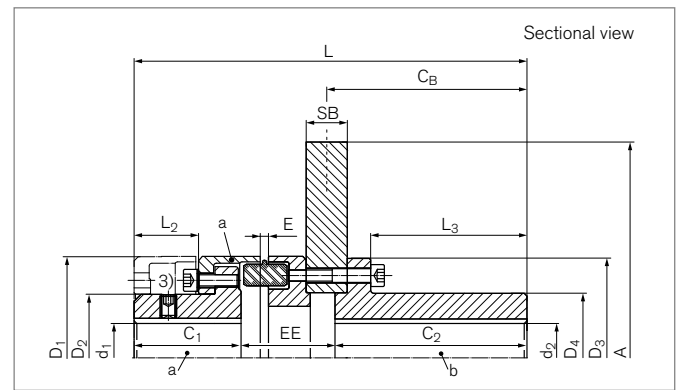

Identifier	Size	A	SB	T _{KNPb72} ²⁾	T _{KNPb82} ²⁾	T _{BR} ⁴⁾	n _{max}	d _{1kmax}	d _{2kmax}	D ₁	D ₂	D ₃	D ₄	C ₁	C ₂
		mm	mm	Nm	Nm	Nm	1/min	mm	mm	mm	mm	mm	mm	mm	mm
WN1514-315	148	315	30	390	600	1000	4500	65	65	148	92,5	145	94	78	140
WN1516-355	168	355	30	630	980	1600	4000	75	80	168	104,5	168	115	87	140
WN1516-400	168	400	30	630	980	1600	4000	75	80	168	104,5	168	115	87	140
WN1516-450	168	450	30	630	980	1600	3750	75	80	168	104,5	168	115	87	140
WN1519-400	194	400	30	1050	1650	2750	3500	85	95	194	121,5	194	135	97	140
WN1519-560	194	560	30	1050	1650	2750	3000	85	95	194	121,5	194	135	97	140
WN1524-450	240	450	30	2400	3700	4200	2750	100	115	240	146	225	165	117	140
WN1524-560	240	560	30	2400	3700	4200	2750	100	115	240	146	225	165	117	140
WN1524-630	240	630	30	2400	3700	4200	2750	100	115	240	146	225	165	117	140
WN1526-500	265	500	30	3700	5800	8700	2500	115	135	265	164	265	195	137	140
WN1526-560	265	560	30	3700	5800	8700	2500	115	135	265	164	265	195	137	140
WN1526-710	265	710	30	3700	5800	8700	2400	115	135	265	164	265	195	137	140
WN1529-630	295	630	30	4900	7550	9800	2250	130	153	295	181	295	215	147	140
WN1529-710	295	710	30	4900	7550	9800	2250	130	153	295	181	295	215	147	140

To continue see next page

Elastomer Jaw Couplings RINGFEDER® TNM GHBS

Identifier	Size	C _B	L	L ₂	L ₃	E	F _E	EE	G _{wa} ¹⁾	G _{wub}
		mm	mm	mm	mm	mm	mm	mm	kg	kg
WN1514-315	148	146	286,5	47	119	6	+/- 1,0	68,5	6,7	34
WN1516-355	168	146	304,5	52,5	116	6	+/- 1,5	77,5	9,7	46
WN1516-400	168	146	304,5	52,5	116	6	+/- 1,5	77,5	9,7	52
WN1516-450	168	146	304,5	52,5	116	6	+/- 1,5	77,5	9,7	60
WN1519-400	194	146	321,5	60	112	6	+/- 1,5	84,5	14,6	63
WN1519-560	194	146	321,5	60	112	6	+/- 1,5	84,5	14,6	91
WN1524-450	240	146	354	75,5	109,5	6,5	+/- 2,0	97	25,7	92
WN1524-560	240	146	354	75,5	109,5	6,5	+/- 2,0	97	25,7	113
WN1524-630	240	146	354	75,5	109,5	6,5	+/- 2,0	97	25,7	128
WN1526-500	265	146	381,5	88	107	7	+/- 2,0	104,5	37,8	125
WN1526-560	265	146	381,5	88	107	7	+/- 2,0	104,5	37,8	137
WN1526-710	265	146	381,5	88	107	7	+/- 2,0	104,5	37,8	172
WN1529-630	295	146	396,5	96	106	8	+/- 2,0	109,5	49,3	175
WN1529-710	295	146	396,5	96	106	8	+/- 2,0	109,5	49,3	194

¹⁾ Weight inclusive the half share of the intermediate ring

²⁾ Attention on peak load – see chapter „RINGFEDER® TNM Basic information“ in Product Paper & Tech Paper „RINGFEDER® Elastomer Jaw Couplings“

³⁾ Set screw on demand

⁴⁾ Choose brake disc assembly in a way, that brake torque does not affect intermediate ring

Explanation

A = Max. outer diameter	d_{2kmax} = Max. bore diameter d ₂ with keyway acc. to DIN 6885-1	L₂ = Length on the hub
SB = Disc width	D₁ = Outer diameter	L₃ = Length
T_{KNPb72} = Coupling nominal torque by using the elastic element Pb72	D₂ = Outer diameter hub	E = Gap width between left and right component
T_{KNPb82} = Coupling nominal torque by using the elastic element Pb82	D₃ = Outer diameter hub	F_E = Tolerance of the gap width E
T_{BR} = Brake torque	D₄ = Outer diameter hub	EE = Distance of the hubs
n_{max} = Max. rotation speed	C₁ = Guided length in hub bore	G_{wa} = Weight of subassembly a
d_{1kmax} = Max. bore diameter d ₁ with keyway acc. to DIN 6885-1	C₂ = Guided length in hub bore	G_{wub} = Weight, unbored
	C_B = Brake disc distance	
	L = Total length	

Ordering example

Identifier	Size	d _{1k}	d _{2k}	Buffer identifier (optional) ⁵⁾	Further details
WN1519-560	194	80	62	Pb82	*

Further information on
RINGFEDER® TNM GHBS
 on www.ringfeder.com

⁵⁾ Details on elastomer materials see chapter „Introduction“ and „RINGFEDER® TNM Basic information“ in Product Paper & Tech Paper „RINGFEDER® Elastomer Jaw Couplings“

⁷⁾ Without any other specification, we deliver as a standard: with set screws and keyway acc. to DIN 6885-1, keyway side fit P9, bore tolerance H7

Disclaimer of liability

All technical details and notes are non-binding and cannot be used as a basis for legal claims. The user is obligated to determine whether the represented products meet his requirements. We reserve the right carry out modifications at any time in the interests of technical progress.

Elastomer Jaw Couplings

RINGFEDER® TNS S-St

Coupling with standard hubs

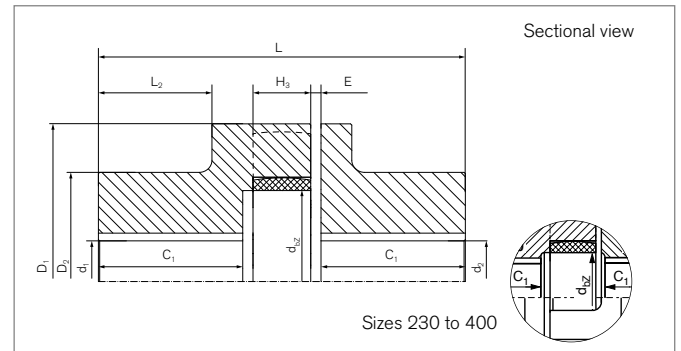

Identifier	Size	T _{KN}	T _{KNmax}	n _{max}	d _{1kmax}	d _{2kmax}	D ₁	D ₂	C ₁
		Nm	Nm	1/min	mm	mm	mm	mm	mm
WS0105	50	15	40	15000	25	25	50	41	30
WS0107	70	55	160	11000	38	38	70	55	38,5
WS0108	85	75	225	9000	40	40	85	60	43,5
WS0110	100	130	390	7250	48	48	105	75	49,5
WS0112	125	250	750	6000	55	55	126	85	56,5
WS0114	145	400	1200	5250	65	65	145	95	61
WS0117	170	630	1900	4500	85	85	170	120	75
WS0120	200	1100	3300	3750	95	95	200	135	99
WS0123	230	1700	5150	3250	105	105	230	150	110
WS0126	260	2650	7950	3000	125	125	260	180	112,5
WS0130	300	3900	11700	2500	140	140	300	200	131,5
WS0136	360	6500	19500	2150	150	150	360	210	172
WS0140	400	8900	26700	1900	160	160	400	225	163,5

Identifier	Size	L	L ₂	E	F _E	H ₃	d _{be}	G _{Wub}
		mm	mm	mm	mm	mm	mm	kg
WS0105	50	75	23,5	1,5	+ 1,0	12	19	0,8
WS0107	70	100	31,5	2,5	+ 1,5	18	26	1,8
WS0108	85	110	35	2,5	+ 2,0	18	38	2,7
WS0110	100	125	37,5	3	+ 2,0	20	42	4,9
WS0112	125	145	44	3,5	+ 2,5	25	54	7,5
WS0114	145	160	47,5	4	+ 2,5	30	66	10,6
WS0117	170	190	60,5	5	+ 3,0	30	90	18,0
WS0120	200	245	79,5	6	+ 3,0	35	100	31,0
WS0123	230	270	88,5	7	+ 3,5	35	115	43,5
WS0126	260	285	88,5	7	+ 4,0	45	150	63,0
WS0130	300	330	107,5	7	+ 4,0	50	162	91,5
WS0136	360	417	140	8	+ 4,0	55	215	146,2
WS0140	400	400	137	7,5	+ 4,0	55	250	160,4

For further information see chapter „Introduction“ as well as chapter „Elastomer Jaw Couplings RINGFEDER® TNS Basic information“ in the Product Paper & Tech Paper „RINGFEDER® Elastomer Jaw Couplings“

To continue see next page

Elastomer Jaw Couplings RINGFEDER® TNS S-St

Explanation

T_{KN} = Nom. Transmissible torque	D₁ = Outer diameter	H₃ = Length of damping module
T_{Kmax} = Max. transmissible torque of the coupling	D₂ = Outer diameter hub	d_{be} = Inner diameter elastic intermediate ring
n_{max} = Max. rotation speed	C₁ = Guided length in hub bore	GW_{ub} = Weight, unbored
d_{1kmax} = Max. bore diameter d ₁ with keyway acc. to DIN 6885-1	L = Total length	
d_{2kmax} = Max. bore diameter d ₂ with keyway acc. to DIN 6885-1	L₂ = Length on the hub	
	E = Gap width between left and right component	
	F_E = Tolerance of the gap width E	

Ordering example

Identifier	Size	d _{1k}	d _{2k}	Further details
WS0117	170	85	85	*

^{*)}Without any other specification, we deliver as a standard: with set screws and keyway acc. to DIN 6885-1, keyway side fit P9, bore tolerance H7

Further information on
RINGFEDER® TNS S-St
 on www.ringfeder.com

Disclaimer of liability

All technical details and notes are non-binding and cannot be used as a basis for legal claims. The user is obligated to determine whether the represented products meet his requirements. We reserve the right carry out modifications at any time in the interests of technical progress.

Elastomer Jaw Couplings

RINGFEDER® TNS S-LSt

Coupling with extended hubs

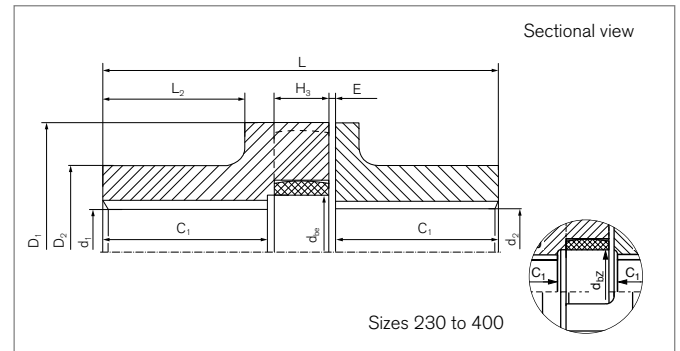
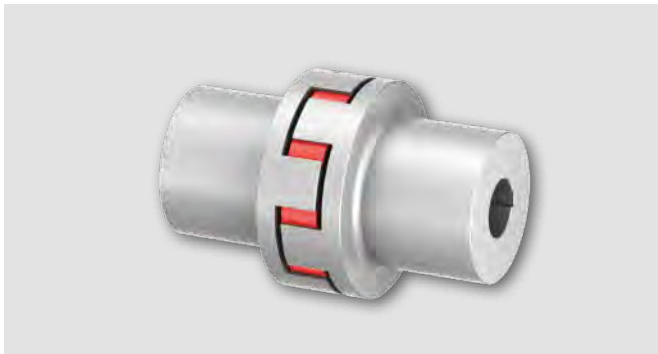

Identifier	Size	T_{KN}	T_{Kmax}	n_{max}	d_{1kmax}	d_{2kmax}	D_1	D_2	C_1
		Nm	Nm	1/min	mm	mm	mm	mm	mm
WS0105-L	50	15	40	15000	25	25	50	42	40,5
WS0108-L	85	75	225	9000	40	40	85	60	80,5
WS0110-L	100	130	390	7250	42	42	105	65	80,5
WS0112-L	125	250	750	6000	55	55	126	85	110,5
WS0114-L	145	400	1200	5250	65	65	145	95	110,5
WS0117-L	170	630	1900	4500	85	85	170	120	140,5
WS0120-L	200	1100	3300	3750	95	95	200	135	140
WS0123-L	230	1700	5150	3250	105	105	230	150	170
WS0126-L	260	2650	7950	3000	125	125	260	180	170
WS0140-L	400	8900	26700	1900	160	160	400	225	183,5

Identifier	Size	L	L_2	E	F_E	H_3	d_{be}	G_{Wub}
		mm	mm	mm	mm	mm	mm	kg
WS0105-L	50	96	34	1,5	+ 1,0	12	19	1,0
WS0108-L	85	184	72	2,5	+ 2,0	18	38	4,3
WS0110-L	100	187	68,5	3	+ 2,0	20	42	5,8
WS0112-L	125	253	98	3,5	+ 2,5	25	54	12,3
WS0114-L	145	259	97	4	+ 2,5	30	66	16,1
WS0117-L	170	321	126	5	+ 3,0	30	90	29,6
WS0120-L	200	328	124	6	+ 3,0	35	100	39,6
WS0123-L	230	390	151	7	+ 3,5	35	115	59,0
WS0126-L	260	400	146	7	+ 4,0	45	150	85,3
WS0140-L	400	440	157	7,5	+ 4,0	55	250	173,0

For further information see chapter „Introduction“ as well as chapter „Elastomer Jaw Couplings RINGFEDER® TNS Basic information“ in the Product Paper & Tech Paper „RINGFEDER® Elastomer Jaw Couplings“

To continue see next page

Elastomer Jaw Couplings RINGFEDER® TNS S-LSt

Explanation

T_{KN} = Nom. Transmissible torque	D₁ = Outer diameter	F_E = Tolerance of the gap width E
T_{Kmax} = Max. transmissible torque of the coupling	D₂ = Outer diameter hub	H₃ = Length of damping module
n_{max} = Max. rotation speed	C₁ = Guided length in hub bore	d_{be} = Inner diameter elastic intermediate ring
d_{1kmax} = Max. bore diameter d ₁ with keyway acc. to DIN 6885-1	L = Total length	Gw_{ub} = Weight, unbored
d_{2kmax} = Max. bore diameter d ₂ with keyway acc. to DIN 6885-1	L₂ = Length on the hub	
	E = Gap width between left and right component	

Ordering example

Identifier	Size	d _{1k}	d _{2k}	Further details
WS0117-L	170	85	85	*

^{*)}Without any other specification, we deliver as a standard: with set screws and keyway acc. to DIN 6885-1, keyway side fit P9, bore tolerance H7

Further information on
RINGFEDER® TNS S-LSt
 on www.ringfeder.com

Disclaimer of liability

All technical details and notes are non-binding and cannot be used as a basis for legal claims. The user is obligated to determine whether the represented products meet his requirements. We reserve the right carry out modifications at any time in the interests of technical progress.

Elastomer Jaw Couplings

RINGFEDER® TNS S-BT

Coupling with standard hub and brake drum

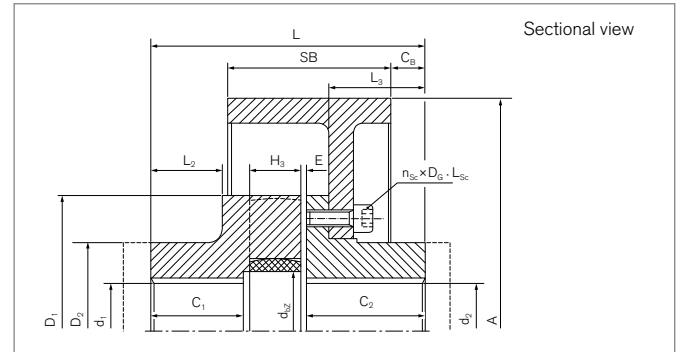
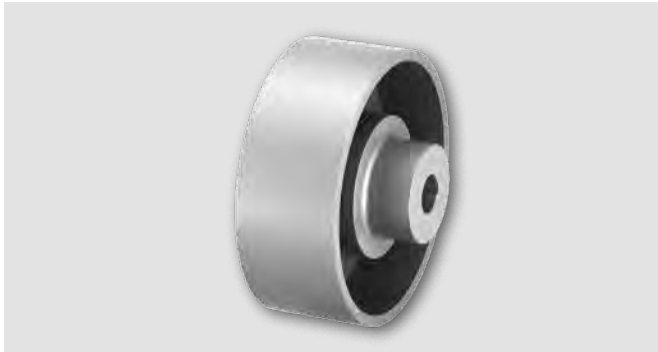

Identifier	Size	A	SB	T _{KN}	T _{Kmax}	T _{BR}	n _{max}	d _{1kmax}	d _{2kmax}	D ₁	D ₂	C ₁	C ₂	C _B
		mm	mm	Nm	Nm	Nm	1/min	mm	mm	mm	mm	mm	mm	mm
WS0510-200	100	200	75	130	390	260	4200	48	42	105	75	49,5	49,5	14
WS0512-200	125	200	75	250	750	310	4200	55	55	126	85	56,5	56,5	20
WS0514-200	145	200	75	400	1200	730	4200	65	65	145	95	61	61	21
WS0514-250	145	250	95	400	1200	730	3400	65	65	145	95	61	61	13
WS0517-250	170	250	95	630	1900	1200	3400	85	85	170	120	75	75	27
WS0517-315	170	315	118	630	1900	1350	2700	85	85	170	120	75	75	13
WS0520-315	200	315	118	1100	3300	2450	2700	95	95	200	135	99	99	38
WS0520-400	200	400	150	1100	3300	2650	2100	95	95	200	135	99	99	26
WS0523-400	230	400	150	1700	5150	3800	2100	105	105	230	150	110	110	36
WS0523-500	230	500	190	1700	5150	3800	1700	105	105	230	150	110	110	25
WS0526-500	260	500	190	2650	7950	9000	1700	125	125	260	180	112,5	112,5	25
WS0530-630	300	630	236	3900	11700	10500	1360	140	140	300	200	131,5	131,5	20
WS0530-710	300	710	265	3900	11700	11000	1200	140	140	300	200	131,5	131,5	0
WS0536-630	360	630	236	6500	19500	26000	1360	150	150	360	210	172	172	51
WS0536-710	360	710	265	6500	19500	26000	1200	150	150	360	210	172	172	34
WS0540-710	400	710	265	8900	26700	35000	1200	160	160	400	225	163,5	163,5	30

For further information see chapter „Introduction“ as well as chapter „Elastomer Jaw Couplings RINGFEDER® TNS Basic information“ in the Product Paper & Tech Paper „RINGFEDER® Elastomer Jaw Couplings“

To continue see next page

Elastomer Jaw Couplings RINGFEDER® TNS S-BT

Identifier	Size	C _B	L	L ₂	L ₃	E	F _E	H ₃	d _{be}	Screws ISO 4762 - 8.8				Gw _{ub}
										n _{Sc}	D _G	L _{Sc}	T _A ¹⁾	
		mm	mm	mm	mm	mm	mm	mm	mm		mm	mm	Nm	kg
WS0510-200	100	14	125	37,5	39,5	3	+ 2,0	20	42	6	8	20	25	9,4
WS0512-200	125	20	145	44	45,5	3,5	+ 2,5	25	54	6	8	20	25	12,0
WS0514-200	145	21	160	47,5	48,5	4	+ 2,5	30	66	6	10	25	49	15,2
WS0514-250	145	13	160	47,5	48,5	4	+ 2,5	30	66	6	10	25	49	19,8
WS0517-250	170	27	190	60,5	62	5	+ 3,0	30	90	8	10	25	49	26,7
WS0517-315	170	13	190	60,5	62	5	+ 3,0	30	90	8	10	30	49	36,1
WS0520-315	200	38	245	79,5	84	6	+ 3,0	35	100	8	12	30	85	48,0
WS0520-400	200	26	245	79,5	84	6	+ 3,0	35	100	8	12	35	85	64,6
WS0523-400	230	36	270	88,5	93	7	+ 3,5	35	115	10	12	35	85	75,8
WS0523-500	230	25	270	88,5	93	7	+ 3,5	35	115	10	12	35	85	103,1
WS0526-500	260	25	285	88,5	91	7	+ 4,0	45	150	10	16	40	210	121,6
WS0530-630	300	20	330	107,5	110,5	7	+ 4,0	50	162	10	16	45	210	199,4
WS0530-710	300	0	330	107,5	110,5	7	+ 4,0	50	162	10	16	50	210	255,9
WS0536-630	360	51	417	140	144	8	+ 4,0	55	215	12	20	50	425	261,0
WS0536-710	360	34	417	140	144	8	+ 4,0	55	215	12	20	55	425	304,5
WS0540-710	400	30	400	137	141	7,5	+ 4,0	55	250	14	20	50	425	317,6

Explanation

A	= Max. outer diameter	D₂	= Outer diameter hub	n_{Sc}	= Quantity of screws
SB	= Disc width	C₁	= Guided length in hub bore	D_G	= Thread
T_{KN}	= Nom. Transmissible torque	C₁	= Guided length in hub bore	L_{Sc}	= Screw length
T_{Kmax}	= Max. transmissible torque of the coupling	C_B	= Brake disc distance	F_{Sc}	= Screw strength class
T_{BR}	= Brake torque	L	= Total length	T_A	= Max tightened torque of the clamping screws
n_{max}	= Max. rotation speed	L₂	= Length on the hub	Gw_{ub}	= Weight, unbored
d_{1kmax}	= Max. bore diameter d ₁ with keyway acc. to DIN 6885-1	L₃	= Length		
d_{2kmax}	= Max. bore diameter d ₂ with keyway acc. to DIN 6885-1	E	= Gap width between left and right component		
D₁	= Outer diameter	F_E	= Tolerance of the gap width E		
		H₃	= Length of damping module		
		d_{be}	= Inner diameter elastic intermediate ring		

Ordering example

Identifier	Size	d _{1k}	d _{2k}	Further details
WS0523-400	230	105	105	*

¹⁾Without any other specification, we deliver as a standard: with set screws and keyway acc. to DIN 6885-1, keyway side fit P9, bore tolerance H7

Further information on
RINGFEDER® TNS S-BT
 on www.ringfeder.com

Disclaimer of liability

All technical details and notes are non-binding and cannot be used as a basis for legal claims. The user is obligated to determine whether the represented products meet his requirements. We reserve the right carry out modifications at any time in the interests of technical progress.

Elastomer Jaw Couplings

RINGFEDER® TNS SDD-5

Coupling with detachable claw rings

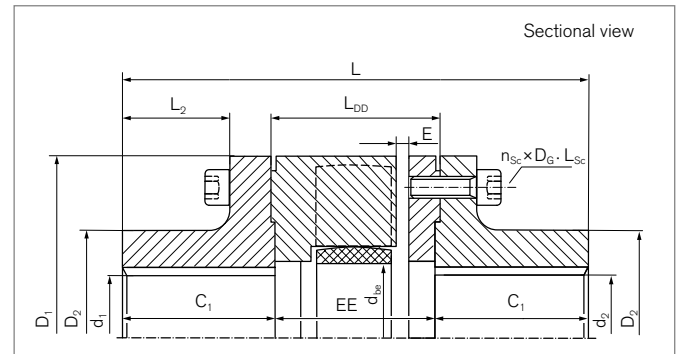
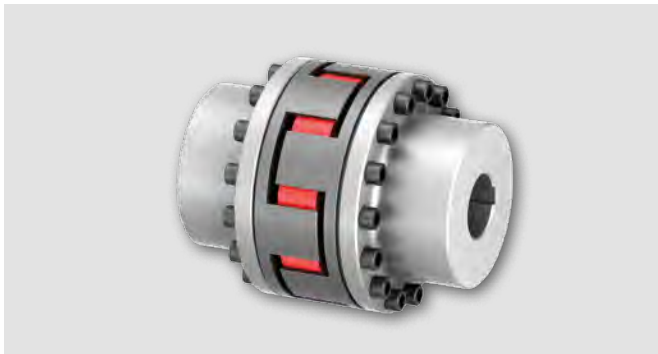

Identifier	Size	T_{KN}	T_{Kmax}	n_{max}	d_{1kmax}	d_{2kmax}	D_1	D_2	C_1	L	L_2
		Nm	Nm	1/min	mm	mm	mm	mm	mm	mm	mm
WS0710	100	130	390	7250	45	45	105	65	49	150	37,5
WS0712	125	250	750	6000	55	55	126	80	56	170	42,5
WS0714	145	400	1200	5250	65	65	145	92	60,5	189	44
WS0717	170	630	1900	4500	75	75	170	110	74,5	217	58
WS0720	200	1100	3300	3750	95	95	200	135	98,5	274	82
WS0723	230	1700	5150	3250	110	110	230	160	110	301	90
WS0726	260	2650	7950	3000	125	125	260	180	112,5	321	88
WS0730	300	3900	11700	2500	140	140	300	200	131,5	376	105
WS0736	360	6500	19500	2150	160	160	360	225	172	469	142,5
WS0740	400	8900	26700	1900	160	160	400	225	172	469	142,5

Identifier	Size	L_{DD}	E	F_E	EE	d_{be}	Screws ISO 4762 - 8.8				
							n_{Sc}	D_G	L_{Sc}	T_A	G_{Wub}
		mm	mm	mm	mm	mm		mm	mm	Nm	kg
WS0710	100	55	5	+ 2,0	52	42	9	8	20	25	5,3
WS0712	125	61	5	+ 2,5	58	54	9	10	25	49	8,8
WS0714	145	71	5	+ 2,5	68	66	9	12	30	85	13,3
WS0717	170	71	5	+ 3,0	68	90	12	12	30	85	19,9
WS0720	200	81	6	+ 3,0	77	100	12	14	30	135	35,3
WS0723	230	86	7	+ 3,5	81	115	15	14	35	135	52,5
WS0726	260	101	8	+ 4,0	96	150	15	16	40	210	71,5
WS0730	300	118	8	+ 4,0	113	162	15	20	50	425	109,0
WS0736	360	130	8	+ 4,0	125	215	12	24	55	730	179,8
WS0740	400	130	8	+ 4,0	125	250	14	24	55	730	197,7

For further information see chapter „Introduction“ as well as chapter „Elastomer Jaw Couplings RINGFEDER® TNS Basic information“ in the Product Paper & Tech Paper „RINGFEDER® Elastomer Jaw Couplings“

To continue see next page

Elastomer Jaw Couplings RINGFEDER® TNS SDD-5

Explanation

T_{KN} = Nom. Transmissible torque	D₂ = Outer diameter hub	d_{be} = Inner diameter elastic intermediate ring
T_{Kmax} = Max. transmissible torque of the coupling	C₁ = Guided length in hub bore	n_{Sc} = Quantity of screws
n_{max} = Max. rotation speed	L = Total length	D_G = Thread
d_{1kmax} = Max. bore diameter d ₁ with keyway acc. to DIN 6885-1	L₂ = Length on the hub	L_{Sc} = Screw length
d_{2kmax} = Max. bore diameter d ₂ with keyway acc. to DIN 6885-1	L_{DD} = Distance dimension	F_{Sc} = Screw strength class
D₁ = Outer diameter	E = Gap width between left and right component	T_A = Max tightened torque of the clamping screws
	F_E = Tolerance of the gap width E	GW_{ub} = Weight, unbored
	EE = Distance of the hubs	

Ordering example

Identifier	Size	d _{1k}	d _{2k}	Further details
WS0723	230	110	110	*

*Without any other specification, we deliver as a standard: with set screws and keyway acc. to DIN 6885-1, keyway side fit P9, bore tolerance H7

Further information on
RINGFEDER® TNS SDD-5
 on www.ringfeder.com

Disclaimer of liability

All technical details and notes are non-binding and cannot be used as a basis for legal claims. The user is obligated to determine whether the represented products meet his requirements. We reserve the right carry out modifications at any time in the interests of technical progress.

Elastomer Jaw Couplings

RINGFEDER® TNS SDDL-5

Coupling with detachable claw rings and long flange hubs

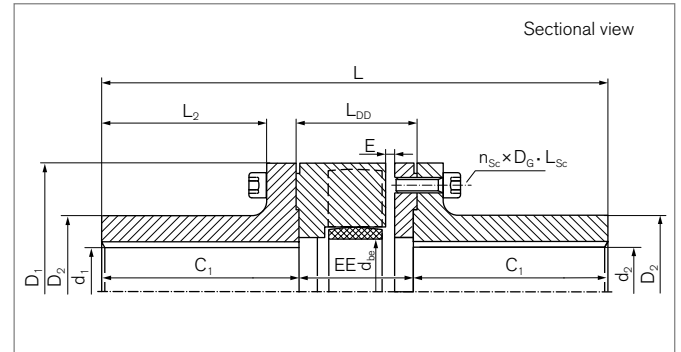
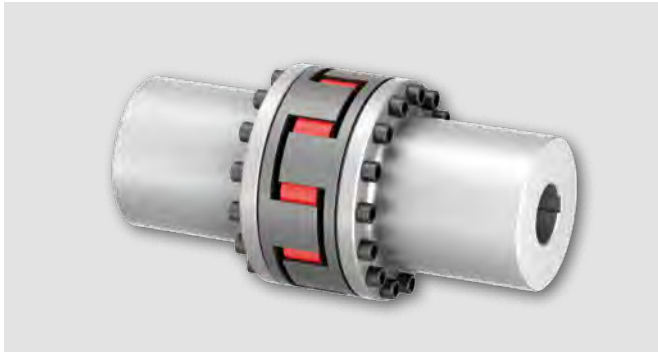

Identifier	Size	T _{KN}	T _{Kmax}	n _{max}	d _{1kmax}	d _{2kmax}	D ₁	D ₂	C ₁	L	L ₂
		Nm	Nm	1/min	mm	mm	mm	mm	mm	mm	mm
WS0710-L	100	130	390	7250	45	45	105	65	110	272	98,5
WS0712-L	125	250	750	6000	55	55	126	80	110	278	96,5
WS0714-L	145	400	1200	5250	65	65	145	92	110	288	93,5
WS0717-L	170	630	1900	4500	75	75	170	110	140	348	123,5
WS0720-L	200	1100	3300	3750	95	95	200	135	170	417	153,5
WS0723-L	230	1700	5150	3250	110	110	230	160	170	421	150
WS0726-L	260	2650	7950	3000	125	125	260	180	210	516	185,5
WS0730-L	300	3900	11700	2500	140	140	300	200	210	533	183,5
WS0736-L	360	6500	19500	2150	160	160	360	225	250	625	220,5
WS0740-L	400	8900	26700	1900	160	160	400	225	250	625	220,5

Identifier	Size	L _{DD}	E	F _E	EE	d _{be}	Screws ISO 4762 - 8.8				
							n _{Sc}	D _G	L _{Sc}	T _A	G _{wub}
		mm	mm	mm	mm	mm		mm	mm	Nm	kg
WS0710-L	100	55	5	+ 2,0	52	42	9	8	20	25	8,5
WS0712-L	125	61	5	+ 2,5	58	54	9	10	25	49	13,1
WS0714-L	145	71	5	+ 2,5	68	66	9	12	30	85	18,5
WS0717-L	170	71	5	+ 3,0	68	90	12	12	30	85	29,7
WS0720-L	200	81	6	+ 3,0	77	100	12	14	30	135	51,3
WS0723-L	230	86	7	+ 3,5	81	115	15	14	35	135	71,4
WS0726-L	260	101	8	+ 4,0	96	150	15	16	40	210	110,5
WS0730-L	300	118	8	+ 4,0	113	162	15	20	50	425	147,8
WS0736-L	360	130	8	+ 4,0	125	215	12	24	55	730	228,5
WS0740-L	400	130	8	+ 4,0	125	250	14	24	55	730	246,3

For further information see chapter „Introduction“ as well as chapter „Elastomer Jaw Couplings RINGFEDER® TNS Basic information“ in the Product Paper & Tech Paper „RINGFEDER® Elastomer Jaw Couplings“

To continue see next page

Elastomer Jaw Couplings RINGFEDER® TNS SDDL-5

Explanation

T_{KN} = Nom. Transmissible torque	D₂ = Outer diameter hub	d_{be} = Inner diameter elastic intermediate ring
T_{Kmax} = Max. transmissible torque of the coupling	C₁ = Guided length in hub bore	n_{Sc} = Quantity of screws
n_{max} = Max. rotation speed	L = Total length	D_G = Thread
d_{1kmax} = Max. bore diameter d ₁ with keyway acc. to DIN 6885-1	L₂ = Length on the hub	L_{Sc} = Screw length
d_{2kmax} = Max. bore diameter d ₂ with keyway acc. to DIN 6885-1	L_{DD} = Distance dimension	F_{Sc} = Screw strength class
D₁ = Outer diameter	E = Gap width between left and right component	T_A = Max tightened torque of the clamping screws
	F_E = Tolerance of the gap width E	GW_{ub} = Weight, unbored
	EE = Distance of the hubs	

Ordering example

Identifier	Size	d _{1k}	d _{2k}	Further details
WS0726-L	260	125	125	*

^{*)}Without any other specification, we deliver as a standard: with set screws and keyway acc. to DIN 6885-1, keyway side fit P9, bore tolerance H7

Further information on
RINGFEDER® TNS SDDL-5
 on www.ringfeder.com

Disclaimer of liability

All technical details and notes are non-binding and cannot be used as a basis for legal claims. The user is obligated to determine whether the represented products meet his requirements. We reserve the right carry out modifications at any time in the interests of technical progress.

Elastomer Jaw Couplings

RINGFEDER® TNS SDDL-5-BS

Coupling with detachable claw rings,
long hubs and brake disc

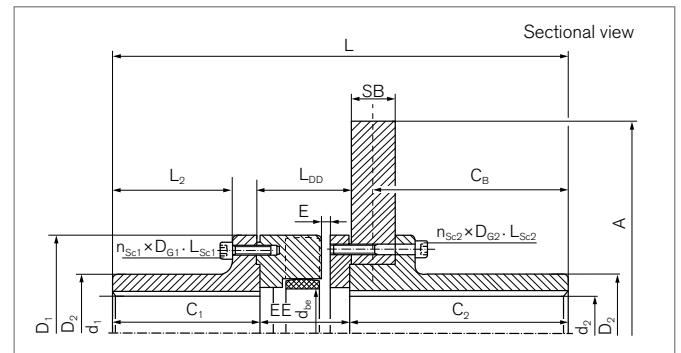

Identifier	Size	A	SB	$T_{KN} V_{k60D}$	$T_{Kmax} V_{k60D}$	n_{max}	d_{1kmax}	d_{2kmax}	D_1	D_2	C_1	C_2	C_B	L	L_2
		mm	mm	Nm	Nm	1/min	mm	mm	mm	mm	mm	mm	mm	mm	mm
WS5114-0355-30	145	355	30	600	1800	4800	65	65	145	92	110	166,5	150	344,5	93,5
WS5114-0400-30		400	30			4300	65	65							
WS5117-0400-30	170	400	30	950	2850	3750	75	75	170	110	140	166,5	150	374,5	123,5
WS5117-0450-30		450	30			3400	75	75							
WS5117-0500-30		500	30			3400	75	75							
WS5120-0450-30	200	450	30	1650	4950	3400	95	95	200	135	170	207	190	454	153,5
WS5120-0500-30		500	30			3000	95	95							
WS5120-0560-30		560	30			3000	95	95							
WS5123-0500-30	230	500	30	2580	7740	3250	110	110	230	160	170	207,5	190	458,5	150
WS5123-0560-30		560	30			3000	110	110							
WS5123-0630-30		630	30			2700	110	110							
WS5123-0710-30		710	30			2400	110	110							
WS5126-0630-30	260	630	30	3980	11940	2700	125	125	260	180	210	212,5	195	518,5	185,5
WS5126-0710-30		710	30			2400	125	125							
WS5130-0710-30	300	710	30	5850	17550	2400	140	140	300	200	210	212,5	195	535,5	183,5
WS5130-0800-30		800	30			2150	140	140							
WS5130-0800-40		800	40			2150	140	140							
WS5136-0800-30	360	800	30	9700	29100	2150	160	160	360	225	250	252,5	235	627,5	220,5
WS5136-0800-40		800	40			2150	160	160							
WS5136-1000-40		1000	40			1700	160	160							
WS5140-0800-30	400	800	30	13350	40050	1900	160	160	400	225	250	252,5	235	627,5	220,5
WS5140-0800-40		800	40			1900	160	160							
WS5140-1000-40		1000	40			1700	160	160							

For further information see chapter „Introduction“ as well as chapter „Elastomer Jaw Couplings RINGFEDER® TNS Basic information“ in the Product Paper & Tech Paper „RINGFEDER® Elastomer Jaw Couplings“

To continue see next page

Elastomer Jaw Couplings RINGFEDER® TNS SDDL-5-BS

Identifier	Size	L _{DD} mm	E mm	F _E mm	EE mm	d _{be} mm	Screws ISO 4762 - 8.8								G _{Wub} kg
							n _{Sc1}	D _{G1} mm	L _{Sc1} mm	T _{A1} Nm	n _{Sc2}	D _{G2} mm	L _{Sc2} mm	T _{A2} Nm	
WS5114-0355-30	145	71	5	+ 2,5	68	66	9	M12	30	85	9	M12	60	85	43,0
WS5114-0400-30					68						9	M12	60	85	49,3
WS5117-0400-30	170	71	5	+ 3,0	68	90	12	M12	30	85	12	M12	70	85	59,9
WS5117-0450-30					68						12	M12	70	85	67,7
WS5117-0500-30	200	81	6	+ 3,0	68	100	12	M14	30	135	12	M12	70	85	76,5
WS5120-0450-30					77						12	M14	60	135	59,9
WS5120-0500-30	200	81	6	+ 3,0	77	100	12	M14	30	135	12	M14	60	135	98,1
WS5120-0560-30					77						12	M14	60	135	109,9
WS5123-0500-30	230	86	7	+ 3,5	81	115	15	M14	35	135	15	M14	65	135	118,6
WS5123-0560-30					81						15	M14	65	135	130,3
WS5123-0630-30	230	86	7	+ 3,5	81	115	15	M14	35	135	15	M14	65	135	145,8
WS5123-0710-30					81						15	M14	65	135	165,6
WS5126-0630-30	260	101	8	+ 4,0	96	150	15	M16	40	210	15	M16	70	210	178,1
WS5126-0710-30					96						15	M16	70	210	198,0
WS5130-0710-30	300	118	8	+ 4,0	113	162	15	M20	50	425	15	M20	80	425	233,7
WS5130-0800-30					113						15	M20	80	425	258,8
WS5130-0800-40	300	118	8	+ 4,0	113	162	15	M20	50	425	15	M20	90	425	295,7
WS5136-0800-30					125						12	M24	85	730	337,7
WS5136-0800-40	360	130	8	+ 4,0	125	215	12	M24	55	730	12	M24	95	730	374,0
WS5136-1000-40					125						12	M24	95	730	462,7
WS5140-0800-30	400	130	8	+ 4,0	125	250	14	M24	55	730	14	M24	85	730	355,5
WS5140-0800-40					125						14	M24	95	730	391,8
WS5140-1000-40	400	130	8	+ 4,0	125	250	14	M24	55	730	14	M24	95	730	480,5
WS5140-1000-40					125						14	M24	95	730	480,5

To continue see next page

Elastomer Jaw Couplings RINGFEDER® TNS SDDL-5-BS

Explanation

A	= Max. outer diameter	D₂	= Outer diameter hub	d_{be}	= Inner diameter elastic intermediate ring
SB	= Disc width	C₁	= Guided length in hub bore	n_{Sc1}	= Quantity of screws D _{G1}
T_{KN VK60D}	= Nom. coupling torque when using the flexible element VK60D	C₂	= Guided length in hub bore	D_{G1}	= Thread
T_{Kmax VK60D}	= Max. transmittable torque of the coupling when using the flexible element VK60D	C_B	= Brake disc distance	L_{Sc1}	= Length of screw D _{G1}
n_{max}	= Max. rotation speed	L	= Total length	T_{A1}	= Tightened torque of clamping screw D _{G1}
d_{1kmax}	= Max. bore diameter d ₁ with keyway acc. to DIN 6885-1	L₂	= Length on the hub	n_{Sc2}	= Quantity of screws D _{G2}
d_{2kmax}	= Max. bore diameter d ₂ with keyway acc. to DIN 6885-1	L_{DD}	= Distance dimension	D_{G2}	= Thread
D₁	= Outer diameter	E	= Gap width between left and right component	L_{Sc2}	= Length of screw D _{G2}
		F_E	= Tolerance of the gap width E	T_{A2}	= Tightened torque of clamping screw D _{G2}
		EE	= Distance of the hubs	F_{Sc}	= Screw strength class
				GW_{ub}	= Weight, unbored

Ordering example

Identifier	Size	d _{1k}	d _{2k}	Further details
WS5120-0450-30	200	95	95	*

^{*)} Without any other specification, we deliver as a standard: with set screws and keyway acc. to DIN 6885-1, keyway side fit P9, bore tolerance H7

Further information on
RINGFEDER® TNS SDDL-5-BS
 on www.ringfeder.com

Disclaimer of liability

All technical details and notes are non-binding and cannot be used as a basis for legal claims. The user is obligated to determine whether the represented products meet his requirements. We reserve the right carry out modifications at any time in the interests of technical progress.

Elastomer Jaw Couplings

RINGFEDER® TNS SX

Coupling with standard hub and claw flange

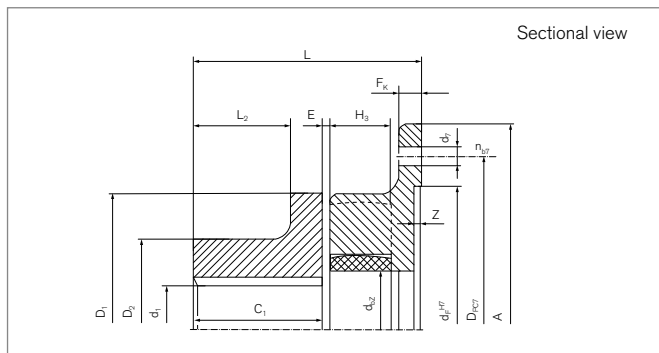

Identifier	Size	T _{KN}	T _{Kmax}	n _{max}	d _{1kmax}	A	D ₁	D ₂	C ₁	F _K	
		Nm	Nm	1/min	mm	mm	mm	mm	mm	mm	
WS1010	100	70	210	7250	48	145	105	75	49,5	10	
WS1012	125	128	385	6000	55	170	126	85	56,5	10	
WS1014	145	220	660	5250	65	194	145	95	61	12	
WS1017	170	340	1020	4500	85	220	170	120	75	14	
WS1020	200	590	1770	3750	95	250	200	135	99	14	
WS1023	230	900	2700	3250	105	290	230	150	110	14	
WS1026	260	1400	4200	3000	125	335	260	180	112,5	18	
WS1030	300	2090	6270	2500	140	385	300	200	131,5	24	
WS1036-0650	360	3450	10350	2150	150	455	360	210	172	28	
WS1036-0750		514				30					
WS1040	400	4750	14250	1900	160	514	400	225	163,5	30	
WS1040-0866		4750				595					30
WS1040-L		4750				514					30
WS1040-L-0866	400-L	4750	14250	1900	160	595	400	225	183,5	30	

For further information see chapter „Introduction“ as well as chapter „Elastomer Jaw Couplings RINGFEDER® TNS Basic information“ in the Product Paper & Tech Paper „RINGFEDER® Elastomer Jaw Couplings“

To continue see next page

Elastomer Jaw Couplings RINGFEDER® TNS SX

Identifier	Size	Z	d _F	D _{PC7}	n _{b7}	d ₇	L	L ₂	E	H ₃	d _{be}	G _{Wub}
		mm	mm	mm		mm	mm	mm	mm	mm	mm	kg
WS1010	100	2	100	128	6	9	84,5	37,5	3	20	42	2,9
WS1012	125	2	130	148	6	9	97	44	3,5	25	54	4,5
WS1014	145	4	150	172	6	9	109	47,5	4	30	66	6,4
WS1017	170	4	170	195	6	13,5	126,5	60,5	5	30	90	10,4
WS1020	200	4	195	228	8	13,5	156,5	79,5	6	35	100	17,5
WS1023	230	4	220	265	8	13,5	171	88,5	7	35	115	24,4
WS1026	260	4	265	310	12	13,5	188	88,5	7	45	150	35,9
WS1030	300	4	315	360	16	13,5	218,5	107,5	7	50	162	53,2
WS1036-0650	360	5	360	420	16	17,5	271,5	140	8	55	215	84,4
WS1036-0750		5	420	480	20	17,5	273,5					84,4
WS1040	400	5	420	480	20	17,5	265	137	7,5	55	250	94,6
WS1040-0866		6	485	555	12	22	265					99,2
WS1040-L	400-L	5	420	480	20	17,5	285	157	7,5	55	250	100,9
WS1040-L-0866		6	485	555	12	22	285					105,5

Explanation

T_{KN} = Nom. Transmissible torque	D₂ = Outer diameter hub	L = Total length
T_{Kmax} = Max. transmissible torque of the coupling	C₁ = Guided length in hub bore	L₂ = Length on the hub
n_{max} = Max. rotation speed	F_K = Flange thickness	E = Gap width between left and right component
d_{1kmax} = Max. bore diameter d ₁ with keyway acc. to DIN 6885-1	Z = Depth of center value	H₃ = Length of damping module
A = Max. outer diameter	d_F = Center diameter	d_{be} = Inner diameter elastic intermediate ring
D₁ = Outer diameter	D_{PC7} = Pitch circle diameter of bore holes d ₇	G_{Wub} = Weight, unbored
	n_{b7} = Quantity of bore d ₇	
	d₇ = Bore diameter	

Ordering example

Identifier	Size	d _{1k}	Further details
WS1036-0750	360	150	*

^{*)} Without any other specification, we deliver as a standard: with set screws and keyway acc. to DIN 6885-1, keyway side fit P9, bore tolerance H7

Further information on
RINGFEDER® TNS SX
 on www.ringfeder.com

Disclaimer of liability

All technical details and notes are non-binding and cannot be used as a basis for legal claims. The user is obligated to determine whether the represented products meet his requirements. We reserve the right carry out modifications at any time in the interests of technical progress.

Elastomer Jaw Couplings

RINGFEDER® TNS SV

Coupling with inner hub and claw flange

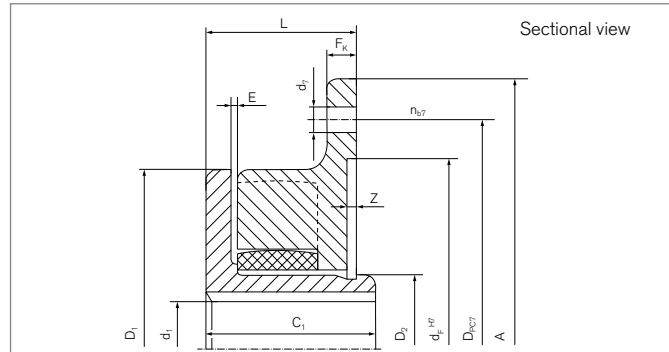
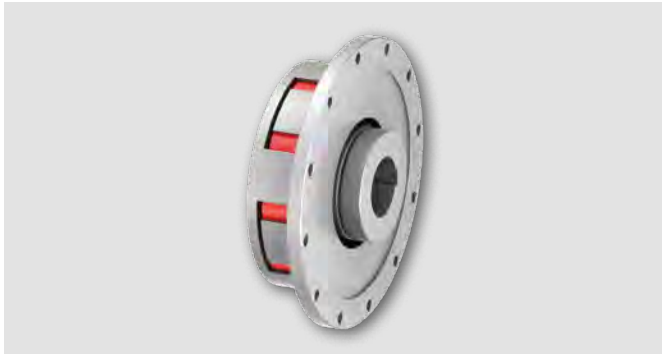

Identifier	Size	T _{KN}	T _{Kmax}	n _{max}	d _{1kmax}	A	D ₁	D ₂	C ₁	F _K
		Nm	Nm	1/min	mm	mm	mm	mm	mm	mm
WS1410	100	70	210	7250	27	145	105	38	50	10
WS1412	125	128	385	6000	34	170	126	48	57	10
WS1414	145	220	660	5250	42	194	145	60	65	12
WS1417	170	340	1020	4500	58	220	170	82	75	14
WS1420	200	590	1770	3750	65	250	200	95	85	14
WS1423	230	900	2700	3250	70	290	230	102	90	14
WS1426	260	1400	4200	3000	90	335	260	130	110	18
WS1430	300	2090	6270	2500	105	385	300	147	130	24
WS1436-0650	360	3450	10350	2150	140	455	360	210	175	28
WS1436-0750		514				30				
WS1440	400	4750	14250	1900	160	514	400	230	180	30
WS1440-0866		595				30				

For further information see chapter „Introduction“ as well as chapter „Elastomer Jaw Couplings RINGFEDER® TNS Basic information“ in the Product Paper & Tech Paper „RINGFEDER® Elastomer Jaw Couplings“

To continue see next page

Elastomer Jaw Couplings RINGFEDER® TNS SV

Identifier	Size	Z	d _F	D _{PC7}	n _{b7}	d ₇	L	E	d _{be}	G _{W_{ub}}
		mm	mm	mm		mm	mm	mm	mm	kg
WS1410	100	2	100	128	6	9	42	2	42	1,7
WS1412	125	2	130	148	6	9	47	2	54	2,8
WS1414	145	4	150	172	6	9	55	2	66	4,3
WS1417	170	4	170	195	6	13,5	60	2,5	90	6,8
WS1420	200	4	195	228	8	13,5	65	2,5	100	10,4
WS1423	230	4	220	265	8	13,5	70	4,5	115	13,4
WS1426	260	4	265	310	12	13,5	85,5	4,5	150	22,8
WS1430	300	4	315	360	16	13,5	100	4,5	162	36,2
WS1436-0650	360	5	360	420	16	17,5	123	7,5	215	71,4
WS1436-0750		5	420	480	20	17,5	125		215	75,4
WS1440	400	5	420	480	20	17,5	125	7,5	250	94,9
WS1440-0866		6	485	555	12	22	125		250	99,5

Explanation

T_{KN} = Nom. Transmissible torque	D₂ = Outer diameter hub	d₇ = Bore diameter
T_{Kmax} = Max. transmissible torque of the coupling	C₁ = Guided length in hub bore	L = Total length
n_{max} = Max. rotation speed	F_K = Guided length in hub bore	E = Gap width between left and right component
d_{1kmax} = Max. bore diameter d ₁ with keyway acc. to DIN 6885-1	Z = Depth of center value	d_{be} = Inner diameter elastic intermediate ring
A = Max. outer diameter	d_F = Center diameter	G_{W_{ub}} = Weight, unbored
D₁ = Outer diameter	D_{PC7} = Pitch circle diameter of bore holes d ₇	
	n_{b7} = Quantity of bore d ₇	

Ordering example

Identifier	Size	d _{1k}	Further details
WS1436-0750	360	140	*

^{*)} Without any other specification, we deliver as a standard: with set screws and keyway acc. to DIN 6885-1, keyway side fit P9, bore tolerance H7

Further information on
RINGFEDER® TNS SV
 on www.ringfeder.com

Disclaimer of liability

All technical details and notes are non-binding and cannot be used as a basis for legal claims. The user is obligated to determine whether the represented products meet his requirements. We reserve the right carry out modifications at any time in the interests of technical progress.

Elastomer Jaw Couplings

RINGFEDER® TNB BH

Combination of one-part design coupling hubs with Vkw buffer for highest torque transmission

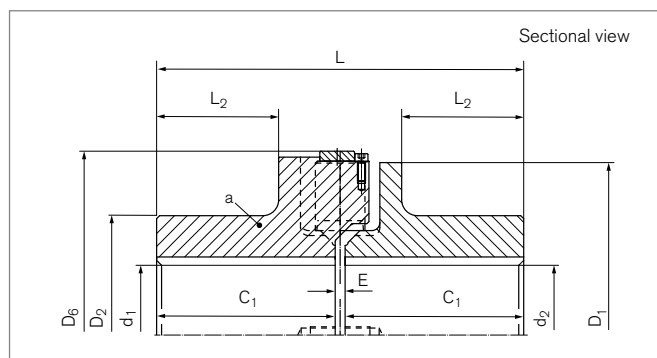
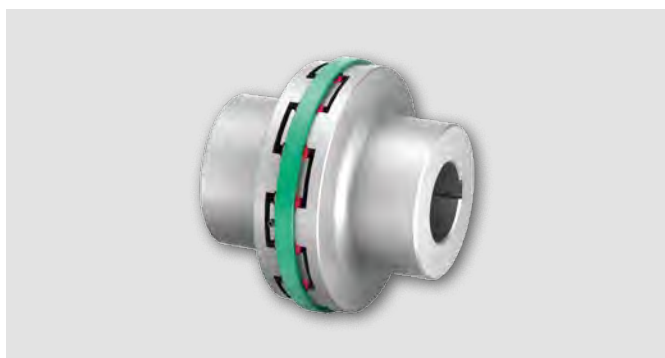

Identifier	Size	$T_{KN}^{2)}$	n_{max}	d_{1kmax}	d_{2kmax}	D_1	D_2	D_6
		Nm	1/min	mm	mm	mm	mm	mm
WB0130	300	8600	3300	135	135	300	210	320
WB0135	350	15000	2800	160	160	350	240	370
WB0140	400	23000	2450	180	180	400	270	420
WB0145	450	31000	2200	200	200	450	300	470
WB0150	500	41200	2000	220	220	500	330	530
WB0155	550	66000	1800	240	240	550	350	580
WB0160	600	80000	1650	250	250	600	375	630
WB0165	650	94000	1500	260	260	650	400	680
WB0170	700	130000	1400	300	300	700	450	740
WB0180	800	180000	1200	330	330	800	490	840
WB0190	900	260000	1100	360	360	900	540	940

Identifier	Size	C_1	L	L_2	E	$G_{wa}^{1)}$	G_{Wub}
		mm	mm	mm	mm	kg	kg
WB0130	300	160	330	103	10	51	101
WB0135	350	180	370	123	10	74	145
WB0140	400	198	406	134	10	107	210
WB0145	450	218	446	154	10	141	275
WB0150	500	236,5	487	163,5	14	188	371
WB0155	550	256,5	527	183,5	14	234	456
WB0160	600	258	530	180	14	286	565
WB0165	650	286,5	587	202,5	14	359	705
WB0170	700	327	668	234	14	496	985
WB0180	800	357	728	264	14	653	1285
WB0190	900	407	828	307	14	908	1790

1) Mass information for unbored coupling parts

2) Attention on peak load. See chapter „Elastomer Jaw Couplings RINGFEDER® TNB Basic information“ in Product Paper & Tech Paper „RINGFEDER® Elastomer Jaw Couplings“

To continue see next page

Elastomer Jaw Couplings RINGFEDER® TNB BH

Explanation

T_{KN} = Nom. Transmissible torque	D₁ = Outer diameter	E = Gap width between left and right component
n_{max} = Max. rotation speed	D₂ = Outer diameter hub	G_{wa} = Weight of subassembly a
d_{1kmax} = Max. bore diameter d ₁ with keyway acc. to DIN 6885-1	D₆ = Diameter	G_{wub} = Weight, unbored
d_{2kmax} = Max. bore diameter d ₂ with keyway acc. to DIN 6885-1	C₁ = Guided length in hub bore	
	L = Total length	
	L₂ = Length on the hub	

Ordering example

Identifier	Size	d _{1k}	d _{2k}	Buffer identifier (optional) ³⁾	Further details
WB0155	550	200	180	Pb82	*

³⁾ If a different buffer shore hardness is selected, the values from the corresponding table must be taken into account. See chapter „Elastomer Jaw Couplings RINGFEDER® TNB Basic information“ in Product Paper & Tech Paper „RINGFEDER® Elastomer Jaw Couplings“

⁴⁾ Without any other specification, we deliver as a standard: with set screws and keyway acc. to DIN 6885-1, keyway side fit P9, bore tolerance H7

Further information on
RINGFEDER® TNB BH
 on www.ringfeder.com

Disclaimer of liability

All technical details and notes are non-binding and cannot be used as a basis for legal claims. The user is obligated to determine whether the represented products meet his requirements. We reserve the right carry out modifications at any time in the interests of technical progress.

Elastomer Jaw Couplings

RINGFEDER® TNB BHD

Combination of an one-part design and a multi-part design
coupling hub and Vkr buffer

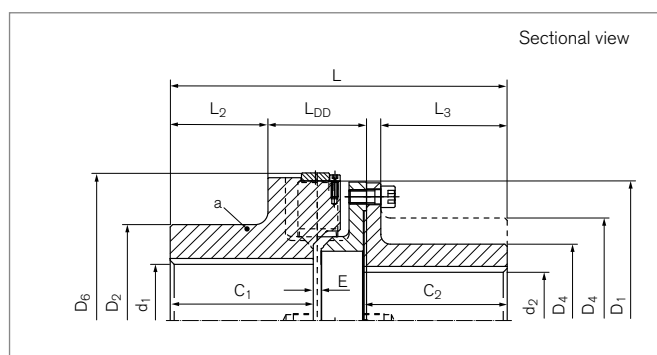

Identifier	Size	T_{KN^2}	n_{max}	d_{1kmax}	d_{2kmax}	D_1	D_2	D_4	D_6
		Nm	1/min	mm	mm	mm	mm	mm	mm
WB0230-A	300	6000	3300	135	110	300	210	170	320
WB0230-B	300	6000	3300	135	135	300	210	200	320
WB0235-A	350	10500	2800	160	120	350	240	180	370
WB0235-B	350	10500	2800	160	170	350	240	250	370
WB0240-A	400	16000	2450	180	140	400	270	210	420
WB0240-B	400	16000	2450	180	190	400	270	280	420
WB0245-A	450	21000	2200	200	170	450	300	250	470
WB0245-B	450	21000	2200	200	205	450	300	300	470
WB0250-A	500	28500	2000	220	180	500	330	270	530
WB0250-B	500	28500	2000	220	225	500	330	330	530
WB0255-A	550	45000	1800	240	200	550	350	280	580
WB0255-B	550	45000	1800	240	240	550	350	350	580
WB0260-A	600	55000	1650	250	235	600	375	330	630
WB0260-B	600	55000	1650	250	265	600	375	385	630
WB0265-A	650	65000	1500	260	250	650	400	350	680
WB0265-B	650	65000	1500	260	265	650	400	385	680
WB0270-A	700	90000	1400	300	260	700	450	370	740
WB0270-B	700	90000	1400	300	310	700	450	450	740
WB0280-A	800	120000	1200	330	320	800	490	450	840
WB0280-B	800	120000	1200	330	340	800	490	490	840
WB0290-A	900	180000	1100	360	340	900	540	480	940
WB0290-B	900	180000	1100	360	400	900	540	590	940

To continue see next page

Elastomer Jaw Couplings RINGFEDER® TNB BHD

Identifier	Size	C ₁	C ₂	L	L ₂	L ₃	L _{DD}	E	G _{wa} ¹⁾	G _{Wub}
		mm	mm	mm	mm	mm	mm	mm	kg	kg
WB0230-A	300	160	160	384	103	139	124	10	51	104
WB0230-B	300	160	186	410	103	165	124	10	51	120
WB0235-A	350	180	180	424	123	159	124	10	74	142
WB0235-B	350	180	231	475	123	210	124	10	74	191
WB0240-A	400	198	190	459	134	167	138	10	107	206
WB0240-B	400	198	239	508	134	216	138	10	107	265
WB0245-A	450	218	200	489	154	177	138	10	141	271
WB0245-B	450	218	239	528	154	216	138	10	141	322
WB0250-A	500	236,5	228	547,5	163,5	199	160	14	188	373
WB0250-B	500	236,5	279	598,5	163,5	250	160	14	188	451
WB0255-A	550	256,5	228	567,5	183,5	199	160	14	234	442
WB0255-B	550	256,5	279	618,5	183,5	250	160	14	234	534
WB0260-A	600	258	258	604	180	229	170	14	286	578
WB0260-B	600	258	299	645	180	270	170	14	286	672
WB0265-A	650	286,5	258	637,5	202,5	225	182	14	357	695
WB0265-B	650	286,5	299	678,5	202,5	266	182	14	357	767
WB0270-A	700	327	298	727	234	263	200	14	494	941
WB0270-B	700	327	345	774	234	310	200	14	494	1105
WB0280-A	800	357	338	797	264	303	200	14	652	1316
WB0280-B	800	357	365	824	264	330	200	14	652	1426
WB0290-A	900	407	338	853	307	297	214	14	906	1695
WB0290-B	900	407	399	914	307	358	214	14	906	2042

¹⁾ Mass information for unbored coupling parts

²⁾ Attention on peak load. See chapter „Elastomer Jaw Couplings RINGFEDER® TNB Basic information“ in Product Paper & Tech Paper „RINGFEDER® Elastomer Jaw Couplings“

To continue see next page

Elastomer Jaw Couplings RINGFEDER® TNB BHD

Explanation

T_{KN} = Nom. Transmissible torque	D₂ = Outer diameter	L₃ = Length
n_{max} = Max. rotation speed	D₄ = Outer diameter	L_{DD} = Distance dimension
d_{1kmax} = Max. bore diameter d ₁ with keyway acc. to DIN 6885-1	D₆ = Diameter	E = Gap width between left and right component
d_{2kmax} = Max. bore diameter d ₂ with keyway acc. to DIN 6885-1	C₁ = Guided length in hub bore	G_{wa} = Weight of subassembly a
D₁ = Outer diameter	C₂ = Guided length in hub bore	G_{wub} = Weight, unbored
	L = Total length	
	L₂ = Length on the hub	

Ordering example

Identifier	Size	d _{1k}	d _{2k}	Buffer identifier (optional) ³⁾	Further details
WB0240-B	400	180	170	Pb82	*

³⁾ If a different buffer shore hardness is selected, the values from the corresponding table must be taken into account. See chapter „Elastomer Jaw Couplings RINGFEDER® TNB Basic information“ in Product Paper & Tech Paper „RINGFEDER® Elastomer Jaw Couplings“

⁴⁾ Without any other specification, we deliver as a standard: with set screws and keyway acc. to DIN 6885-1, keyway side fit P9, bore tolerance H7

Further information on
RINGFEDER® TNB BHD
 on www.ringfeder.com

Disclaimer of liability

All technical details and notes are non-binding and cannot be used as a basis for legal claims. The user is obligated to determine whether the represented products meet his requirements. We reserve the right carry out modifications at any time in the interests of technical progress.

Elastomer Jaw Couplings

RINGFEDER® TNB BHD-BS

Combination of an one-part design and a multi-part design coupling hub with brake disc and Vkr buffer.

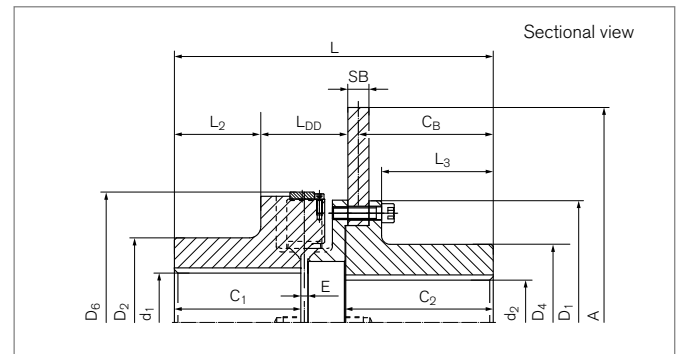
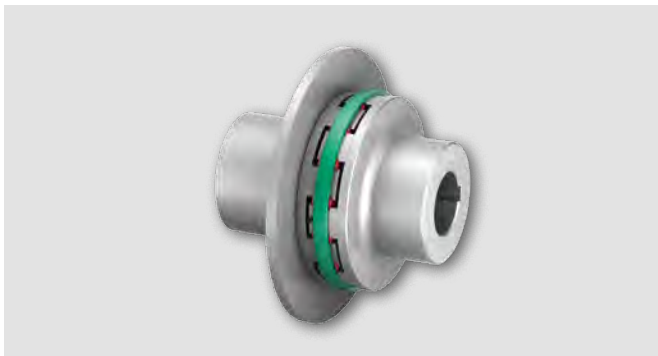

Identifier	Size	A	SB	T_{KN^2}	T_{BR}	n_{max}	d_{1kmax}	d_{2kmax}	D_1	D_2	D_4	D_6
		mm	mm	Nm	Nm	1/min	mm	mm	mm	mm	mm	mm
WB0730-0630	300	630	30	6000	18000	2700	135	135	300	210	200	320
WB0735-0710	350	710	30	10500	31500	2400	160	170	350	240	250	370
WB0740-0800	400	800	30	16000	48000	2150	180	190	400	270	280	420
WB0745-0800	450	800	30	21000	63000	2150	200	205	450	300	300	470
WB0750-0900	500	900	30	28500	85500	1900	220	225	500	330	330	530
WB0755-0900	550	900	30	45000	135000	1800	240	240	550	350	350	580
WB0760-1000	600	1000	30	55000	165000	1650	250	265	600	375	385	630
WB0765-1000	650	1000	30	65000	195000	1500	260	265	650	400	385	680
WB0770-1200	700	1200	30	90000	270000	1400	300	310	700	450	450	740
WB0780-1400	800	1400	30	120000	375000	1200	330	340	800	490	490	840
WB0790-1500	900	1500	30	180000	540000	1100	360	400	900	540	590	940

Identifier	Size	C_1	C_2	C_B	L	L_2	L_3	L_{DD}	E	$G_{WBS}^{1)}$	G_{Wub}
		mm	mm	mm	mm	mm	mm	mm	mm	kg	kg
WB0730-0630	300	160	216	198	440	103	165	124	10	142	193
WB0735-0710	350	180	261	243	505	123	210	124	10	210	284
WB0740-0800	400	198	269	251	538	134	216	138	10	276	383
WB0745-0800	450	218	269	251	558	154	216	138	10	299	440
WB0750-0900	500	236,5	309	290	628,5	163	250	160	14	413	601
WB0755-0900	550	256,5	309	290	648,5	183,5	250	160	14	450	684
WB0760-1000	600	258	329	310	675	180	270	170	14	571	857
WB0765-1000	650	286,5	329	309	708,5	202,5	266	182	14	594	951
WB0770-1200	700	327	375	355	804	234	310	200	14	876	1370
WB0780-1400	800	357	395	375	854	264	330	200	14	1136	1788
WB0790-1500	900	407	429	408	944	307	358	214	14	1552	2458

1) Mass information for unbored coupling parts

2) Attention on peak load. See chapter „Elastomer Jaw Couplings RINGFEDER® TNB Basic information“ in Product Paper & Tech Paper „RINGFEDER® Elastomer Jaw Couplings“

To continue see next page

Elastomer Jaw Couplings RINGFEDER® TNB BHD-BS

Explanation

A	= Max. outer diameter	D₁	= Outer diameter	L₂	= Length on the hub
SB	= Disc width	D₂	= Outer diameter hub	L₃	= Length
T_{KN}	= Nom. Transmissible torque	D₄	= Outer diameter hub	L_{DD}	= Distance dimension
T_{BR}	= Brake torque	D₆	= Diameter	E	= Gap width between left and right component
n_{max}	= Max. rotation speed	C₁	= Guided length in hub bore	GW_{BS}	= Weight of part with brake disc, unbored
d_{1kmax}	= Max. bore diameter d ₁ with keyway acc. to DIN 6885-1	C₂	= Guided length in hub bore	GW_{ub}	= Weight, unbored
d_{2kmax}	= Max. bore diameter d ₂ with keyway acc. to DIN 6885-1	C_B	= Brake disc distance		
		L	= Total length		

Ordering example

Identifier	Size	d _{1k}	d _{2k}	Buffer identifier (optional) ³⁾	Further details
WB0755-0900	550	240	200	Pb82	*

³⁾ If a different buffer shore hardness is selected, the values from the corresponding table must be taken into account. See chapter „Elastomer Jaw Couplings RINGFEDER® TNB Basic information“ in Product Paper & Tech Paper „RINGFEDER® Elastomer Jaw Couplings“

⁴⁾ Without any other specification, we deliver as a standard: with set screws and keyway acc. to DIN 6885-1, keyway side fit P9, bore tolerance H7

Further information on
RINGFEDER® TNB BHD-BS
 on www.ringfeder.com

Disclaimer of liability

All technical details and notes are non-binding and cannot be used as a basis for legal claims. The user is obligated to determine whether the represented products meet his requirements. We reserve the right carry out modifications at any time in the interests of technical progress.

Elastomer Jaw Couplings

RINGFEDER® TNB BHDD

Combination of multi-part design coupling hubs with radially removable central section and VkR buffer

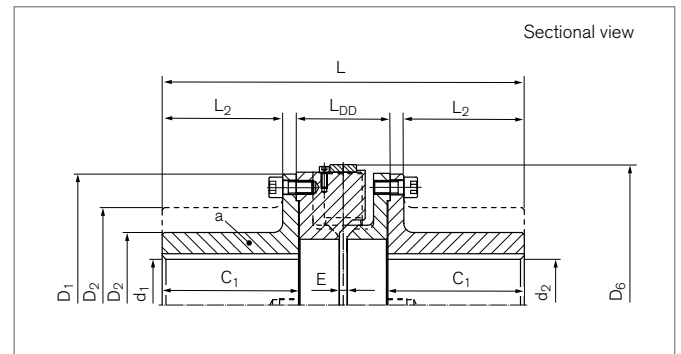
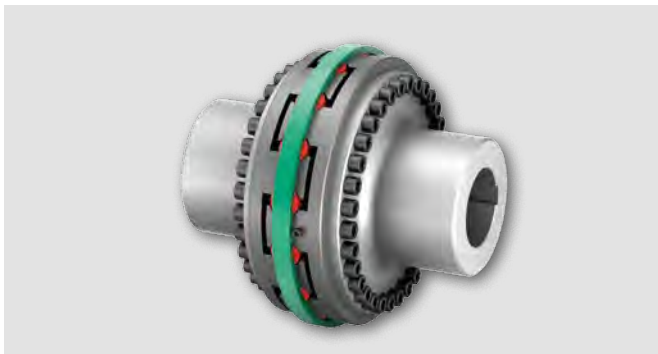

Identifier	Size	$T_{KN}^{(2)}$	n_{max}	d_{1kmax}	d_{2kmax}	D_1	D_2	D_6
		Nm	1/min	mm	mm	mm	mm	mm
WB0624-A	240	2500	4100	85	85	240	140	260
WB0624-B	240	2500	4100	100	100	240	150	260
WB0630-A	300	6000	3300	110	110	300	170	320
WB0630-B	300	6000	3300	135	135	300	200	320
WB0635-A	350	10500	2800	120	120	350	180	370
WB0635-B	350	10500	2800	170	170	350	250	370
WB0640-A	400	16000	2450	140	140	400	210	420
WB0640-B	400	16000	2450	190	190	400	280	420
WB0645-A	450	21000	2200	170	170	450	250	470
WB0645-B	450	21000	2200	205	205	450	300	470
WB0650-A	500	28500	2000	180	180	500	270	530
WB0650-B	500	28500	2000	225	225	500	330	530
WB0655-A	550	45000	1800	200	200	550	280	580
WB0655-B	550	45000	1800	240	240	550	350	580
WB0660-A	600	55000	1650	235	235	600	330	630
WB0660-B	600	55000	1650	265	265	600	385	630
WB0665-A	650	65000	1500	250	250	650	350	680
WB0665-B	650	65000	1500	265	265	650	385	680
WB0670-A	700	90000	1400	260	260	700	370	740
WB0670-B	700	90000	1400	310	310	700	450	740
WB0680-A	800	120000	1200	320	320	800	450	840
WB0680-B	800	120000	1200	340	340	800	490	840
WB0690-A	900	180000	1100	340	340	900	480	940
WB0690-B	900	180000	1100	400	400	900	590	940

To continue see next page

Elastomer Jaw Couplings RINGFEDER® TNB BHDD

Identifier	Size	C ₁	L	L ₂	L _{DD}	E	G _{wa} ¹⁾	G _{wub}
		mm	mm	mm	mm	mm	kg	kg
WB0624-A	240	130	360	113	104	10	30	58
WB0624-B	240	150	400	133	104	10	35	68
WB0630-A	300	160	438	139	124	10	56	109
WB0630-B	300	186	490	165	124	10	71	140
WB0635-A	350	180	478	159	124	10	72	139
WB0635-B	350	231	580	210	124	10	121	238
WB0640-A	400	190	512	167	138	10	104	203
WB0640-B	400	239	610	216	138	10	163	321
WB0645-A	450	200	532	177	138	10	136	266
WB0645-B	450	239	610	216	138	10	187	386
WB0650-A	500	228	608	199	160	14	195	380
WB0650-B	500	279	710	250	160	14	273	536
WB0655-A	550	228	608	199	160	14	219	427
WB0655-B	550	279	710	250	160	14	312	613
WB0660-A	600	258	678	229	170	14	303	595
WB0660-B	600	299	760	270	170	14	396	782
WB0665-A	650	258	688	225	182	14	350	688
WB0665-B	650	299	770	266	182	14	422	832
WB0670-A	700	298	786	263	200	14	467	914
WB0670-B	700	345	880	310	200	14	631	1241
WB0680-A	800	338	866	303	200	14	686	1350
WB0680-B	800	365	920	330	200	14	796	1570
WB0690-A	900	338	878	297	214	14	811	1601
WB0690-B	900	399	1000	358	214	14	1158	2295

¹⁾ Mass information for unbored coupling parts

²⁾ Attention on peak load. See chapter „Elastomer Jaw Couplings RINGFEDER® TNB Basic information“ in Product Paper & Tech Paper „RINGFEDER® Elastomer Jaw Couplings“

To continue see next page

Elastomer Jaw Couplings RINGFEDER® TNB BHDD

Explanation

T_{KN} = Nom. Transmissible torque	D₁ = Outer diameter	L_{DD} = Distance dimension
n_{max} = Max. rotation speed	D₂ = Outer diameter hub	E = Gap width between left and right component
d_{1kmax} = Max. bore diameter d ₁ with keyway acc. to DIN 6885-1	D₆ = Diameter	G_{wa} = Weight of subassembly a
d_{2kmax} = Max. bore diameter d ₂ with keyway acc. to DIN 6885-1	C₁ = Guided length in hub bore	G_{wub} = Weight, unbored
	L = Total length	
	L₂ = Length on the hub	

Ordering example

Identifier	Size	d _{1k}	d _{2k}	Buffer identifier (optional) ³⁾	Further details
WB0640-A	400	140	120	Pb82	*

³⁾ If a different buffer shore hardness is selected, the values from the corresponding table must be taken into account. See chapter „Elastomer Jaw Couplings RINGFEDER® TNB Basic information“ in Product Paper & Tech Paper „RINGFEDER® Elastomer Jaw Couplings“

¹⁾ Without any other specification, we deliver as a standard: with set screws and keyway acc. to DIN 6885-1, keyway side fit P9, bore tolerance H7

Further information on
RINGFEDER® TNB BHDD
 on www.ringfeder.com

Disclaimer of liability

All technical details and notes are non-binding and cannot be used as a basis for legal claims. The user is obligated to determine whether the represented products meet his requirements. We reserve the right carry out modifications at any time in the interests of technical progress.

Elastomer Jaw Couplings

RINGFEDER® TNB BHDDV

Combination of multi-part design coupling hubs for short shaft distances with VkR buffer

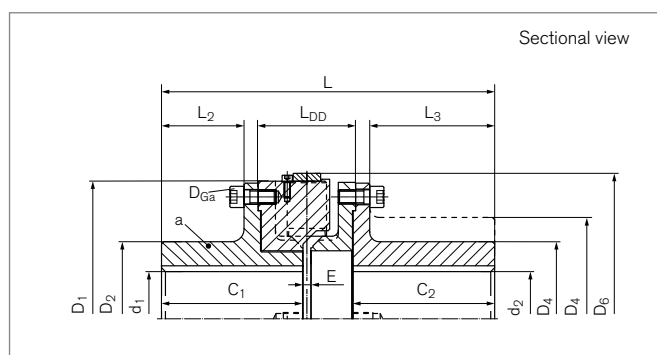
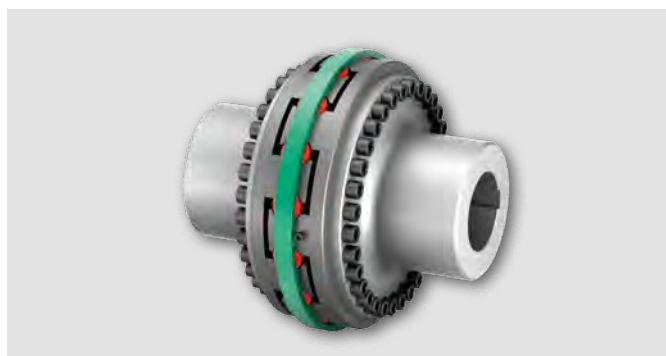

Identifier	Size	T_{KN^2}	n_{max}	d_{1kmax}	d_{2kmax}	D_1	D_2	D_4	D_6
		Nm	1/min	mm	mm	mm	mm	mm	mm
WB2024-A	240	2500	4100	85	85	240	140	140	260
WB2024-B	240	2500	4100	85	100	240	140	150	260
WB2030-A	300	6000	3300	110	110	300	170	170	320
WB2030-B	300	6000	3300	110	135	300	170	200	320
WB2035-A	350	10500	2800	120	120	350	180	180	370
WB2035-B	350	10500	2800	120	170	350	180	250	370
WB2040-A	400	16000	2450	140	140	400	210	210	420
WB2040-B	400	16000	2450	140	190	400	210	280	420
WB2045-A	450	21000	2200	170	170	450	250	250	470
WB2045-B	450	21000	2200	170	205	450	250	300	470
WB2050-A	500	28500	2000	180	180	500	270	270	530
WB2050-B	500	28500	2000	180	225	500	270	330	530
WB2055-A	550	45000	1800	200	200	550	280	280	580
WB2055-B	550	45000	1800	200	240	550	280	350	580
WB2060-A	600	55000	1650	235	235	600	330	330	630
WB2060-B	600	55000	1650	235	265	600	330	385	630
WB2065-A	650	65000	1500	250	250	650	350	350	680
WB2065-B	650	65000	1500	250	265	650	350	385	680
WB2070-A	700	90000	1400	260	260	700	370	370	740
WB2070-B	700	90000	1400	260	310	700	370	450	740
WB2080-A	800	120000	1200	320	320	800	450	450	840
WB2080-B	800	120000	1200	320	340	800	450	490	840
WB2090-A	900	180000	1100	340	340	900	480	480	940
WB2090-B	900	180000	1100	340	400	900	480	590	940

To continue see next page

Elastomer Jaw Couplings RINGFEDER® TNB BHDDV

Identifier	Size	C ₁	C ₂	L	L ₂	L ₃	L _{DD}	E	G _{wa} ¹⁾	G _{Wub}
		mm	mm	mm	mm	mm	mm	mm	kg	kg
WB2024-A	240	130	130	315	68	113	104	10	28	56
WB2024-B	240	130	150	335	68	133	104	10	28	61
WB2030-A	300	160	160	384	85	139	124	10	52	105
WB2030-B	300	160	186	410	85	165	124	10	52	121
WB2035-A	350	180	180	424	105	159	124	10	71	138
WB2035-B	350	180	231	475	105	210	124	10	71	187
WB2040-A	400	190	190	451	106	167	138	10	103	202
WB2040-B	400	190	239	500	106	216	138	10	103	161
WB2045-A	450	200	200	471	116	177	138	10	134	264
WB2045-B	450	200	239	510	116	216	138	10	134	315
WB2050-A	500	228	228	539	130	199	160	14	191	377
WB2050-B	500	228	279	590	130	250	160	14	191	454
WB2055-A	550	228	228	539	130	199	160	14	220	428
WB2055-B	550	228	279	590	130	250	160	14	220	521
WB2060-A	600	258	258	604	155	229	170	14	303	595
WB2060-B	600	258	299	645	155	270	170	14	303	688
WB2065-A	650	258	258	609	146	225	182	14	350	688
WB2065-B	650	258	299	650	146	266	182	14	350	760
WB2070-A	700	298	298	698	175	263	200	14	465	912
WB2070-B	700	298	345	745	175	310	200	14	465	1076
WB2080-A	800	338	338	778	215	303	200	14	686	1350
WB2080-B	800	338	365	805	215	330	200	14	686	1460
WB2090-A	900	338	338	784	203	297	214	14	812	1601
WB2090-B	900	338	399	845	203	358	214	14	812	1948

¹⁾ Mass information for unbored coupling parts

²⁾ Attention on peak load. See chapter „Elastomer Jaw Couplings RINGFEDER® TNB Basic information“ in Product Paper & Tech Paper „RINGFEDER® Elastomer Jaw Couplings“

To continue see next page

Elastomer Jaw Couplings RINGFEDER® TNB BHDDV

Explanation

n_{max} = Max. rotation speed	D₄ = Outer diameter hub	L_{DD} = Distance dimension
T_{KN} = Nom. Transmissible torque	D₆ = Diameter	E = Gap width between left and right component
d_{1kmax} = Max. bore diameter d ₁ with keyway acc. to DIN 6885-1	C₁ = Guided length in hub bore	G_{wa} = Weight of subassembly a
d_{2kmax} = Max. bore diameter d ₂ with keyway acc. to DIN 6885-1	C₂ = Guided length in hub bore	G_{wub} = Weight, unbored
D₁ = Outer diameter	L = Total length	
D₂ = Outer diameter hub	L₂ = Length on the hub	
	L₃ = Length	

Ordering example

Identifier	Size	d _{1k}	d _{2k}	Buffer identifier (optional) ³⁾	Further details
WB2035-B	350	120	150	Pb82	*

³⁾ If a different buffer shore hardness is selected, the values from the corresponding table must be taken into account. See chapter „Elastomer Jaw Couplings RINGFEDER® TNB Basic information“ in Product Paper & Tech Paper „RINGFEDER® Elastomer Jaw Couplings“

⁴⁾ Without any other specification, we deliver as a standard: with set screws and keyway acc. to DIN 6885-1, keyway side fit P9, bore tolerance H7

Further information on
RINGFEDER® TNB BHDDV
 on www.ringfeder.com

Disclaimer of liability

All technical details and notes are non-binding and cannot be used as a basis for legal claims. The user is obligated to determine whether the represented products meet his requirements. We reserve the right carry out modifications at any time in the interests of technical progress.

Elastomer Jaw Couplings

RINGFEDER® TNB BHDDVV

Symmetrical setup of multi-part design coupling hubs with very short shaft distances with Vkr buffers

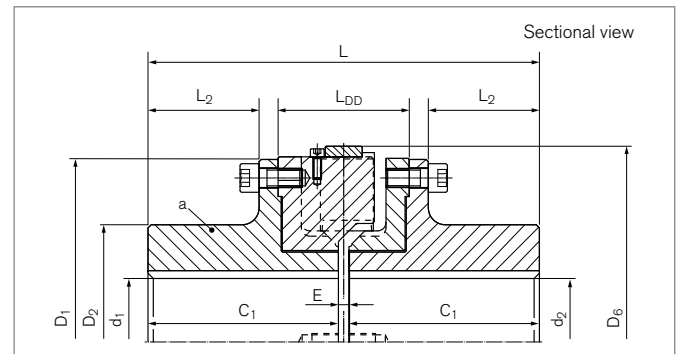
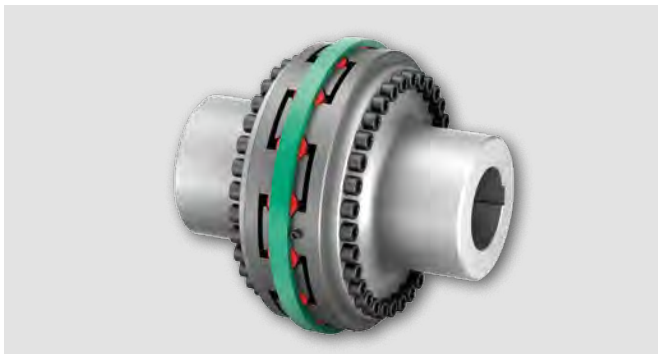

Identifier	Size	$T_{KN}^{2)}$	n_{max}	d_{1kmax}	d_{2kmax}	D_1	D_2	D_6
		Nm	1/min	mm	mm	mm	mm	mm
WB1624	240	2500	4100	85	85	240	140	260
WB1630	300	6000	3300	110	110	300	170	320
WB1635	350	10500	2800	120	120	350	180	370
WB1640	400	16000	2450	140	140	400	210	420
WB1645	450	21000	2200	170	170	450	250	470
WB1650	500	28500	2000	180	180	500	270	530
WB1655	550	45000	1800	200	200	550	280	580
WB1660	600	55000	1650	235	235	600	330	630
WB1665	650	65000	1500	250	250	650	350	680
WB1670	700	90000	1400	260	260	700	370	740
WB1680	800	120000	1200	320	320	800	450	840
WB1690	900	180000	1100	340	340	900	480	940

Identifier	Size	L	L_2	L_{DD}	E	Gwa ¹⁾	Gwub
		mm	mm	mm	mm	kg	kg
WB1624	240	270	68	104	10	28	54
WB1630	300	330	85	124	10	52	102
WB1635	350	370	105	124	10	71	137
WB1640	400	390	106	138	10	103	200
WB1645	450	410	116	138	10	134	263
WB1650	500	470	130	160	14	191	373
WB1655	550	470	130	160	14	220	429
WB1660	600	530	155	170	14	303	595
WB1665	650	530	146	182	14	350	688
WB1670	700	610	175	200	14	465	910
WB1680	800	690	215	200	14	686	1350
WB1690	900	690	203	214	14	812	1602

¹⁾ Mass information for unbored coupling parts

²⁾ Attention on peak load. See chapter „Elastomer Jaw Couplings RINGFEDER® TNB Basic information“ in Product Paper & Tech Paper „RINGFEDER® Elastomer Jaw Couplings“

To continue see next page

Elastomer Jaw Couplings RINGFEDER® TNB BHDDV

Explanation

T_{KN} = Nom. Transmissible torque	D₂ = Outer diameter hub	E = Gap width between left and right component
n_{max} = Max. rotation speed	D₆ = Diameter	G_{wa} = Weight of subassembly a
d_{1kmax} = Max. bore diameter d ₁ with keyway acc. to DIN 6885-1	C₁ = Guided length in hub bore	G_{wub} = Weight, unbored
d_{2kmax} = Max. bore diameter d ₂ with keyway acc. to DIN 6885-1	L = Total length	
D₁ = Outer diameter	L₂ = Length on the hub	
	L_{DD} = Distance dimension	

Ordering example

Identifier	Size	d _{1k}	d _{2k}	Buffer identifier (optional) ³⁾	Further details
WB1635	350	110	120	Pb82	*

³⁾ If a different buffer shore hardness is selected, the values from the corresponding table must be taken into account. See chapter „Elastomer Jaw Couplings RINGFEDER® TNB Basic information“ in Product Paper & Tech Paper „RINGFEDER® Elastomer Jaw Couplings“

⁴⁾ Without any other specification, we deliver as a standard: with set screws and keyway acc. to DIN 6885-1, keyway side fit P9, bore tolerance H7

Further information on
RINGFEDER® TNB BHDDV
 on www.ringfeder.com

Disclaimer of liability

All technical details and notes are non-binding and cannot be used as a basis for legal claims. The user is obligated to determine whether the represented products meet his requirements. We reserve the right carry out modifications at any time in the interests of technical progress.



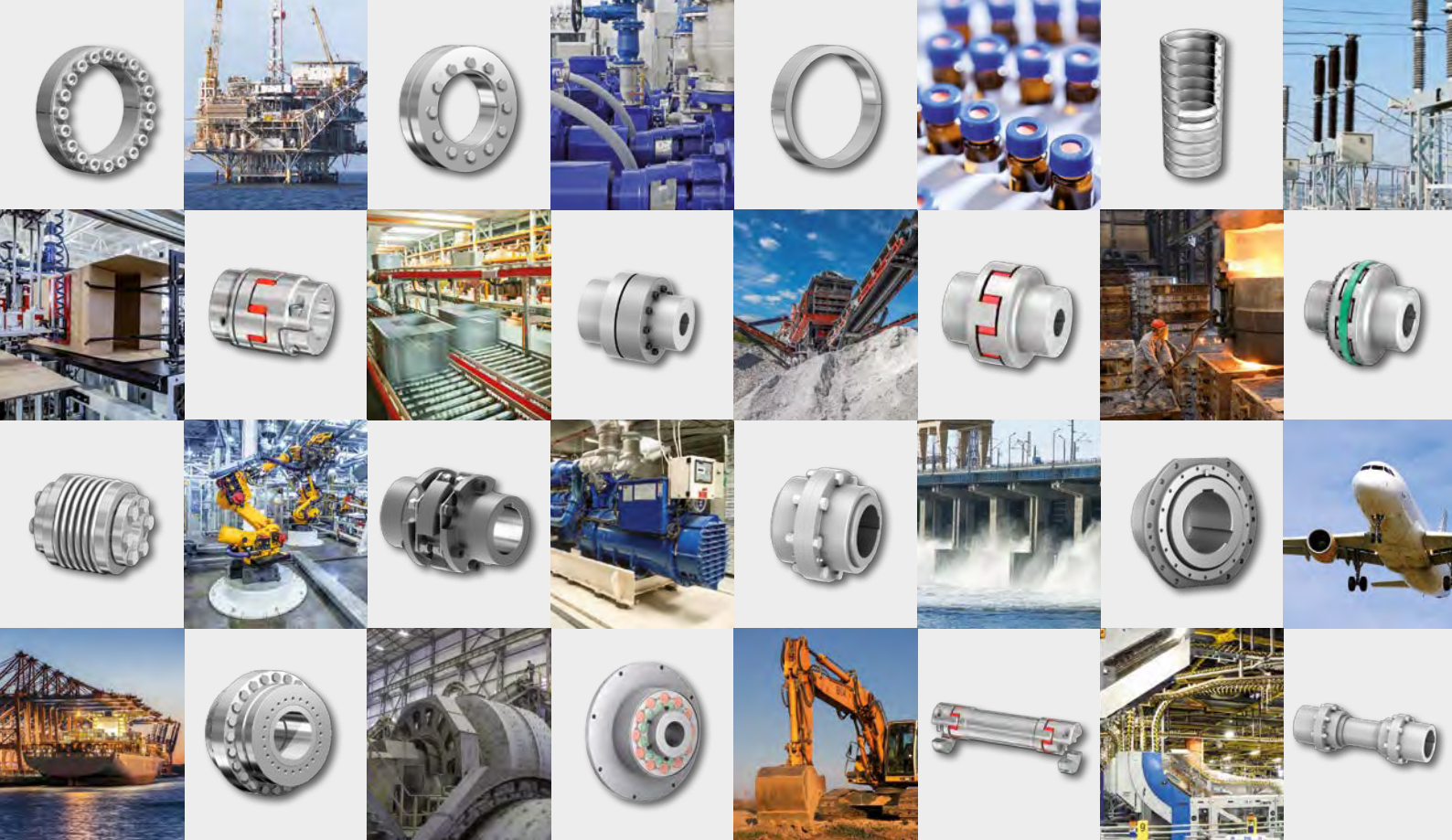

RINGFEDER POWER TRANSMISSION GMBH

Werner-Heisenberg-Straße 18, D-64823 Groß-Umstadt, Germany · Phone: +49 (0) 6078 9385-0 · Fax: +49 (0) 6078 9385-100
 E-mail: sales.international@ringfeder.com

RINGFEDER POWER TRANSMISSION TSCHAN GMBH

Zweibrücker Straße 104, D-66538 Neunkirchen, Germany · Phone: +49 (0) 6821 866-0 · Fax: +49 (0) 6821 866-4111
 E-mail: sales.tschan@ringfeder.com

RINGFEDER POWER TRANSMISSION USA CORPORATION

165 Carver Avenue, Westwood, NJ 07675, USA · Toll Free: +1 888 746-4333 · Phone: +1 201 666 3320 · Fax: +1 201 664 6053
 E-mail: sales.usa@ringfeder.com

HENFEL INDÚSTRIA METALÚRGICA LTDA.

Av. Major Hilário Tavares Pinheiro, 3447 · CEP 14871 300 · Jaboticabal - SP - Brazil · Phone: +55 (16) 3209-3422
 E-mail: vendas@henfel.com.br

RINGFEDER POWER TRANSMISSION INDIA PRIVATE LIMITED

Plot No. 4, Door No. 220, Mount - Poonamallee Road, Kattupakkam, Chennai – 600 056, India
 Phone: +91 (0) 44-2679 1411 · Fax: +91 (0) 44-2679 1422 · E-mail: sales.india@ringfeder.com

KUNSHAN RINGFEDER POWER TRANSMISSION COMPANY LIMITED

NO. 406 Jiande Road, Zhangpu 215321, Kunshan, Jiangsu Province, China
 Phone: +86 (0) 512-5745-3960 · Fax: +86 (0) 512-5745-3961 · E-mail: sales.china@ringfeder.com

Partner for Performance
www.ringfeder.com

