

myOutdoorKitchen Manual.

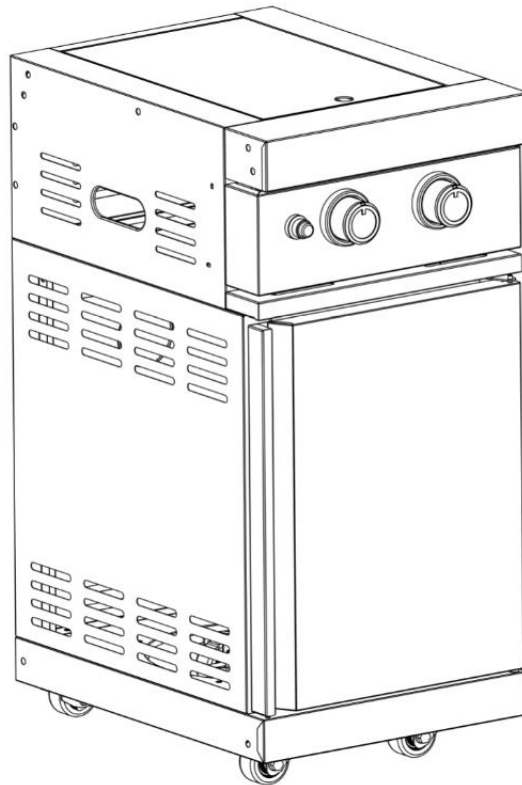

User Manual and Installation Instructions



OUTDOOR DOUBLE SIDE BURNER

Models: SUNC-DSB7641S / SUNC-DSB7909BLACK / SUNC-DSB7910S-GER / SUNC-DSB7911BLACK-GER / SUNC-BIDSB7920S / SUNC-BIDSB7921S-GER

- **USE OUTDOOR ONLY.**
- **READ THE INSTRUCTIONS BEFORE USING THE APPLIANCE.**
- **WARNING: ACCESSIBLE PARTS MAY BE VERY HOT. KEEP YOUNG CHILDEN AWAY.**
- **THIS APPLIANCE MUST BE KEPT AWAY FROM FLAMMABLE MATERIALS DURING USING.**
- **TURN OFF THE GAS SUPPLY AT THE GAS CYLINDER AFTER USING.**

PLEASE DO

- Use spanner to tighten all gas fittings.
- Check all gas hose and line connection for damage, cuts or cracks each time before using the appliance.
- Always leak test with soapy water.
- Check all burners regularly for insect nets such as spiders, ants, etc. Nets needs to be fully removed.
- Have the gas cylinder filled by an authorized gas supplier.
- Always wear protective gloves when handling hot components.
- Clean and maintain the appliance after each using.
- USE grill at least 1.0 m from any wall or surface, combustible material, gasoline, flame liquids or vapors.
- "Burning off" the barbecue after every use (for approx 15 minutes) will keep excessive food residue to a minimum.

PLEASE DO NOT

- Lean over appliance when lighting.
- Store combustible material, gasoline or flammable liquids or vapors within vicinity of appliance.
- Use appliance with any cover on.
- Use plastic or glass utensils on the appliance.
- Use the appliance in strong winds.
- Dismantle control valves.
- Test for gas leaks with a naked flame.
- Store spare gas cylinders in the cabinet.
- Lay the gas cylinder down (always keep upright).
- Use appliance indoors.
- Modify the constructions of the appliance or the size of any burner, injector orifice or any other components.
- Move the appliance during using.
- Obstruct any ventilation of the appliance.
- Allow the flexible gas supply hose or any electrical cord to come in contact with any heated surface of the appliance.
- Use charcoal or any other solid fuel in this appliance.
- Disconnect any gas fittings while the appliance is in using.
- Use a rusty or dented gas cylinder with a damaged gas valve.
- Fill the gas cylinder beyond 80% capacity.

- Gas Category

This appliance is only for use with low-pressure butane, propane or their mixture gas and fitted with the appropriate low-pressure regulator via a flexible hose. The appliance is set to operate:

- 28-30 mbar regulator with butane gas @ category I3+.
- 37mbar regulator with propane gas @ category I3+.
- 37 mbar regulator with butane, propane or their mixtures @ category I3B/P(37).
- 30 mbar or 50mbar regulator with butane, propane or their mixtures @ category I3B/P(30) or category I3B/P(50) respectively.

CAUTION: ONLY THE GAS TYPE AND GAS CATEGORY LISTED IN THE RATING LABEL COULD BE USED ON YOUR APPLIANCE.

- Gas Hose and Gas Regulator

Use only regulator and hose approved for LP Gas at the correct pressures.

The pressure adjuster should comply with the standard EN12864 and current regulations in the country where it is installed, which may be found at your nearest retailer of gas items. Refer to the technical data. It is strictly prohibited

to use adjustable pressure. It is recommended that the regulator is changed within 10 years of the date of manufacture or the national conditions require it.

The type of replaceable hose should meet the standard of EN1763-1-Class 3. The hose used must conform to the relevant standard for the country of use. The length of the hose must be 0.7 meters (minimum) and 1.5 meters (maximum). Worn or damaged hose must be replaced.

Ensure that the hose is not obstructed, kinked, or in contact with any part of the appliance other than at its connection. It is recommended the hose is changed within 1 year of the date of manufacture or the national conditions required. During serving or installation, make sure that the connection flexible tube is not subjected to twisting.

CAUTION: THE APPLIANCE IS ATTENDED TO BE USED WITH REGULATOR AND HOSE ASSEMBLY. IF THEY ARE NOT SUPPLIED BY MANUFACTURER, THE USER MUST CHOOSE THE AUTHORIZED REGULATOR AND HOSE COMPLYING WITH THE STANDARD AND LOCAL REGULATIONS.

- Storage of Appliance

When the appliance is not in use, storage indoors is only permitted when the cylinder is disconnected and removed from the appliance. When the appliance is not to be used for a period of time, it should be stored in its original packaging and stored in a dry and dust free environment.

- Gas Cylinder

The gas cylinder should not be dropped or handled roughly! If the appliance is not in use, the cylinder must be disconnected. This precaution needs to be taken when changing the gas cylinder which shall be carried out away from any source of ignition.

Cylinders must be stored outdoors in an upright position and out of the reach of children. The cylinder must never be stored where temperatures can reach over 50°C. Do not store the cylinder near flames, pilot lights or other sources of ignition.

CAUTION: THE APPLIANCE IS SUITABLE WITH A GAS CYLINDER OF 5 KG INSIDE, WHEN IN USE.

- Connection to the Appliance

Before connecting, please ensure there is no debris caught in the head of the gas cylinder, regulator, burner or in any burner parts. If the hose is replaced, it must be secured to the appliance and regulator connections.

After connecting, **GAS LEAKAGE CHECKING** is a must. Please follow the following method to check for gas leakage.

- Ensure the control valve is "OFF".
- Connect the cylinder to the regulator, regulator to hose and hose to the appliance, ensure the connections are secured, then turn ON the gas.
- Brush the soapy water on the hose and all joints. If bubbles appear, it means there is a leakage. This means that you must reconnect or replace the gas leakage part or joint.
- Re-test after fixing the fault. Turn OFF the gas at the cylinder after testing.

CAUTION: IF LEAKAGE IS DETECTED AND CAN NOT BE FIXED, DO NOT ATTEMPT TO CURE LEAKAGE BUT CONSULT YOUR GAS DEALER.

- Lighting the Appliance

1. Open the lid and make sure all the knobs are in the OFF (●) position.
2. Push down the knob and turn the knob anticlockwise to HIGH (🔥) position, then keep pressing the igniter for 2-3 seconds (a sound could be heard), thus the burner could be lit. If the burner does not light, turn off the knob and wait for 5 minutes then repeat this process.
3. Adjust the heat by turning the knob to the High (🔥)/Low (🔥) position. INFRARED REAR BURENR IS ONLY IN HIGH POSISTION.
4. To light other burners, repeat the same process for the adjacent burner and continue in sequence until all the burners are lit.
5. To turn the barbecue OFF, turn the cylinder valve or regulator switch to the "OFF" position and then turn all of the control knobs on the barbecue clockwise to the "OFF" (●) position.

For Match- Lighting:

1. Follow above instruction step 1-3.
2. For Main burner, place the match into match holder chain and fire the match, then put the match into the lighting hole on the right side of the fire box;

* For side burner, place the fired match on the holes of the side burner head.
3. Push down and turn the knob anticlockwise to HIGH (🔥) position, then the burner could be lit. If the burner does not light, turn off the gas tap and wait for 5 minutes then repeat this step 2-3.

The side burner is designed for pot/pan with diameter 180-260mm. Side burner lid can not be used as work table, do not put anything on the side burner lid while it is not working.

Before cooking for the first time, light all the main burners and keep burning for 15 minutes with the lid closed and knob at HIGH (🔥) position. This will "heat clean" the internal parts and dissipate odor from the painted finish. The color of the cooking area may get a little changed. It is normal and is the nature of the material.

- Clean and maintenance

All cleaning and maintenance should be carried out when the appliance is cool and with the fuel supply turned **OFF** at the gas cylinder after use.

DO NOT mistake brown or black accumulation of grease and smoke for paint. Interiors of gas grills are not painted at the factory (and should NEVER be painted). Apply a strong solution of detergent and water or use a grill cleaner with scrub brush on insides of grill lid and bottom. Rinse and allow to completely air dry.

DO NOT apply a caustic grill / oven cleaner to painted surfaces.

DO NOT use abrasive or flammable cleaners, as it will damage the parts of the product and may start a fire.

Stainless steel surfaces: Stainless steel will get rust if not maintained well. To maintain your grill's high quality

appearance, wash with mild detergent and warm soapy water and wipe dry with a soft non-abrasive cloth after each use. Use stainless steel protection liquid like WD-40 on the surface to avoid rust.

Cooking grid: Use a mild soapy water solution. Non-abrasive scouring power can be used on stubborn stains then rinse with water.

Cleaning the burner assembly

Follow these instructions to clean:

1. Turn gas off at control knobs and LP Tank.
2. Remove cooking grates, grease tray and grease cup.
3. Remove screw at end of burner using a screwdriver.
4. Carefully lift each burner up and away from valve openings.
5. Wire brush entire outer surface of burner to remove food residue and dirt.
6. Clean any blocked ports with a stiff wire such as an open paper clip.
7. Check burner for damage, due to normal wear and corrosion some holes may become enlarged. If any large cracks or holes are found replace burner.
8. Carefully refit burners.
9. Replace screw at the end of burner.
10. Replace grease tray and cooking grates.

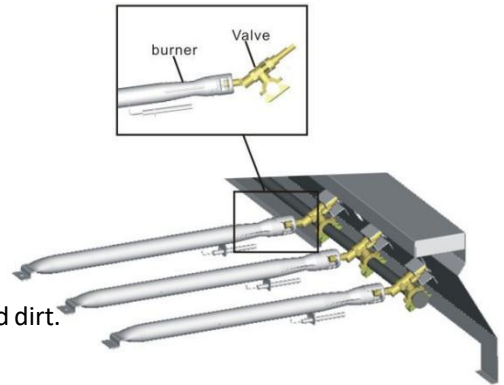

Inspect burner for any damage (cracks or holes). If damage is found, replace with a new burner. Reinstall the burner, check to ensure that the Gas valve orifices are correctly positioned and secured inside the burner inlet. We suggest three ways to clean the burner tubes. Use the one easiest for you.

(A) Bend a stiff wire (a lightweight coat hanger works well) into a small hook. Run the hook through each burner tube and burner several times.

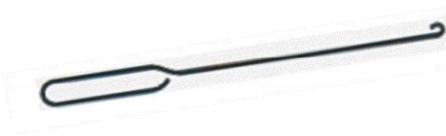

(B) Use a narrow bottle brush with a flexible handle (DO NOT use a brass wire brush), run the brush through each burner tube and burner several times.

(C) Wear eye protection: use an air hose to force air into the burner tube and out the air ports. Check each port to make sure air comes out each hole.

⚠ CAUTION

NATURAL HAZARD SPIDERS

FACT: sometimes spiders and other insects climb into the grill tubes attached to the burners. The spiders spin webs, build nests and lay eggs. The webs or nests can be very small, but they are very strong and can block the flow of gas.



Clean burners prior to use after storing, at the beginning of grilling season or after a period of one month not being used.

Spider guards are on the air intakes in an effort to reduce this problem, but it will not eliminate it! An obstruction can result in a “flashback” (a fire in the burner tubes). The grill may still light, but the obstruction does not allow full gas flow to the burners.

TROUBLE SHOOTING

Problem	Possible Cause	Prevention/Solution
Burner(s) will not light.	<ul style="list-style-type: none"> • No gas flow. • Coupling nut and regulator not fully connected. • Obstruction of gas flow. • Disengagement of burner to valve. • Is grill assembled correctly. 	<ul style="list-style-type: none"> • Check to see if LP tank is empty. • Turn the coupling nut about one-half to three quarters additional turn until solid stop. Tighten by hand only-do not use tools. • Clear burner tube(s). • Reengage burner and valve. • Check steps in assembly instructions.
Sudden drop in gas flow or low flame.	<ul style="list-style-type: none"> • Out of gas. • Excess flow valve tripped. 	<ul style="list-style-type: none"> • Check for gas in LP tank. • Turn off knobs, wait 30 seconds and light grill. If flames are still low, turn off knobs and LP tank valve. Disconnect regulator. Reconnect regulator and leak test. Turn on LP tank valve, wait 30 seconds and then light grill.
Flames blow out.	<ul style="list-style-type: none"> • High or gusting winds. • Low on LP gas. • Excess flow valve tripped. 	<ul style="list-style-type: none"> • Turn front of grill to face wind or increase flame height. • Refill LP tank. • Refer to "<i>Sudden drop in gas flow</i>" above.
Flare-up.	<ul style="list-style-type: none"> • Grease buildup. • Excessive fat in meat. • Excessive cooking temperature. 	<ul style="list-style-type: none"> • Clean grill. • Trim fat from meat before grilling. • Adjust (lower) temperature accordingly.
Persistent grease fire.	<ul style="list-style-type: none"> • Grease trapped by food buildup around burner system. 	<ul style="list-style-type: none"> • Turn knobs to OFF. Turn gas off at LP tank. Leave lid in position and let fire burn out. After grill cools, remove and clean all parts.
Flashback... (Fire in burner tube(s)).	<ul style="list-style-type: none"> • Burner and/or burner tubes are blocked. 	<ul style="list-style-type: none"> • Turn knobs to OFF. Clean burner and/or burner tubes.

Technical Information

Appliance Name	OUTDOOR DOUBLE SIDE BURNER		CE 2531CU-0070	
Model No.	UU020C-PKN-1 / SUNC-DSB7641S / SUNC-DSB7909BLACK / SUNC-BIDSB7920S		UU020C-PKN-1/ SUNC-DSB7910S-GER / SUNC-DSB7911BLACK-GER / SUNC-BIDSB7921S-GER	
Appliance Category	I3+(28-30/37)	I3B/P(30)	I3B/P(50)	
Type of Gas	Butane	Propane	Butane, Propane or their mixtures	Butane, Propane or their mixture
Gas Pressure	20-30mbar	37mbar	30mbar	50mbar
Heat input	Side burner: 3.2kW X2		Side burner: 3.2kW X2	Side burner: 3.2kW X2
Total Heat Input (Qn)	6.4kW		6.4kW	6.4kW
	(466 g/h)		(466g/h)	(466g/h)

0.93mm indicates the diameter of the injector.

ASSEMBLY INSTRUCTIONS

Tools required:

1. Screwdriver
2. Gloves (if necessary)

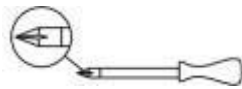

EXPANDED VIEW

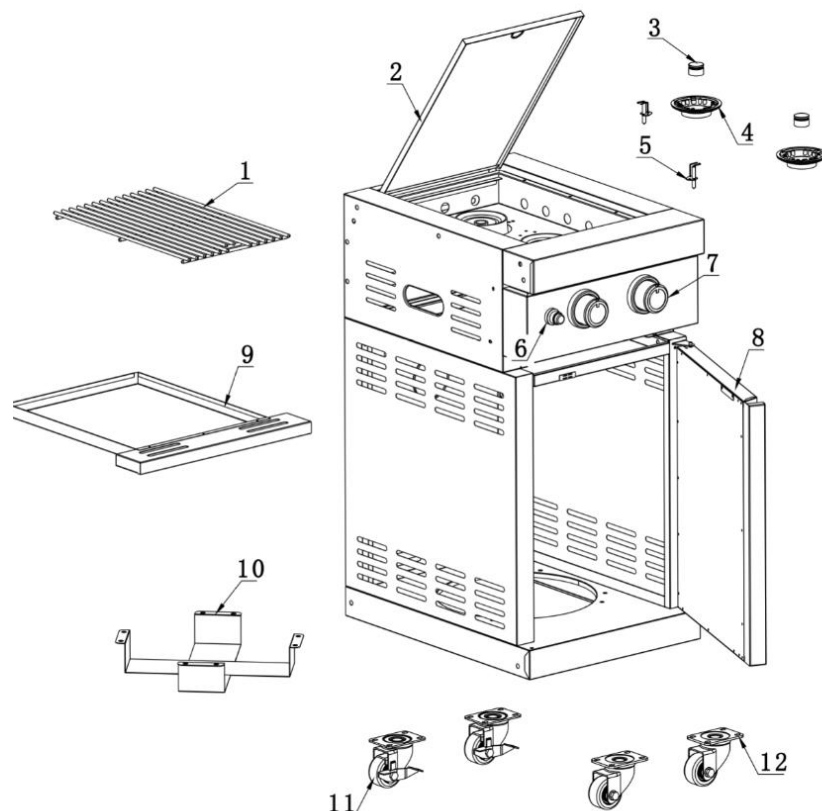

1. Gas Cylinder bracket assembly

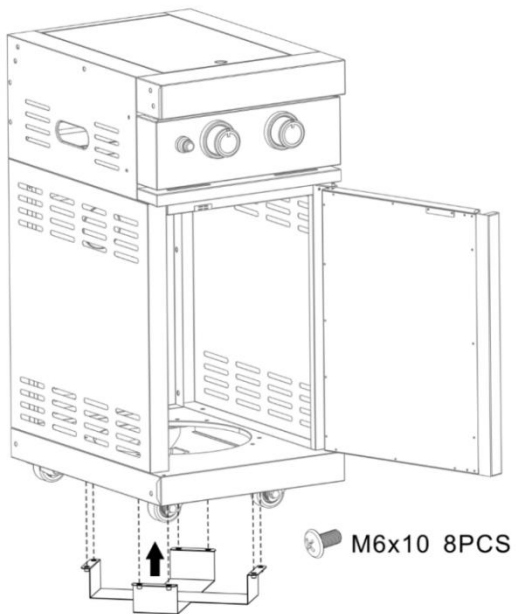

2. Cooking grid and Grease tray

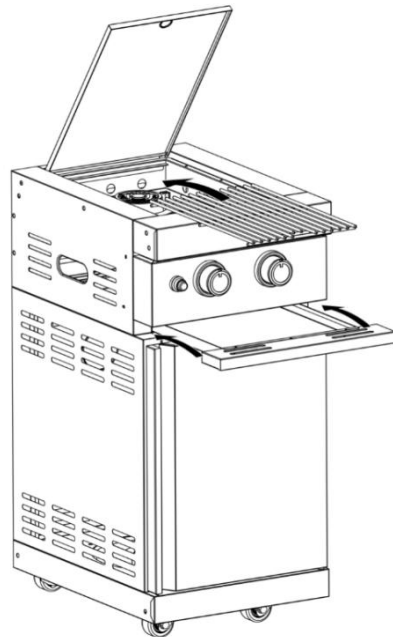

3. Battery assembly for ignition (Battery is not included in this appliance.)

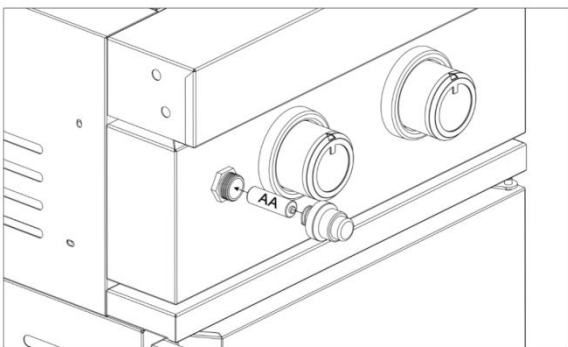

4. Only gas cylinder 7 kg or less could be placed inside the cabinet for using

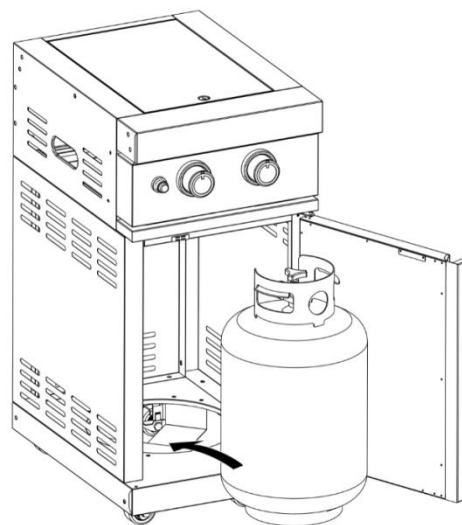

5. Connection with the main BBQ gas grill

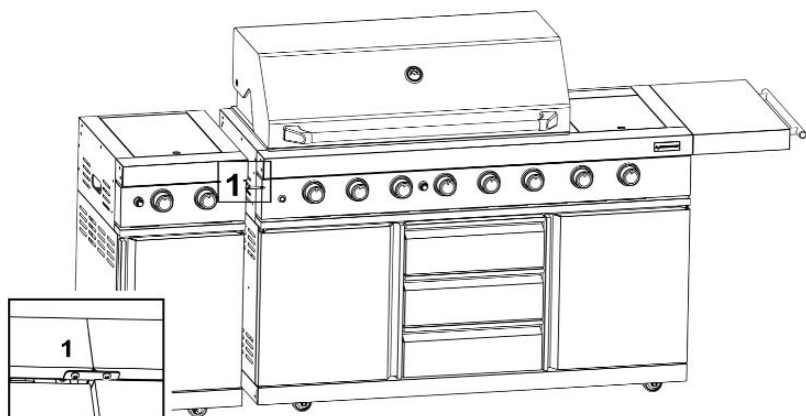

 M4x8 2PCS

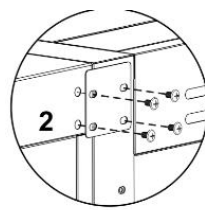
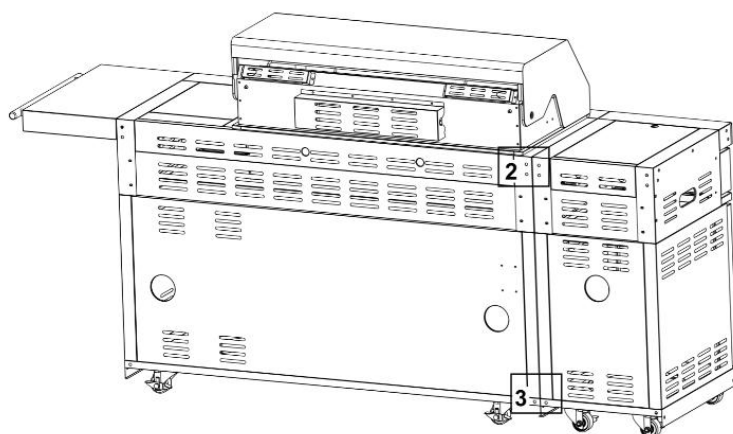

 M6x10 6PCS

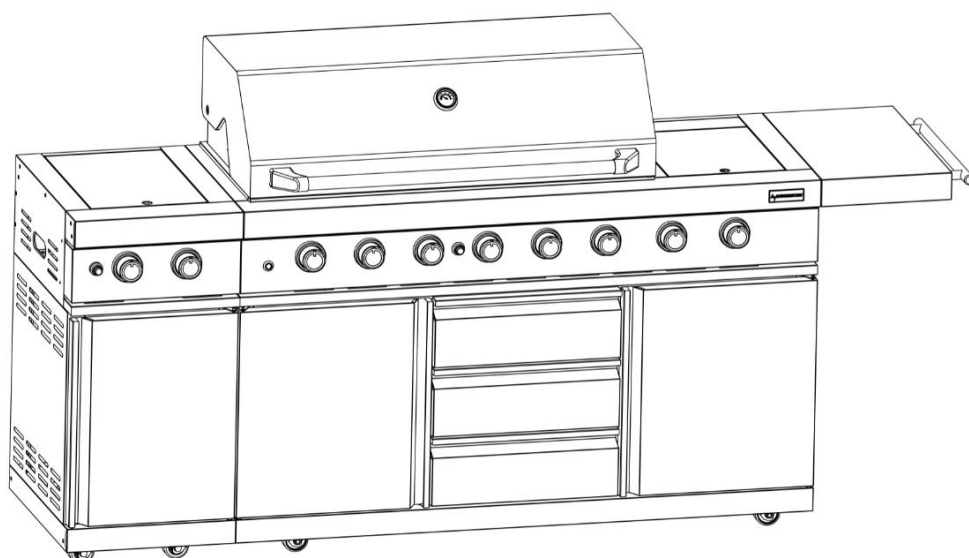
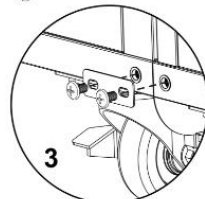

6. Connection with the sink cabinet

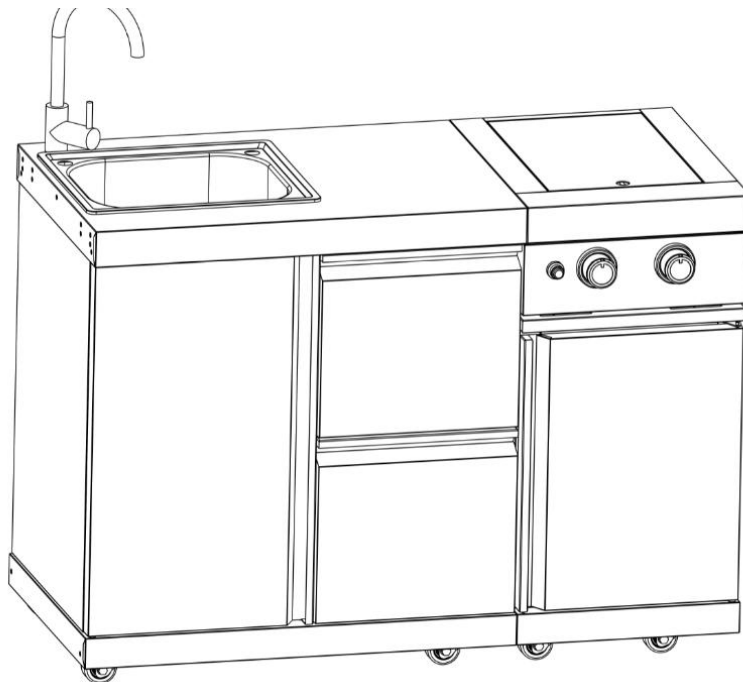
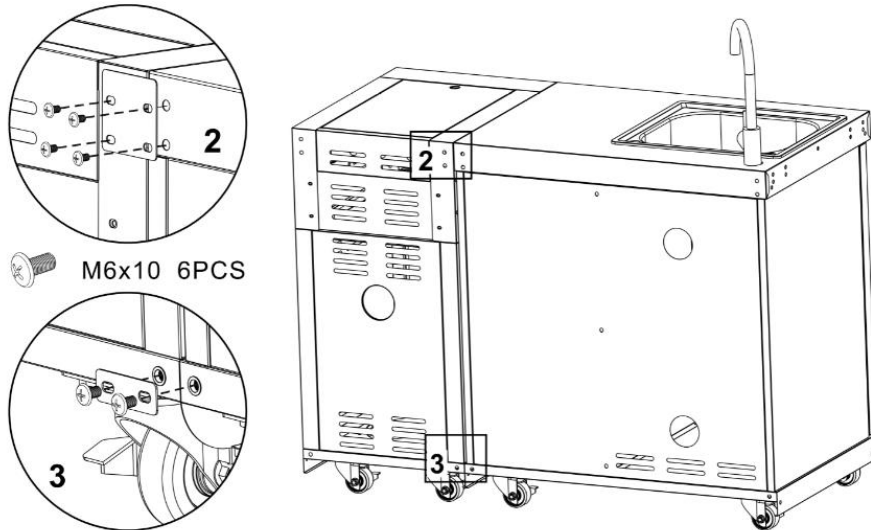
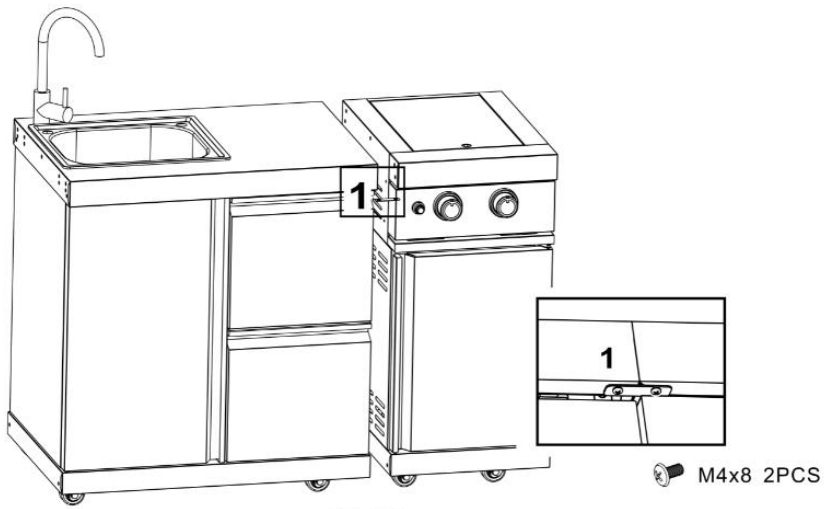

7. Connection with the BBQ grill and the sink cabinet

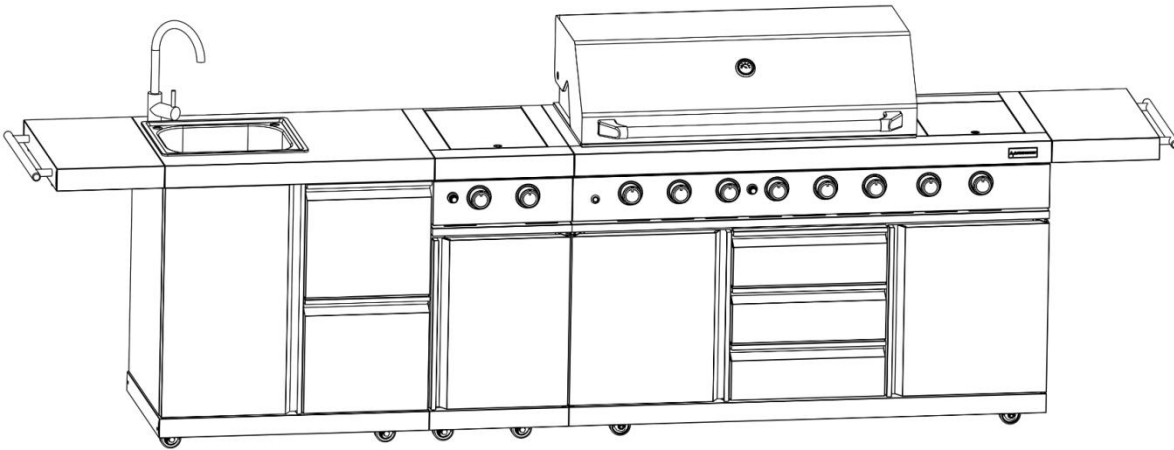

8. For models: SUNC-BIDSB7920S/ SUNC-BIDSB7921S-GER

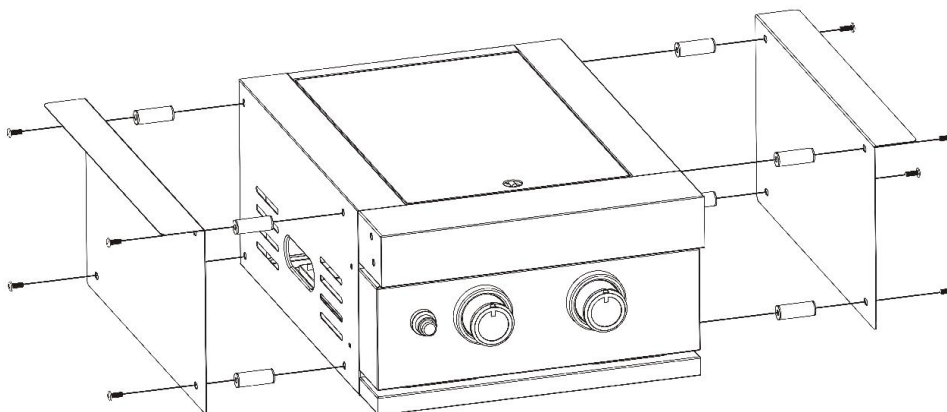

 M6x60 8PCS