



PRO CHARGER

Installation Guide



1 X 22KW / 2 X 11KW DUAL WALL CHARGER:

EVPCFSM211NBGR (No Light / Wi-Fi / LAN / 4G / RFID)

EVPCFSM211NBGRP (No Light / Wi-Fi / LAN / 4G / RFID / Payment Terminal)

EVPCFSM211LBGR (Light / Wi-Fi / LAN / 4G / RFID)

EVPCFSM211LBGRP (Light / Wi-Fi / LAN / 4G / RFID / Payment Terminal)

Contents

[click to navigate directly to the page](#)

[Introduction / Box contents](#)

[Safety information](#)

[Installation & testing](#)

[Troubleshooting](#)

[Commercial Installation & Commissioning](#)

[Domestic Commissioning
Stage 1 \(Installer app\)](#)

[Domestic Commissioning
Stage 2 \(User app setup\)](#)

[Technical](#)

Introduction

This guide is intended for use by competent electrical installers to explain basic requirements and options to be considered when installing a Sync Energy charger. The unit is designed for installations inside or outside, the advanced safety technology we have built into the unit ensures its safe usage. This guide provides information to assist when installing the Pro Charger Range of EV chargers and should not be used with other EV chargers.



Box contents

- EV charger
- Decorative fascia
- Quick start guide
- Accessories pack containing:
 - » Assembly screws
 - » Anti-tamper bit
 - » x2 RFID Key fob (Additional key fobs can be ordered using the code EVXRFIDFOB-01)
 - » **Note** – Compatible with CT Clamps & Balancer supplied by Sync Energy

Tools required

Hex bit holder, PZ2 & Flat Blade Screwdriver, suitable drill bit, 4mm Hex Key for terminals and fixings.

Safety information

Warning: The supplied Sync Energy charger is manufactured to be safe without risk provide they are installed correctly, used, and maintained in accordance with the manufacturers recommendations and installed by a competent electrical installer in accordance with national and local regulations and legislation applicable at the time of installation, e.g. BS7671:2018 amendment 3.

The EV charger should be connected to a three phase (for up to 22kW charging) 400V/415V nominal AC supply.

The supply should run from a dedicated circuit breaker for EV Charging between 40-130A. We recommend the use of a Type B curve circuit breakers. The EV charger features an integral 30mA type-A RCD with 6mA DC leakage detection and therefore an external RCD is not usually required:

1. For cables without earthed metallic covering installed in walls or partitions at a depth of less than 50mm and also within walls and partitions with metal parts, and not protected by steel conduit or similar then RCD protection is required.
2. If the cable is clipped directly to the surface of a wall and does not pass through a wall or partition to the EV charger then a standard MCB may be installed into the Consumer unit, however RCD protection may be required for other reasons such as if it forms part of a TT system and the earth fault loop impedance values cannot be met. This will

be in compliance with the current BS7671 Amendment 2 Wiring Regulations. To conform with BS 7671, on occasions a four pole MCB/RCD or other means of isolation may be required.

Important note: A DC Leakage fault in the vehicle may "blind" a type "AC" RCD and render it ineffective, never feed any EVSE From an upstream Type "AC" RCD.

Earthing requirements

The supplied EV charger features an on-board safety monitoring system to detect low or high voltage supplies and potential earth-neutral faults, this in accordance with regulation 722.411.4.1 (iv) of BS7671 2018. If such a condition is encountered the charge cycle is ended or prevented and the EV charger indicator flashes red and effectively becomes a double insulated (class II) device. The vehicle becomes isolated in accordance with Regulation 543.3.3.101(ii) from incoming supply and poses no risk to touch. This feature removes the requirement for an earth electrode where it may be ineffective or introduce further risk.

The EV charger may be connected directly to a TN-C-S (PME) earthing system without any special arrangements. It remains the responsibility of the installer to conduct a risk assessment of the immediate area to a range of 10 meters (equipotential zone) to ensure no other conductive metal fixings pose risks (mixture of TT/TN-S and TN-C-S), this is important where cable length may enable charging inside or outside of a building/garage where the vehicle is within touch distance.

Where certain conditions dictate an earth electrode must be used it shall be independent from the distributors earth system with no direct interconnection (the incoming supply SWA protective earth should be isolated from the housing and/ or earth electrode). The electrical installer shall install a suitable electrode complete with termination housing and covers where appropriate, warning labels should be visible and close to the unconnected SWA protective earth, e.g. inside the charger.

The earth connection shall be made from the electrode to the charger via copper conductor earth wire of an appropriate CSA for the installation. The earth wire shall be installed in conduit where there is a risk of mechanical damage or UV exposure. Recommended Earth electrode impedance to be <100 ohms.

Isolation and switching for safety and maintenance

To ensure the EV charger can be "turned off" to enhance security and enable maintenance activities, a four pole isolator (or 4P RCD or RCBO) suitably rated must be installed within the customer's property.

Installation requirements

The EV charger is suitable for installation inside and outside on a solid structure.

It is recommended the charger is installed flush to the ground and not on a raised plinth to conform with PAS:1899 regulation heights.

It is recommended the charger is installed at a height of 500mm-1500mm as per building regulations BS8300:2018.

Ensure suitable fixings are used depending on the mounting surface. To avoid unnecessary dust inside the enclosure, it is recommended to use the base mount separated from the charger as a template to drill the surface.

Ensure installation foundations has been checked for electric cabling or pipework with a suitable detector.

NOTE: if any groundworks are required e.g. cable trenching or earth electrode fitment, it is advisable to check if underground services could be present before commencement. Plans may be available at: www.linesearchbeforeudig.co.uk (free to domestic users).

The EV charger is suitable for bottom cable entry, when using bottom cable entry ensure the rubber gasket is used to maintain the IP rating.

When using Loop In / Loop Out installation method use one of the bottom cable entry points to link to the next charger.

Do not drill alternative cable entries into the charger housing.

We recommend using Power & Data Combined cable on installs that require a CT clamp or Balancer to use the chargers dynamic load management capabilities.

All of the cables that are to be connected into the supply connector should have their insulation striped back 18-20mm. Connectors supplied are suitable for cables of 50mm².

Load balancing

If load balancing is required, three CT clamps will be required for correct balancing on three phase power. We suggest the use of Sync Energy CT clamps, EVA120CT1 or EVA400CT1 depending on cable incoming size (Not supplied). These should be fitted around the incoming power to the main fuse and the correct max load (A) to be entered during setup and installation steps.

Load Balancing Multiple chargers

If load management for more than 1 charger is required please see EV Balancer at sync.energy for more details on how to dynamic load manage up to 16 chargers at once.

MID Meter For Billing Purposes Only

MID Meters are built into the charger as standard and report their usage on the charger screen, alternatively the MID meters have a screen which can be viewed internal of the product.

Final Electrical testing

To meet the BS7671:2018 (18th edition) requirements for testing of an electrical installation, the following tests and checks shall be performed by a competent electrical installer before during and after a Sync Energy charger is installed:

- A visual inspection of the installation including the existing electrical installation
- Verification of the characteristics of the electrical supply at the origin of the installation to confirm the supply is suitable for the additional load

- A test to confirm the continuity of the circuit protective conductors
 - A test to confirm the integrity of the circuit insulation resistance
 - A test to confirm the polarity of the installation is correct
 - Where applicable a test to confirm the earth electrode resistance is within acceptable tolerances
- (or)
- An earth loop impedance test
 - A test of the mechanical operation of residual current devices (RCD's)
 - A test to confirm the operation of residual current devices (RCD's) is within stipulated time scales (at the rated current and at five times the rated current operating current)
 - A test or calculated measurement of the prospective fault current
 - A verification of the functional operation of the EV charger
 - An electrical installation certificate must be completed

Ensure electrical testing is done before EV charger commissioning and network setup is performed.

For this testing, the Charger can be set to **"Installation Mode"** in the installation App.

Electrical Installation

- 1 Isolate the power.



- 2 Use the base plate as a template for fixings holes, ensuring the front of the base is the correct orientation.

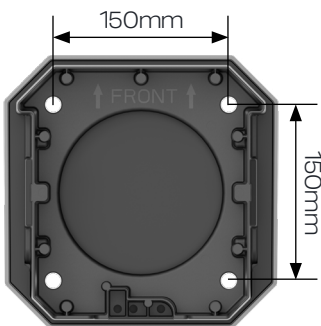

- 3 Remove top and bottom screws and remove inner cover.



4

Cut the rubber gasket to suit the cables, use supplied brass gland plate when installing as loop in loop out cable method.



5

Fit the charger to the base plate ensuring to use 3 side screws on either side to secure the charger.

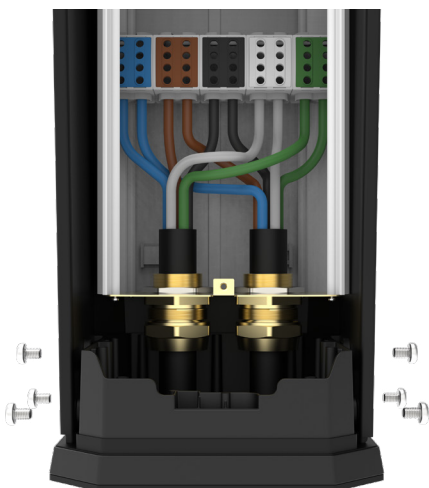
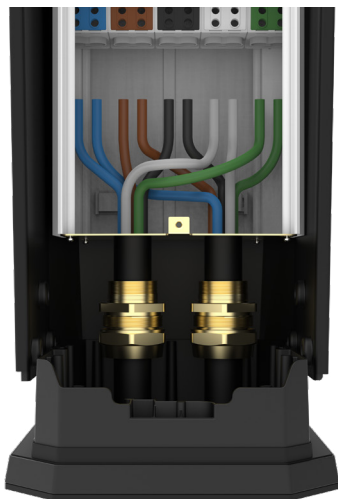

6

Ensure correct polarity when making incoming power connections.



7

For dynamic load balancing, insert wires into the small connector.

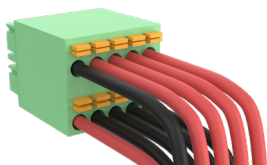

For Use with the Balancer connect into 485.

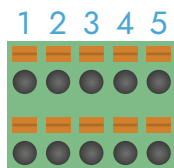

	1	2	3	4	5
485B-	PV+	CT PH1+	CT PH2+	CT PH3+	
485A+	PV-	CT PH1-	CT PH2-	CT PH3-	

8

Plug connector into PCB, ensure correct polarity.

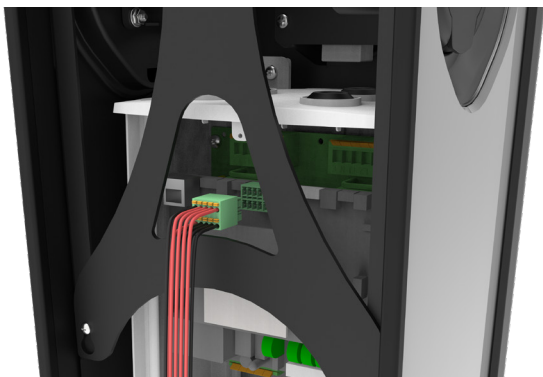

9

Refit inner cover and top and bottom screws.

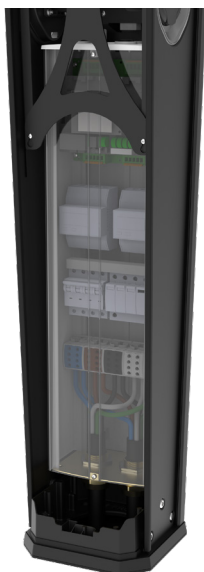

10

Remove the adhesive tape protective film, and fit the fascia side plates to the charger.



11

Once all connections are done and secure, fit the rear cover to the charger, slide the top in and up first before pushing the bottom half of the door to close.



12

Lock the bollard using key provided.

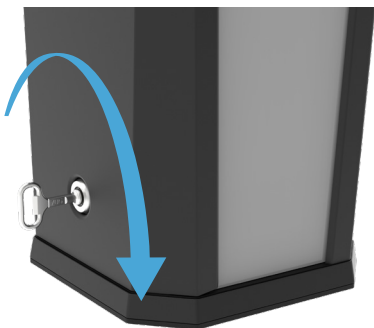

Commissioning Stage 1 of 2

INSTALLER APP – [Download the 'SyncEnergy' app by clicking this link](#)

Also available from the Installer Portal on the [sync.energy website](#), or using the QR code opposite.



Intuitive Interface: The revamped interface is designed with the installer in mind. Everything you need is available through a new side-menu

Effortless Setup: seamlessly configure your EV Chargers and balancer devices with just a few taps. Get up and running in no time

Account Management: Create and manage your account effortlessly. Keep a history of all your installed Chargers.

Upon Powering the charger, the status indicator light will show Yellow. This indicates that the charger is ready for network setup but is not yet connect to the internet. These steps are still required for 4G connected versions for setting of Dynamic Load Management.

Please ensure your Wi-Fi network operates on the 2.4Ghz band.

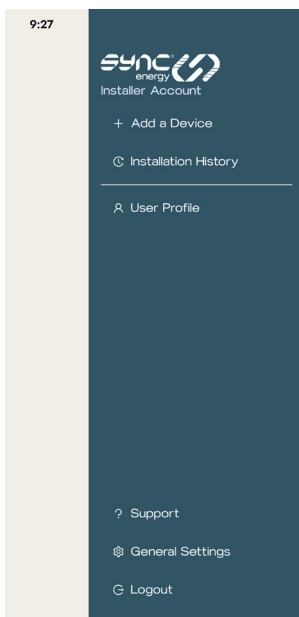

- 1 Browse to the main menu and press "Add a device".

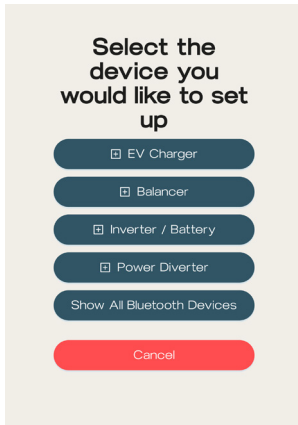

- 2 Select "EV Charger"

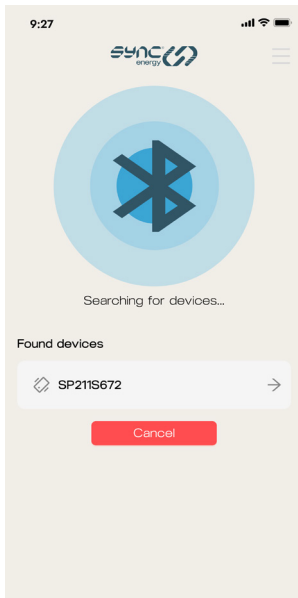

- 3 The device ID should display on screen. If it does not, go back and search again. Press on the device.

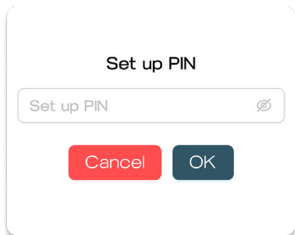

- 4 When asked for the set up PIN, enter it. This can be found inside the device, and also on the in-box paperwork.

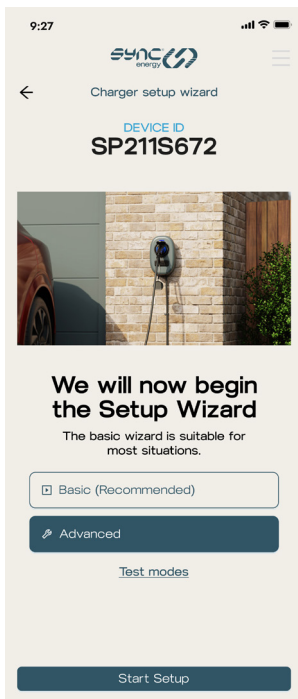

- 5 The "Advanced" wizard is the recommended selection for Sync Energy Pro Chargers. Select "Advanced" and press "Start Setup".

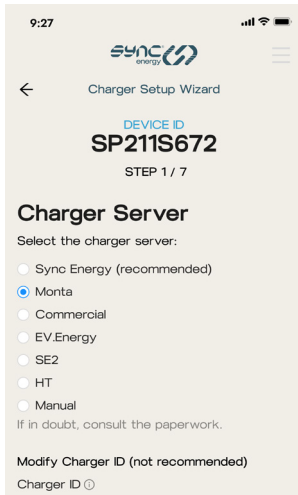

- 6 The Charger server should be pre-set to "Monta". This is the default choice for chargers in non residential (commercial) settings.

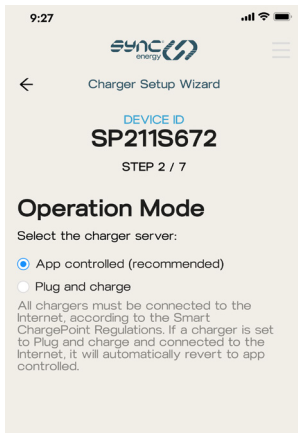

- 7 Leave the Operation Mode as "App controlled".

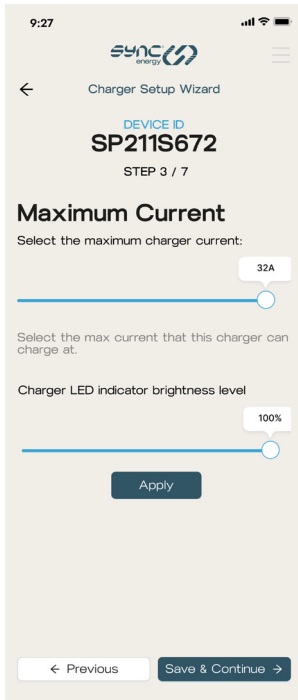

8

Set the maximum current that the chargepoint can deliver. Please note that if there are two vehicles connected and it has been set to 32A, then the device will provide 16A to each device.

The LED indicator brightness level can also be set here. Please note that the brightness may be perceived differently when it is dark, compared to when there is daylight.

CT Meter

Is the CT clamp being fitted?

Yes (recommended)
 No

Select whether a CT clamp is being fitted, allowing dynamic load management to the property.

Configuration

Single CT Clamp
 Twin CT Clamp
 3Phase, CT Hub
 Meter

9

CT Meter Installation and Configuration

To enable dynamic load management (DLM) and prevent overloading the site’s main fuse, you must install a CT clamp. Select ‘Yes’ (recommended) to activate DLM. Then, specify the Configuration that reflects the CT clamp installation on site: Single CT Clamp, Twin CT Clamp, 3-Phase CT Hub, or Meter.

Maximum home current

100A

This is typically the rating of the main home fuse

Maximum Property Current (Main Fuse Rating)

Set the main fuse rating for the property (e.g.100A). The charger uses this maximum current value to perform safe, compliant load balancing in accordance with BS 7671.

Balancer Setting

Multi-charger Management

Phase Rotation

Balancer Setting

Activate Multi-charger Management if this unit is part of a larger, managed network of chargers connected to a single point of measurement. Select the correct Phase Rotation to ensure balanced power distribution across the system.

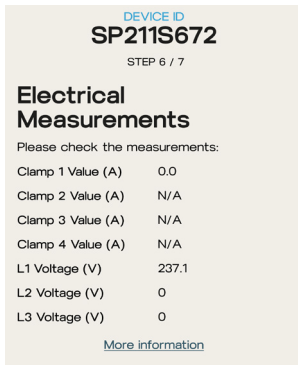

- 10 Check the electrical measurements on-screen. These may differ depending on whether the device is being used in a single or a three phase setup.

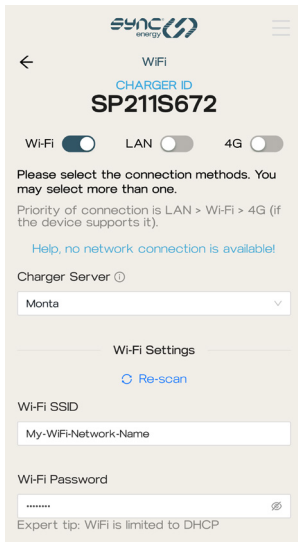

- 11 Select the method that the device will connect to the Internet. For Wi-Fi, enable the option and use the on-screen options to select the Wi-Fi SSID (name), and enter the password.

CHARGER ID
SP211S672

Wi-Fi LAN 4G

Please select the connection methods. You may select more than one.
Priority of connection is LAN > Wi-Fi > 4G (if the device supports it).

Charger Server ⓘ
Monta ▼

Wi-Fi Settings

[Re-scan](#)

Wi-Fi SSID
My-WiFi-Network-Name

Wi-Fi Password
..... ⓘ

Expert tip: WiFi is limited to DHCP

4G Settings ⓘ

4G APIN
iot.1nce.net

4G Account
user

4G Password
pass

12

If the unit has 4G, then this can also be enabled. Typically, the settings are auto-filled and should be left as they are.

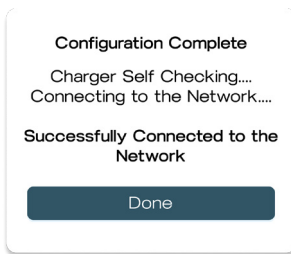

13

When network setup is complete, the system will run a series of checks. If everything is ok, then the following message will show.

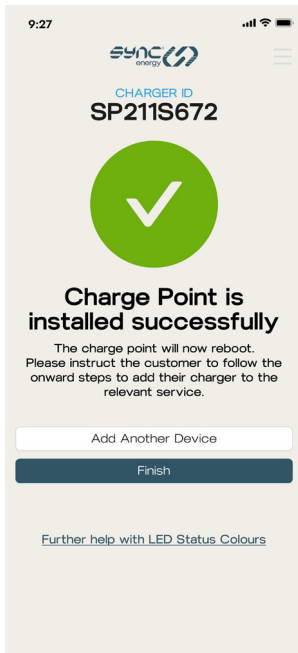

14

After all the steps have been completed, the charge-point has been successfully commissioned. The Monta app should now be used to continue setup (See the section "Commercial App Commissioning" - Stage 2 of 2).



In less than 2 minutes, the indicators should turn from Yellow to Blue to confirm network connection.

If the charger continues to show yellow, power cycle (switch off/on at fuse board) and reconnect via the app to check the settings are correct.

If still unable to connect to the network but need to use the charger then change the Charge Mode to '**Plug and Charge**' and press '**SET**' again to re-update settings.

If unable to establish network connection call **01952 983 940**
or email: support@sync.energy

Note: The network connection from the device to the Internet is fully encrypted and secure. Additionally, no user data is stored on the charger.

Commercial App Commissioning Stage 2 of 2

- 1 Download the Monta smart app:

[Apple app store
click here](#)



[Google play store
click here](#)



or search for '**Monta EV charging**' on
Apple app store or Google Play

- 2 Using your smart-phone scan the unique
Monta QR Code on the '**Quick Start Guide**'
sheet supplied with the EV Charger.
If you're unable to use the QR, open a web
browser on your smart-phone and manually
type the URL on the sticker

- 3 Open the Monta app

iOS

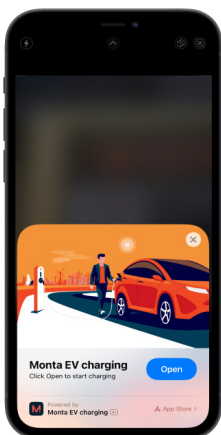

Android

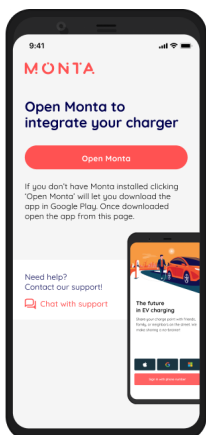

4

Create an account using your customers phone number or social logins (Apple/Google/Microsoft)

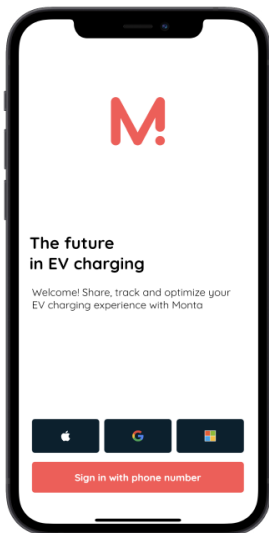

5

Connect the EV charger to Monta – select the socket outlet, name the charge-point and set the location

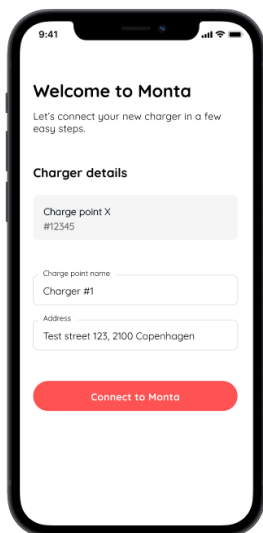

- 6 Successful connection – When you reach this step, repeat for the second socket outlet

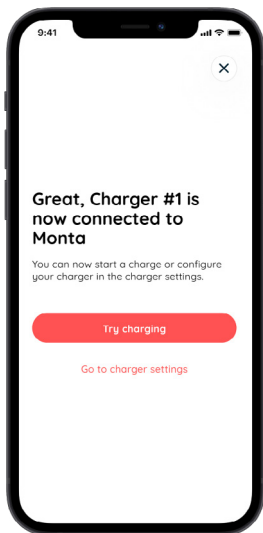

- 7 Once both sockets are connected your charge-point is fully integrated and you can use Monta to start charging

Need help with the app?

Contact Monta customer support through the app or via the website [Monta.com](https://www.monta.com)

Need help with the charge-point?

Contact Sync Energy technical support at: support@sync.energy or via the website at www.sync.energy

Commercial usage with Billing installation & commissioning

Sync Energy can handle all management and set up for customers including setting up single or multi pricing / time of day usage tariffs and Payment Terminal set ups.

4 simple steps:

1 CONTACT

Email commercial@sync.energy with the charge-point owner contact details

2 CONNECT

Install the charge-points

3 CONFIGURE

Set the configurations in the Sync Energy installer app and connect all chargers to the internet

4 COMPLETE

Pass the charger details to the charge-point owner

How it works:

To streamline the process, email us [before the first day of installation](#) with the following information:

- **Model and charger ID**
(for every charger in the installation)
- **Payment Terminal SN/s**
(Where Applicable)
- **Contact details for the charge-point owner:**
 - Company name
 - Name of charge-point manager
 - Site address
 - Telephone number for charge-point manager
 - Email address for charge-point manager

Our Commercial Team will contact the charge-point owner to carry out the quick and simply Monta setup process.

By using this process we will have the back-office set up for installation day, ensuring all chargers are immediately ready for customer use once configured.

Technical information

Environmental Protection

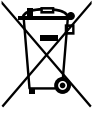

This symbol is known as the "Crossed-out Wheeled Bin Symbol". When this symbol is marked on a product or battery, it means that it should not be disposed of with your general household waste. Some chemicals contained within electrical/electronic products or batteries can be harmful to health and the environment. Only dispose of electrical/electronic/battery items in separate collection schemes, which cater for the recovery and recycling of materials contained within. Your co-operation is vital to ensure the success of these schemes and for the protection of the environment.

Guarantee

Sync Energy products are guaranteed against faulty materials and workmanship for a period of 5 years from date of delivery: products will be repaired or (at Sync Energy's discretion) replacements will be supplied or (at Sync Energy's discretion) a credit note will be issued.

This guarantee is subject to Sync Energy's conditions of sale and in particular to the following conditions being met:

1. Notification of any defect is given to Sync Energy as soon as reasonably practicable after becoming apparent, and the products then returned to Sync Energy.
2. The products have only been operated under normal operating conditions and have only been subject to normal use.
3. No work (other than normal and proper maintenance) has been carried out to the products without Sync Energy's prior written consent.
4. The products have been assembled, or incorporated into other goods, by a qualified and recognised electrician and only in accordance with any instructions issued by Sync Energy.
5. The defect has not arisen from an item manufactured or supplied by a person other than Sync Energy.
6. 5 year warranty as standard, optional product registration can be completed on the Sync Energy website.

[Follow this link to visit our Warranty web-page](#)



Technical data

PART NO:	EVPCFSM211LBGR Floor Mounted with 4G, MID Meter & Light - Three Phase EVPCFSM211LBGRP Floor Mounted with 4G, MID Meter, Light & Payment Terminal - Three Phase EVPCFSM211NBGR Floor Mounted with 4G, MID Meter - Three Phase EVPCFSM211NBGRP Floor Mounted with 4G, MID Meter & Payment Terminal - Three Phase
SOCKET TYPE:	Type 2 with Autolock
MAX OUTPUT:	1 x 22kW or 2 x 11kW, 32A
MAX INPUT:	130A, 400-415V
TO SPECIFY:	Floor Mounted, Twin Type 2 Socket, EV Charging Bollard with Touchscreen, 4G connectivity, RFID and Contactless card payment options. Compliant with PAS 1899:2022 accessibility standards, equipped with MID meters, RCD Built in protection, MCB over current protection, PEN fault protection and Loop in Loop out input terminations up to 50mm ² cable, with IP65 and IK10 rating. Made of stainless steel and Die-cast Aluminium
ACCESSIBILITY:	PAS 1899:2022 Compliant when installed as per guidance
CHARGING CONTROL:	In App, RFID, Free vend and Contactless payment (Contactless payment requires charger with payment terminal)



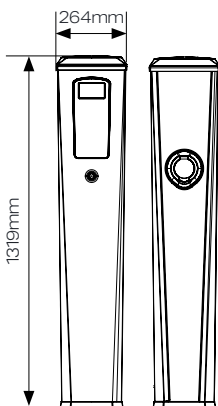
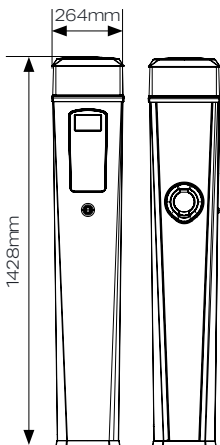

Electrical Specifications

SUPPORTS DAISY CHAIN INSTALL:	Yes, up to 50mm ² cable, up to 130A maximum pass through power
INPUT CABLE MAX SIZE:	50mm ²
MAX INPUT (A):	130A
INTERNAL OVERCURRENT RATING (A):	40A - Three phase, 2x40A - Single Phase
INPUT VOLTAGE:	220-240V (Single Phase) 400-415V (Three Phase)
INPUT FREQUENCY:	50-60hz
PEN FAULT:	Built in
RCD PROTECTION:	Built in 30mA AC Type A & 6mA DC Protection
ELECTRICAL CLASS:	Class 1 with Class 2(II) insulated Housing
ENERGY METER:	Integrated Class B MODBUS MID Meter
TEMPERATURE MONITORING:	Yes
WELD DETECTION:	Built In

ANTI TAMPER DETECTION:	2 Layer Protection built in
OVER VOLTAGE:	Built In

Operating Conditions & Construction

STORAGE:	-30 to 55°C
OPERATING:	-25 to 40°C
RELATIVE HUMIDITY:	5-95%
IP RATING:	IP65
IK RATING:	IK10 Body, IK08 Screen
POWER DISSIPATION:	8W Standby
MOUNTING:	Floor Mounted, 150mm x 150mm fixing centres
MATERIAL:	Stainless steel, Die-cast aluminum and Polycarbonate (PC)
COLOUR:	Black RAL 9005, Grey RAL 9006
DIMENSIONS:	1300 (H) x 263 (W) x 263 (D) 1422 (H) x 265 (W) x 265 (D)

Screen layout

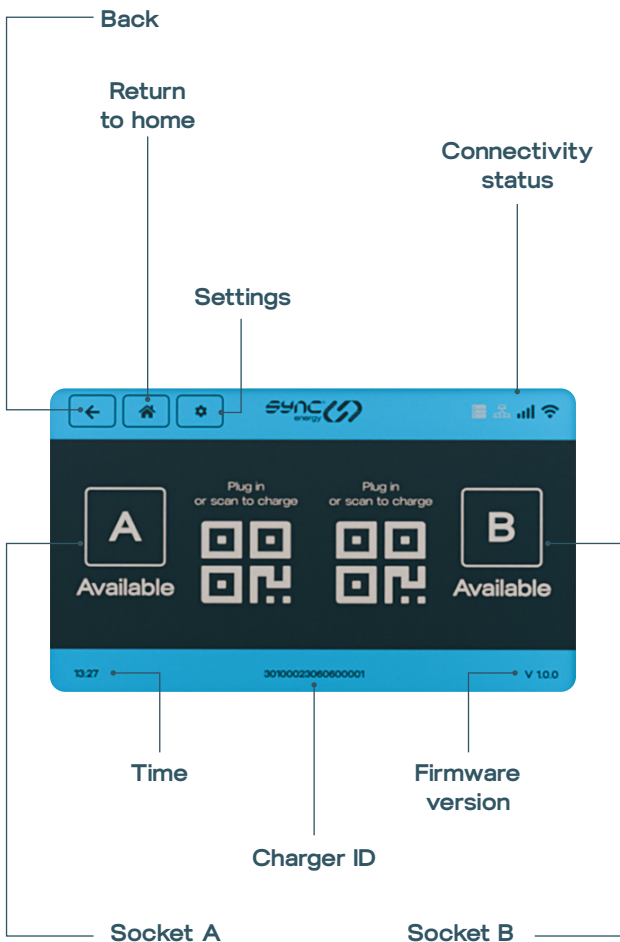

Troubleshooting

For further information, or to refer to our FAQs, please visit our website: www.sync.energy

The status of the EV charger can be identified by referencing the colour shown on the LED indicator:

- **Solid Blue – Standby** – Charger has power and is connected to the network. Or, if in 'plug and charge' mode is not connected to the network, is ready to charge.
- **Flashing BLUE** – Charger is connected but not charging, awaiting confirmation of charge in APP or scheduled start time
- **Solid Dark Green** – Charger is active and Charging
- **Solid Yellow** – Charger is offline from network, check local network is active and Wi-Fi is working on the 2.4Ghz band
- **Flashing Purple** – Indicates the charger has stopped communicating with the Dynamic Load Balancer
- **Flashing Red** – Indicates the charger is in fault mode and has stopped charging for users safety

Potential causes:

- Internal RCD has tripped
- Vehicle fault
- Under or over suitable charging voltage

Remove connection to the vehicle and reset power to the EV charger.

Technical support

Need help with the app?

Contact Monta customer support through the app or via the website [Monta.com](https://www.monta.com)

Need help with the charge-point?

Contact Sync Energy technical support at:

support@sync.energy

or via the website at www.sync.energy

**Sync Energy is a trading name of
Luceco PLC**

Luceco PLC

Stafford Park 1, Telford, TF3 3BD, England

(EU) Luceco SE

C/ Bobinadora 1-5, 08302 Mataro, Spain