



# Home Energy Installation Guide

## 3.6-6KW Hybrid inverter and battery systems



**INSTALLATION IS NOT COMPLETE** until app set up is complete and handed over to end User. End user cannot set up and adjust safety settings of the device. To avoid damage or risk, only use the PV connectors supplied with the inverters.

## Contents

[click to navigate directly to the page](#)

### System Configurations

---

#### Installation

**Option A** - Wall mounted inverter only OR with separate battery stack up to 20kwh

**Option B** - All-in-one consisting of inverter and batteries up to 15kwh

**Option C** - All-in-one and separate battery stack up to 20kwh (35kwh max total)

---

#### Commissioning

---

#### End User App

---

#### Trouble shooting

---

#### Safety information

---

#### System diagrams

---

#### Technical

# System Configurations

Our products are available as an All in One Kit or individual components for those looking to add to an existing system.

This range has been developed for both home users who either have solar panels and want to make the most of their solar energy, or home users who don't have solar yet but want to take advantage of off-peak energy costs by storing energy in our batteries.

## Inverters – Option A installation

A standalone hybrid **inverter** offers the flexibility to add batteries later, while its 150% PV oversupply capability provides greater design freedom and increased capacity to harvest and store solar energy.

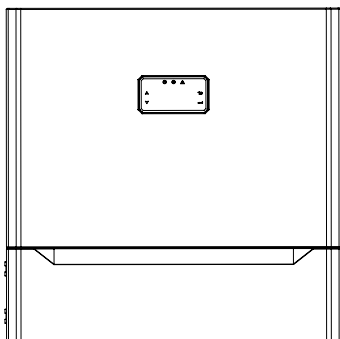

### 3.6kW Inverter

SEFHI36G

Sync Energy Flow Hybrid Inverter 3.6kW

### 6kW Inverter

SEFHI60G

Sync Energy Flow Hybrid Inverter 6kW

## All In One kits – Option B installation

The **All In One kits** offer an energy storage solution; with or without Solar Panels to make the most of off peak energy costs.

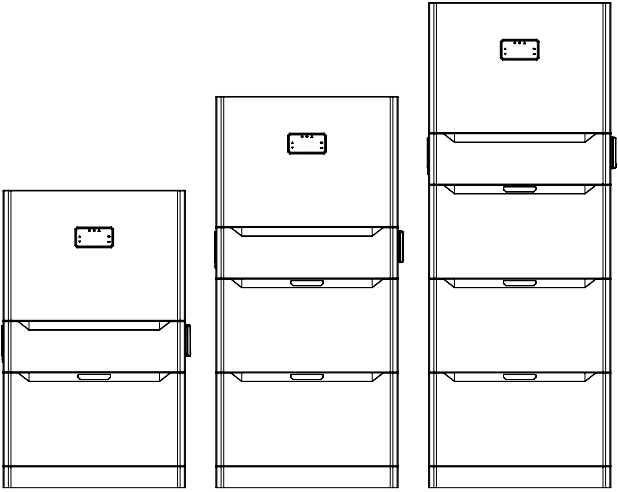

### 3.6kW All In One Kits

SEF1A36G1

Sync Energy Flow All In One 3.6kW + 1 Battery

SEF1A36G2

Sync Energy Flow All In One 3.6kW + 2 Batteries

SEF1A36G3

Sync Energy Flow All In One 3.6kW + 3 Batteries

### 6kW All In One Kits

SEF1A60G1

Sync Energy Flow All In One 6kW + 1 Battery

SEF1A60G2

Sync Energy Flow All In One 6kW + 2 Batteries

SEF1A60G3

Sync Energy Flow All In One 6kW + 3 Batteries

## Batteries – Option C installation

Offering additional **batteries** separately allows for future expansion, enabling you to add up to four extra batteries to your **All In One Kit**.

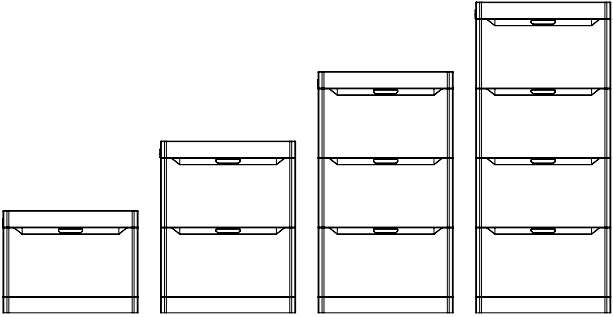

### Battery Stacks

SEFB512G1	Sync Energy Flow 1 Battery 5.1kW
SEFB512G2	Sync Energy Flow 2 Batteries 10.2kW
SEFB512G3	Sync Energy Flow 3 Batteries 15.4kW
SEFB512G4	Sync Energy Flow 4 Batteries 20.4kW

# In Box Contents

## Hybrid inverters – SEFHI36G, SEFHI60G

Hybrid inverter, Wall mounting bracket, 2X cable entry covers, Wall bracket and stack connecting assembly bolts, CT Clamp and Connector, 2X AC power connectors and earth bond ring crimp, 4X PV DC connectors.

## Quick reference wiring information

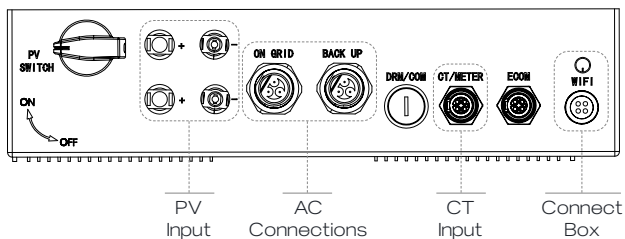

## AC Power connector

AC power connector suitable for 4-6mm<sup>2</sup> cable sizes.

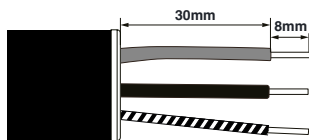

1. Use crimping pliers to press the tubular terminals.

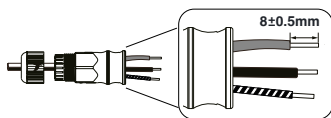

2. Tighten the cable corresponding to the connector with a screwdriver.

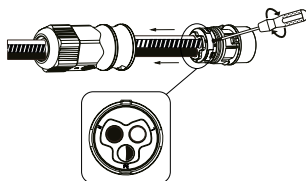

## PV DC Connectors

Suitable for 4mm<sup>2</sup> stranded cable. Ensure only PV DC connectors supplied with the product are used, DO NOT MIX MC4 connector brands.

### 1. PV Connection

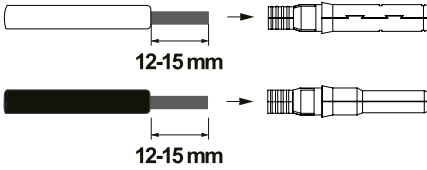

### 2.

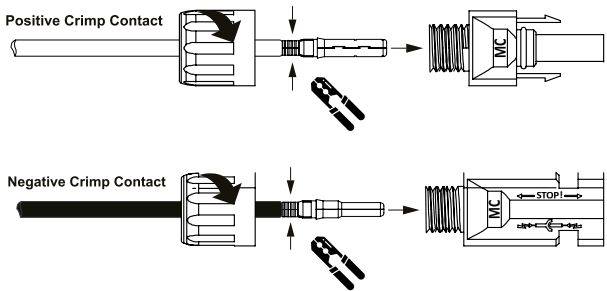

## CT Clamp for Grid monitoring

15mm on outer, 6mm on inner insulation

1 +, 3 - terminals for CT clamp.

2 +, 4 - terminals used for RS485 Modbus meter

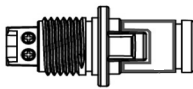

AC isolator

Battery isolator

Battery overcurrent protective device

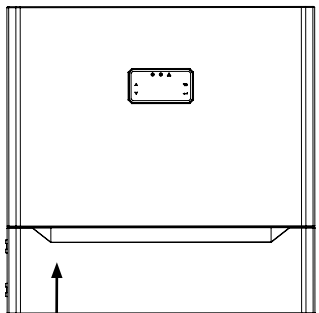

DC solar isolator

## Installation options

There are 3 options to installation

- **Option A** - Wall mounted Inverter or additionally with separate floor stack up to 20kwh
- **Option B** - One stack - consisting of inverter and up to 15kwh of batteries
- **Option C** - Two stacks - consisting of inverter and batteries up to 15kwh, with a separate battery stack up to 20kwh

**Option A** - Wall mounted Inverter with separate floor stack up to 20kwh

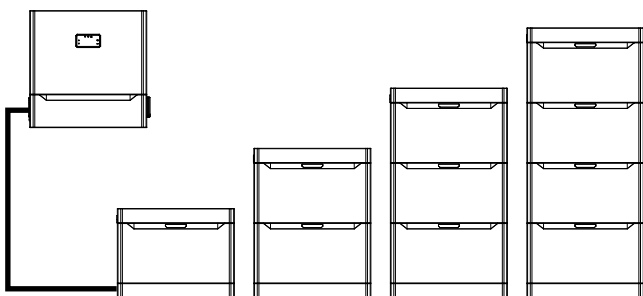

**Option B** - One stack - consisting of inverter and up to 15kwh of batteries

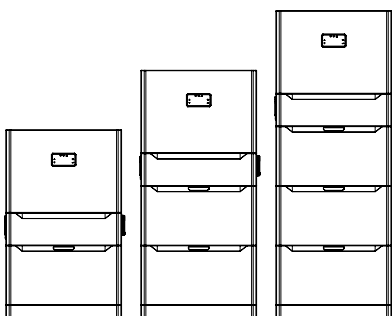

**Option C** - Two stacks – consisting of inverter and batteries up to 15kwh, with a separate battery stack up to 20kwh

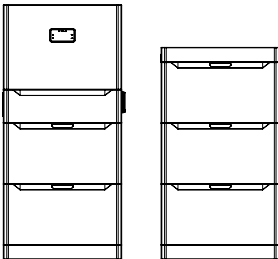
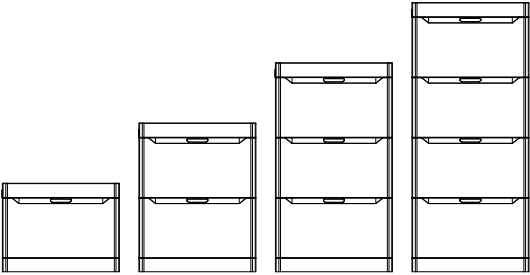
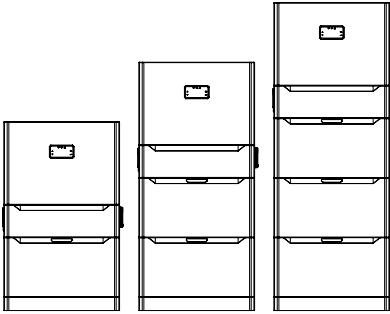

Example of finished installed option C

**Note** - All measurements in mm.

Power into the system can either be brought in from the sides or through the back of the inverter.

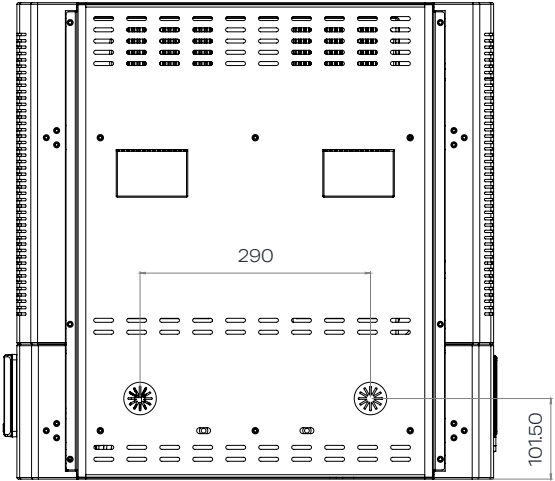

All in one system

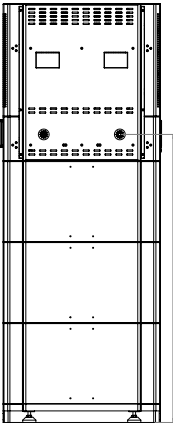

Inverter  
+ 3 Batteries

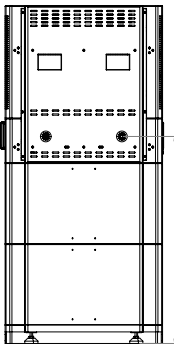

Inverter  
+ 2 Batteries

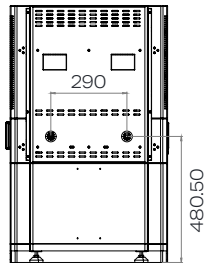

Inverter  
+ 1 Battery

**Note** - Systems with a second stack with 1 or 2 Batteries: the connecting cable must come from the bottom of the HEMS system (stack 1) into the top of the second stack (stack 2).

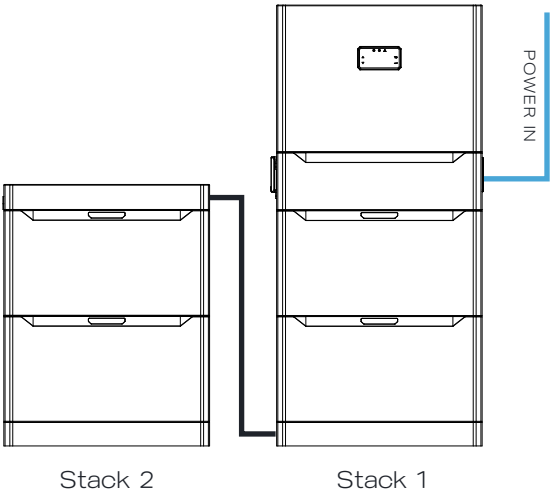
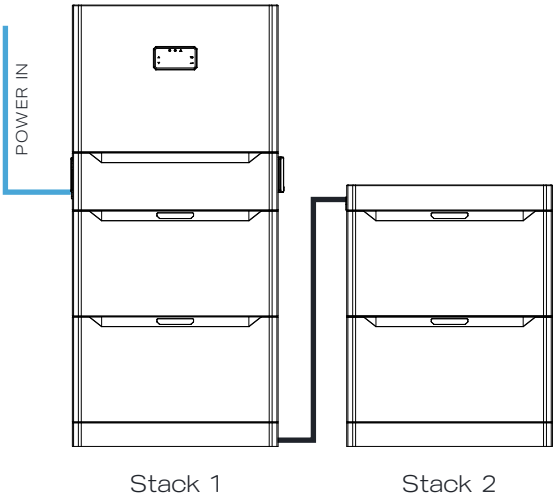

**Note** - Systems with a second stack with 3 or 4 Batteries: the connecting cable must come from the bottom of the HEMS system (stack 1) and into the bottom of the 2nd stack (stack 2).

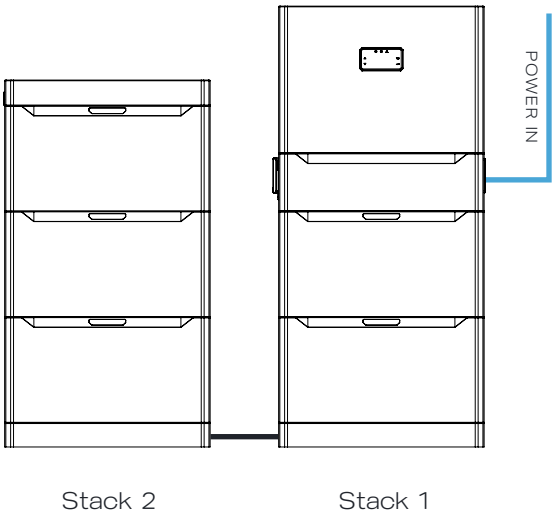
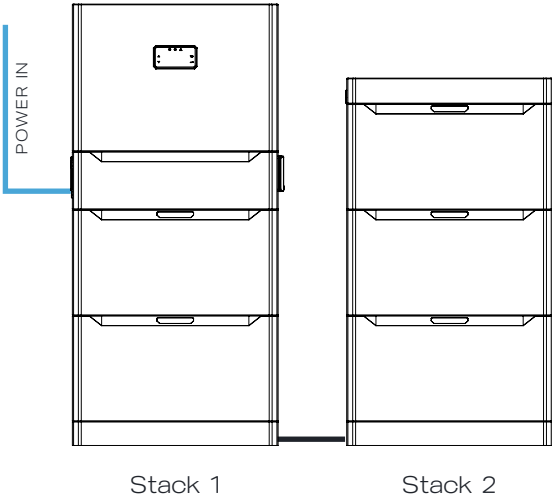

## Install steps

**Option A** - Wall mounted Inverter with separate floor stack up to 20kwh.

**Note** - Before installation make sure wall is suitable to support weight of 43kg inverter.

1. Using included drill template mark and drill holes labelled INV- add wall plugs if needed.
2. Screw inverter bracket to wall ensuring bracket sits flush and bracket is secured.
3. Lower inverter onto bracket, inverter should sit inside 2x bracket hooks. Open inverter door and insert 2x locking screws this will fix the inverter to the bracket.
4. Place battery base on floor, using a spirit level loosen and tighten 4x feet until base is flat.

**Note** - Make sure battery stack is installed within 2 meters of inverter. if installation consists of one or two batteries ignore this step. If it consists of three or four batteries, then assemble link cable into base. Add the first battery onto battery base making sure the cable connector is inserted fully.

5. Attach battery bracket to one of the batteries (this battery will need to be added last).
6. Stack remaining batteries (maximum of 4 for this configuration). However, do not stack the final battery. Instead, place the drill template on the second-to-last battery, aligning it with the two pegs. Drill the holes marked **BATTERY**, and insert wall plugs if necessary.
7. Add remaining battery to stack and screw through the bracket on the battery, this now connects the stack to the wall.

8. Connect both inverter to battery stack (if this has already been done this step can be skipped) The connector for the battery stack is on the top battery on the right side. After connecting inverter stack to battery stack the battery cap can be added covering the cable between both stacks.
  9. There is a cut out on both the left and right side of the inverter, push Wi-Fi dongle cable into the side where the dongle will be installed and push dongle into cut out.
- Using included drill template mark and drill holes labelled **INV** - add wall plugs if needed

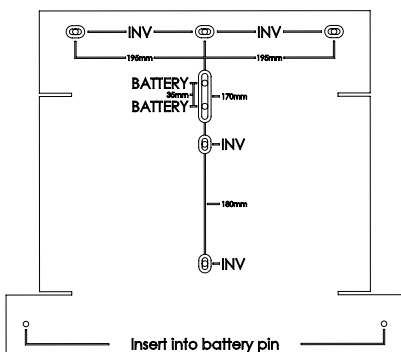

- Screw inverter bracket to wall ensuring bracket sits flush and bracket is secured

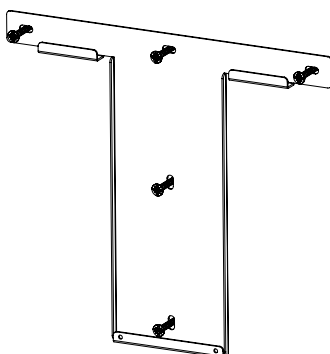

- Lower inverter onto bracket, inverter should sit inside 2x bracket hooks

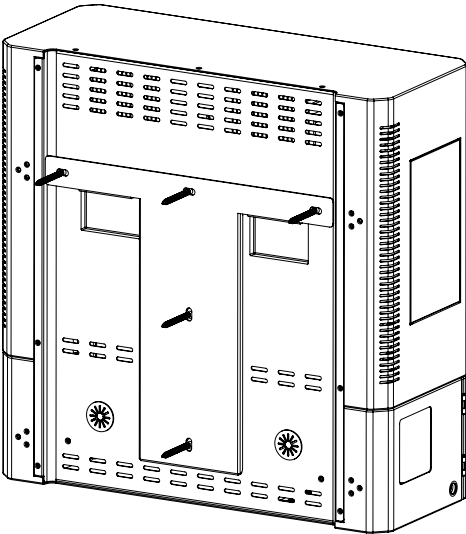
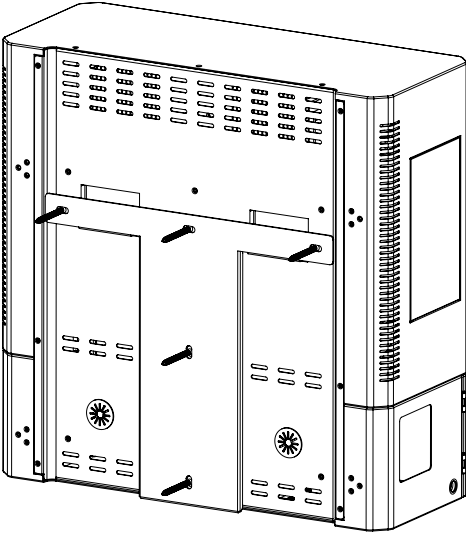

- Open inverter door and insert 2x locking screws this will fix the inverter to the bracket

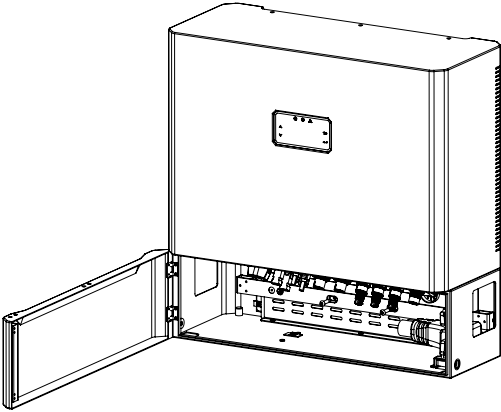

- Place battery base on floor, using a spirit level loosen and tighten 4x feet until base is flat

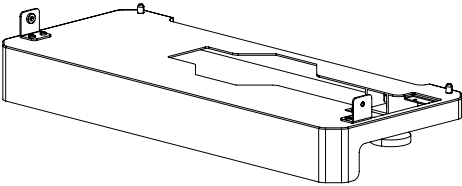

**Note** - Make sure battery stack is installed within 0.5 meters of inverter. If installation consists of one or two batteries ignore this step. If it consists of three or four batteries, then assemble link cable into base. Add the first battery onto battery base making sure the cable connector is inserted fully.

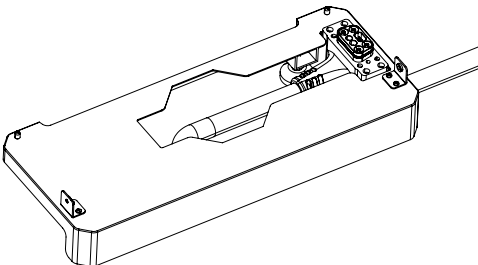

- Attach battery bracket to one of the batteries (this battery will need to be added last)

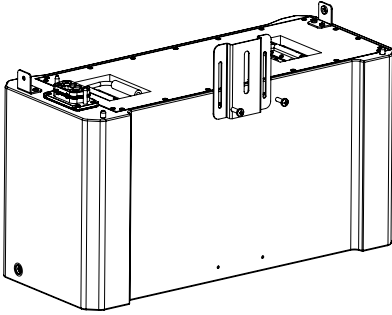

- Stack batteries (maximum of 4 for this configuration) however do not stack the last battery, on the 2nd to last battery add the drill template, this needs to be inserted into the 2 pegs, drill holes marked **BATTERY** and insert wall plugs if needed

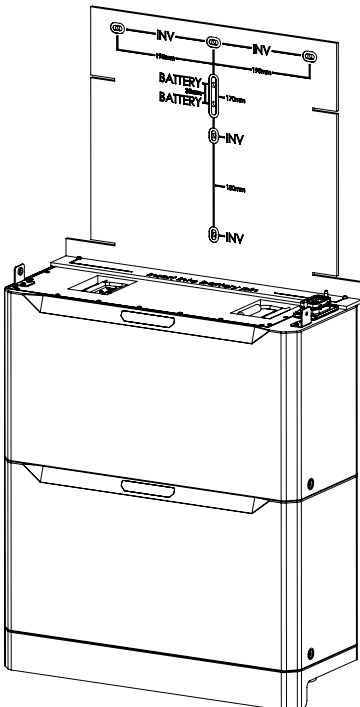

- Add remaining battery to stack and screw through the bracket on the battery, this now connects the stack to the wall

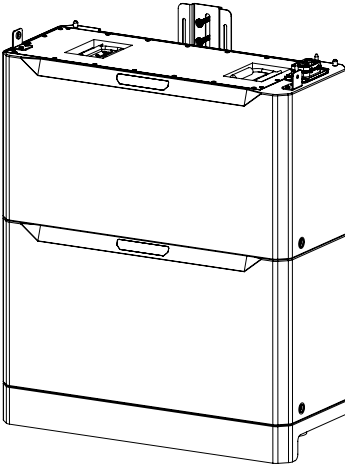

- Connect both wall mounted inverter to battery stack stack (this may need to be purchased separately)

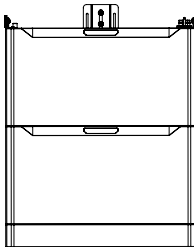
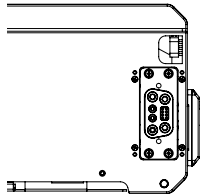
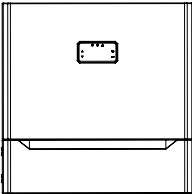

- After connecting inverter to battery, the battery cap can be added to the battery stack covering the cabling

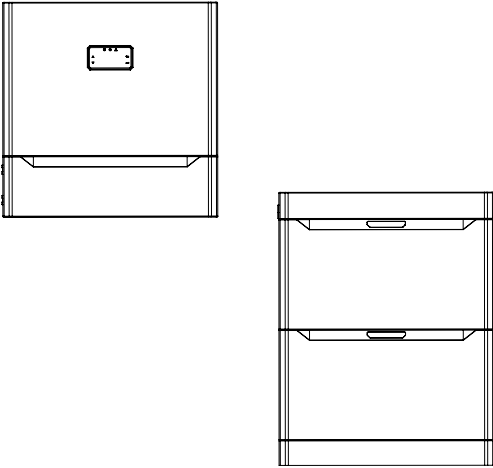

- There is a cut out on both the left and right side of the inverter, push Wi-Fi dongle cable into the side where the dongle will be installed and push dongle into cut out – Note WIFI dongle can go either side

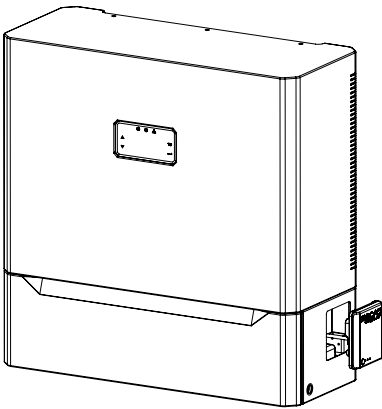

**Option B** - One stack – consisting of inverter and up to 15kwh of batteries.

1. Place battery base on floor, using a spirit level loosen and tighten 4x feet until base is flat.

**Note** - If installation consists of multiply stacks or the inverter is mounted separately then add link cable now (if cable is included, we recommend doing this to future proof the system for additional batteries).

2. Stack batteries (maximum of 3 for a 1 stack configuration) on the 2nd to last battery add the drill template, this needs to be inserted into the 2 pegs, drill 5x holes marked **INV** add wall plugs if needed.
3. Screw inverter bracket to wall ensuring bracket sits flush and bracket is secured.
4. Attach inverter to bracket by stacking it on top battery, inverter should sit inside 2x bracket hooks.

Open inverter door and insert 2x locking screws this will fix the inverter to the bracket.

5. There is a cut out on both the left and right side of the inverter, push Wi-Fi dongle cable into the side where the dongle will be installed and push dongle into cut out.

- Place battery base on floor, using a spirit level loosen and tighten 4x feet until base is flat

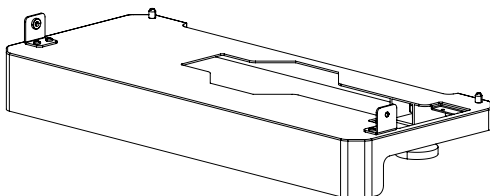

**Note** - If installation consists of multiple stacks or the inverter is mounted separately then add link cable now (if cable is included, we recommend doing this to future proof the system for additional batteries). Ensure the second stack is placed within 0.5 meters of the first stack.

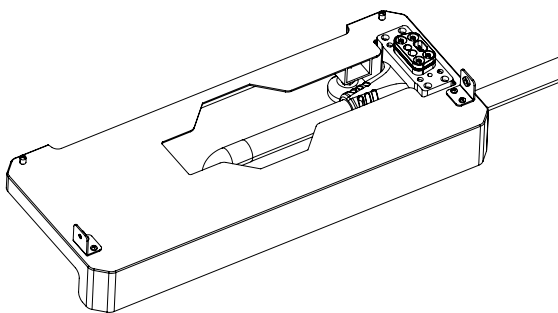

- Stack batteries (maximum of 3 for a 1 stack configuration) on the 2nd to last battery add the drill template, this needs to be inserted into the 2 pegs, drill 5x holes marked **INV** add wall plugs if needed

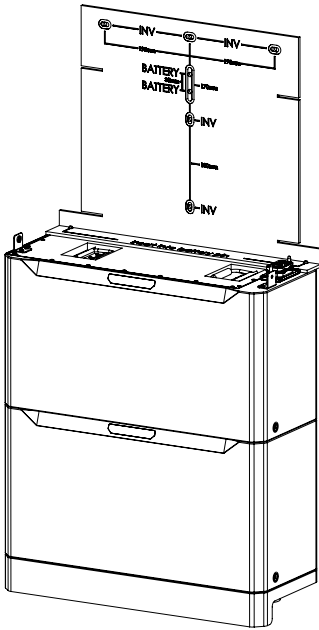

- Screw inverter bracket to wall ensuring bracket sits flush and bracket is secured

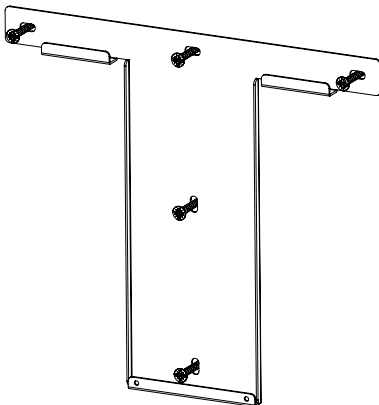

- Attach inverter to bracket by stacking it on top battery, inverter should sit inside 2x bracket hooks, open door and fix inverter to bracket using 2x screws

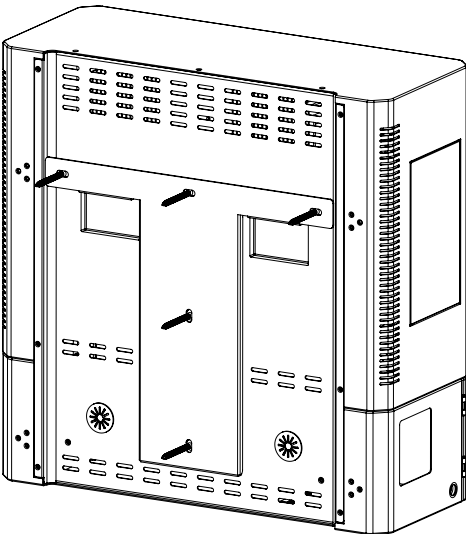
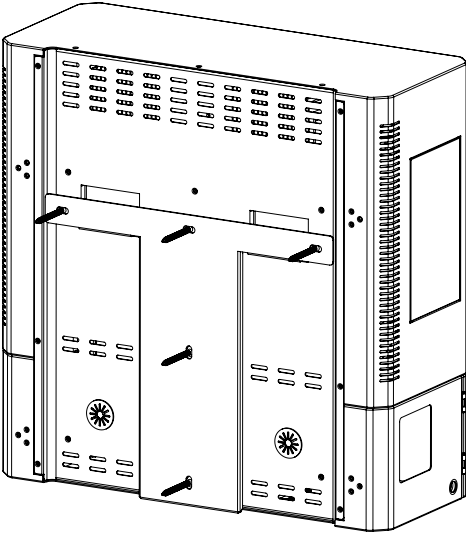

**Note - For a two stack system ignore this step**

- There is a cut out on both the left and right side of the inverter, push Wi-Fi dongle cable into the side where the dongle will be installed and push dongle into cut out

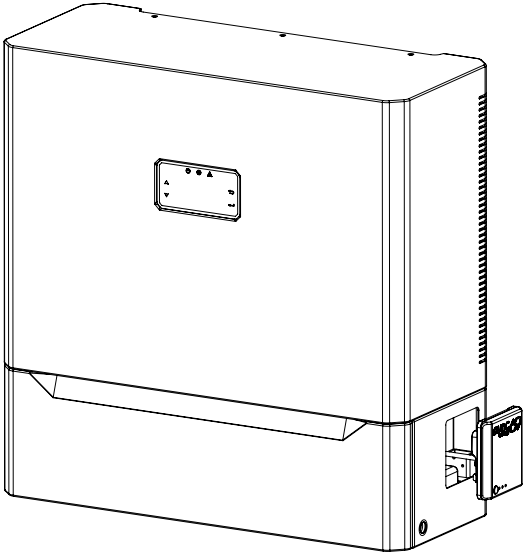

- Option 2 finished install example – 1 inverter with 2x 5kwh battery with dongle installed on the right side

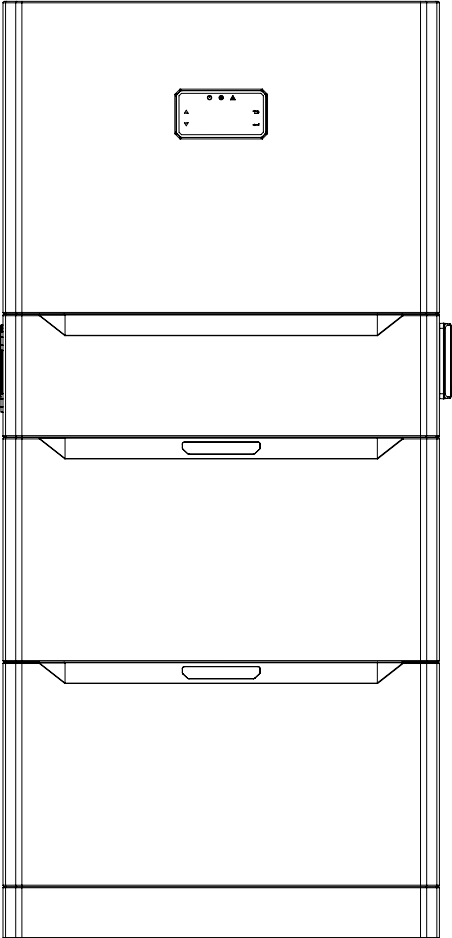

**Option C** - Two stacks – consisting of inverter and batteries up to 15kwh, with a separate battery stack up to 20kwh.

**Note** – Make sure to complete option B install steps first before working through option C – make sure link cable is already attached to the first stack. Make sure battery stack is installed within 2 meters of inverter.

1. Place battery base on floor, using a spirit level loosen and tighten 4x feet until base is flat, using the other end of the cable, fix connector into base this must be done for second stacks of three or four batteries, if second stack consists of one or two batteries than the cable must go into the top of the second stack and therefore the connection between stacks can be done later on.

Add the first battery onto battery base making sure the cable connector is inserted fully.

2. Attach battery bracket to one of the batteries (this battery will need to be added last).
3. Stack remaining batteries (maximum of 4 for this configuration) however do not stack the last battery, on the 2nd to last battery add the drill template, this needs to be inserted into the 2 pegs, drill holes marked BATTERY and insert wall plugs if needed.
4. Add remaining battery to stack and screw through the bracket on the battery, this now connects the stack to the wall.
5. Connect both inverter stack to battery stack (if this has already been done this step can be skipped) The connector for the battery stack is on the top battery on the right side.

6. After connecting inverter stack to battery stack the battery cap can be added covering the cable between both stacks.
7. There is a cut out on both the left and right side of the inverter, push Wi-Fi dongle cable into the side where the dongle will be installed and push dongle into cut out.

**Note:** WIFI dongle can go either side.

- Make sure battery stack is installed within 2 meters of inverter, add the first battery onto battery base making sure the cable connector is inserted fully

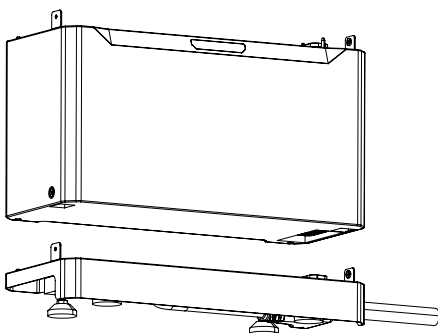

- Attach battery bracket to one of the batteries (this battery will need to be added last)

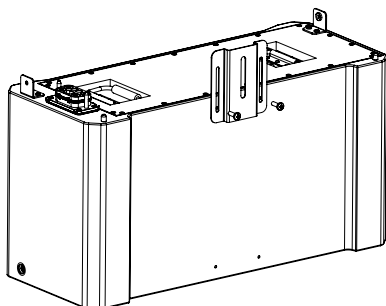

- Stack batteries (maximum of 4 for this configuration) however do not stack the last battery, on the 2nd to last battery add the drill template, this needs to be inserted into the 2 pegs, drill holes marked **BATTERY** and insert wall plugs if needed

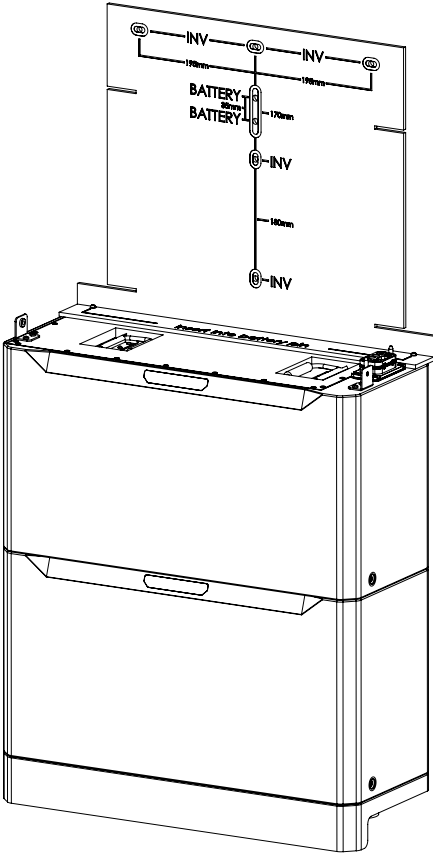

- Add remaining battery to stack and screw through the bracket on the battery, this now connects the stack to the wall

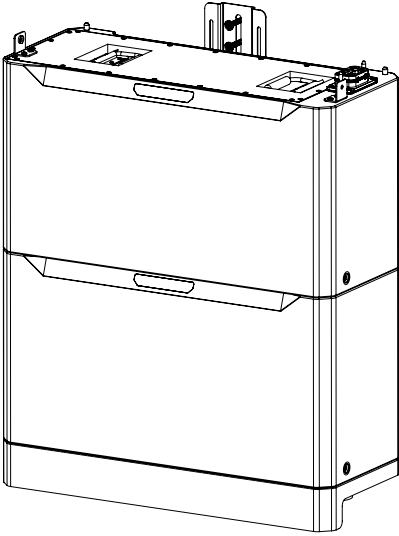

- Connect both inverter stack to battery stack (this may need to be purchased separately)  
The connector for the inverter stack will be underneath the first battery on the right side, the connector to the battery stack is on the last top battery on the right side

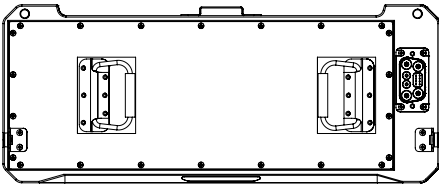
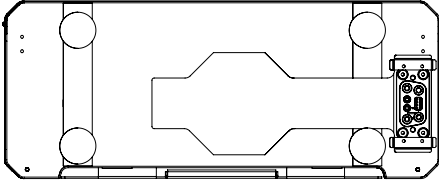

- After connecting inverter stack to battery stack the battery cap can be added covering the cable between both stacks

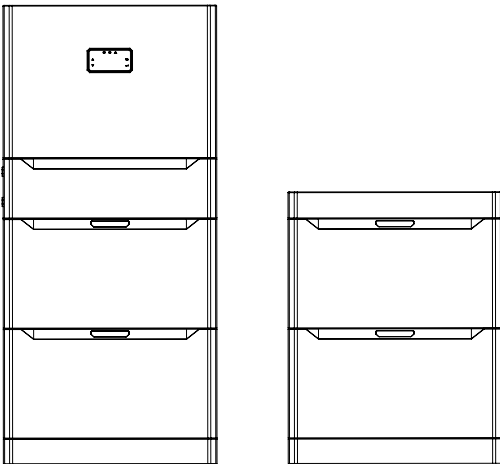

- There is a cut out on both the left and right side of the inverter, push Wi-Fi dongle cable into the side where the dongle will be installed and push dongle into cut out - **Note** - WIFI dongle can go either side

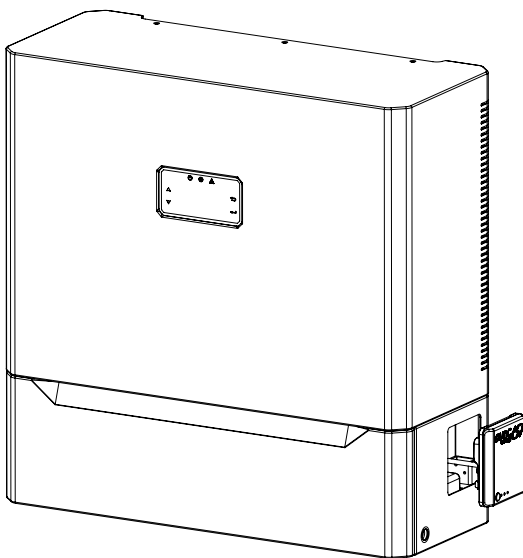

# Installer commissioning and set up

INSTALLER APP – [Download the 'Sync Energy' app by clicking this link](#)

**NOTE** – To set up Flow systems, you will need have a Approval code for your account.

Also available from the Installer Portal on the [sync.energy website](#), or using the QR code opposite.



**Intuitive Interface:** The revamped interface is designed with the installer in mind. Everything you need is available through a new side-menu.

**Effortless Setup:** seamlessly configure your EV Chargers and Balancer devices with just a few taps. Get up and running in no time.

**Account Management:** Create and manage your account effortlessly. Keep a history of all your installed Chargers.

On Powering up the device, the Network status light should be flashing quickly, if not, Press and hold the button on the smart network dongle for 10 seconds to put it in set up – pairing mode.

For Wi-Fi connection, we recommend that the router is set to only 2.4GHz band to reduce the risk of possible conflicts. Once setup the router can be restored to both 2.4Ghz & 5Ghz bands.

1

From the menu, Select "Add a Device" and on the next page, Select "inverter"

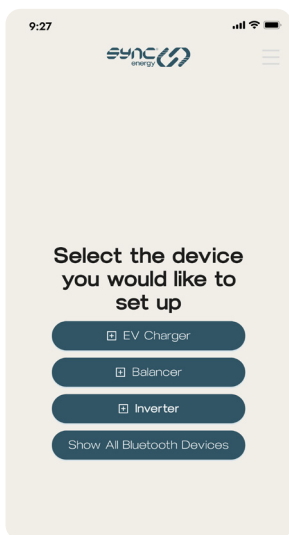
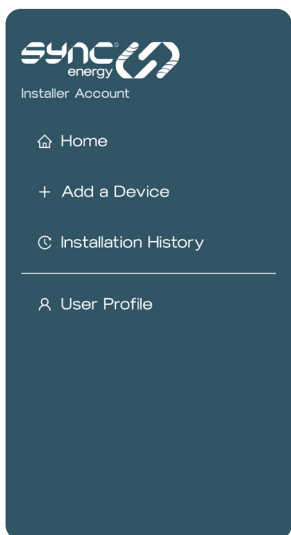

2

Scan for the device. If it is not showing, press-and-hold the button on the Smart Network Dongle for 10 seconds and try again.

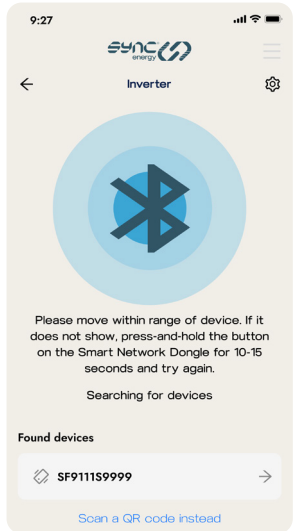

3

When prompted, type the set-up pin found on the sticker on the paperwork, and on the back of the Smart Network Dongle.

4

Select the Wi-Fi network and enter the Wi-Fi password. Ensure that there is a 2.4 GHz Wi-Fi network.



The System will run through initial configuration, registration and network checks.

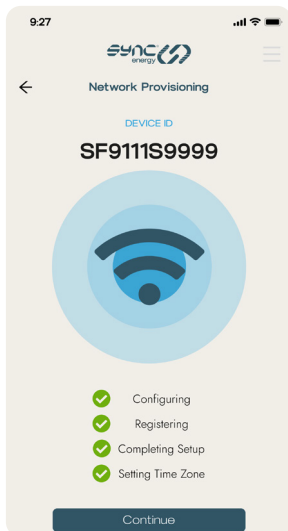

5

Follow on-screen steps to update firmware (if applicable).



6

For first-time installation, we recommend using the setup wizard.

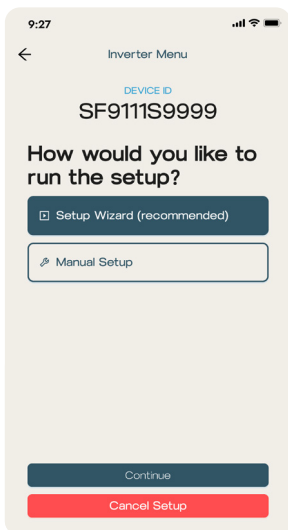

7

**Safety Settings** – Select the electrical setting, This will trigger the inverter to restart.

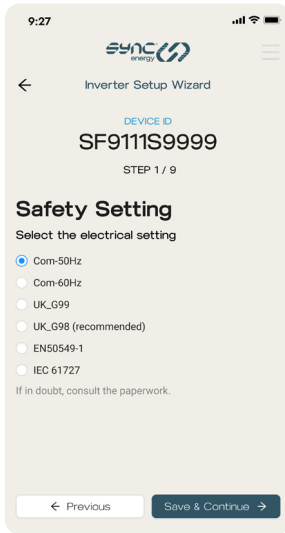

9:27 SYNC energy

Inverter Setup Wizard

DEVICE ID  
SF9111S9999

STEP 1 / 9

### Safety Setting

Select the electrical setting

- Com-50Hz
- Com-60Hz
- UK\_G99
- UK\_G98 (recommended)
- EN50549-1
- IEC 61727

If in doubt, consult the paperwork.

← Previous Save & Continue →

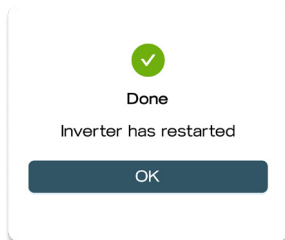

✓

**Done**

Inverter has restarted

OK

8

**Apply Default Settings** – this will set up to the most typical settings and avoid additional steps for most installation, values set are shown as set.

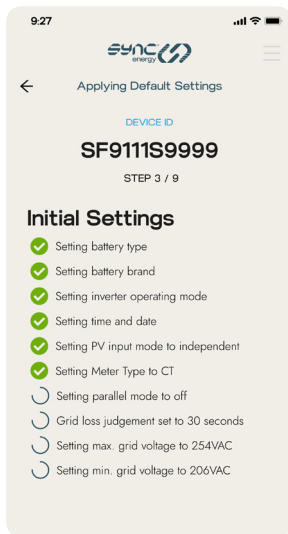
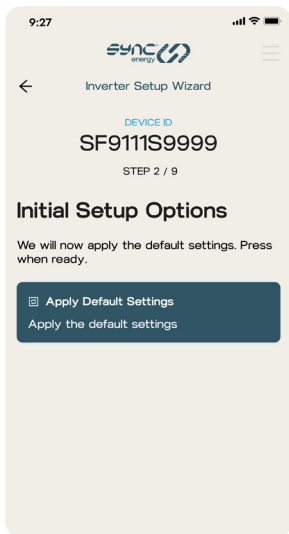

9

**Solar and battery settings** – select the type of solar, and number of batteries connected to the system.

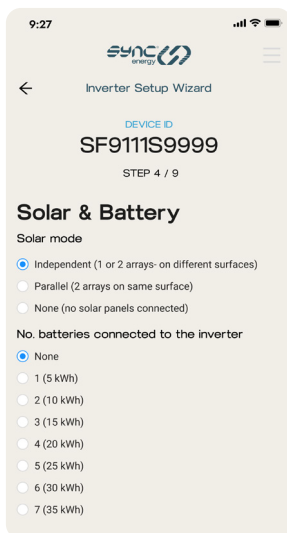

10

**Limits and metering** – Check the Grid voltage and current match with local measurements. Then enter the import and export power limits in **KW**

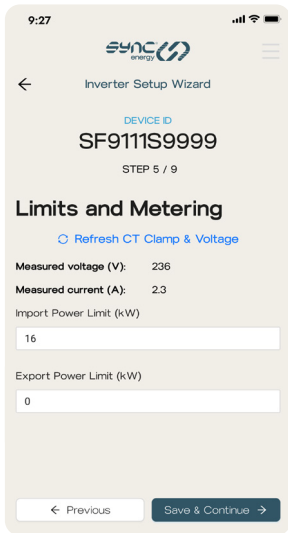

11

**Battery Levels** – Set the minimum and maximum battery charge level. We recommend setting the minimum at 10% and the maximum at 100%.

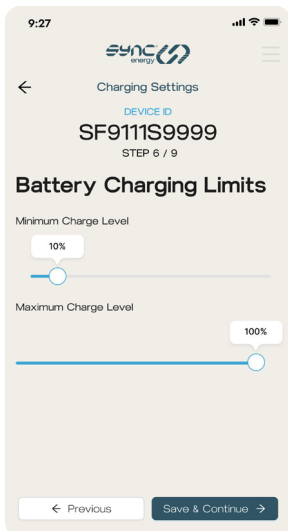

## System Information

- Check the System test page for inputs. If PV is not showing, check to see if the physical isolator on the product has been switched to "On" position.
- Start the test to check the system is operating as it should. This test can take up to 5 minutes.

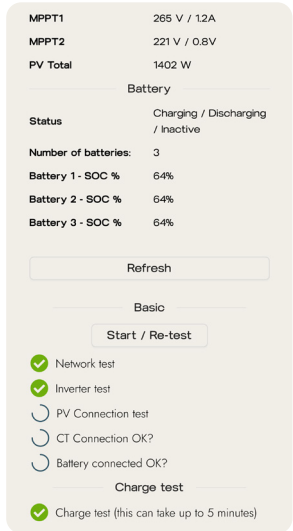
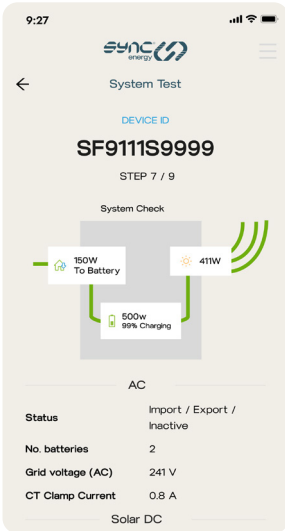

**Important** – Ensure the home user has created an account and it is the Home User account type. If they have created an installer account, they can convert it into a home user account in the General Settings menu, under "Advanced".

When the home user is ready to accept the device, scan their QR code, and their app will prompt them to accept it.

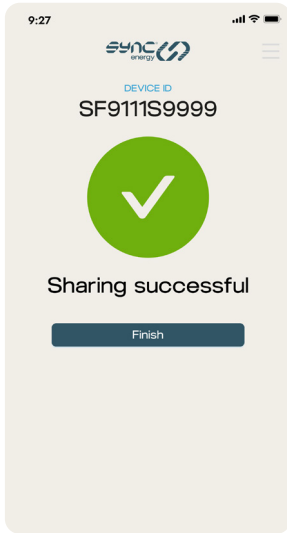
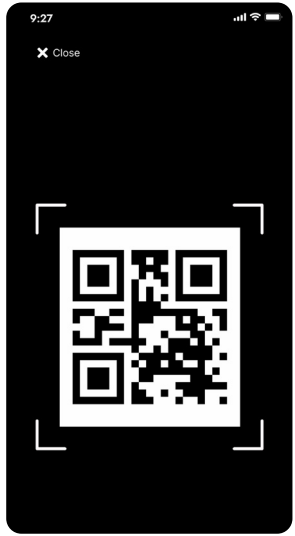
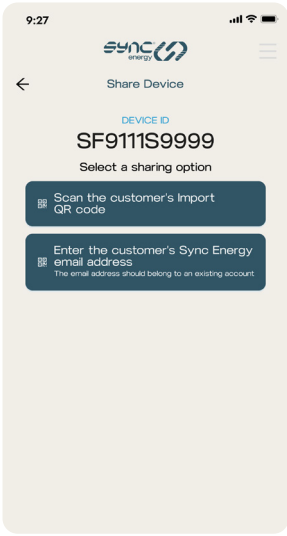

Alternatively, if you are not at site, you can enter their email address.

9:27

**sync**  
energy

Share Device

DEVICE ID  
**SF9111S9999**

Please enter the end-user's email address.  
The e-mail address should belong to an existing Sync Energy account

Email address

Next

9:27

**sync**  
energy

DEVICE ID  
**SF9111S9999**



Sharing successful

Finish

# Safety Information

Read all the safety information and instructions, Failure to follow the stated instructions and operate the Flow home energy system according to instructions may cause injury or damage to the system.

There are no user serviceable components within the battery or inverter system, and should not be opened or repair made except for trained and qualified Sync Energy service engineers.

**When using SWA cable, an additional connection must be made, either at the isolator or other connection. Inverter connection is only suitable for Flex/rubber and non SWA cables.**

**Warning:** The supplied Sync Energy charger is manufactured to be safe without risk provide they are installed correctly, used, and maintained in accordance with the manufacturers recommendations and installed by a competent electrical installer in accordance with national and local regulations and legislation applicable at the time of installation, e.g. BS7671:2018 amendment 3.

The supply should run from a dedicated circuit breaker. We recommend the use of a Type B curve circuit breakers. Recommended circuit breaker ratings:

for non back up - 3.6KW – 16A, on a 6KW -32A

with backup/pass through power -3.6KW – 20A, 6KW-40A

RCD protective devices are required when:

1. For cables without earthed metallic covering installed in walls or partitions at a depth of less than 50mm and also within walls and partitions with metal parts, and not protected by steel conduit or similar then RCD protection is required.

2. If the cable is clipped directly to the surface of a wall and does not pass through a wall or partition to the device then a standard B type MCB may be installed into the Consumer unit, however RCD protection may be required for other reasons such as if it forms part of a TT system and the earth fault loop impedance values cannot be met. This will be in compliance with the current BS7671

Amendment 2 Wiring Regulations. To conform with BS 7671, on occasions a two pole MCB/ RCD or other means of isolation may be required. Important note: A DC Leakage fault in the system may "blind" a type "AC" RCD and render it ineffective, never feed any Energy system From an upstream Type "AC" RCD.

Isolation and switching for safety and maintenance To ensure the energy system can be "turned off" to enhance security and enable maintenance activities, a two pole isolator (or DP RCD or RCBO) suitably rated must be installed within the customer's property. An isolator switch is a mandatory requirement for "new builds", but optional for existing dwellings (at customer's request), the switch should be mounted between 500mm and 1500mm above finished floor level to comply with regulations. The switch should be rated at 20 or 40 Amps. All installations must comply to BS7671: 2018.

Final Electrical testing To meet the BS7671:2018 (18th edition) requirements for testing of an electrical installation, the following tests and checks shall be performed by a competent electrical installer before during and after a Sync Energy system is installed:

- A visual inspection of the installation including the existing electrical installation
- Verification of the characteristics of the electrical supply at the origin of the installation to confirm the supply is suitable for the additional load

- A test to confirm the continuity of the circuit protective conductors
- A test to confirm the integrity of the circuit insulation resistance
- A test to confirm the polarity of the installation is correct

Where applicable a test to confirm the earth electrode resistance is within acceptable tolerances (or)

- An earth loop impedance test
- A test of the mechanical operation of residual current devices (RCD's)
- A test to confirm the operation of residual current devices (RCD's) is within stipulated time scales (at the rated current and at five times the rated current operating current)
- A test or calculated measurement of the prospective fault current
- An electrical installation certificate must be completed

## Grid Compliance

When installed and set up as instructed, the Flow System operates under the following Grid compliance modes:

G98/G99/G100

These require the Grid monitoring CT Clamp fitted and connected to the system as supplied. G100 is limited by the Import limit settings, and G98/ G99 are set with the Safety system and Export restriction settings.

# Grid Compliance

When installed and set up as instructed, the Flow System operates under the following Grid compliance modes:

G98/G99/G100

These require the Grid monitoring CT Clamp fitted and connected to the system as supplied. G100 is limited by the Import limit settings, and G98/ G99 are set with the Safety system and Export restriction settings.

## Safety Warning: High Voltage Hazards in the PV

The PV array, battery, and associated components pose a serious risk of electric shock due to high voltages. When exposed to sunlight, the PV array generates dangerous DC voltage, which remains present in the DC conductors and live components of the inverter. Contact with these elements can result in lethal electric shocks.

Additionally, disconnecting the DC connectors under load may trigger an electric arc, potentially causing electric shock and burns. To ensure safety, a properly calibrated voltage tester must be used before any installation or maintenance work is performed.

### Precautionary Measures:

- The inverter may retain hazardous voltage even after being disconnected from both the DC and AC sides. Ensure discharge time is left after isolation before service or disconnections
- Avoid touching uninsulated cable ends

- Do not come into contact with DC conductors
- Do not attempt to open the inverter or battery
- Only qualified personnel with the appropriate expertise should install and commission the system
- Before carrying out any work on the inverter or battery pack, disconnect the inverter from all voltage sources following the instructions in the provided documentation

Safety should always come first—proper handling and adherence to these guidelines can prevent life-threatening injuries.

### **Battery Safety Information**

This product is a Lithium Iron Phosphate Battery, certified under the UN Recommendations on Transport of Dangerous Goods (Manual of Tests and Criteria, Part III, subsection 38.3). The battery cells are securely housed within a hermetically sealed metal casing, designed to withstand the temperatures and pressures encountered during normal operation. As a result, there is no risk of ignition, explosion, or hazardous material leakage under standard conditions.

However, if the battery is exposed to fire, mechanical shock, or electrical stress due to misuse, the gas release vent may activate, potentially breaching the cell casing. In extreme cases, hazardous substances could be released. Additionally, intense heating from surrounding fire may lead to the emission of acidic or harmful fumes.

To ensure safe handling, always follow the recommended guidelines and avoid exposing the battery to conditions that could compromise its integrity.

## **Disposal Guidelines**

In compliance with European Directive 2012/19/EU on waste electrical and electronic equipment, all used electrical devices must be collected separately and recycled responsibly. Proper disposal helps minimize environmental impact and supports sustainable recycling practices.

To ensure correct disposal:

- Return your used device to us or consult authorized local collection and disposal services.
- Follow national regulations regarding electronic waste management.

Failure to adhere to this directive may contribute to environmental harm. Responsible recycling ensures a safer, greener future.

# Guarantee

Guarantee Sync Energy products are guaranteed against faulty materials and workmanship for a period of 10 years from date of delivery: products will be repaired or (at Sync Energy's discretion) replacements will be supplied or (at Sync Energy's discretion) a credit note will be issued. This guarantee is subject to Sync Energy's conditions of sale and in particular to the following conditions being met:

1. Notification of any defect is given to Sync Energy as soon as reasonably practicable after becoming apparent, and the products then returned to Sync Energy
2. The products have only been operated under normal operating conditions and have only been subject to normal use
3. No work (other than normal and proper maintenance) has been carried out to the products without Sync Energy's prior written consent
4. The products have been assembled, or incorporated into other goods, by a qualified and recognised electrician and only in accordance with any instructions issued by Sync Energy
5. The defect has not arisen from an item manufactured or supplied by a person other than Sync Energy
6. Batteries have a 10 Years or 6000 cycle life warranty, when operated within the manufacturers depth of discharge limit (90%)

# 3.6kW ALL IN ONE

## General Specifications

Product Code	SEF1A36G1	SEF1A36G2	SEF1A36G3
Product	Sync Energy Flow All In One 3.6kW + 1 Battery	Sync Energy Flow All In One 3.6kW + 2 Batteries	Sync Energy Flow All In One 3.6kW + 3 Batteries
Number of Battery Modules	1	2	3
Battery Capacity (kW)	5.12	10.24	15.4
Inverter Power (kW)	3.6	3.6	3.6
Weight (kg)	99.6	150.7	201.8
Dimensions (with Floor Stand) (H x W x D mm)	979 x 621 x 245	1288 x 621 x 245	1597 x 621 x 245
Mounting Installation	Wall Mounting (Inverter Only) Or Floor Stand	Wall Mounting (Inverter Only) Or Floor Stand	Wall Mounting (Inverter Only) Or Floor Stand

## Battery Storage

Product Code	SEF1A36G1	SEF1A36G2	SEF1A36G3
Nominal Voltage (V)	51.2		
Operating Temperature (Charge) (C°)	Integrated heating below 5		
Operating Temperature (Discharge) (C°)	-20 to +60		
Ambient Temperature (C°)	-15 to +55		
Relative Humidity (%)	65±20		
Charging Current (kW)	3.6		
Recommended Charging Current (A)	50		
Maximum Charge Current (A)	100		
Battery Voltage Range (V)	44.8 - 56.2		
Max. Charge/ Discharge Power (kW)	3.6		
Max. Charge/ Discharge Current (A)	80		
Battery Type	LiFePo4 (Lithium Ferrous Phosphate)		

## PV Input

Product Code	SEF1A36G1	SEF1A36G2	SEF1A36G3
Max. Input Power (kW)	5.4 (150%)		
Max. PV Voltage (V)	550		
MPPT Range (V)	80-500		
Full MPPT Range (V)	110-500		
Normal Voltage (V)	360		
Startup Voltage (V)	100		
Max. Input Current (A)	18.5 x 2		
Max. Short Current (A)	26 x 2		
No. of MPP Tracker / No. of PV strings	2 / 2 Independent Strings		

## Efficiency

Product Code	SEF1A36G1	SEF1A36G2	SEF1A36G3
App	Powered By Sync Energy		
Warranty	10 Years / 6000 Cycles		
Display & Communication Interfaces	LCD, LED, RS485, CAN, Wi-Fi Ethernet		
Certification & Approvals	G98/G99 EN62109-1, EN62109-2		
EMC	EN61000-6-2, EN61000-6-3		

## AC information

Product Code	SEF1A36G1	SEF1A36G2	SEF1A36G3
Max Continuous Current (A)		17	
Max Continuous Power (kVA)		3.6	
Max Peak Current (A) (10min)		24.6/23.5	
Max Peak Power (kVA) (10min)		5.4	
Nominal AC Voltage L-N (V)		220/230	
Nominal AC Frequency (Hz)		50/60	
Switching Time (ms)		Seamless	
Voltage THD (%)		< 3	

## Efficiency

Product Code	SEF1A36G1	SEF1A36G2	SEF1A36G3
CEC Efficiency (%)		97	
Max. Efficiency (%)		97.6	
PV to Bat. Efficiency (%)		98.1	
Bat. Between AC Efficiency (%)		96.8	

## Protection & Safety

Product Code	SEF1A36G1	SEF1A36G2	SEF1A36G3
PV Reverse Polarity Protection		YES	
Over Current/ Voltage Protection		YES	
Anti-Islanding Protection		YES	
AC Short Circuit Protection		YES	
Residual Current Detection		YES	
Ground Fault Monitoring		YES	
Insulation Resistance Detection		YES	
Enclosure Protect Level		IP65	
AC/DC Surge protection	Type II Intergrated Protection		
Topology	Transformerless		
Cooling Method	Intelligent Fan		
Operating Altitude (m)	< 2000		
Noise Emission (dB)	< 25		
Standby Consumption (W)	< 10		
Fire Suppression Module	Intergrated In Each Battery Module		

# 6kW ALL IN ONE

## General Specifications

Product Code	SEF1A60G1	SEF1A60G2	SEF1A60G3
Product	Sync Energy Flow All In One 6kW + 1 Battery	Sync Energy Flow All In One 6kW + 2 Batteries	Sync Energy Flow All In One 6kW + 3 Batteries
Number of Battery Modules	1	2	3
Battery Capacity (kW)	5.12	10.24	15.4
Inverter Power (kW)	6	6	6
Weight (kg)	99.6	150.7	201.8
Dimensions (with Floor Stand) (H x W x D mm)	979 x 621 x 245	1288 x 621 x 245	1597 x 621 x 245
Mounting Installation	Wall Mounting (Inverter Only) Or Floor Stand	Wall Mounting (Inverter Only) Or Floor Stand	Wall Mounting (Inverter Only) Or Floor Stand

## Battery Storage

Product Code	SEF1A60G1	SEF1A60G2	SEF1A60G3
Nominal Voltage (V)	51.2		
Operating Temperature (Charge) (C°)	Integrated heating below 5		
Operating Temperature (Discharge) (C°)	-20 to +60		
Ambient Temperature (C°)	-15 to +55		
Relative Humidity (%)	65±20		
Charging Current (kW)	5.2		
Recommended Charging Current (A)	50		
Maximum Charge Current (A)	100		
Battery Voltage Range (V)	44.8 - 56.2		
Max. Charge/ Discharge Power (kW)	6		
Max. Charge/ Discharge Current (A)	120		
Battery Type	LiFePo4 (Lithium Ferrous Phosphate)		

## PV Input

Product Code	SEF1A60G1	SEF1A60G2	SEF1A60G3
Max. Input Power (kW)	9 (150%)		
Max. PV Voltage (V)	550		
MPPT Range (V)	80-500		
Full MPPT Range (V)	170-500		
Normal Voltage (V)	360		
Startup Voltage (V)	100		
Max. Input Current (A)	18.5 x 2		
Max. Short Current (A)	26 x 2		
No. of MPP Tracker / No. of PV strings	2 / 2 Independent Strings		

## Efficiency

Product Code	SEF1A60G1	SEF1A60G2	SEF1A60G3
App	Powered By Sync Energy		
Warranty	10 Years / 6000 Cycles		
Display & Communication Interfaces	LCD, LED, RS485, CAN, Wi-Fi Ethernet		
Certification & Approvals	G98/G99 EN62109-1, EN62109-2		
EMC	EN61000-6-2, EN61000-6-3		

## Protection & Safety

Product Code	SEF1A60G1	SEF1A60G2	SEF1A60G3
PV Reverse Polarity Protection		YES	
Over Current/ Voltage Protection		YES	
Anti-Islanding Protection		YES	
AC Short Circuit Protection		YES	
Residual Current Detection		YES	
Ground Fault Monitoring		YES	
Insulation Resistance Detection		YES	
Enclosure Protect Level		IP65	
AC/DC Surge protection	Type II Intergrated Protection		
Topology	Transformerless		
Cooling Method	Intelligent Fan		
Operating Altitude (m)	< 2000		
Noise Emission (dB)	< 25		
Standby Consumption (W)	< 10		
Fire Suppression Module	Intergrated In Each Battery Module		

## List of Fault Codes

Product Fault Type	Fault code	Fault name
PV Malfunction	A01	The actual PV access method does not match the settings
	A04	PVs1 overvoltage
	A05	PVs2 overvoltage
	A16	PVs1 reverse connection
	A17	PVs2 reverse connection
Battery Malfunction	B01	PCS battery overvoltage
	B02	PCS battery undervoltage
	B06	Abnormal battery communication
	B09	Battery system failure
	B17	Battery overtemperature
	B18	Low temperature of the battery
	B22	SOC is too low
Grid Malfunction	C01	Loss of power grid (silos)
	C02	Grid voltage imbalance
	C05	Grid overvoltage
	C06	Grid undervoltage
AC-side fault	F01	Overall hardware protection
	F03	Inverter R phase overflow
	F06	The grid-connected three-phase current is unbalanced
	F08	Leakage current overcurrent
	F10	Relay group 1 (grid connection) fault
	F11	Relay set 2 (off-grid) fault
	F21	Off-grid overvoltage
	F22	Off-grid undervoltage
Permanent Malfunction	H01	PV overflow
	H02	BDC overflow
	H03	The reverse change is overflowing
	H09	Relay failure
Internal Alarm	I01	Fan 1 (internal) fault
	I02	Fan 2 (external) fault
	I14	DSP upgrade failed
External Alarm	Day 01	Abnormal meter communication
	Day 02	Meter & CT installation error
	J03	Battery SOH alarm
	Day 06	PV overvoltage alarm
	Day 11	CT direction is wrong
	Day 13	Battery SOC low alarm
	Day 16	Battery software mismatch
	Day 22	Fire alarm

## Technical support

Contact Sync Energy technical support at:  
[support@sync.energy](mailto:support@sync.energy) or via the website at  
[www.sync.energy](http://www.sync.energy)

**Sync Energy is a trading name of Luceco PLC**

Luceco PLC Stafford Park 1, Telford,  
TF3 3BD, England

(EU) Luceco SE C/ Bobinadora 1-5,  
08302 Mataró, Spain