

Brief Product Description

This flush recessed range of consumer units offer a flexible solution to 18th Edition Wiring Regulations BS7671.

Available in a 16 and 22 Module sizes providing 14 & 20 useable ways without surge and 13 & 19 useable ways with. Fitted with a 100A Main switch.

MCB, RCBO, AFDD, and Control Devices can be fitted into the Consumer Unit depending on the circuit requirements.

A large range of consumer unit accessories are available, please visit the BG website for more information.

Features

- 100A main switch (fitted)
- Type 2 SPD - 1 module (pre-wired)
- 68mm Flush board depth
- Large rear knockouts (Upper row)
- Convenient cable entry knockouts to the sides, top and bottom
- Optional Cover lock
- Backed out and retained terminal screws

Technical Specifications

Installation Method	Recessed
Number of Phases	1
Protection Options	MCB, RCBO, AFDD, RCD, SPD
IP Rating	IP2XC
Colour	White - RAL9016(Traffic White)
Main Switch Rated Current	100A
Rated Operational Voltage	230V
Frequency	50Hz
Rated & Insulation Voltage (Ui)	500V AC
Type of Supply Voltage	AC
Rated Impulse Withstand Voltage (Uimp)	4kV
Rated Conditional Short Circuit Current (Icc)	16kA
Pollution Degree	2
UV Stability	Yes
Main Switch Terminal Capacity	35mm ²
Main Switch Terminal Torque	2.5Nm
Recommended Screwdriver Type	Pozidrive 2
Standards	Consumer Unit - BS/EN61439 Main Switch - EN/IEC 60947-3



Consumer Unit Part Codes

Cat No	Modules	T2 Surge	Available Ways
CFF16M14	16 Module	N	14
CFF22M20	20 Module	N	20
CFF16MS13	16 Module	Y	13
CFF22M19	20 Module	Y	19

Product Images



Dimensional Line Drawing

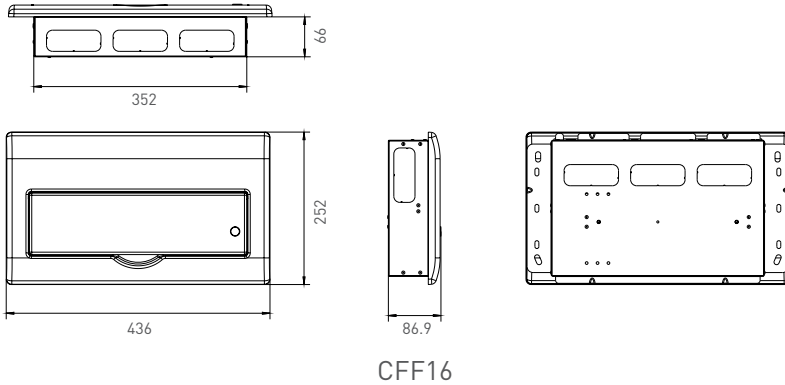

Dimensions of product

Height: 252 mm

Width: 436 mm

Depth: 86.9 mm

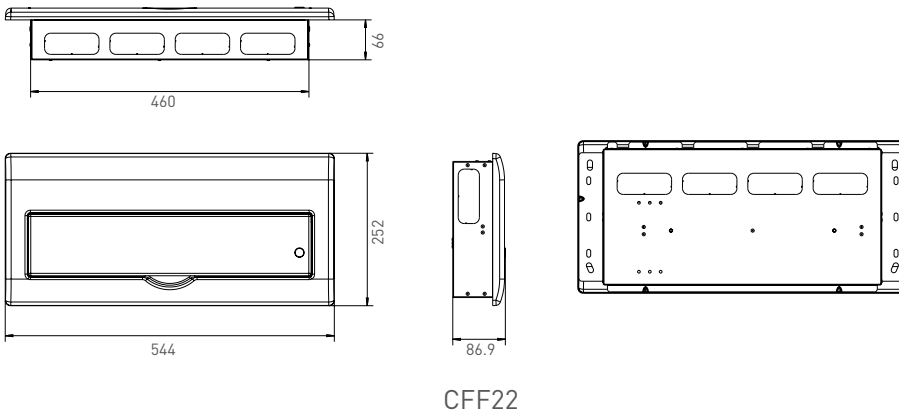

Dimensions of product

Height: 229.9 mm

Width: 208.4 mm

Depth: 115.9 mm

Consumer Unit Knockout Detail per face

Consumer unit	Top	Bottom	Base	Sides
CFF16	3 x 92mm x 30mm	3 x 92mm x 30mm	3 x 92mm x 30mm	L- 1 x 92mm x 30mm, R- 1 x 92mm x 30mm
CFF22	4 x 92mm x 30mm	4 x 92mm x 30mm	4 x 92mm x 30mm	L- 1 x 92mm x 30mm, R- 1 x 92mm x 30mm

Rated Diversity Factor (RDF)/Values of assumed loading

Number of Outgoing	Assumed Loading
2 and 3	0.8
4 and 5	0.7
6 to 9 Inclusive	0.6
10 and Above	0.5

Note: RDF only applies to continuously and simultaneously loading circuits. In principle this means adjacent circuit breakers having a load 'on' time exceeding 30 minutes or where a load not exceeding 30 minutes has an 'off' time less than the 'on' time will need to have the rating diversity factor applied as indicated.

Maintenance

To maintain the high quality appearance of this product BG Electrical recommend the use of a soft damp cloth periodically to clean the surfaces

ONLY CLEAN THE OUTSIDE OF THE CONSUMER UNIT.



Guarantee

BG Electrical Circuit Protection products are guaranteed against faulty materials and workmanship for a period of 10 years from date of delivery.

Products will be repaired or (at BG Electrical's discretion) replacements will be supplied or (at BG Electrical's discretion) a credit note will be issued. This guarantee is subject to BG Electrical's conditions of sale and in particular to the following conditions being met.



1. Notification of any defect is given as soon as reasonably practicable after becoming apparent, and the products then returned to BG Electrical.
2. The products have only been operated under normal operating conditions and have only been subject to normal use.
3. No work (other than normal and proper maintenance) has been carried out to the products without BG Electrical's prior written consent.
4. The products have been assembled, or incorporated into other goods, by a qualified and recognised electrician and only in accordance with any instructions issued by BG Electrical.
5. The defect has not arisen from an item manufactured or supplied by a person other than BG Electrical.

This guarantee does not affect any customer statutory rights.

All components used in a BG Electrical enclosure, must be supplied by BG Electrical.

The use of any other components will negate compliance to BS 61439 and the BG Electrical guarantee. Failure to fit the enclosure in accordance with these instructions will invalidate the guarantee.