

TEMPUS CONNECT SURFACE PINSPOT

EMERGENCY LIGHTING
LEMEDSWCLPW / LEMEDSWOLPW



SPECIFICATIONS:

- **Input Voltage:** AC220-240V 50/60Hz
- **Emergency Duration:** >3 Hours
- **Recharge Time:** 24 Hours
- **Operating Environmental Temperature:** 5°C to 45°C
- **Battery:** LiFePO₄ 3.2V 3000mAh

ENSURE ELECTRICAL SUPPLY IS DISCONNECTED/ ISOLATED BEFORE COMMENCING INSTALLATION

NOTE - To comply with regulations, installation must be carried out by qualified electrician and in accordance with the current IEE Wiring Regulations (BS7671) and Building Regulations

OPERATION

The luminaire should be connected to the mains supply for a minimum of 24 hours before operating in emergency mode as the batteries need to be fully charged before they will provide their full rated duration.

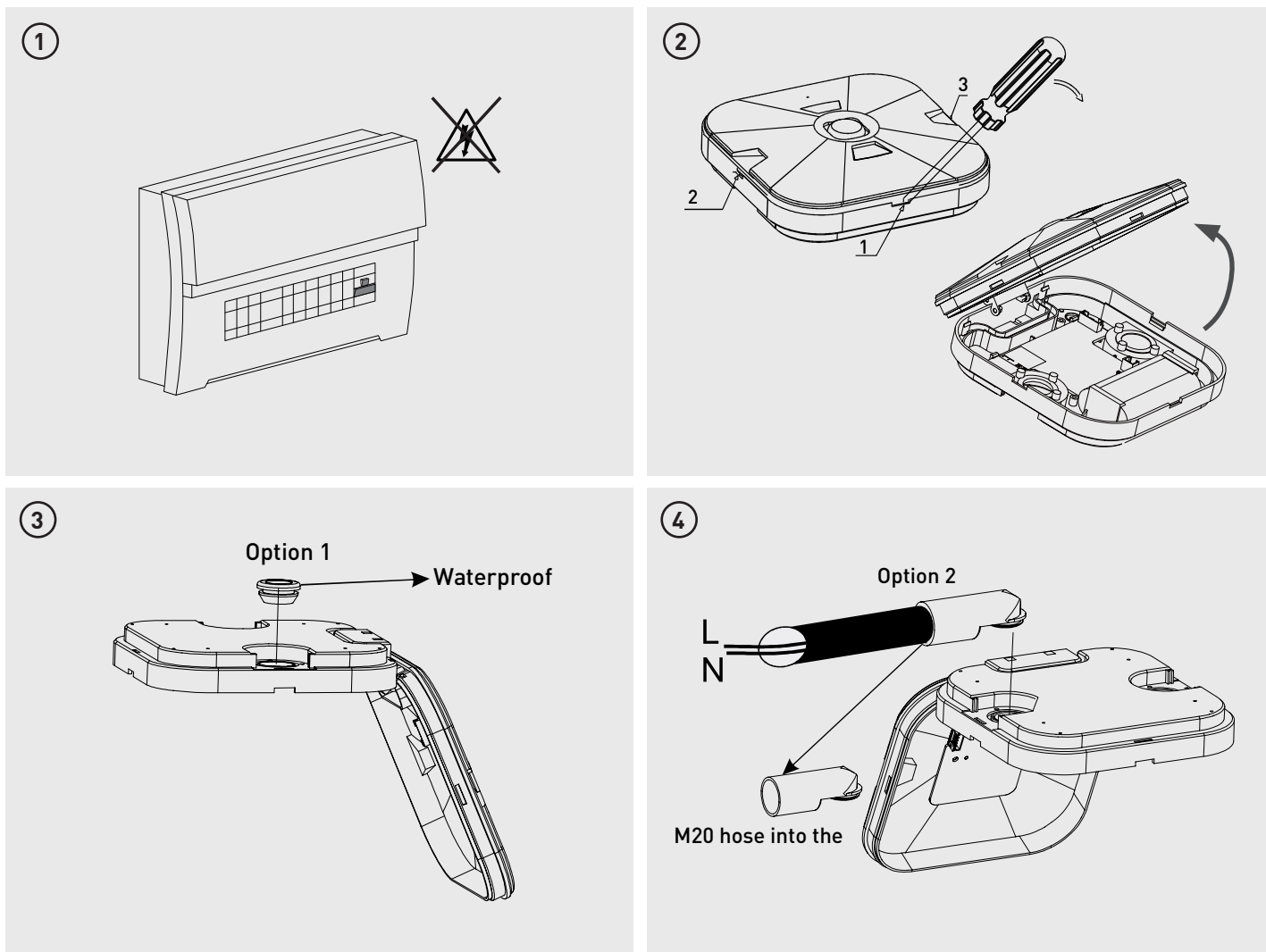

<p>Tech Help Line UK - 0330 0249 279 Non UK - +44 (0)1952 238 100 Supplied by Luceco plc, Telford, TF3 3BD, UK. Visit our website at www.luceco.com</p>	<p>Servicio de asistencia telefónica UK - 0330 0249 279 Non UK - +34 93 829 55 74 Luceco SE, Barcelona, 08460, ES. Visite nuestra web en www.luceco.com</p>
--	--

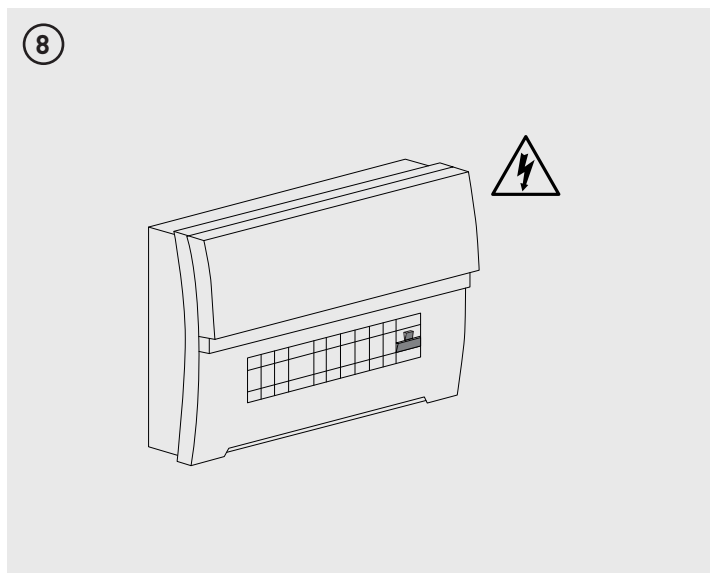
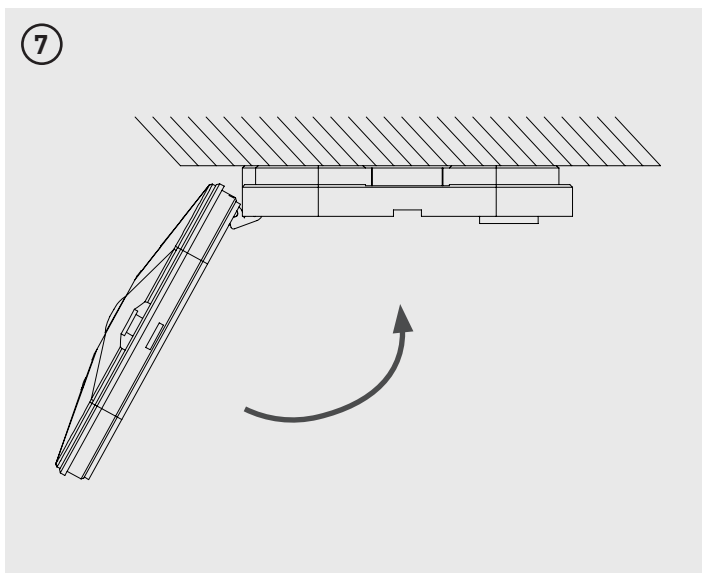
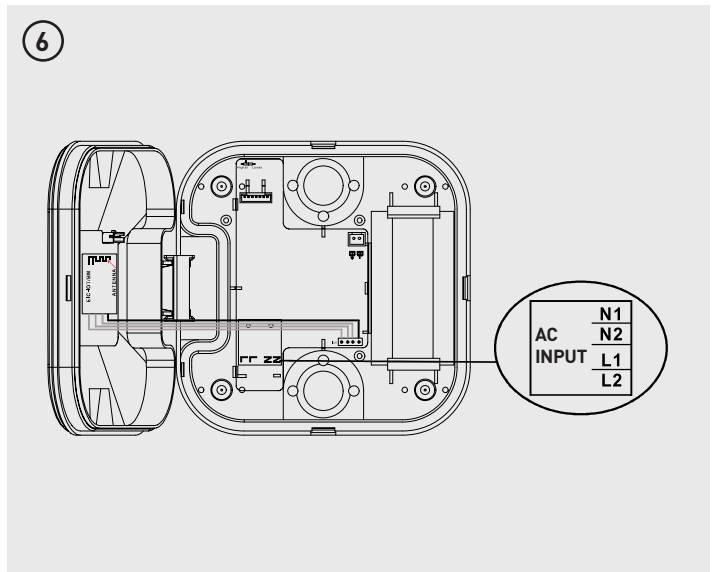
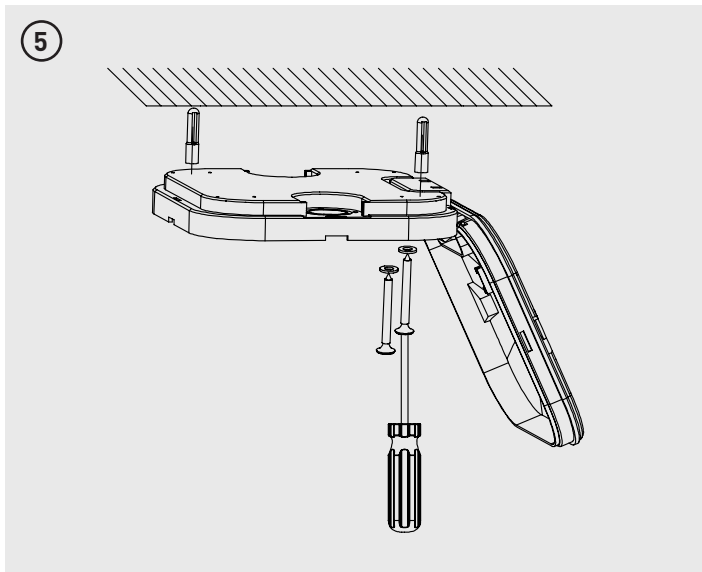

Tech Help Line
 UK - **0330 0249 279**
 Non UK - **+44 (0)1952 238 100**
 Supplied by
Luceco plc, Telford, TF3 3BD, UK.
 Visit our website at www.luceco.com

Servicio de asistencia telefónica
 UK - **0330 0249 279**
 Non UK - **+34 93 829 55 74**
Luceco SE, Barcelona, 08460, ES.

Visite nuestra web en www.luceco.com

TEMPUS CONNECT
SURFACE PINSPOT
 EMERGENCY LIGHTING
 LEMEDSWCLPW / LEMEDSWOLPW

RECOMMENDED ROUTINE PROCEDURE

The following test is designed to ensure the continued protection of your premises and occupants. Because of the possibility of a failure of the normal lighting supply occurring shortly after a period of testing, all tests should, whenever possible, be undertaken at times of least risk, e.g. during daylight hours.

ONCE A DAY

Visual inspection of battery charge LED.

ONCE A MONTH

Each unit should be energized from its battery for about 30 seconds by simulation of a failure of the normal lighting supply to ensure the lamp operates in the emergency condition.

ONCE A YEAR

Each unit should be energized from its battery for a 3 hour discharge test.

ROUTINE TEST RECORD

Month	Test	First Year		Second Year		Third Year		Fourth Year		Fifth Year	
		Signed	Date	Signed	Date	Signed	Date	Signed	Date	Signed	Date
1	Function										
2	Function										
3	Function										
4	Function										
5	Function										
6	Function										
7	Function										
8	Function										
9	Function										
10	Function										
11	Function										
12	Function										