

## SUSPENDED LINEAR LITERA IP44

LIT12Wxxx940



This Luminaire contains two light sources of Class <C>



- ES** Esta luminaria contiene dos fuentes luminosas de clase <C>
- FR** Ce luminaire contient deux sources lumineuses de classe <C>
- IT** Questo apparecchio di illuminazione contiene due sorgenti luminose di Classe <C>
- PT** Esta luminária contém duas fontes de luz de classe <C>
- DE** Diese Leuchte enthält zwei Lichtquellen der Klasse <C>

<p><b>ASSEMBLY AND INSTALLATION</b> <b>EN</b></p> <ul style="list-style-type: none"> <li>This product is only suitable for indoor use</li> <li>This product must be disconnected before insulation resistance testing of the lighting circuit</li> </ul>	<p><b>MONTAJE E INSTALACIÓN</b> <b>ES</b></p> <ul style="list-style-type: none"> <li>Este producto sólo es adecuado para uso interior</li> <li>Este producto debe ser desconectado antes de ensayar, en el circuito eléctrico, la resistencia de aislamiento</li> </ul>	<p><b>NOTICE D'ASSEMBLAGE ET DE MONTAGE</b> <b>FR</b></p> <ul style="list-style-type: none"> <li>Ce produit est uniquement réservé à une installation intérieure</li> <li>Ce produit doit être déconnecté avant tout test de résistance du circuit d'éclairage</li> </ul>
<p><b>MONTAGGIO E INSTALLAZIONE</b> <b>IT</b></p> <ul style="list-style-type: none"> <li>Questo prodotto è adatto solo per uso interno</li> <li>Questo prodotto deve essere scollegato prima del test di resistenza di isolamento del circuito di illuminazione</li> </ul>	<p><b>MONTAGGIO E INSTALLAZIONE</b> <b>PT</b></p> <ul style="list-style-type: none"> <li>Este produto é adequado apenas para uso interno</li> <li>Este produto deve ser desconectado antes do teste de resistência de isolamento do circuito de iluminação</li> </ul>	<p><b>ZUSAMMENBAU UND INSTALLATION</b> <b>DE</b></p> <ul style="list-style-type: none"> <li>Nur zur Verwendung in trockenen Räumen</li> <li>Vor der Isolationswiderstandsprüfung muß das Produkt von der Spannungsversorgung getrennt werden</li> </ul>

**LIGHT SOURCE WARNING**  
The light source contained in this luminaire shall only be replaced by the manufacturer or service agent or a suitably qualified person

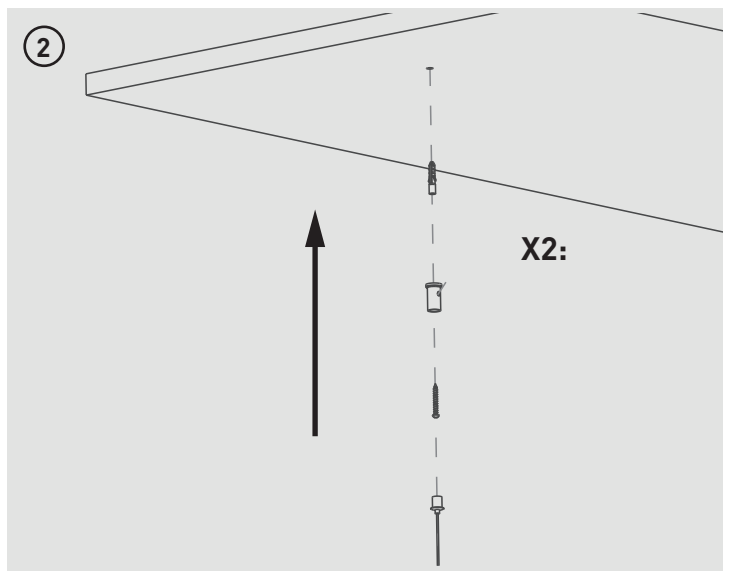
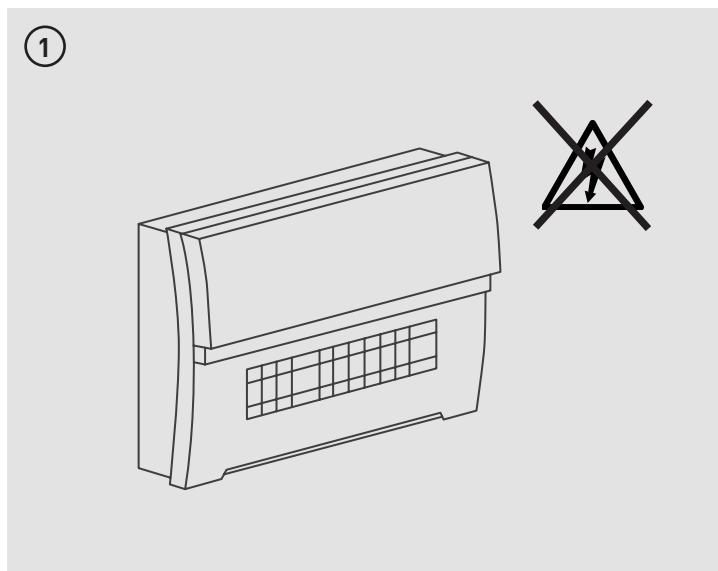
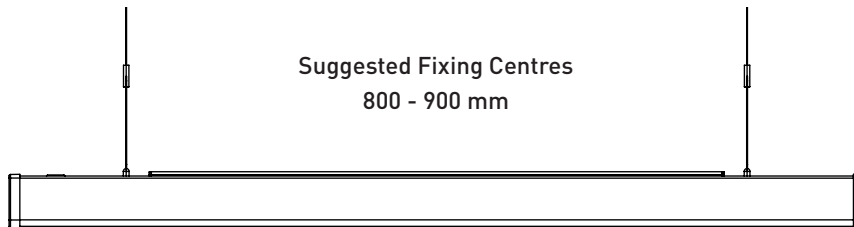

Tech Help Line  
UK - 0330 0249 279  
Non UK - +44 (0)1952 238 100  
Luceco plc, Telford, TF3 3BD, UK.  
Visit our website at [www.luceco.com](http://www.luceco.com)

Servicio de asistencia telefónica  
UK - 0330 0249 279  
Non UK - +34 93 829 55 74  
Luceco SE, Barcelona, 08460, ES.  
Visite nuestra web en [www.luceco.com](http://www.luceco.com)

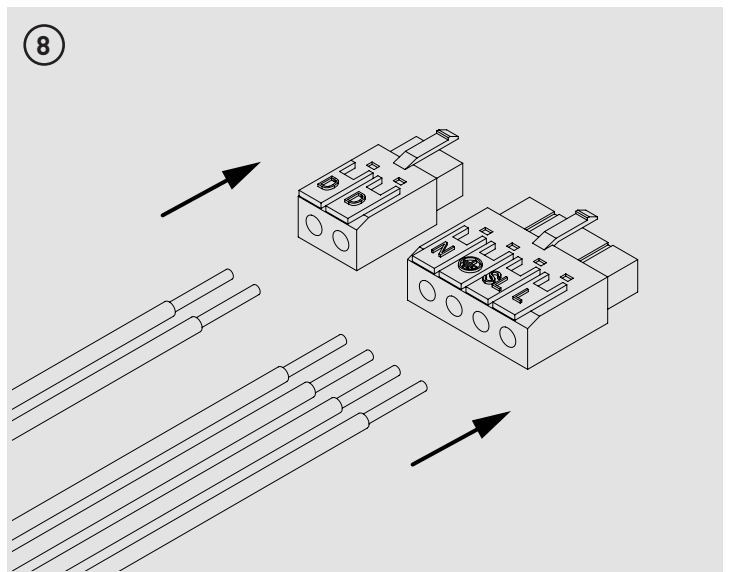
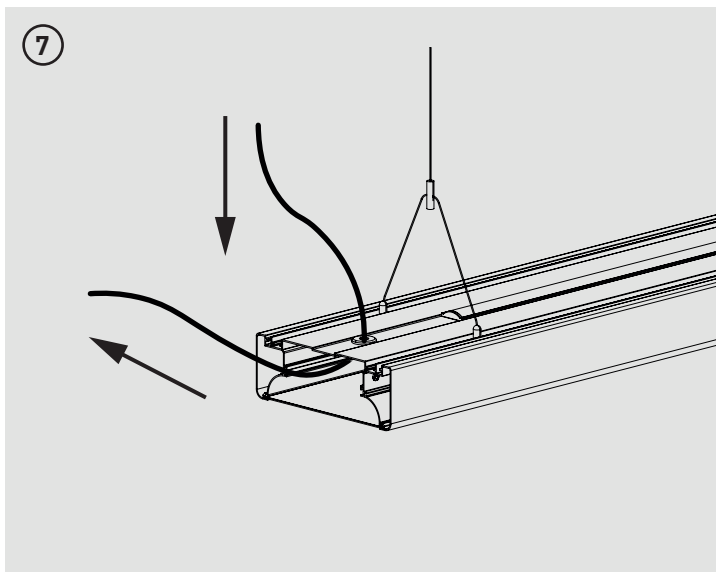
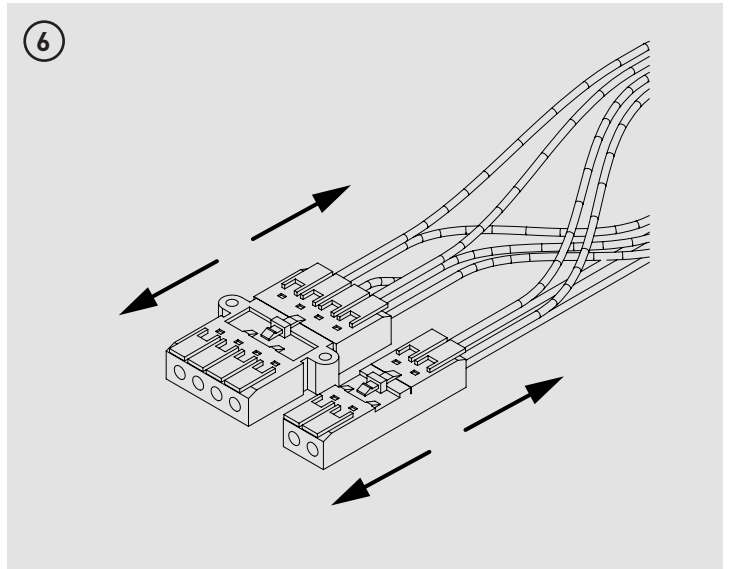
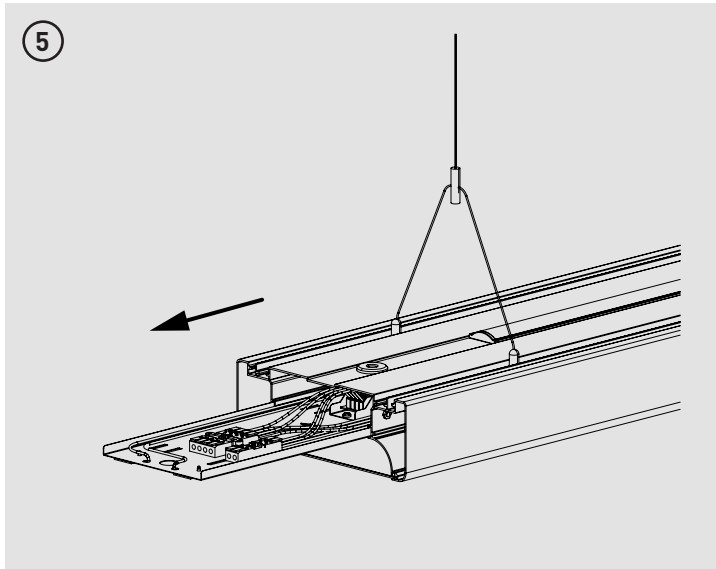
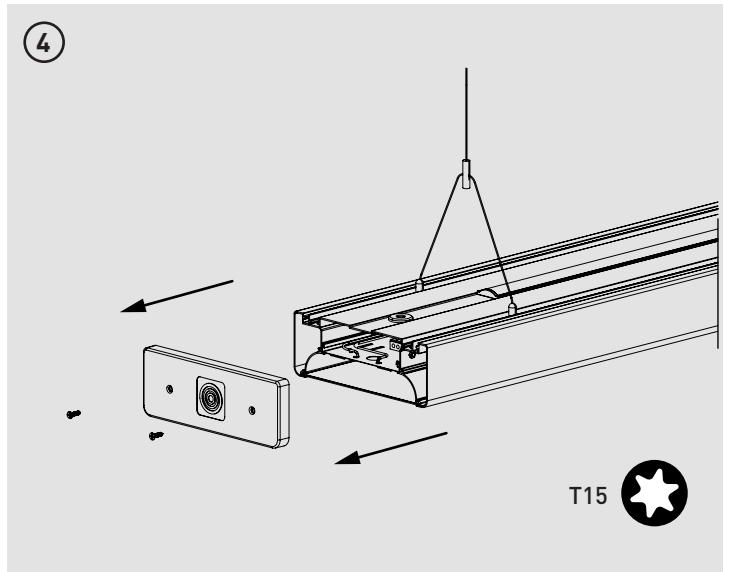
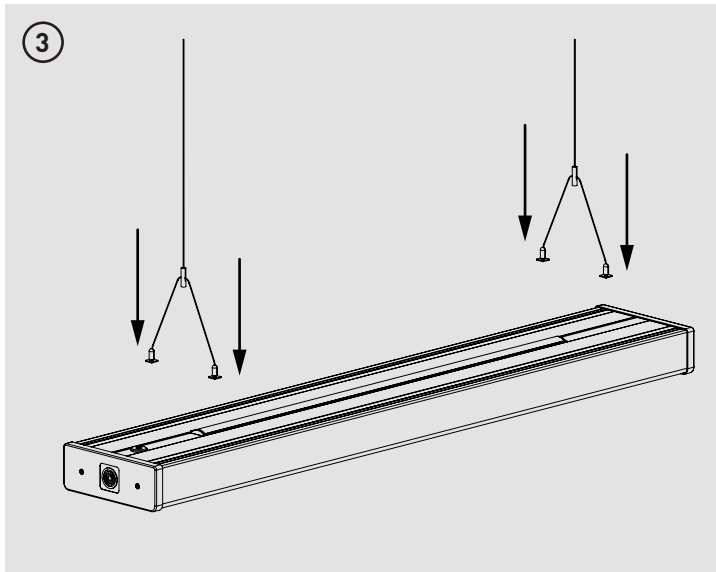

Tech Help Line  
 UK - 0330 0249 279  
 Non UK - +44 (0)1952 238 100  
 Luceco plc, Telford, TF3 3BD, UK.

Visit our website at [www.luceco.com](http://www.luceco.com)

Servicio de asistencia telefónica

UK - 0330 0249 279  
 Non UK - +34 93 829 55 74

Luceco SE, Barcelona, 08460, ES.

Visite nuestra web en [www.luceco.com](http://www.luceco.com)

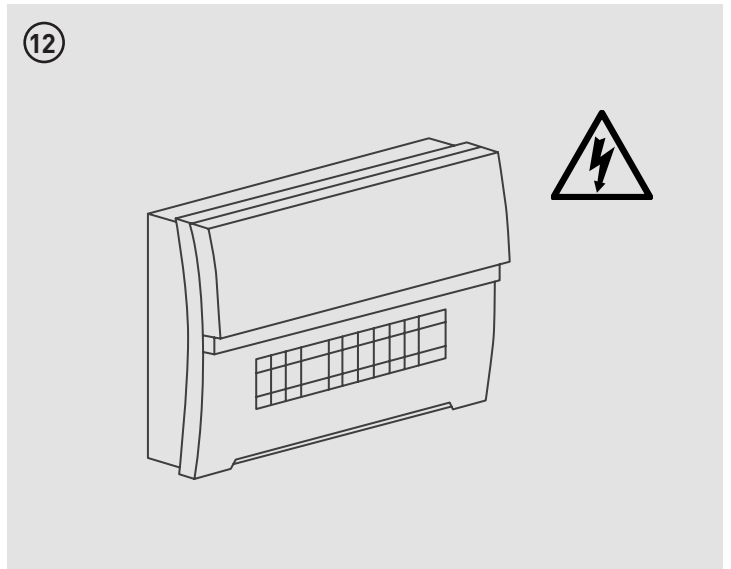
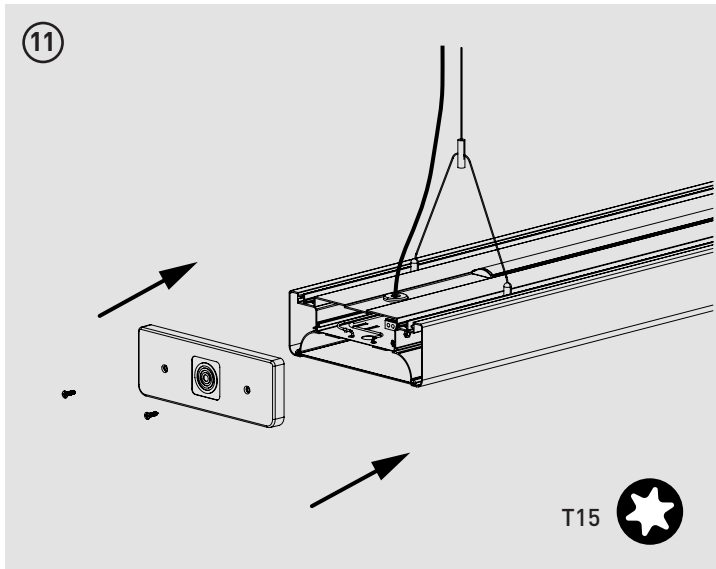
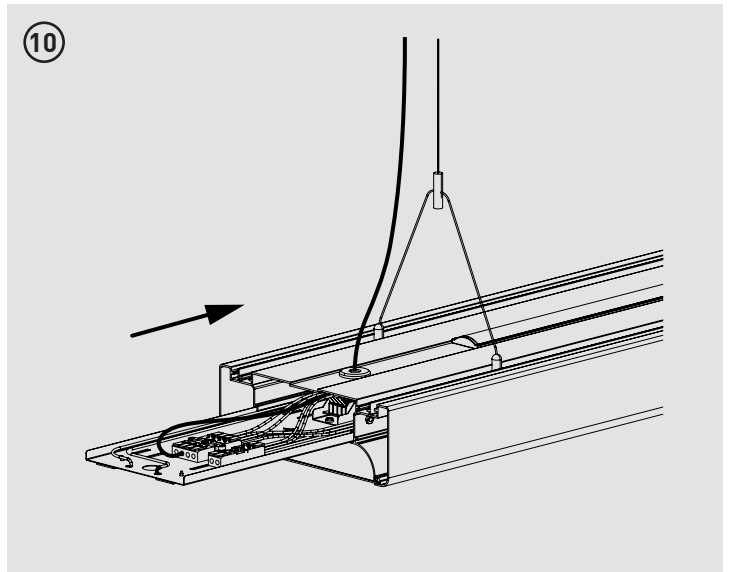
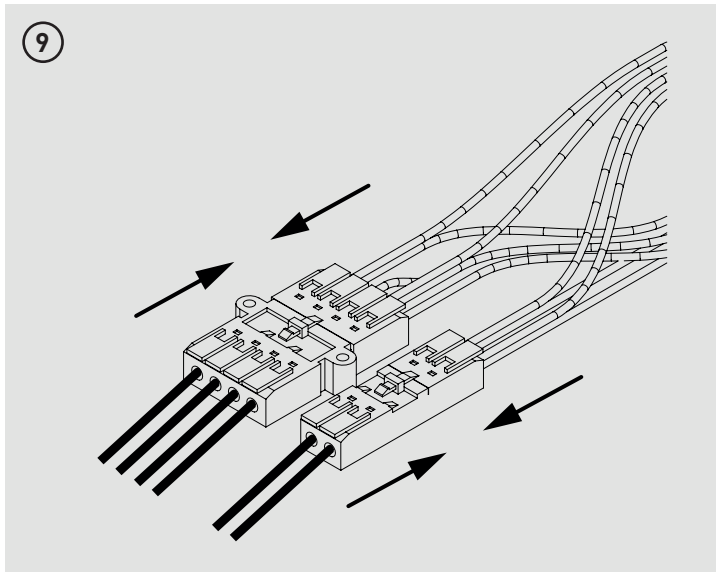

Tech Help Line  
 UK - **0330 0249 279**  
 Non UK - **+44 (0)1952 238 100**  
**Luceco plc**, Telford, TF3 3BD, UK.  
 Visit our website at [www.luceco.com](http://www.luceco.com)

Servicio de asistencia telefónica  
 UK - **0330 0249 279**  
 Non UK - **+34 93 829 55 74**  
**Luceco SE**, Barcelona, 08460, ES.  
 Visite nuestra web en [www.luceco.com](http://www.luceco.com)

## WIRING DIAGRAMS

**FIXED OUTPUT**  
LIT12WxxSxxx-02

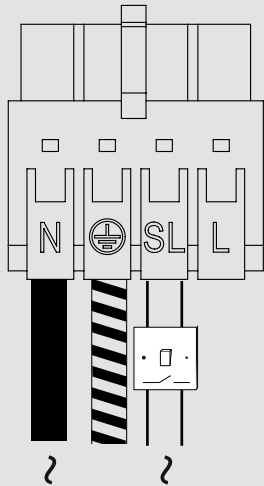

**EMERGENCY**  
LIT12WxxExxx-02

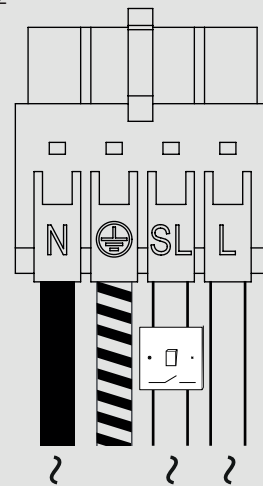

**PLATFORM WIRELESS  
(INCLUDING EMERGENCY + ELT EMERGENCY)**  
LIT12WxxLPWxxx-02  
LIT12WxxELPWxxx-02  
LIT12WxxELTPWxxx-02

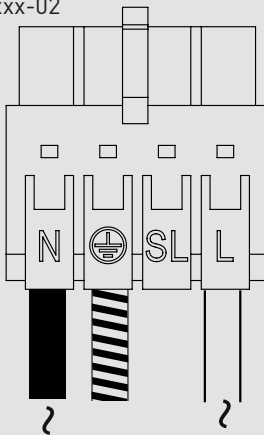

**DALI DIMMABLE**  
LIT12WxxDxxx-02

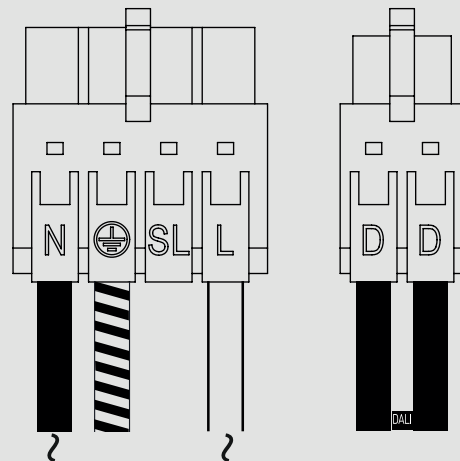

**DALI DIMMABLE WITH DALI EMERGENCY**  
LIT12WxxDEDxxx-02

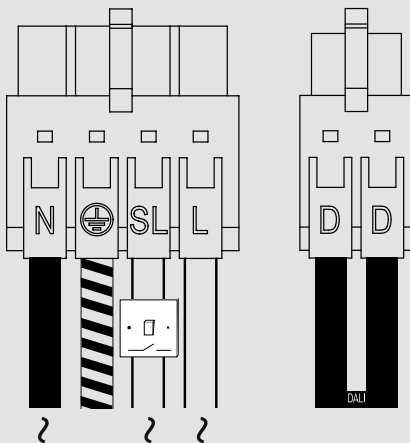

**SWITCH DIM**

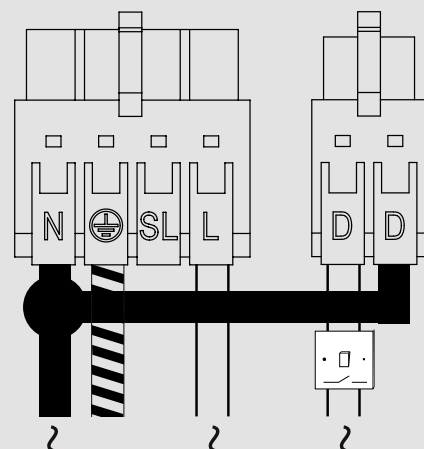

Tech Help Line

UK - **0330 0249 279**  
Non UK - **+44 (0)1952 238 100**

**Luceco plc**, Telford, TF3 3BD, UK.

Visit our website at [www.luceco.com](http://www.luceco.com)

Servicio de asistencia telefónica

UK - **0330 0249 279**  
Non UK - **+34 93 829 55 74**

**Luceco SE**, Barcelona, 08460, ES.

Visite nuestra web en [www.luceco.com](http://www.luceco.com)