

## TITAN ALLinONE HIGH BAY EMERGENCY PACK

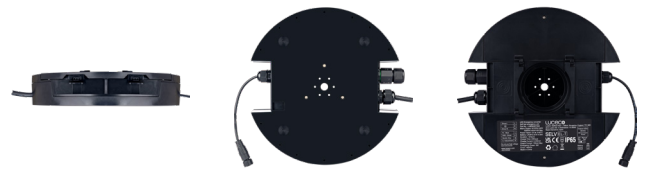

### Product Features

- Self-Test as standard, with on board switch for maintained mode
- Lithium battery with 5 year warranty
- Slimline design make for a sleek install
- Easily replaceable LiFePO4 6.4V 3.6Ah battery



### Product Drawing

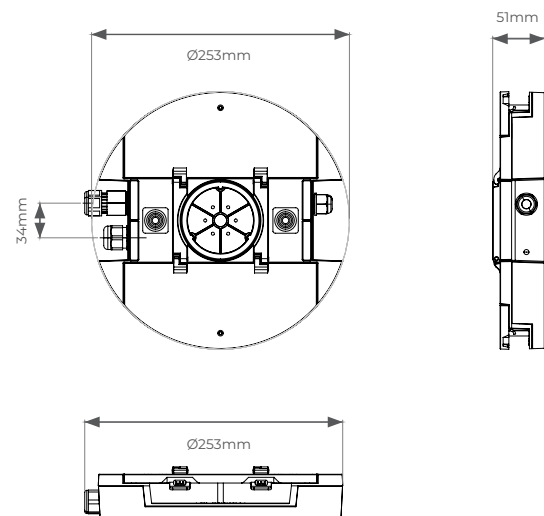

CAT NO.	TYPE
LHBEM3ET8W	Fixed Output + Emergency

CAT NO.	FREQUENCY (Hz)	TEMP RANGE (°C)	AMBIENT TEMP RATED LIFE (°C)
LHBEM3ET8W	50-60	'0 to +45	25°C

STANDARD	DESCRIPTION
60598-1	Luminaire – General requirements
60598-2-1	Luminaire – Particular requirements – Fixed general purpose luminaire
61000-3-2	Electromagnetic compatibility (EMC) – Part 3-2: Limits – for harmonic current emissions
61000-3-3	Lamp controlgear – Part 1: General and safety requirements
61547	Equipment for general lighting purposes – EMC immunity requirements
55015	Limits and methods of measurement of radio disturbance characteristics of electrical lighting and similar equipment

