

OPUS ESSENCE

LOE12: This Luminaire contains a light source of Class <E>

LOE15: This Luminaire contains a light source of Class <E>



ASSEMBLY AND INSTALLATION **EN**

- Suitable for use with mains voltage of 220-240VAC.
- Luminaire suitable for surface mounting or suspension mounting
- This product must be disconnected before insulation resistance testing of the lighting circuit

ZUSAMMENBAU & INSTALLATION **DE**

- Verwendbar mit einer Netzspannung von 220-240VAC
- Die Leuchte ist geeignet für die Aufputzmontage oder mit einer Seilabhangung
- Dieses Produkt muss, vor der Messung des Isolationswiderstandes, von der Stromversorgung getrennt werden.

ASSEMBLAGE ET INSTALLATION **FR**

- Ce luminaire ne peut ˆtre utilise qu'avec une tension secteur de 220-240VAC
- Le luminaire est adapte ˆ un montage en saillie ou en suspension.
- Deconnectez le produit avant de tester la resistance d'isolation du circuit.

MONTAJE E INSTALACI3N **ES**

- Apto para voltajes de 220-240VAC
- Luminaria apta para instalaci3n a superficie o en suspensi3n
- Este producto debe ser desconectado del circuito de iluminaci3n antes del test de aislamiento y resistencia

MONTAGGIO E INSTALLAZIONE **IT**

- Adatto per l'uso con tensione di rete a 220-240VAC
- Apparecchio adatto per il montaggio a soffitto o il montaggio a sospensione
- Questo prodotto deve essere scollegato prima del test di resistenza di isolamento del circuito di illuminazione.

Part Code	Length	Centre Entry	BESA Fixings	Surface & Suspension Fixings
LOE12WLxx	1205mm	✓	600mm	960mm
LOE15WLxx	1505mm	✓	600mm	1220mm

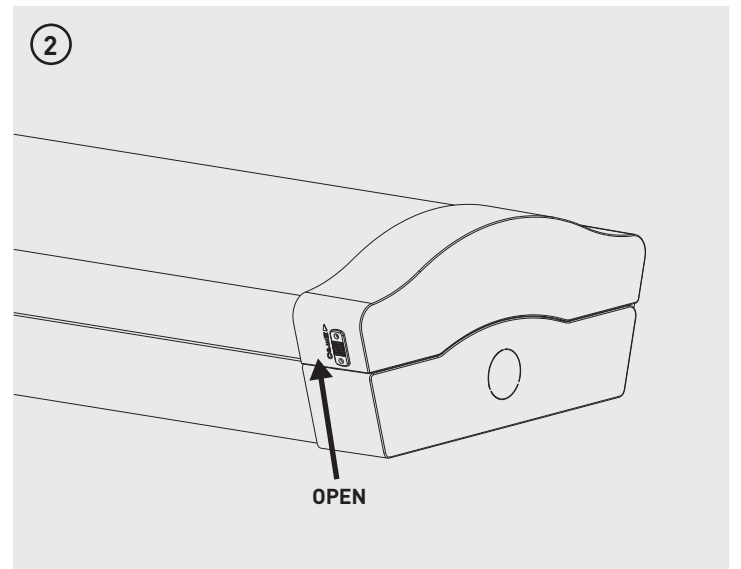
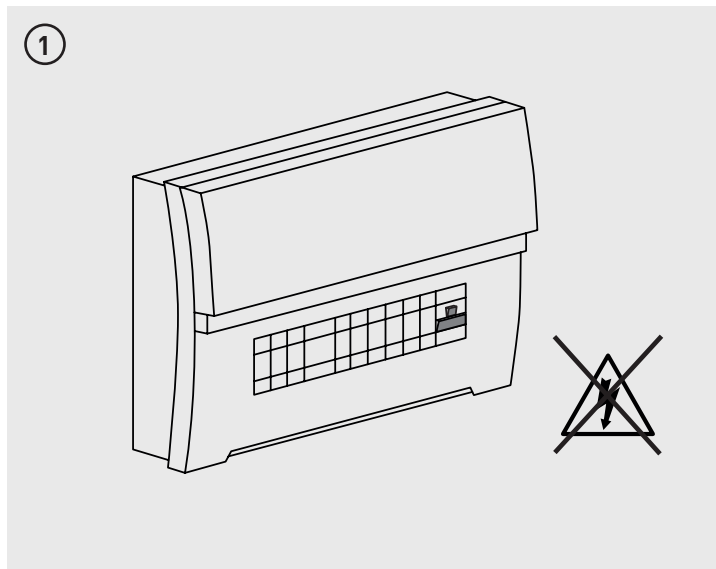
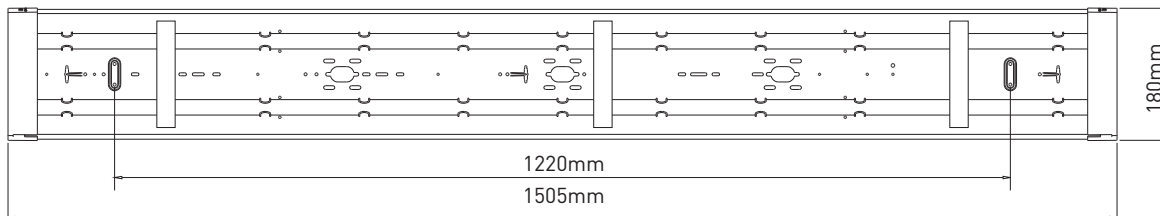
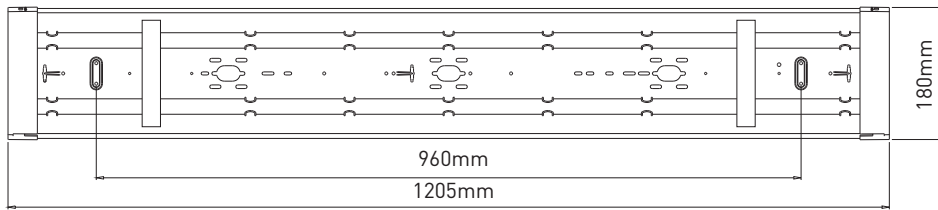

Tech Help Line

UK - 0330 0249 279

Non UK - +44 (0)1952 238 100

Supplied by LUCECO
Stafford Park 1, Telford, Shropshire,
England, TF3 3BD

Visit our website at www.luceco.com

Servicio de asistencia telef3nica

UK - 0330 0249 279

Non UK - +34 93 829 55 74

(EU) Luceco SE
C/ Bobinadora 1-5
08302 Matar3 Spain

Visite nuestra web en www.luceco.com

3

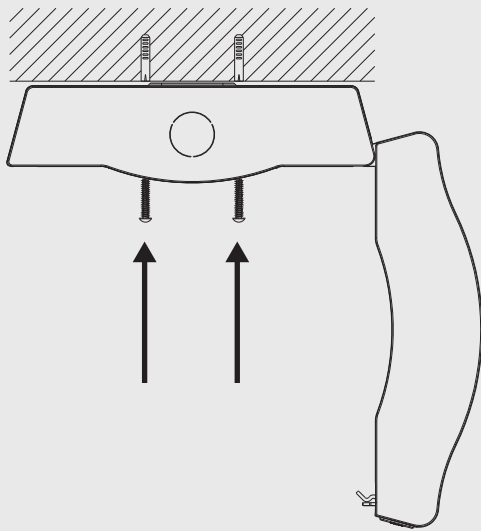

4

Non-dimmable

FR- Non-dimmable
 ES- No dimmable
 IT- Non dimmerabile
 DE- Nicht dimmbar

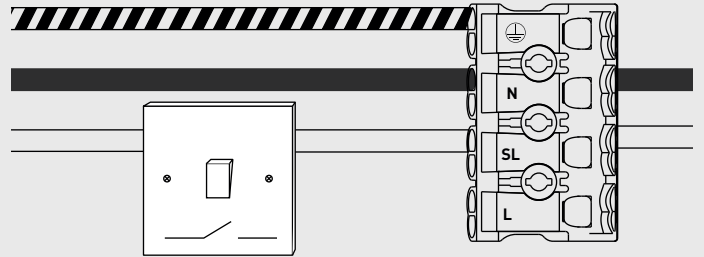

5

Emergency dimmable

FR- Urgence
 ES- Emergencia
 IT- Emergenza
 DE- Notbeleuchtung

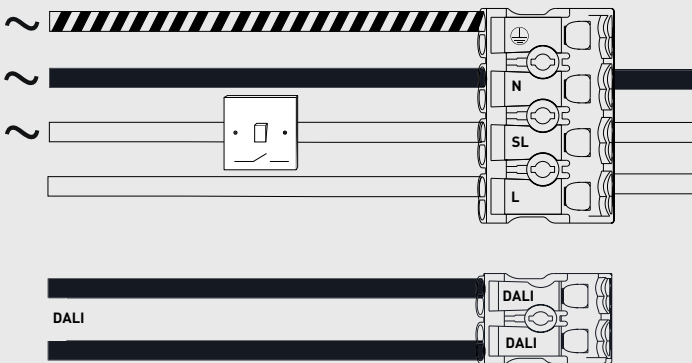

6

Emergency

FR- Urgence
 ES- Emergencia
 IT- Emergenza
 DE- Notbeleuchtung

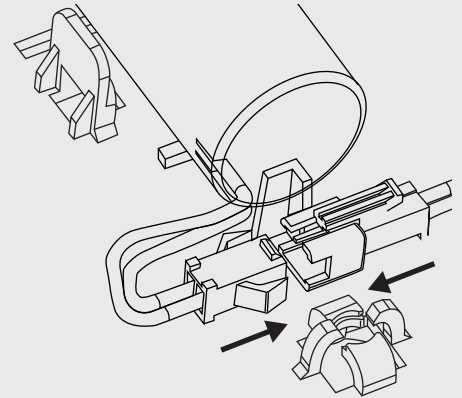

Connect emergency battery

FR- Connecter la batterie d'urgence
 ES- Conecte la batería de emergencia
 IT- Collegare la batteria di emergenza
 DE- Notstromversorgung anschließen

7

DIP switch located on output side of driver

FR- Commutateur DIP situé du côté sortie du pilote
 ES- Interruptor DIP ubicado en el lado de salida del controlador
 IT- Interruttore DIP situato sul lato di uscita del driver
 DE- DIP-Schalter auf der Ausgangsseite des Treibers

4FT POWER CHANGE

Pin 1	Pin 2	Output
On	On	40W
Off	On	34W
On	Off	28W
Off	Off	22W

5FT POWER CHANGE

Pin 1	Pin 2	Output
On	On	60W
Off	On	52W
On	Off	43W
Off	Off	34W

Up = On Off = Down

8

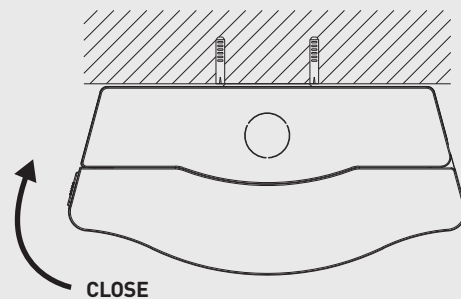

Tech Help Line

UK - 0330 0249 279
 Non UK - +44 (0)1952 238 100

Supplied by LUCECO
 Stafford Park 1, Telford, Shropshire,
 England, TF3 3BD

Visit our website at www.luceco.com

Servicio de asistencia telefónica

UK - 0330 0249 279
 Non UK - +34 93 829 55 74

(EU) Luceco SE
 C/ Bobinadora 1-5
 08302 Mataró Spain

Visite nuestra web en www.luceco.com

9 Use anti tamper screw here to secure

FR- Utilisez ici une vis anti-effraction pour sécuriser
 ES- Utilice aquí un tornillo antisabotaje para asegurar
 IT- Utilizzare qui la vite antimanomissione per fissarla
 DE- Verwenden Sie hier zur Sicherung eine manipulationssichere Schraube

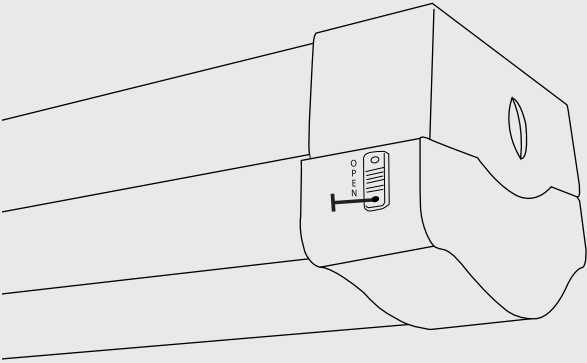

10

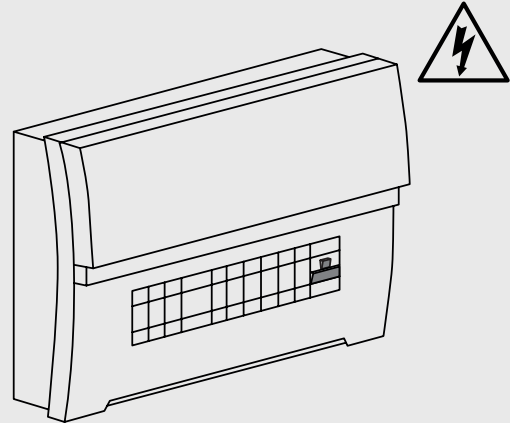

Optional MW Sensor

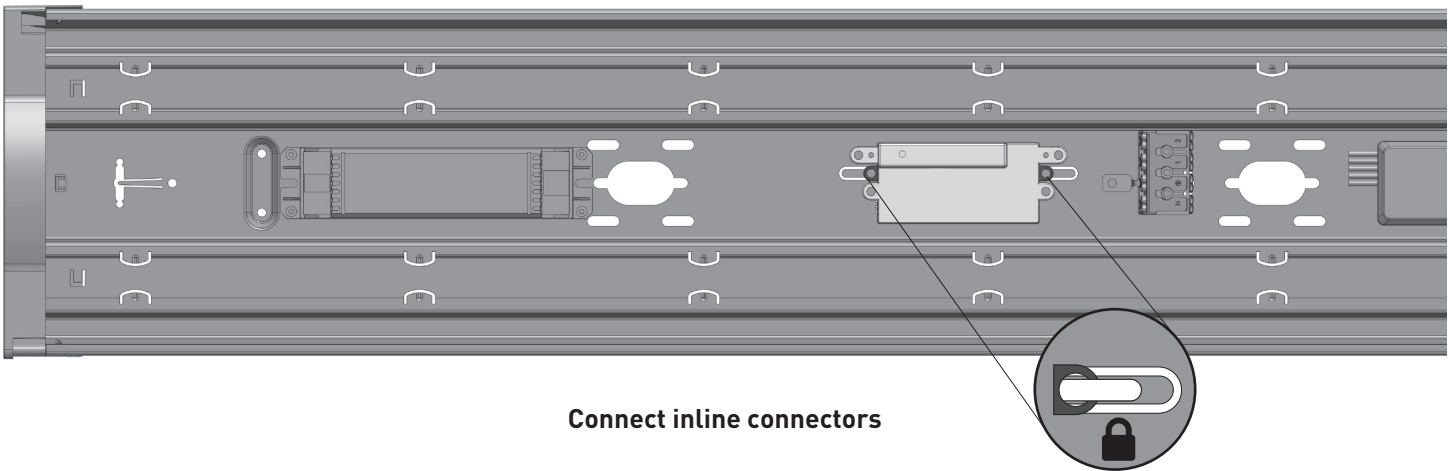

Connect inline connectors

Sensitivity	Hold Time	Daylight Sensor				
		1	2	3	4	5
50%	10min	○	○	○	○	○
	3min	●	○	○	●	○
100%	1min	○	●	○	○	●
	5s	●	●	○	○	●

○ = Off ● = On

Sensitivity : 25% 50% 75% 100%

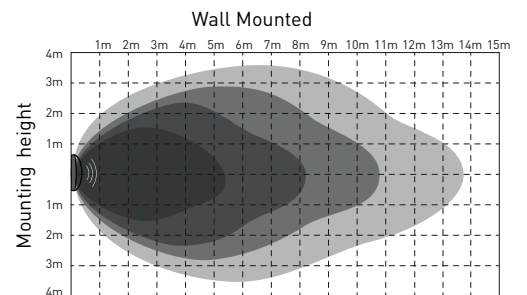
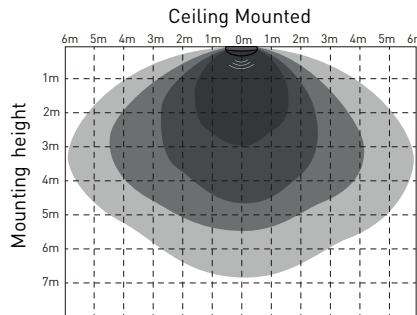

Tech Help Line

UK - 0330 0249 279
 Non UK - +44 (0)1952 238 100
 Supplied by LUCECO
 Stafford Park 1, Telford, Shropshire,
 England, TF3 3BD

Visit our website at www.luceco.com

Servicio de asistencia telefónica

UK - 0330 0249 279
 Non UK - +34 93 829 55 74
 (EU) Luceco SE
 C/ Bobinadora 1-5
 08302 Mataró Spain

Visite nuestra web en www.luceco.com