

OWNER'S MANUAL

BEACH FIRE STAINLESS STEEL GAS GRILL - IN GRAPHITE C10-105-G



For questions regarding performance, assembly, operation, parts, or returns,
contact the experts at MAGMA by calling (562) 627-0500
7:00 a.m. - 4:00 p.m. Pacific Time Monday thru Friday
or e-mail us at mail@MagmaProducts.com

MAGMA[®]
In your element

IMPORTANT, read these instructions carefully before use. Familiarize yourself with the appliance
before connecting it to its gas container. Keep these instructions for future reference.

IMPORTANT SAFETY WARNINGS

READ ALL INSTRUCTIONS BEFORE OPERATING.

- USE OUTDOORS ONLY.
- DO NOT USE THIS APPLIANCE IN ANY ENCLOSED SPACE.
- GRILLS RADIATE HEAT. CLEARANCE FROM COMBUSTIBLES, 24" SIDES AND BACK. NEVER USE UNDER AWNINGS, PATIO COVERS, ETC.
- ALWAYS LIGHT GRILL WITH LID OPEN.
- NEVER LEAVE HOT GRILL UNATTENDED.
- DO NOT OVERHEAT GRILL, SEE OPERATING INSTRUCTIONS
- ALWAYS TURN GRILL OFF AFTER USE.
- USE GLOVE OR HOT PAD WHEN HANDLING HOT GRILL.
- NEVER LEAVE GAS CYLINDERS AND REGULATOR CONNECTED WHEN STORED.
- STORE GAS CYLINDERS IN WELL VENTILATED AREA.
- CAUTION: CHECK FOR GAS LEAKS EACH TIME CYLINDER IS CHANGED.
- NEVER CHECK FOR GAS LEAKS WITH A FLAME!
- DO NOT BLOCK, RESTRICT, OR OTHERWISE OBSTRUCT COMBUSTION OR VENTILATION AIR OPENINGS.
- DO NOT MODIFY THIS APPLIANCE.
- KEEP AREA CLEAR AND FREE FROM COMBUSTIBLE MATERIALS, GASOLINE, AND OTHER FLAMMABLE VAPORS AND LIQUIDS.
- Check the venturi tube is secure and in good condition before connecting the gas container.
- INSTALL CANISTERS IN WELL VENTILATED AREA AND AWAY FROM OPEN FLAME, HEAT SOURCE OR SPARKS. KEEP AWAY FROM OTHER PEOPLE OR FLAMMABLE MATERIALS.

CONTENTS

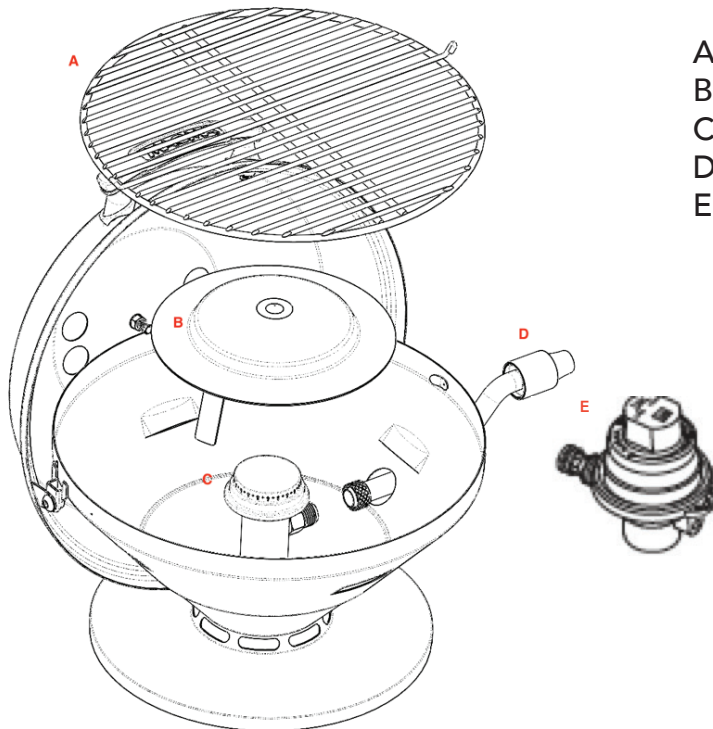

- A. Grill grate
- B. Radiant plate
- C. Burner
- D. Venturi tube
- E. Control valve regulator

BEACH FIRE GAS ASSEMBLY INSTRUCTIONS

1. Remove grill grate by rotating it counter clockwise to release it from the tabs on the side.

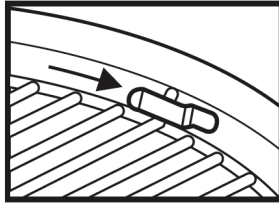

2. Remove radiant plate

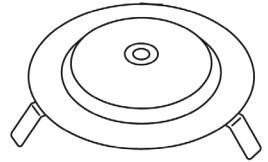

3. Insert venturi tube through hole on the right hand side of the grill base and push into brass fitting. Hand tightening the nut on the brass fitting. Ensure the end of the venturi tube outside the grill is at the highest position.

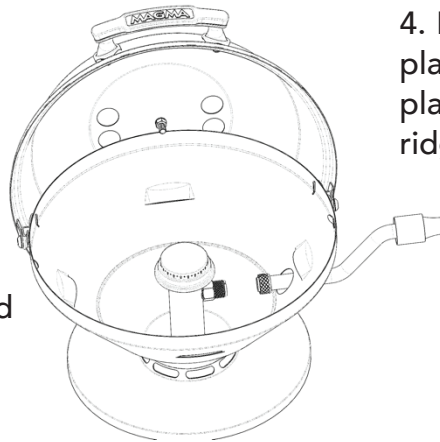

4. Replace radiant plate over burner, placing it on the bowl ridge

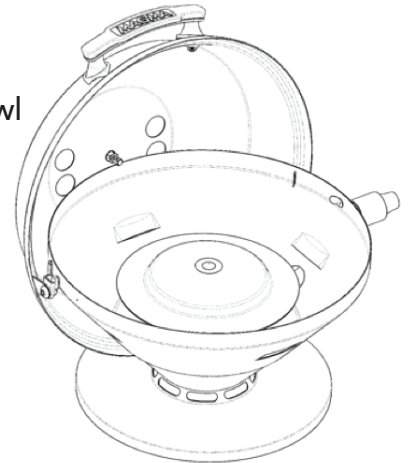

5. Replace cooking grate by rotating grate so that both grill grate tabs slide under holding clips, locking grate and all internal components in securely in place.

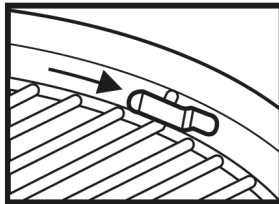

CONNECTING FUEL SOURCE

CONTROL VALVE REGULATOR

- Uses standard 1-lb. disposable propane canisters (DOT-39 NRC).
- Prior to installing valve, become familiar with the valve function and graphics on valve knob. Never force the knob. Always turn or push gently.
- Turn control valve to "lock" and install gas canister being careful not to cross the threads. Check for leaks prior to use, by brushing soapy water solution around threads and orifice hole checking for bubbles.

Valve will feel loose and will rotate easily. Even though the valve feels loose, it is designed that way and will not leak. The valve was designed to be loose fitting in order to allow safe, easy installation and removal of the propane canister and so it easily swings without resistance to fit all applications.

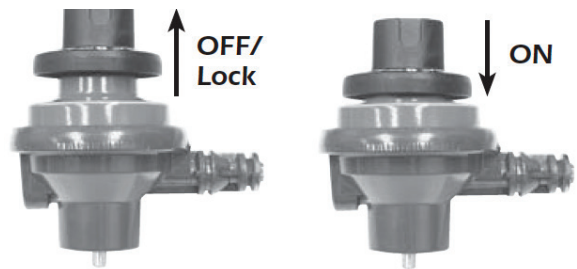
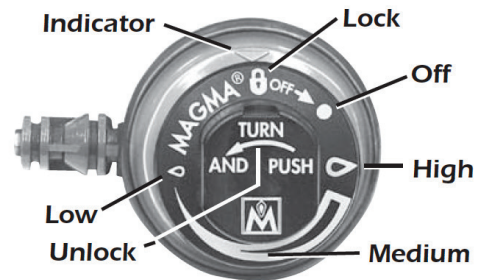

OPERATING PROCEDURES

WARNING: Do not overheat grill. Magma grills do not require pre-heating. Stainless Steel loses anti-corrosive characteristics when subjected to extreme heat. Most grilling is done on low temperature with the lid closed. If medium or high heat is required, grill with lid open.

LIGHTING INSTRUCTIONS

- Open lid during lighting.
- When igniting grill, use a long nozzle butane lighter.
- To ignite grill, first ignite lighter or match flame, put flame to outer edge of Radiant Plate, then turn valve to high "large". Visually check the burner flame, it should be blue with yellow tips. The appliance must not be exposed to flammable vapors or liquids during lighting.
- To grill, cook with lid open or closed.

To help create your own Magma gourmet experience every time you grill, please check these important critical points prior to lighting your grill:

- Venturi tube, burner, threaded burner pipe and valve orifice are free of obstructions, such as spider webs.
- Radiant plate is positioned correctly.
- Grill grate is in locked position under holding clips.
- Turbo Venturi Tube holding nut is tight & doesn't turn when rotating valve position.
- Valve is installed and locked into Turbo Venturi Tube properly.
- Sufficient fuel is available.

Cooking Tips

- The most common mistake when grilling is using too high of a heat setting. Grills become hotter as you cook, so use moderate heat settings when cooking with lid closed.
- Always keep a water spray bottle handy for flare ups and quick cooling if grill overheats.
- Coat the grill grate with vegetable or olive oil to prevent food from sticking.

Storing Tips

- Always disconnect the fuel canister from the valve prior to storing.
- Store the valve and Turbo Venturi Tube in a clean, dry area to protect from corrosion to valve and spider web obstructions in venturi tube.

MAINTENANCE

Complete Disassembly for Cleaning

Keep lower bowl clean. Remove grill grate and radiant plate for easier access to clean lower bowl. Replace radiant plate and grill grate when finished (see page 3)

Stainless steel contrary to popular belief can rust. Most commonly, deposits on surface of the product will trap moisture. It is this moisture that robs stainless steel of oxygen. Oxygen is the element that reacts with stainless steel to form a protective layer of chrome oxide. Robbed of oxygen, this reaction does not take place and "crevice corrosion" or "surface rusting" occurs. To minimize this effect, thoroughly clean your grill with soap and water, rinse with fresh water, and dry. Avoid using stainless steel polishes on grill exterior as most leave a residue that may discolor when grill is heated.

Additionally, stainless steel that is exposed to high heat will change color and texture over time. The "amber" color of grill exterior and internal components is not a failure of the stainless steel and will not affect products operation. When this happens, we recommend using **"Magma Magic" Grill Restorer** to remove the "amber" color and return grill to its original luster. However, prolonged exposure to extreme high heat will cause chromium and nickel to "burn out" of stainless steel. At this point stainless steel will become more susceptible to corrosion and will start to deteriorate. We recommended replacement of internal components as they become seriously deteriorated.

We recommend thoroughly cleaning grill and internal components after each outing. Disassemble interior components and remove all food residue. Use a "Scotch-Brite" pad or similar product and "Easy-Off" oven cleaner for cleaning grills interior components, followed by thoroughly washing with soap and water, rinse with fresh water & dry. AVOID CONTACT OF OVEN CLEANER WITH SKIN, CONTROL VALVE. CAUTION: DO NOT USE ANY TYPE OF ABRASIVE PAD ON EXTERIOR MIRROR FINISH AS IT WILL SCRATCH SURFACE, USE ONLY A SOFT CLOTH. We recommend covering grill between uses. Storage/carry bags are available at Magma retailers or directly from Magma. See our website, **MagmaProducts.com**.

Grill Grates

Clean with brass wire brush while grill is warm. Use Oven & Grill cleaner for burnt-on residue. Wash with soapy water and dry prior to storage.

Control Valve

All valves are set and tested at our factory. Do not attempt to adjust or disassemble the valve. Call Magma if you suspect it is not adjusted properly. Clean valve with a cloth and remove any debris obstructing the orifice.

Repair/Replacement Parts

All replacement parts are readily available directly from Magma. For a complete list of replacement parts visit our website MagmaProducts.com.

TROUBLESHOOTING GUIDE

Problem	Possible Cause	Possible Solution
Burner Will Not Light	No gas flow	<ul style="list-style-type: none">• Check fuel level, replace canister or refill cylinder
	Obstructed gas flow	<ul style="list-style-type: none">• Clean burner, turbo venturi tube, and valve orifice. Remove debris/spider webs
Flare-Up	Excessive cooking temperature	<ul style="list-style-type: none">• Operate only on low when lid is closed• Reduce flame level• Leave lid open• Use water spray to cool
	Grease and/or residue build-up	<ul style="list-style-type: none">• Clean components
	Excessive fat in meats	<ul style="list-style-type: none">• Trim fat from cuts of meat before grilling
	Excessive oils in marinades	<ul style="list-style-type: none">• Use non-oil based marinades
Yellow Sooty Flame	Obstructed gas flow	<ul style="list-style-type: none">• Clean burner, turbo venturi tube, and valve orifice. Remove debris/spider webs
Blow-Out	Flame too low	<ul style="list-style-type: none">• Increase flame
	Wind directly on burner	<ul style="list-style-type: none">• Rotate grill so lid can block the wind
	Obstructed gas flow	<ul style="list-style-type: none">• Clean burner, turbo venturi tube, and valve orifice. Remove debris/spider webs
Hot Spots	Grease or residue build-up	<ul style="list-style-type: none">• Clean components
	Excessive fat in meats	<ul style="list-style-type: none">• Trim fat from cuts of meat before grilling
	Excessive oil in marinades	<ul style="list-style-type: none">• Use non-oil based marinades

LIMITED WARRANTY

Magma Products, LLC. guarantees this product to be free from defects in materials or workmanship to the original consumer. This guarantee is for the periods herein specified when used under normal and reasonable conditions, one (1) year from the date of original purchase. This warranty does not include the cost of property damage or any inconvenience due to the failure of the product. Nor does it cover damage due to misuse, abuse, accident, or damage resulting from transportation of the product. Nor does it include damage resulting from the commercial use of this product. Nor does it include, on stainless steel products, "Surface Rust"; Excessive Corrosion due to exposure to salt water; or Discoloration or Corrosion caused by exposure to excessive heat or failure to properly clean and care for the stainless steel surfaces. If the product fails to operate due to a defect in materials or workmanship during the warranty period, the defective part will be repaired or replaced at Magma's option. If you wish to obtain performance under this limited warranty, you should contact Magma's Customer Service Department via telephone at (562) 627-0500, or via e-mail at mail@MagmaProducts.com, or via U.S. Postal Service mail at "Magma Products, LLC., Attention Customer Service, 3940 Pixie Ave. Lakewood, CA, 90712". The defective part, along with proof of purchase, must be returned postage prepaid to Magma Products, LLC. We suggest that you keep your purchase receipt as we may require reasonable proof of purchase.

In the state of California only, if refinishing or replacement of the product is not commercially practicable, the retailer selling the product, or Magma Products, LLC., will refund the purchase price paid for the product, less the amount directly attributable to use by the original consumer prior to the discovery of the nonconformity. In addition, in the state of California only, you may take the product to the retail establishment from which it was purchased or to any retail establishment selling this product in order to obtain performance under this warranty. All implied warranties, including the implied warranties of merchantability and fitness for a particular purpose, are limited in duration to the express warranty periods specified herein for the parts described herein. Some states do not allow limitations on how long an implied warranty lasts, so the above limitation may not apply to you. Neither Magma dealers, nor the retail establishment selling this product has any authority to make any warranties or to promise remedies in addition to or inconsistent with those stated above. Magma's maximum liability shall not exceed the purchase price of the product paid by the original consumer. Some states do not allow the exclusion or limitation of incidental or consequential damages, so the above limitation or exclusions may not apply to you. The warranty gives you specific legal rights and you may also have other rights which vary from state to state.

MAGMA and the Magma logo are registered trademarks of Magma Products, LLC.

CALIFORNIA PROPOSITION 65 – WARNING – The burning of gas cooking fuel generates some by-products, which are on the list of substances, which are known by the State of California to cause cancer or reproductive harm. California law requires businesses to warn customers of potential exposure to such substances. To minimize exposure to these substances, always operate this unit according to the use and care manual, ensuring you provide good ventilation when cooking with gas.



Magma Products, LLC.
3940 Pixie Avenue, Lakewood, CA 90712 • USA
Phone (562) 627-0500 • mail@MagmaProducts.com
MagmaProducts.com