

# OWNER'S MANUAL

# Cabo™

**Adventurer Series Gas Grill  
Model A10-703**



For questions regarding performance, assembly, operation, parts, or returns, contact the experts at MAGMA by calling **(562) 627-0500** 7:00 a.m. - 5:00 p.m. Pacific Time Monday thru Friday or e-mail us at [mail@MagmaProducts.com](mailto:mail@MagmaProducts.com)

# MAGMA®

U S A

**IMPORTANT**, read these instructions carefully before use. Familiarize yourself with the appliance before connecting it to its gas container. Keep these instructions for future reference.

## IMPORTANT SAFETY WARNINGS

### READ ALL INSTRUCTIONS BEFORE OPERATING.

- USE OUTDOORS ONLY.
- DO NOT USE THIS APPLIANCE INSIDE THE BOAT OR ANY ENCLOSED SPACE.
- GRILLS RADIATE HEAT. CLEARANCE FROM COMBUSTIBLES, 24" SIDES AND BACK. NEVER USE UNDER AWNINGS, PATIO COVERS, ETC.
- USE PROPANE GAS ONLY. FUEL STORAGE SHOULD BE IN COMPLIANCE WITH THE AMERICAN BOAT AND YACHT COUNCIL (ABYC) STANDARDS A-1 (9), MARINE LIQUIFIED PETROLEUM GAS (LPG) SYSTEMS.
- FOR NATURAL GAS APPLICATION CONTACT MAGMA.
- ALWAYS LIGHT GRILL WITH LID OPEN.
- NEVER LEAVE HOT GRILL UNATTENDED.
- USE HOT PAD WHEN HANDLING.
- ALWAYS TURN GRILL OFF AFTER USE.
- NEVER LEAVE GAS CYLINDERS AND REGULATOR CONNECTED WHEN STOWED.
- STORE GAS CYLINDERS IN WELL VENTILATED AREA.
- DO NOT STORE GAS CYLINDERS INDOORS, IN DIRECT SUNLIGHT, BELOW DECKS ON BOATS, OR IN LOCKERS NOT APPROVED FOR BUTANE OR PROPANE STORAGE.
- CAUTION: CHECK FOR GAS LEAKS EACH TIME CYLINDER IS CHANGED.
- NEVER CHECK FOR GAS LEAKS WITH A FLAME!
- DO NOT BLOCK, RESTRICT, OR OTHERWISE OBSTRUCT COMBUSTION OR VENTILATION AIR OPENINGS.
- DO NOT MODIFY THIS APPLIANCE.
- CHECK THAT VALVE SEALING WASHER (A) IS IN PLACE AND IN GOOD CONDITION BEFORE CONNECTING THE GAS CONTAINER.
- INSTALL CANISTERS IN WELL VENTILATED AREA AND AWAY FROM OPEN FLAME, HEAT SOURCE OR SPARKS. KEEP AWAY FROM OTHER PEOPLE OR FLAMMABLE MATERIALS.

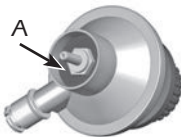

Each Magma® Gas Grill is individually fire tested before it leaves the factory. For this reason, the burner on your grill may be slightly discolored.

## INSTALLATION INSTRUCTIONS

### CONTROL VALVE REGULATOR

- Uses standard 1-lb. disposable propane canisters (DOT-39 NRC 228/286).
- Prior to installing valve, become familiar with the valve function & graphics on valve knob. Never force the knob. Always turn or push gently.
- Turn control valve to "lock" and install gas canister being careful not to cross the threads. Check for leaks prior to use, by brushing soapy water solution around threads and orifice hole checking for bubbles.
- Position valve with gas bottle as shown **(A)**. Gently insert valve stem into valve chamber. Rotate until valve stem key aligns with lock detent allowing valve to fully insert. Rotate gas canister down, so knob faces you **(B)** or straight up **(C)** depending on application. Pull straight out on valve to check that it is locked in place.

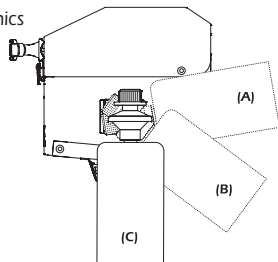

**Valve will feel loose and will rotate easily. Even though the valve feels loose, it is designed that way and will not leak. The valve was designed to be loose fitting in order to allow safe, easy installation and removal of the propane canister and so it easily swings without resistance to fit all applications**

## MOUNT HARDWARE

Fasteners are supplied for Single Mount grill mounting options.  
See Magma Catalog or Website for mount selection.

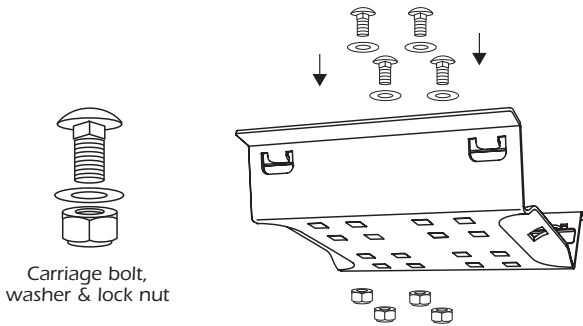

### Single mount through-bolt applications

4 Carriage bolts, washers & lock nuts.

Note: Place washers on carriage bolts as shown.

See Magma website for replacement part numbers and valve applications.

[MagmaProducts.com](http://MagmaProducts.com)

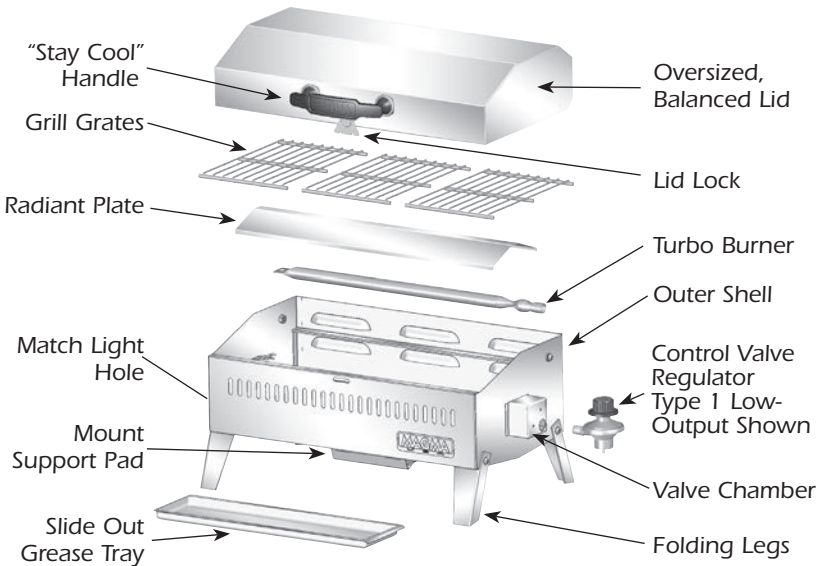

# OPERATING PROCEDURES

## **OPERATE ONLY ON “LOW” WHEN LID IS CLOSED. ALWAYS OPERATE WITH GREASE TRAY IN PLACE.**

WARNING: Do not overheat grill. Magma Grills do not require pre-heating. Stainless Steel loses anti-corrosive characteristics when subjected to extreme heat. Most grilling is done on low temperature with the lid closed. If medium or high heat is required, grill with lid open.

### **LIGHTING INSTRUCTIONS**

- Open lid.
- Place flame up to burner through the match light hole.
- Depress valve and turn counter-clockwise to the “HIGH”.
- Visually confirm ignition.

### **TO REDUCE FLARE-UP**

- Empty and clean grease tray prior to each use.
- Trim excess fats from meat.
- Use non-oil based marinades.
- Reduce heat.
- Use water spray directly on flare-ups.

**NOTE:** Before lighting, lid lock must be positioned not to engage. Open lid and turn lock to locked position.

### **PRACTICAL HINTS:**

**Before lighting your grill, be sure that ...**

- Grill is secure and properly mounted.
- Internal components and grease tray are clean and correctly positioned.
- You have plenty of gas in the canister.
- Gas canister is attached properly and there are no gas leaks.
- Lid lock has been set not to engage.
- You have a water spray bottle handy to cool a hot grill or stop any flare-ups.

### **STOWING TIPS**

- Always disconnect the fuel canister from the valve prior to stowing.
- Stow the valve in a clean, dry area to protect from corrosion to valve.
- Always store propane in a sealed propane storage locker that allows leakage to vent overboard or use **Magma Propane Storage/Locker Tote Bag**.  
Never stow below decks

## DISASSEMBLY & RE-ASSEMBLY

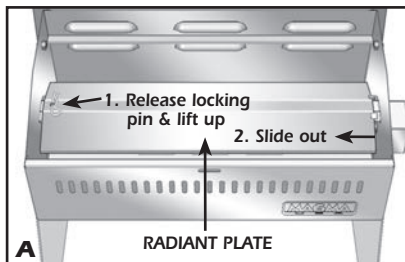

1. To remove radiant plate pull locking pin to release and lift plate up from left side
2. Slide plate assembly from right to left.

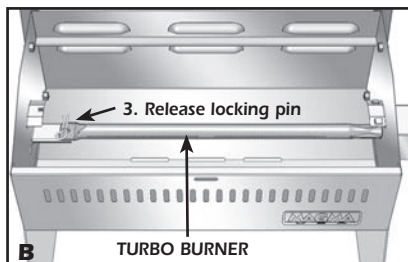

3. To remove burner pull locking pin.

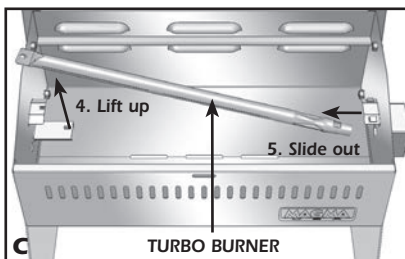

4. Lift burner.
5. Slide from right to left to remove from grill body.

Check burner for grease residue or spider webs that may obstruct gas flow.  
**CAUTION: WHEN REPLACING BURNER, CUT SLOTS IN BURNER MUST FACE DOWN.**

- Inspect burner, remove any obstructions.
- Clean as indicated in Maintenance (page 6).
- To re-assemble, reverse the procedure above.

### Locking grease tray accessible from either side

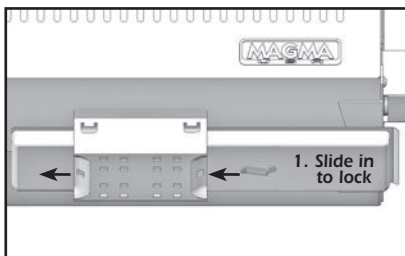

1. Slide Grease Tray into either side of the mounting bracket to lock.

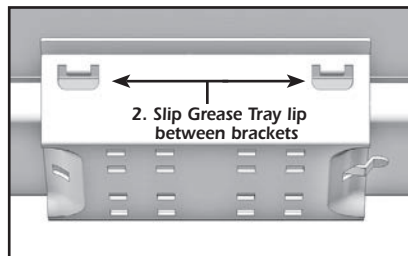

2. Slip Grease Tray lip between both mount brackets

## MAINTENANCE

Stainless steel contrary to popular belief can rust. Most commonly, deposits on surface of the product will trap moisture. It is this moisture that robs stainless steel of oxygen. Oxygen is the element that reacts with stainless steel to form a protective layer of chrome oxide. Robbed of oxygen, this reaction does not take place and “crevice corrosion” or “surface rusting” occurs. To minimize this effect, thoroughly clean your grill with soap and water, rinse with fresh water, and dry. Avoid using stainless steel polishes on grill exterior as most leave a residue that may discolor when grill is heated.

Additionally, stainless steel that is exposed to high heat will change color and texture over time. The “amber” color of grill exterior and internal components is not a failure of the stainless steel and will not affect products operation. When this happens, we recommend using **“Magma Magic” Grill Restorer** to remove the “amber” color and return grill to its original luster. However, prolonged exposure to extreme high heat will cause chromium and nickel to “burn out” of stainless steel. At this point stainless steel will become more susceptible to corrosion and will start to deteriorate. We recommended replacement of internal components as they become seriously deteriorated.

We recommend thoroughly cleaning grill and internal components after each outing. Disassemble interior components and remove all food residue. Use a “Scotch Brite” pad or similar product and “Easy-Off” oven cleaner for cleaning grills interior components, followed by thoroughly washing with soap and water, rinse with fresh water & dry. Thoroughly rinse the area between the interior heat shield and the front surface of the grill. **AVOID CONTACT OF OVEN CLEANER WITH SKIN, CONTROL VALVE, AND BOAT SURFACE. CAUTION: DO NOT USE ANY TYPE OF ABRASIVE PAD ON EXTERIOR MIRROR FINISH AS IT WILL SCRATCH SURFACE, USE ONLY A SOFT CLOTH.** We recommend covering grill between uses. Grill covers are available at Magma retailers or directly from Magma. See our website, **MagmaProducts.com**

**Grill Grates** - Clean with brass wire brush while grill is warm. Use Oven & Grill cleaner for burnt-on residue. Wash with soapy water and dry prior to storage.

**Control Valve** - All valves are set and tested at our factory. Do not attempt to adjust or disassemble the valve in any way. Call Magma if you suspect it is not adjusted properly. Clean valve with a cloth and remove any debris obstructing the orifice.

**Repair/Replacement Parts** - All replacement parts are readily available at your Magma Retailers or directly from Magma. For a complete list of replacement parts visit our website **MagmaProducts.com**

## USING GRILL WITH ON-BOARD LPG (PROPANE) SYSTEMS

- Magma on-board LPG (propane) valves and hose kit allow Magma grills to be installed to an existing on-board, pre-regulated low pressure LPG (propane) system.
- Use only **Magma Type 3 Low Pressure LPG (Propane) Control Valves**. Visit our website at **MagmaProducts.com** to view valve application guide.
- North America use **Magma A10-225 LPG Hose Kit** in conjunction with **Type 3 Valve**. Outside North America see your local dealer for proper hose and fittings.
- Primary shutoff valve (**supplied with A10-225 hose kit**) must be used at point of connection to allow shutoff of gas supply leading to grill.

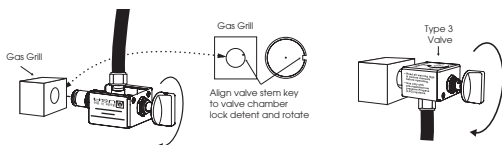

Install valve as shown in diagram above. Even though valve may seem loose or not snug-fitting it will function properly and is safe for use.

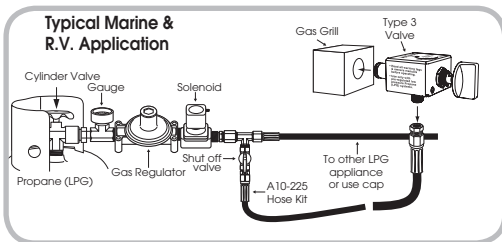

## USING GRILL WITH ON-BOARD CNG (NATURAL GAS) SYSTEMS

- Magma on-board CNG (natural gas) valves allow Magma grills to be installed to an existing on-board, pre-regulated low pressure CNG (natural gas) system.
- Use only Magma Type 4 Low Pressure CNG (natural gas) control valves. Visit our website at [MagmaProducts.com](http://MagmaProducts.com) to view valve application guide. See your local dealer for proper hose and fittings.

## TROUBLE SHOOTING GUIDE

<b>Problem</b>	<b>Possible Cause</b>	<b>Possible Solution</b>
<b>Burner will not light with match</b>	No gas flow  Obstructed gas flow	Check fuel level, replace canister or refill cylinder  Clean burner and valve orifice. Remove debris/spider webs
<b>Flare-up</b>	Excessive cooking temperature  Grease and/or residue build-up Excessive fat in meats  Excessive oils in marinades	Operate only on low when lid is closed Reduce flame level Leave lid open Use water spray to cool  Clean components  Trim fat from cuts of meat before grilling  Use non-oil based marinades
<b>Yellow sooty flame</b>	Obstructed gas flow	Clean burner and valve orifice. Remove debris/spider webs
<b>Blow-out</b>	Flame too low Wind directly on burner Obstructed gas flow	Increase flame  Block wind when opening lid  Clean burner and valve orifice. Remove debris/spider webs
<b>Hot Spots</b>	Grill not level Grease or residue build-up Excessive fat in meats  Excessive oil in marinades	Level Grill  Clean components  Trim fat from cuts of meat before grilling  Use non-oil based marinades

# CONTENTS

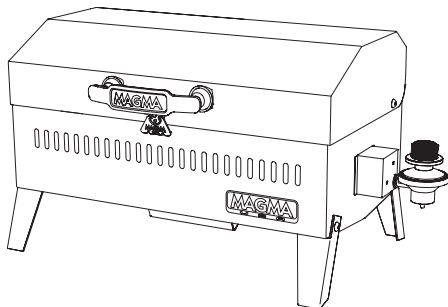

x 4



x 4



x 4

Pack of (4) 1/4"-20 x 5/8" carriage bolts, washers and lock nuts for single mount applications.

## LIMITED WARRANTY

Magma Products, Inc. guarantees this product to be free from defects in materials or workmanship to the original consumer. This guarantee is for the periods herein specified when used under normal and reasonable conditions, one (1) year from the date of original purchase. This warranty does not include the cost of property damage or any inconvenience due to the failure of the product. Nor does it cover damage due to misuse, abuse, accident, or damage resulting from transportation of the product. Nor does it include damage resulting from the commercial use of this product. Nor does it include, on stainless steel products, "Surface Rust"; Excessive Corrosion due to exposure to salt water; or Discoloration or Corrosion caused by exposure to excessive heat or failure to properly clean and care for the stainless steel surfaces. If the product fails to operate due to a defect in materials or workmanship during the warranty period, the defective part will be repaired or replaced at Magma's option. If you wish to obtain performance under this limited warranty, you should contact Magma's Customer Service Department via telephone at (562) 627-0500, or via e-mail at mail@MagmaProducts.com, or via U.S. Postal Service mail at "Magma Products, Inc., Attention Customer Service, 3940 Pixie Ave. Lakewood, CA, 90712". The defective part, along with proof of purchase, must be returned postage prepaid to Magma Products, Inc. We suggest that you keep your purchase receipt as we may require reasonable proof of purchase.

In the state of California only, if refinishing or replacement of the product is not commercially practicable, the retailer selling the product, or Magma Products, Inc., will refund the purchase price paid for the product, less the amount directly attributable to use by the original consumer prior to the discovery of the nonconformity. In addition, in the state of California only, you may take the product to the retail establishment from which it was purchased or to any retail establishment selling this product in order to obtain performance under this warranty. All implied warranties, including the implied warranties of merchantability and fitness for a particular purpose, are limited in duration to the express warranty periods specified herein for the parts described herein. Some states do not allow limitations on how long an implied warranty lasts, so the above limitation may not apply to you. Neither Magma dealers, nor the retail establishment selling this product has any authority to make any warranties or to promise remedies in addition to or inconsistent with those stated above. Magma's maximum liability shall not exceed the purchase price of the product paid by the original consumer. Some states do not allow the exclusion or limitation of incidental or consequential damages, so the above limitation or exclusions may not apply to you. The warranty gives you specific legal rights and you may also have other rights which vary from state to state.

MAGMA and the Magma logo are registered trademarks of Magma Products, Inc.  
Cabo is a trademark of Magma Products, Inc.  
Patent pending.

CALIFORNIA PROPOSITION 65 – WARNING – The burning of gas cooking fuel generates some by-products, which are on the list of substances, which are known by the State of California to cause cancer or reproductive harm. California law requires businesses to warn customers of potential exposure to such substances. To minimize exposure to these substances, always operate this unit according to the use and care manual, ensuring you provide good ventilation when cooking with gas.

# MAGMA<sup>®</sup>

U S A

MAGMA PRODUCTS, INC.  
3940 Pixie Ave. • Lakewood, CA 90712  
Tel: (562) 627-0500 • mail@MagmaProducts.com  
MagmaProducts.com



**ADDENDUM FOR GAS GRILL MODEL  
A10-703AU-3  
SOLD IN AUSTRALIA**

**CAUTION:** Accessible parts may be very hot. Keep young children away. **ONLY USE IN WELL-VENTILATED AREAS.** • CARBON MONOXIDE HAZARD-THIS APPLIANCE CAN PRODUCE CARBON MONOXIDE WHICH HAS NO ODOUR. DO NOT USE IN ENCLOSED AREAS, (FOR EXAMPLE: CAR, TENT, CARAVAN, MOBILE HOME) MAY CAUSE DEATH. This appliance shall only be used in an above ground, open air situation with natural ventilation, without stagnant areas, where gas leakage and products of combustion are rapidly dispersed by wind and natural convection.

Any enclosure in which the appliance is used shall comply with one of the following:

(A) An enclosure with walls on all sides, but with no overhead cover.

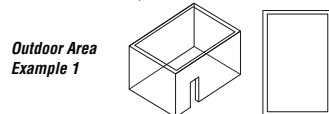

(B) Within a partial enclosure that includes an overhead cover and no more than two walls.

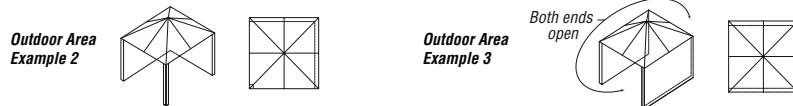

(C) Within a partial enclosure that includes an overhead cover and more than two walls, the following shall apply:

- (1) At least 25% of the total wall area is completely open.
- (2) 30% or more in total of the remaining wall side, back and front wall areas is open and unrestricted.
- (3) In the case of balconies, 20% or more of the total wall area shall remain open and unrestricted.

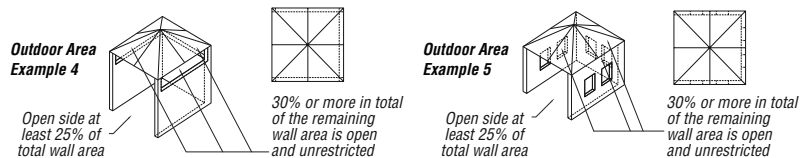

- Use appliance only in horizontal position.
- This appliance must only be serviced by an authorized person.
- Do not use this appliance if it has damaged or worn seals.
- Do not move this appliance during operation.

**FUEL CONTAINERS:** Change gas containers in well-ventilated areas, preferably outside, away from people & sources of ignition; such as naked flames, pilot flames, electric heaters/equipment. Do not use appliance if it is leaking, damaged, or not working properly. Check that burners are extinguished before removing gas container. To check if gas cylinder is empty, remove regulator/valve and shake listening for liquid in cylinder; if no liquid sounds are heard, cylinder is empty.

**GAS LEAKS: NEVER CHECK FOR GAS LEAKS WITH A FLAME!** Check for gas leaks by applying a soapy solution to connections. If bubbles appear, turn off appliance and repair leaks as necessary.

**Australia** - Use Propane Gas Only.  
**New Zealand** - Use Universal LPG Gas Only.

Over

Front

**HOW TO ISOLATE GAS SUPPLY IN THE EVENT OF A LEAK (smell of gas):**

**Cylinders:** If there is a leak on your appliance (smell of gas), immediately attempt to turn off cylinder valve. Turn off appliance control valve. Remove appliance to a well-ventilated location away from any ignition source.

**STORAGE: NEVER LEAVE GAS CYLINDERS CONNECTED WHEN NOT IN USE!**

**Cylinders:** When you have finished using this appliance, turn gas cylinder off; wait for the flame to go out and turn the appliance control valve off. Remove appliance control valve from appliance and store control valve in a dry, non-corrosive environment. • Store fuel containers outdoors, in a well ventilated area, out of reach of children, never below decks on boats. (Any indoor storage shall comply with Section 2 Minor storage and usage of **AS/NZS 1596**).

**HOSES:** Only use the hose assembly intended for use with this appliance for connection to the cylinder. – DO NOT USE ADAPTORS. (RECA #719 AGA 3735 Regulator) Connections must be spanner tight per AGA requirements. Make sure gas hose is in good condition and avoid twisting or kinking.

**PACKING MATERIALS: BEFORE INSTALLATION OR USE!**

- Open package containing grill and components, remove all contents.

**Package contents:**

- Grill body
- Valve - Located in end cap supports
- Product owner's manual
- Remove grill from plastic bag.
- All necessary assembly instructions are detailed in the provided owner's manual.

- Orifice size for models A10-703NZ-3 is 0.79 mm.
- The nominal gas consumption for models A10-703NZ-3 is 8.3 MJ/H.

**On Board Pre-Regulated Low Pressure Propane Systems (LPG)**

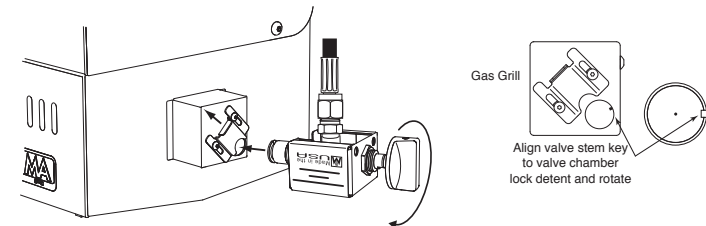

**Whitworth's Marine and Leisure, Brookvale, Sydney will fit the Gas Assembly.**  
**The complete configuration will include:**

- An AGA approved Recca Regulator with a POL fitting and a 1.8m hose with a 1/4" BSP connection
- A MAGMA Low Pressure Valve fitted with a 1/4" NPT to 1/4" BSP Adaptor fitted in the MAGMA factory

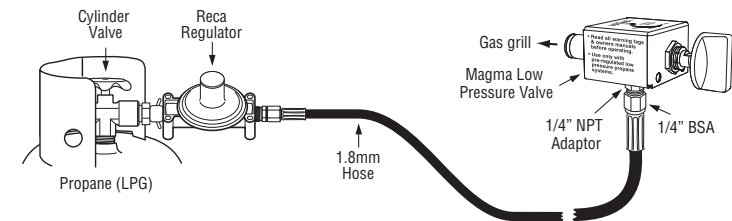

83-703NZ 0615

Back