

T10-640 "Dual" Extended Side/Bulkhead Mount

Mount Weight 4.00 lb.
(1.8 kg)

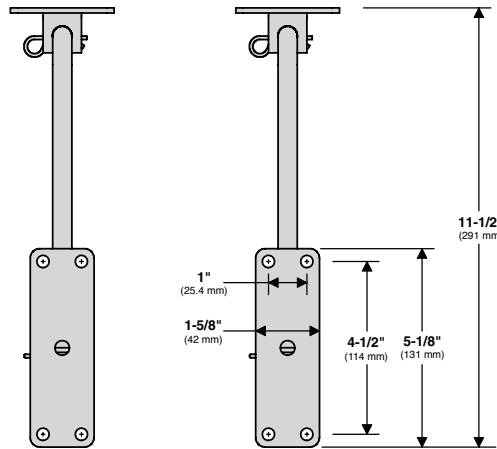

MAGMA PRODUCTS, INC.
3940 Pixie Ave. • Lakewood, CA 90712
Tel: (562) 627-0500
MagmaProducts.com
Mail@MagmaProducts.com

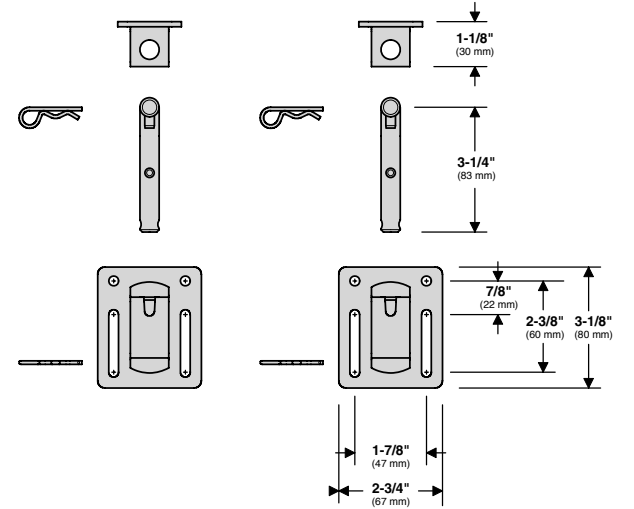
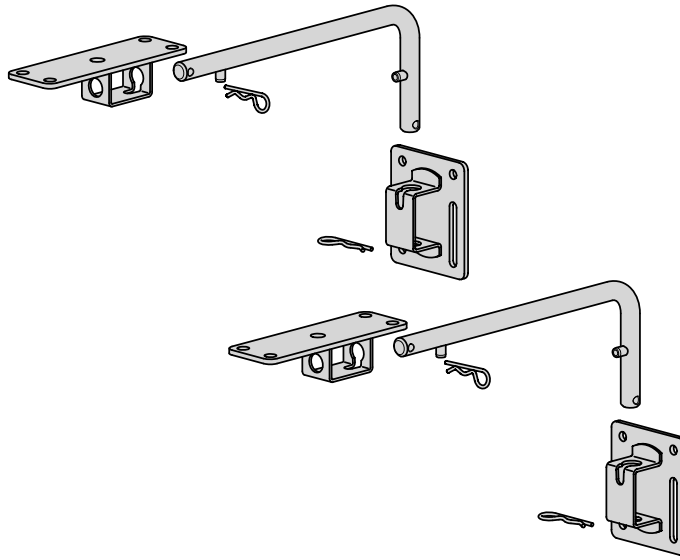

TOP VIEW

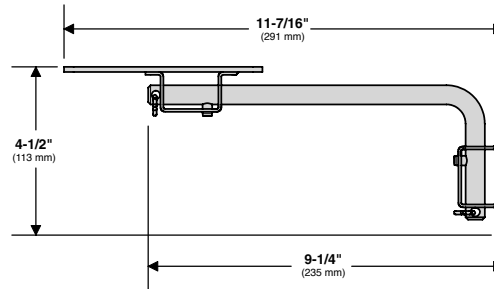

SIDE VIEW

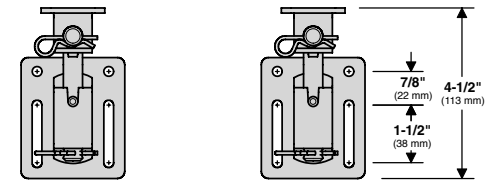

FRONT VIEW