	PACCOR Polska Sp. z o. o. Skierniewice Branch Replaces specification no. <i>n/a</i> From: <i>n/a</i> Due to: name & logo change	Version 0 Revision A Date: 12-02-2019 Page 1 of 2
	Article: transparent PET lid with cross-cut 95mm (800pcs) Specification no. transparent LCC95 Ø98,6xH9,4	UPC: 5907739614179 Food contact: cold beverages
Code: E400211 Prepared by: GS	Production Supervisor: Dept. Super.	CE mark: no
Checked by: Dept. Super. Attachments:	Article drawing: Flat lid 95 with cross.pdf ;	

Article photo:

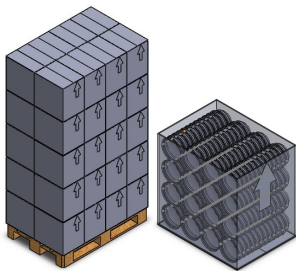

Box packaging top view:



Box inner size:

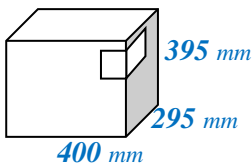

Palletizing:

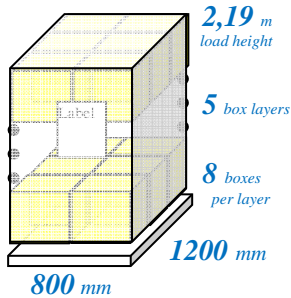

Articles in a pile: **50**
 Piles in a box: **16**
 Articles in a box: **800**
 Box inner size: **400x295x395**
 Box load gross: **2,9 kg**
 Boxes per pallet: **40**
 Articles per pallet: **32000**
 Pallet height: **2,19 m**

Pallet type: **G300001-EURO**
 Pallets per truck: **33**
 FTL: **1056000**

Packaging conditions:

- Wooden pallets, clean, dry
- On pallet top: **film**
- Box liner: **LDPE G380305 półprzezroczysty LD 500/0,022 22µ**
- Labels per pallet sides: **2**
- Corner box label: **yes**
- Customer label: **no**
- Box: **cardboard G300010 - 620551**

- Remarks: **No separation between box layers - Absorption pads: no - Stacking: A-A - Sleeve label: yes**

I. General arrangement

PACCOR Polska Sp. z o. o. will deliver the article **PET lid with cross-cut 95mm (800pcs)** according to and within the limits of this article specification. Supplier food contact safety declaration will follow.

Basic article characteristics are outlined in the attached article drawing: "**Flat lid 95 with cross.pdf**". No modifications to the article characteristics listed below are allowed, unless agreed to by both parties and expressed in writing, and signed/autographed. ID as per box no. and production date (label).

II. Raw material specification

Compounds	Basic composition	Alternative
Name	rPET 80%	50% R-PET / 50% VIRGIN
Percentage		
Name	AB both sides Formasil	0%
Percentage	1%	
Name	0%	
Percentage		

III. Sheet specification

Parameter	Value	Tolerance
Thickness	0,24 mm	±0,02 mm
Width	670,0 mm	+2/-2 mm
Colour*	transparent	BWTC
Layers	E170114 FOLIA PET 0,24 x 770 transp. RDK wieczko Dim.95mm	

IV. Basic article characteristics

Parameter	Value	Tolerance
Length (or Ø)	98,6 mm	±0,5 mm
Width (or Ø)	,0 mm	mm
Height	9,4 mm	±0,5 mm
Stacking distance	4,80 mm	±0,2 mm
Weight	3, g	-0,1/0,2 g
Capacity nominal / brimful	/ ml	ml
Reference*:	PET lid with cross-cut 95mm (800pcs)	

*B – black, W – white, T – transparent, C – any colour

V. Microbiology tests

Once a month a comparative microbiology test of factory air is run against external air, with air circling articles examination in material groups (rotating) against internal normative levels. Records are kept for a minimum of three years and their values are available to the buyer.

VI. Delivery & Storage:

Deliveries according to transport regulations, details on the left. Store in dry, clean, shaded areas, away from heat sources, 10-40°C, RH<85%. Articles good to use within a year from production date, if properly stored.

VII. Other

In case of change in article use or processing the recipient is obligated to contact the supplier with pertaining details as soon as possible.

VIII. Signed approval

H&Q Manager	Buyer Representative:	
Monika Mikulska		
Date: 12-02-2019	Date: 12-02-2019	Date:

	PACCOR Polska Sp. z o. o.		Version 0
	Skierniewice Branch		Revision A
	Replaces specification no. n/a From: n/a Due to: name & logo change		Date: 12-02-2019
			Page 2 of 2
Code: E400211		Article: transparent PET lid with cross-cut 95mm (800pcs) Specification no. transparent LCC95 Ø98,6xH9,4	UPC: 5907739614179 Food contact: cold beverages
Prepared by: GS			CE mark: no
Checked by: Dept. Super.		Production Supervisor: Dept. Super.	
Attachments:		Article drawing: Flat lid 95 with cross.pdf;	



Professional Food Servicepcs / szt.

Wieczko płaskie z krzyżykiem • Lid flat with cross 95mm

E400211



5 907739 641236







A

B

C

D

E

F

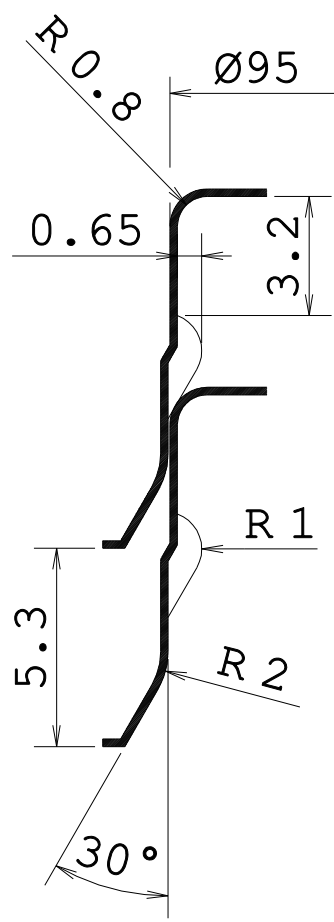
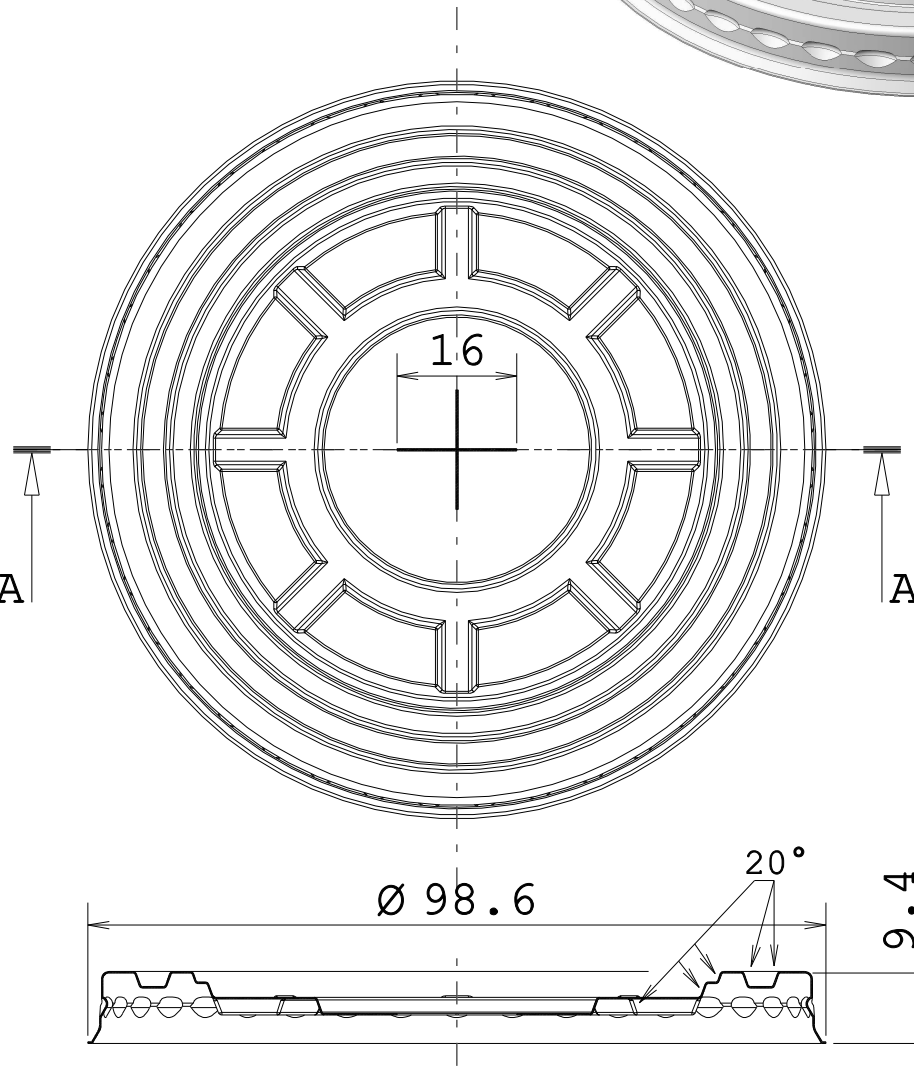
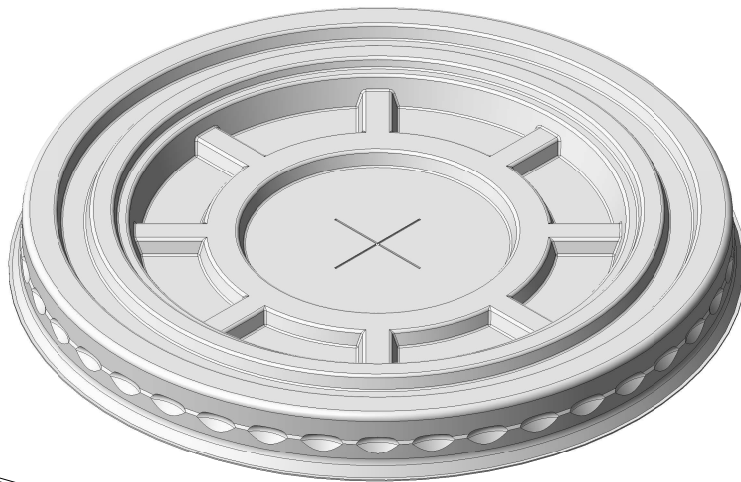

Sect. A-A

Stacking (5:1)

100	-	60091838				
PART:	QUANT.	ASSY/ORDER:	DESCRIPTION OF REVISION:	DRAWN:	DATE:	REV.

MATERIAL: PET - 200mu	GENERAL ROUGHNESS ra IN um ISO 1302	FORM AND POSITION TOLERANCES ISO R 1101
TREATMENT: -	ALL RIGHTS STRICTLY RESERVED. REPRODUCTION OR ISSUE TO THIRD PARTIES IN ANY FORM WHATEVER IS NOT PERMITTED WITHOUT WRITTEN AUTHORITY FROM THE PROPRIETOR	GENERAL TOLERANCES LINEAR: ± 0.2 ANGLE: ±

DATE : 13-12-2012	DESCRIPTION: Lid Ø95 with cross-cut	SIZE: A4
DRAWN: E.Ubbink	Productdrawing	SHEET 01 of 1



SCALE: 1:1	AMERICAN PROJECTION DIMENSIONS IN MM	DRAWING NO. 105160091838100	TYPE: prd	REV.
---------------	---	--------------------------------	-----------	------