



BCS Motor mowers, BCS 2-wheel tractors

660 HY WS PS



A60007 - 660 HY WS PS.....	5
A.01.02.A0028_00 - ACCESSORIES MACHINE / ENGINE.....	9
A.01.02.A0028_01 - ACCESSORIES MACHINE / ENGINE.....	11
A.01.02.A0028_02 - ACCESSORIES MACHINE / ENGINE.....	13
B.01.01.A0001_03 - POWERSAFE CLUCH CONTROL.....	15
B.01.01.A0001_04 - POWERSAFE CLUCH CONTROL.....	17
B.01.01.A0001_05 - POWERSAFE CLUCH CONTROL.....	19
C01_0_116836 - CYLINDER AND POWERSAFE CLUTCH.....	21
C01_1_125029 - CYLINDER AND POWERSAFE CLUTCH.....	23
C.01.01.A0001_02 - CYLINDER AND POWERSAFE CLUTCH.....	25
D.01.02.A0028_00 - POWERSAFE FILTER AND UNIT.....	27
D.01.02.A0028_01 - POWERSAFE FILTER AND UNIT.....	29
D.01.02.A0028_02 - POWERSAFE FILTER AND UNIT.....	31
E.01.02.A0028_00 - POWERSAFE CLUTCH HUB.....	33
E.01.02.A0028_01 - POWERSAFE CLUTCH HUB.....	35
E.01.02.A0028_02 - POWERSAFE CLUTCH HUB.....	37
F.01.02.A0028_00 - ENGINE FLANGES.....	39
F.01.02.A0028_01 - ENGINE FLANGES.....	41
G.01.02.A0028_00 - GEARBOX.....	43
H.01.02.A0028_00 - GEAR SHAFT CLUTCH.....	45
G.01.02.A0028_01 - GEARBOX.....	47
G.01.02.A0037_02 - GEARBOX.....	49
H.01.02.A0028_01 - GEAR SHAFT CLUTCH.....	51
H.01.02.A0028_02 - GEAR SHAFT CLUTCH.....	53
H.02.02.A0028_00 - REFERENCE GEAR / SHAFT CLUTCH.....	55
H.01.02.A0028_03 - GEAR SHAFT CLUTCH.....	57
H.02.02.A0028_01 - REFERENCE GEAR / SHAFT CLUTCH.....	59
H.02.02.A0028_02 - REFERENCE GEAR / SHAFT CLUTCH.....	61
H.02.02.A0028_03 - REFERENCE GEAR / SHAFT CLUTCH.....	63



H.03.02.A0028_00 - AUTOMATIC BRAKE.....	65
H.04.02.A0028_00 - PUMP ASSEMBLY.....	67
H.04.02.A0028_01 - PUMP ASSEMBLY.....	69
H.04.02.A0028_02 - PUMP ASSEMBLY.....	71
H.05.02.A0028_00 - PUMP CONTROL.....	73
H.05.02.A0028_01 - PUMP CONTROL.....	75
H.05.02.A0028_02 - PUMP CONTROL.....	77
I.01.02.A0028_00 - CLUTCH STEERING.....	79
I.01.02.A0028_01 - CLUTCH STEERING.....	82
I.01.02.A0028_02 - CLUTCH STEERING.....	85
I.01.02.A0028_03 - CLUTCH STEERING.....	88
I.01.02.A0028_04 - CLUTCH STEERING.....	91
I.02.02.A0028_00 - WHEEL AXLE.....	94
I.02.02.A0028_01 - WHEEL AXLE.....	96
I.02.02.A0028_02 - WHEEL AXLE.....	98
I.03.02.A0028_00 - DRIVE AXLE WHEELS.....	100
I.03.02.A0028_01 - DRIVE AXLE WHEELS.....	102
I.03.02.A0028_02 - DRIVE AXLE WHEELS.....	104
J.01.02.A0028_00 - STEERING COLUMN.....	106
J.01.02.A0028_01 - STEERING COLUMN.....	108
J.01.02.A0028_02 - STEERING COLUMN.....	110
J.01.02.A0028_03 - STEERING COLUMN.....	112
K.01.02.A0028_00 - CONTROL LEVERS.....	114
K.01.02.A0028_01 - CONTROL LEVERS.....	116
K.01.02.A0028_02 - CONTROL LEVERS.....	118
L.01.02.A0028_00 - HANDLEBAR CONTROLS.....	120
L.01.02.A0028_01 - HANDLEBAR CONTROLS.....	122
L.01.02.A0028_02 - HANDLEBAR CONTROLS.....	124
L.01.02.A0028_03 - HANDLEBAR CONTROLS.....	127
L.01.02.A0028_04 - HANDLEBAR CONTROLS.....	130



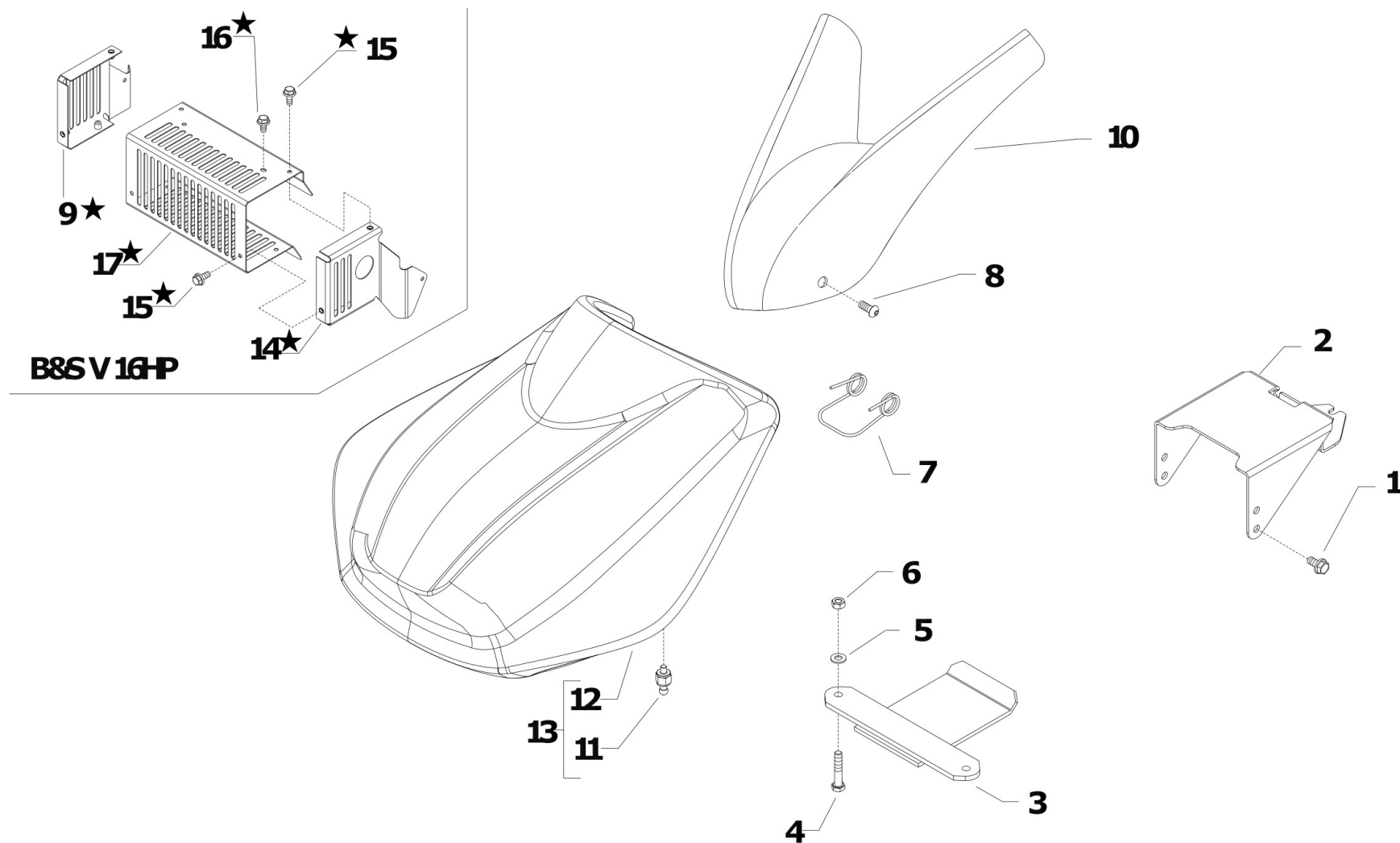

i = info - stop 2 sec. ★ = new part



BCS Motor mowers, BCS 2-wheel tractors - 660 HY WS PS

A.01.02.A0028_01 - ACCESSORIES MACHINE / ENGINE

Pos.	Id	Q.ty	Description	Note
1	31112166		SCREW TE C/F M8X25 DIN 6921 8G	
2	56156528		TUNNEL	
3	56156119N		SHIELD	GX390 - B&S V 16 HP
3	59056111		SHIELD	L100
4	31112154		SCREW TE M8X40 UNI 5739 8G	L100
4	31112169		SCREW TE C/F M8X40 DIN 6921	GX390 - B&S V 16 HP
5	31411084		WASHER 8,4x17	L100
6	31241080		HEXAGON SELFLOCK NUT M8	L100
6	31241084		SELFLOCK NUT M8 6S	GX390 - B&S V 16 HP
7	58056889		RETAINING SPRING	
8	31121005		SCREW TBCEI FLANG. M6X25	
9	590C0413		GUARD	
10	590C0375		GUARD	
11	561C0373		CAP	
12	580C0370		CARENATURA CENTRALE IDRO	
13	590C0369		GUARD	
14	590C0411		GUARD	B&S V 16 HP
15	31112084		SCREW TE C/F M6X14 DIN 6921 8G	B&S V 16 HP
16	31112083		SCREW M6X12	B&S V 16 HP
17	561C0410		PROTEZ.CENTRAL.MARMITTA VT grz	B&S V 16 HP



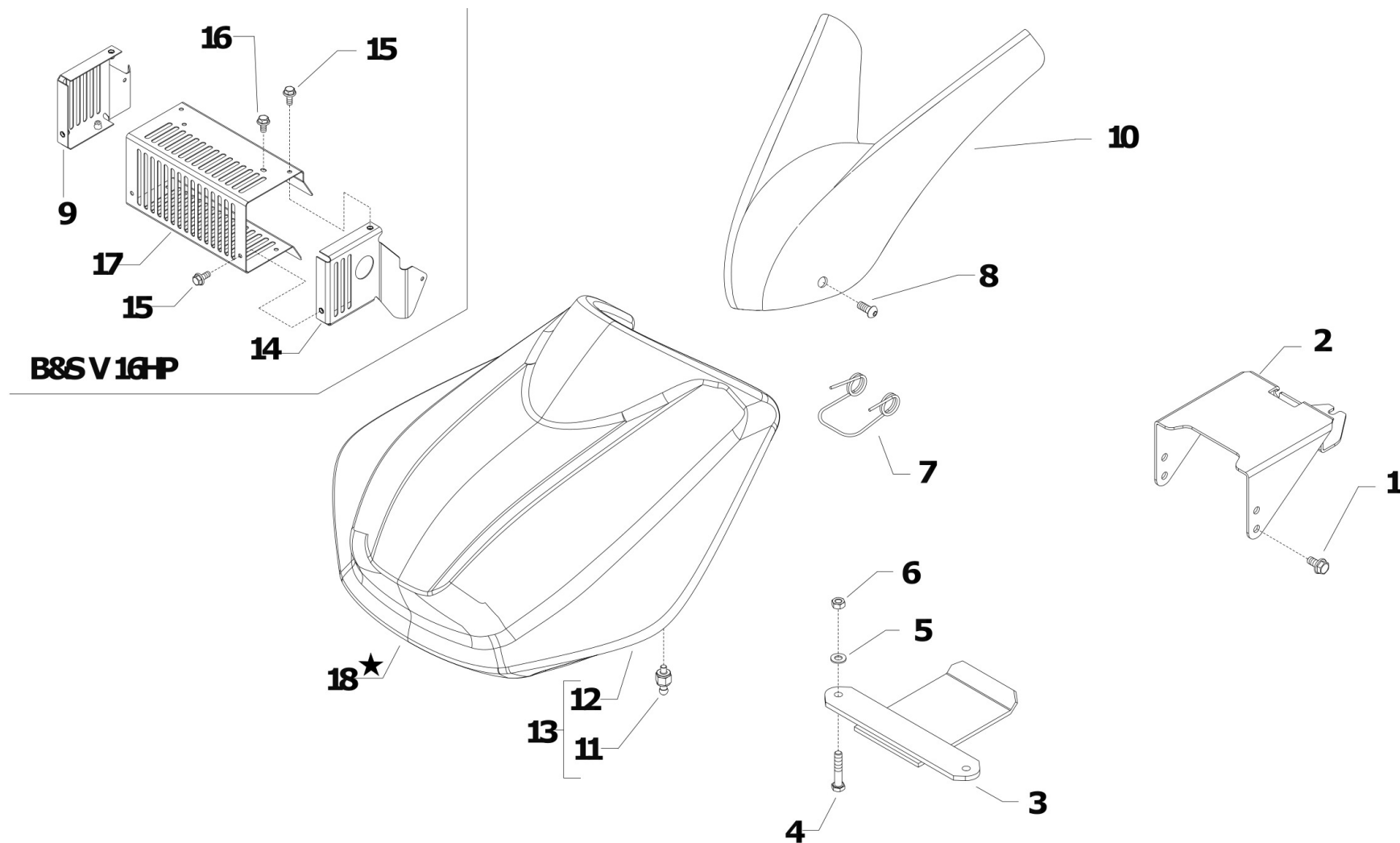

i = info - stop 2 sec. ★ = new part



BCS Motor mowers, BCS 2-wheel tractors - 660 HY WS PS

A.01.02.A0028_02 - ACCESSORIES MACHINE / ENGINE

Pos.	Id	Q.ty	Description	Note
1	31112166		SCREW TE C/F M8X25 DIN 6921 8G	
2	56156528		TUNNEL	
3	56156119N		SHIELD	
3	59056111		SHIELD	
4	31112154		SCREW TE M8X40 UNI 5739 8G	
4	31112169		SCREW TE C/F M8X40 DIN 6921	
5	31411084		WASHER 8,4x17	
6	31241080		HEXAGON SELFLOCK NUT M8	
6	31241084		SELFLOCK NUT M8 6S	
7	58056889		RETAINING SPRING	
8	31121005		SCREW TBCEI FLANG. M6X25	
9	590C0413		GUARD	
10	590C0375		GUARD	
11	561C0373		CAP	
12	580C0370		CARENATURA CENTRALE IDRO	
13	590C0369		GUARD	
14	590C0411		GUARD	
15	31112084		SCREW TE C/F M6X14 DIN 6921 8G	
16	31112083		SCREW M6X12	
17	561C0410		PROTEZ.CENTRAL.MARMITTA VT grz	
18	55257500		BODYWORK	660L HYWS



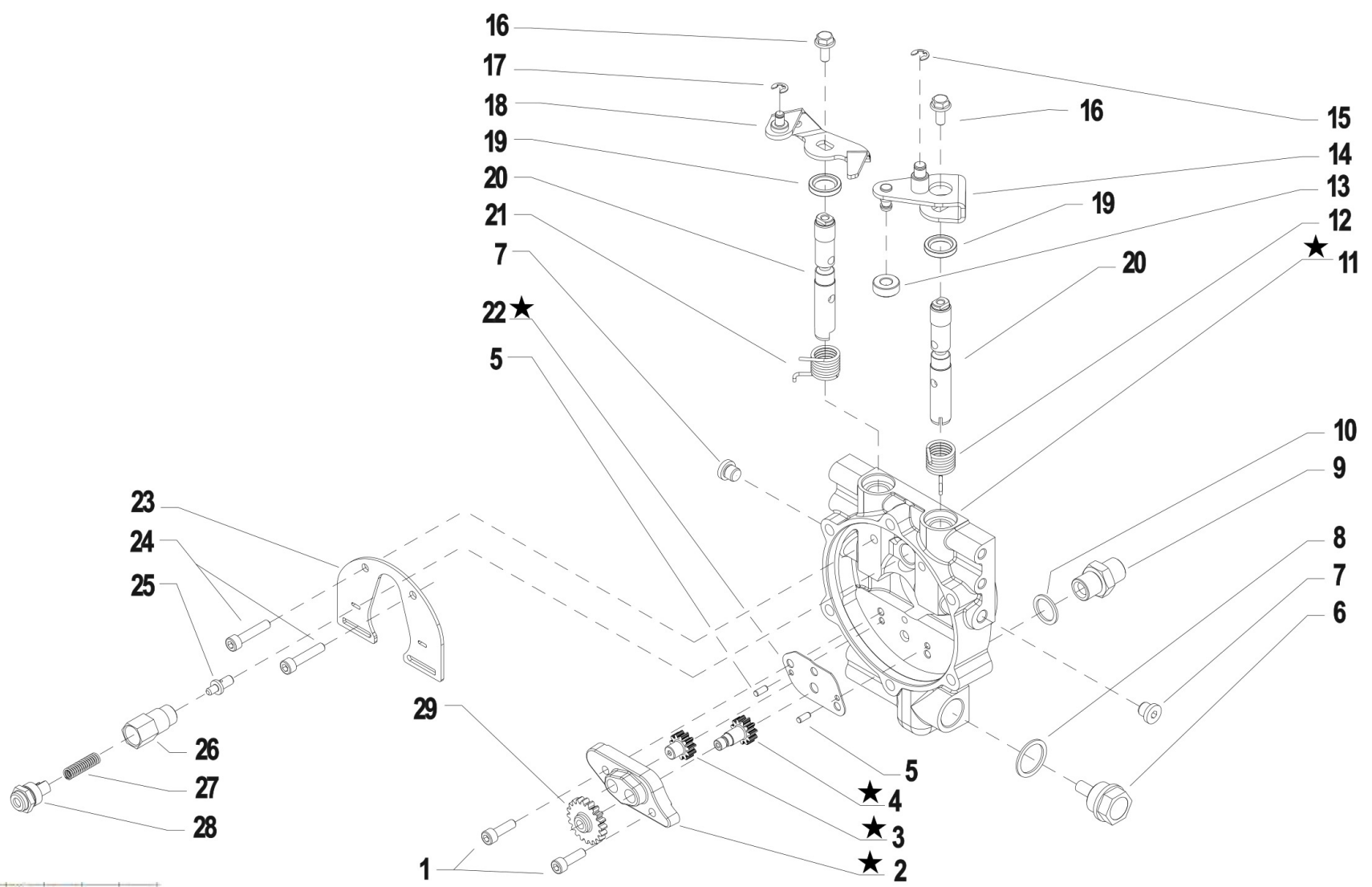

i = info - stop 2 sec. ★ = new part



BCS Motor mowers, BCS 2-wheel tractors - 660 HY WS PS

B.01.01.A0001_05 - POWERSAFE CLUCH CONTROL

Pos.	Id	Q.ty	Description	Note
1	31152063		SCREW TCEI M6X20 UNI 5931	
2	56356364		PUMP COVER PS/14	REPLACE 51156214 + 52456217 + 52456223 + 56356661 + 59256200
3	52456371		PUMP GEAR PS/14	REPLACE 51156214 + 52456217 + 52456223 + 56356661 + 59256200
4	52456372		PUMP GEAR	REPLACE 51156214 + 52456217 + 52456223 + 56356661 + 59256200
5	34221040		CYLINDRICAL PLUG	
6	58170021		PLUG	
7	580C0041		PLUG	
8	F0844273090		GASKET 22X28X1,5 CU 99,5	
9	30000197		NIPPLE	
10	31480184		COPPER WASHER 16,7x22/1,5	
11	59256745		POWERSAFE CLUTCH FLANGE	REPLACE 51156214 + 52456217 + 52456223 + 56356661 + 59256200
12	58056222		SPRING	
13	55256228		ROLLER	
14	59056225Z		CLUTCH LEVER	
15	35211060		SEEGER RING E 6 UNI 7434	
16	31112084		SCREW TE C/F M6X14 DIN 6921 8G	
17	35211050		SEEGER RING E 5 UNI 7434	
18	59056748Z		COMPLETE STOP LEVER PS GALV.	
19	38211400		OIL SEAL 14X22X4	
20	52456220		DISTRIBUTOR	
21	58056221		SPRING	
22	56356747		PUMP RECEPTOR PS/14	REPLACE 51156214 + 52456217 + 52456223 + 56356661 + 59256200
23	56156224		SHIELD	
24	31152060		SCREW TCEI M6X30 UNI 5931	
25	56456657		VALVE	
26	56156658		VALVE INSERT/INLET	
27	58056683		SPRING	Replaces 58056192 from serial number 883609
28	56356242		PLUG	
29	52456235		PUMP GEAR	



BCS Motor mowers, BCS 2-wheel tractors - 660 HY WS PS

B.01.01.A0001_05 - POWERSAFE CLUCH CONTROL

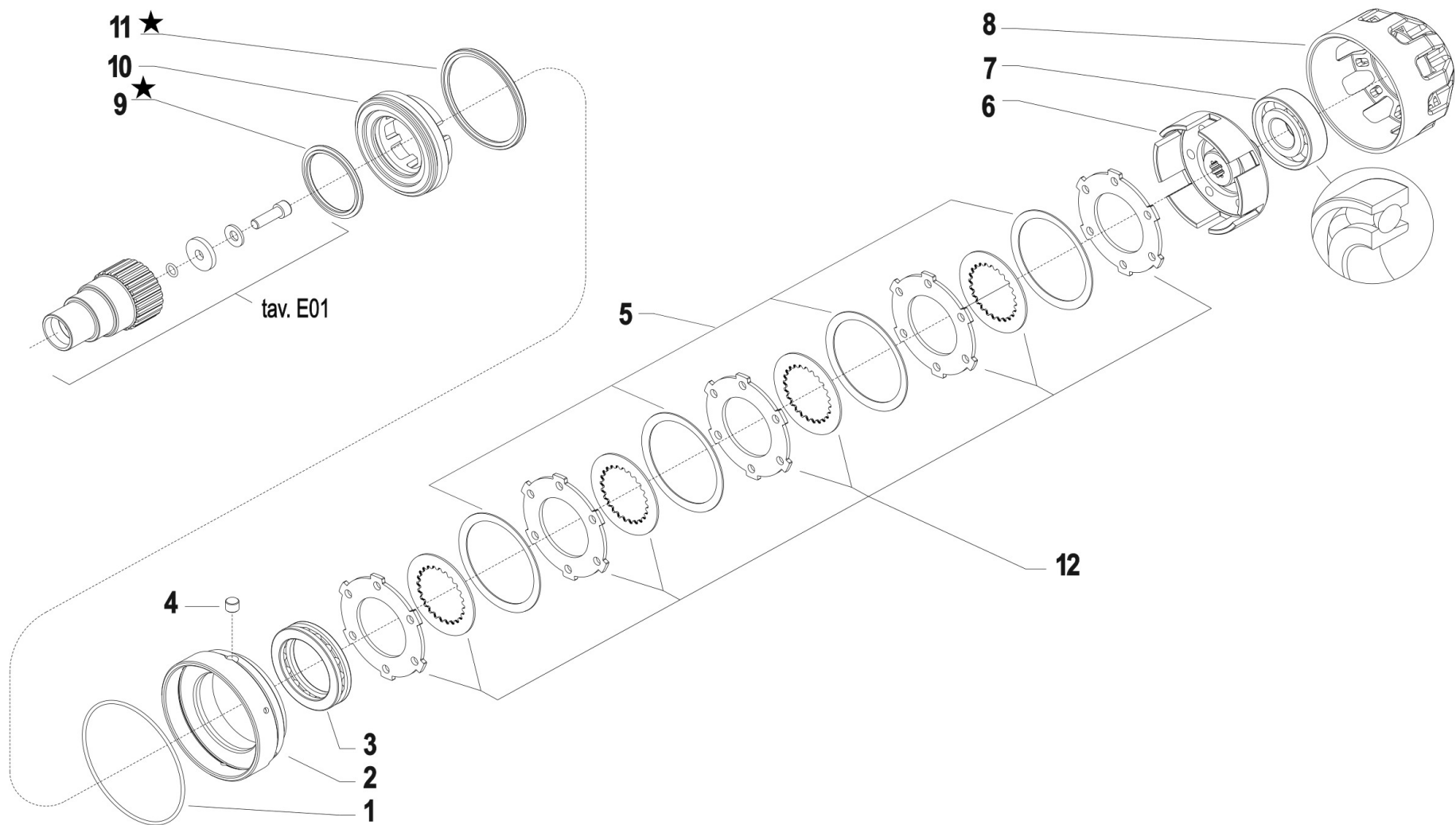

i = info - stop 2 sec. ★ = new part



BCS Motor mowers, BCS 2-wheel tractors - 660 HY WS PS

C.01.01.A0001_02 - CYLINDER AND POWERSAFE CLUTCH

Pos.	Id	Q.ty	Description	Note
1	38118859		O-RING OR 3375 (94,92X2,62)	
2	56356216		RING	
3	37161500		BEARING 51110 (50X70X14)	
4	56156247		PIN	
5	56556213		SPRING	n. 4
6	52456694		CLUTCH HOUSING	Replaces 56356212 + 56356215 + 52456211
7	37141253		BEARING 7305-BJP OBL 25x62x17	
8	53156210		SUMP	
9	38120501		RING PTFE PRP 01A02-0500-A-32	REPLACE 38120500 + 38140850
10	53156218		PISTON	
11	38140851		RING PTFE PRP02A02-0850-A-32-N	REPLACE 38120500 + 38140850
12	59256693		9 DISC CLUTCH	Replaces 56356212 + 56356215 + 52456211



BCS Motor mowers, BCS 2-wheel tractors - 660 HY WS PS

C.01.01.A0001_02 - CYLINDER AND POWERSAFE CLUTCH

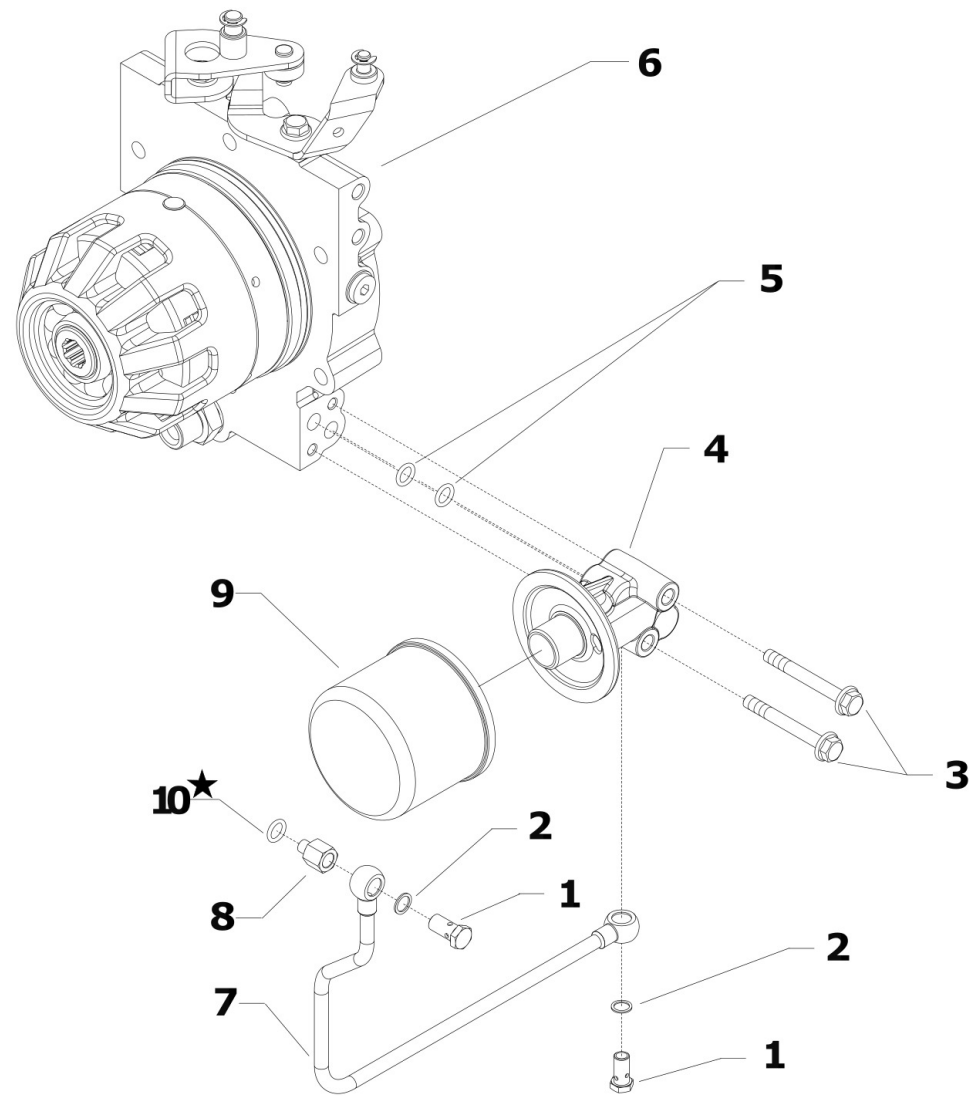

 [Click for info](#)

★ = new part



BCS Motor mowers, BCS 2-wheel tractors - 660 HY WS PS

D.01.02.A0028_02 - POWERSAFE FILTER AND UNIT

Pos.	Id	Q.ty	Description	Note
1	F0843109020		PIPE FITTING	
2	31480184		COPPER WASHER 16,7x22/1,5	
3	31112099		SCREW TE C/F M6X50 DIN 6921 8G	
4	53156659		CONNECTION	
5	38110873		O-RING 108 (8,73X1,78)	
6	59256037		CLUTCH FOR POWERSAFE Q25.4 (3/8)	GX390A
6	59256038		POWERSAFE CLUTCH	L100
6	59256040		GRUPPO FRIZIONE PS Q25,4 VT	B&S VT 16 HP
7	590C0219Z		SUCTION PIPE	
8	581C0225		REDUCTION	
9	580C0268		FILTER	
10	38111078		O-RING 3043 (10,78X2,62)	



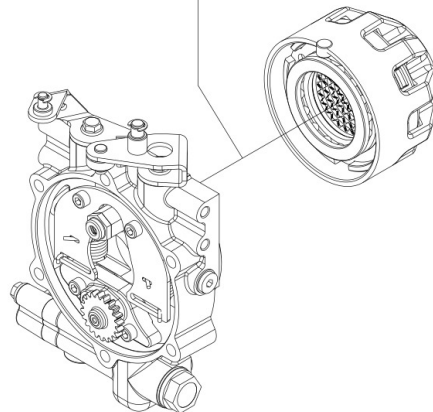
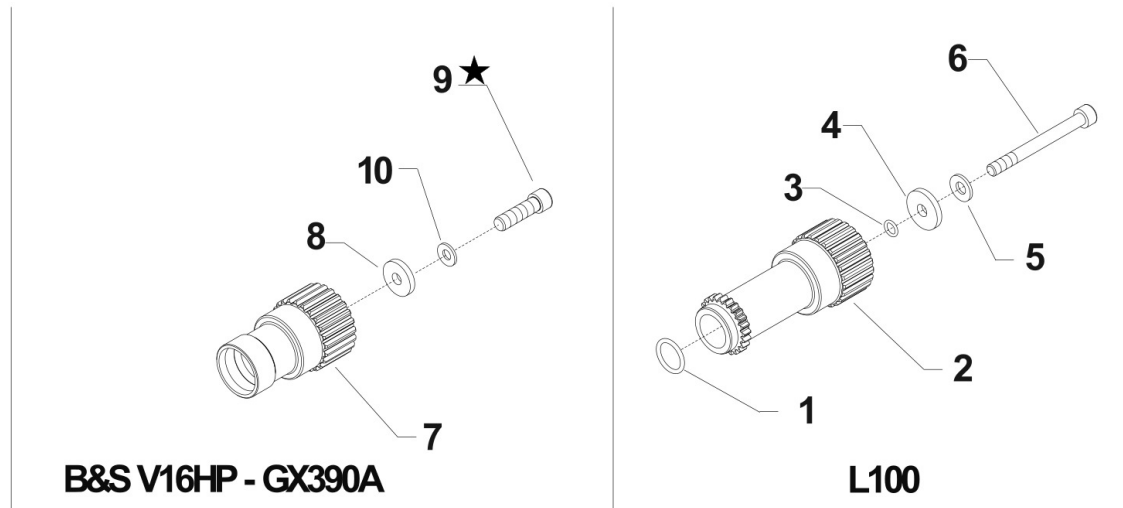

i = info - stop 2 sec. ★ = new part



BCS Motor mowers, BCS 2-wheel tractors - 660 HY WS PS

E.01.02.A0028_02 - POWERSAFE CLUTCH HUB

Pos.	Id	Q.ty	Description	Note
1	38111872		O-RING 3075 (18,72x2,62)	
2	52456245		HUB	
3	38110675		O-RING 106 (6,75X1,78)	
4	56156288Z		SPECIAL WASHER SP.4	
5	31421083		WASHER	
6	31152090		SCREW TCEI M8x80 UNI5931	
7	52456233		HUB Q25	
8	561C0421		WASHER	
9	31100025		SCREW 3/8-24X1 3/4UNF 10K	
9	31100033		SCREW TCCEI 3/8-24 X 1-1/2	REPLACE 31100031
10	31421101		WASHER 10 DIN 679	



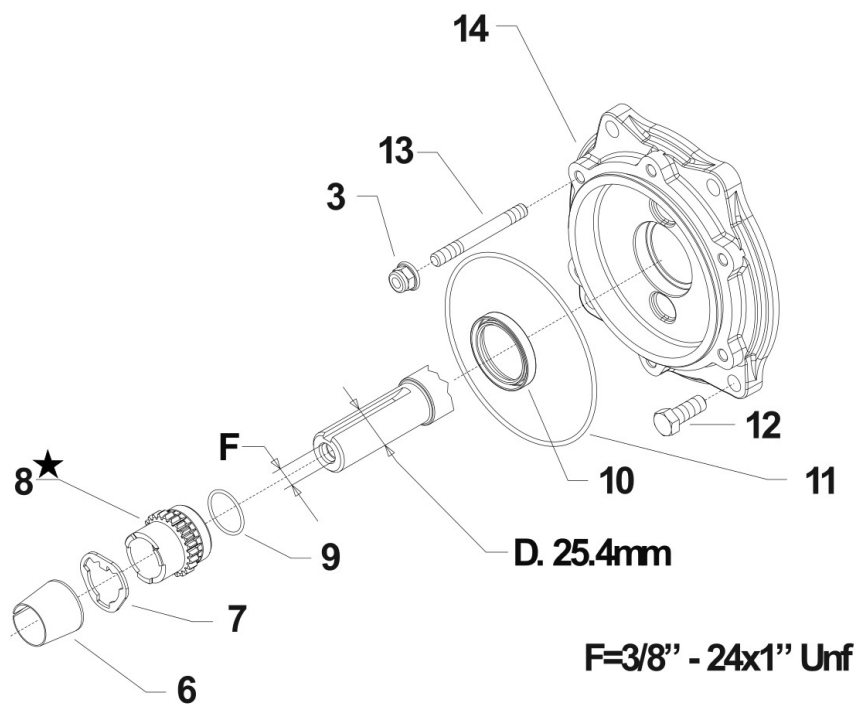

Gx390★ - B&S V 16 HP★

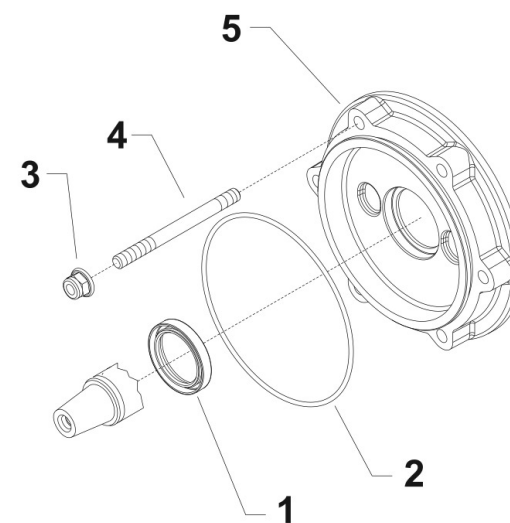

L100



i = info - stop 2 sec. ★ = new part



Pos.	Id	Q.ty	Description	Note
1	38213202		OIL SEAL 32X45X7	
2	38119823		O-RING 3450 (113,97x2,62)	
3	31241083		SELFLOCK NUT M8	
4	31312097		STUD BOLT M8X98X16X28 8G	
5	53156207		ENGINE FLANGE	
6	56156281		CENTRING BUSH D.25,4	
7	56356239		FEEDER Q25	
8	52456236		PUMP GEAR	GX390A
8	52456363		PUMP GEAR	B&S V 16 HP
9	F0803075500		O-RING 2100 (25,12X1,78)	
10	38213500		OIL SEAL 35X47X7	
11	38119823		O-RING 3450 (113,97x2,62)	
12	31100015		SCREW TE 3/8X1	
13	31312073		STUD BOLT M8X73X14X20 8G	
14	53156205		ENGINE FLANGE Q25	



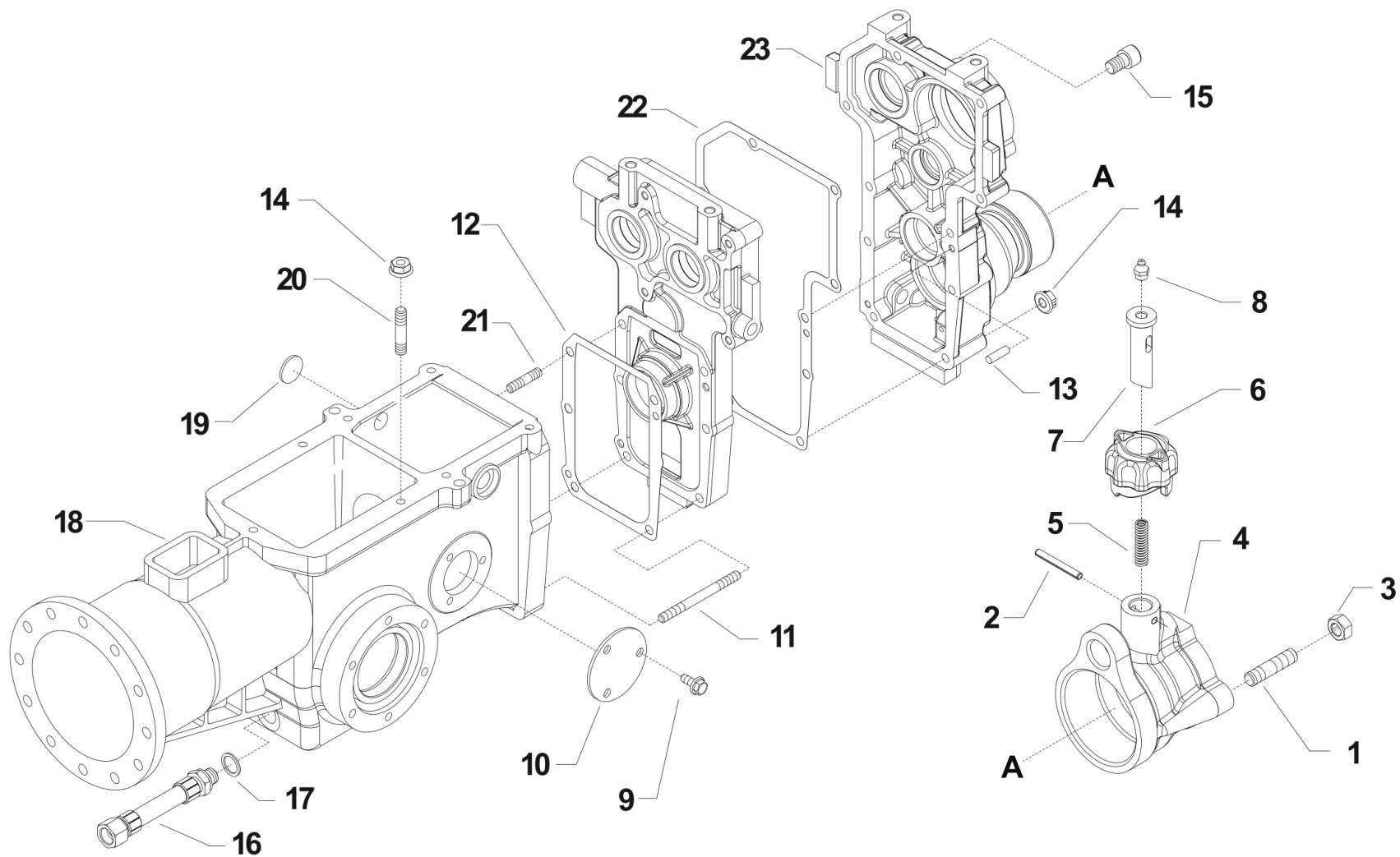

i = info - stop 2 sec. ★ = new part



BCS Motor mowers, BCS 2-wheel tractors - 660 HY WS PS
G.01.02.A0028_00 - GEARBOX

Pos.	Id	Q.ty	Description	Note
1	31312124		STUD BOLT 52XM12X1,25X22XM12X22 8G	
2	34213065		ROLL PIN	
3	31241124		SELFLOCK NUT M12x1,25	
4	51156710N		ATTACCO ATTREZZI 750/2	
5	58056646		SPRING 8KG	
6	552C0017		KNOB	
7	561C0013Z		STAKE	
8	30000001		LUBRICATOR M10	
9	31112083		SCREW M6X12	
10	56147520Z		COVER	
11	31312097		STUD BOLT M8X98X16X28 8G	
12	58056671		GASKET	
13	58043053		CYLINDRICAL PLUG	
14	31241084		SELFLOCK NUT M8 6S	
15	31152150		SCREW TCEI M16X25 UNI 5931	
16	59056244		SUCTION PIPE	
17	31480184		COPPER WASHER 16,7x22/1,5	
18	53156202N		BOX CASING	
19	30040133Z		PLUG 22 DIN 470	
20	31312078		STUD BOLT M8X32X14X14	
21	31312090		STUD BOLT M8X88X16X28 8G	
22	580C0148		FLANGE GASKET	
23	511C0151		H	



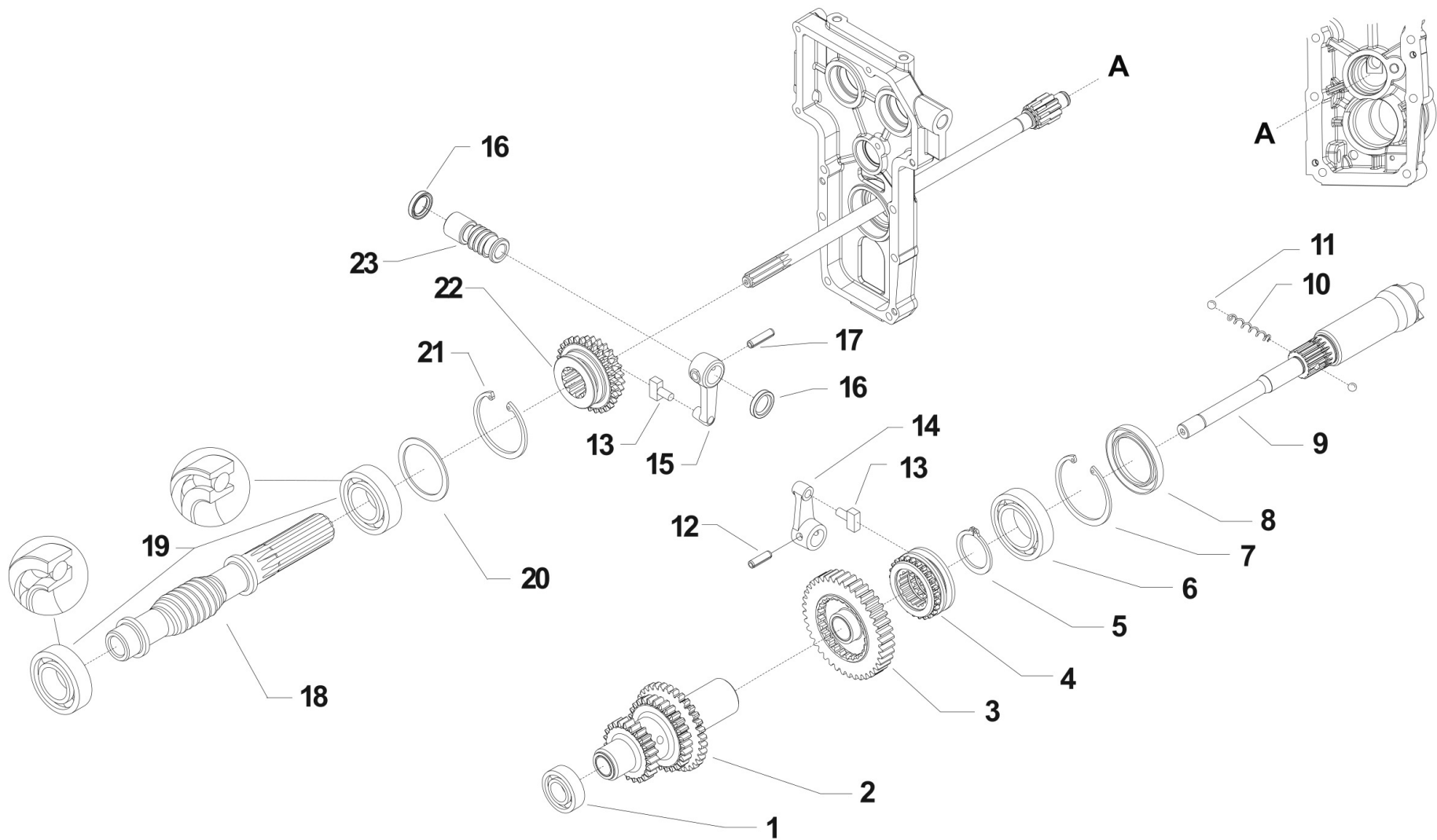

i = info - stop 2 sec. ★ = new part



BCS Motor mowers, BCS 2-wheel tractors - 660 HY WS PS

H.01.02.A0028_00 - GEAR SHAFT CLUTCH

Pos.	Id	Q.ty	Description	Note
1	37111150		BEARING 6202 (15X35X11)	
2	590C0165		TRIPLE GEAR	
3	590C0168		GEAR	
4	52456706		PTO COUPLING	
5	35121031		SEEGER RING E 30 UNI 7436	
6	37112229		BEARING 6006 (30X55X13) SKF	
7	35111055		SEEGER RING I 55 DIN 472	
8	38214201		OIL SEAL 42X56X7	
9	524C0167		PTO SHAFT	
10	58056391		SPRING	
11	37910832		BALL 1/4	
12	34213061		ROLL PIN	
13	58043086		SHOE	
14	52456390		LEVER	
15	52456389		LEVER	
16	38211400		OIL SEAL 14X22X4	
17	34213060		ROLL PIN	
18	56456479		SCREW 4 SN	
19	37141250		BEARING 7205-B OBL SKF	
20	56356328		ADJUSTING RING SP=1,5	
20	56356329		ADJUSTING RING SP=1,6	
20	56356330		ADJUSTING RING SP=1,7	
20	56356331		ADJUSTING RING SP=1,8	
21	35111053		SEEGER RING I 52 UNI 7438	
22	524C0227		SLIDING HYDRO	
23	564C0226		DENTIERA	



BCS Motor mowers, BCS 2-wheel tractors - 660 HY WS PS

H.01.02.A0028_00 - GEAR SHAFT CLUTCH

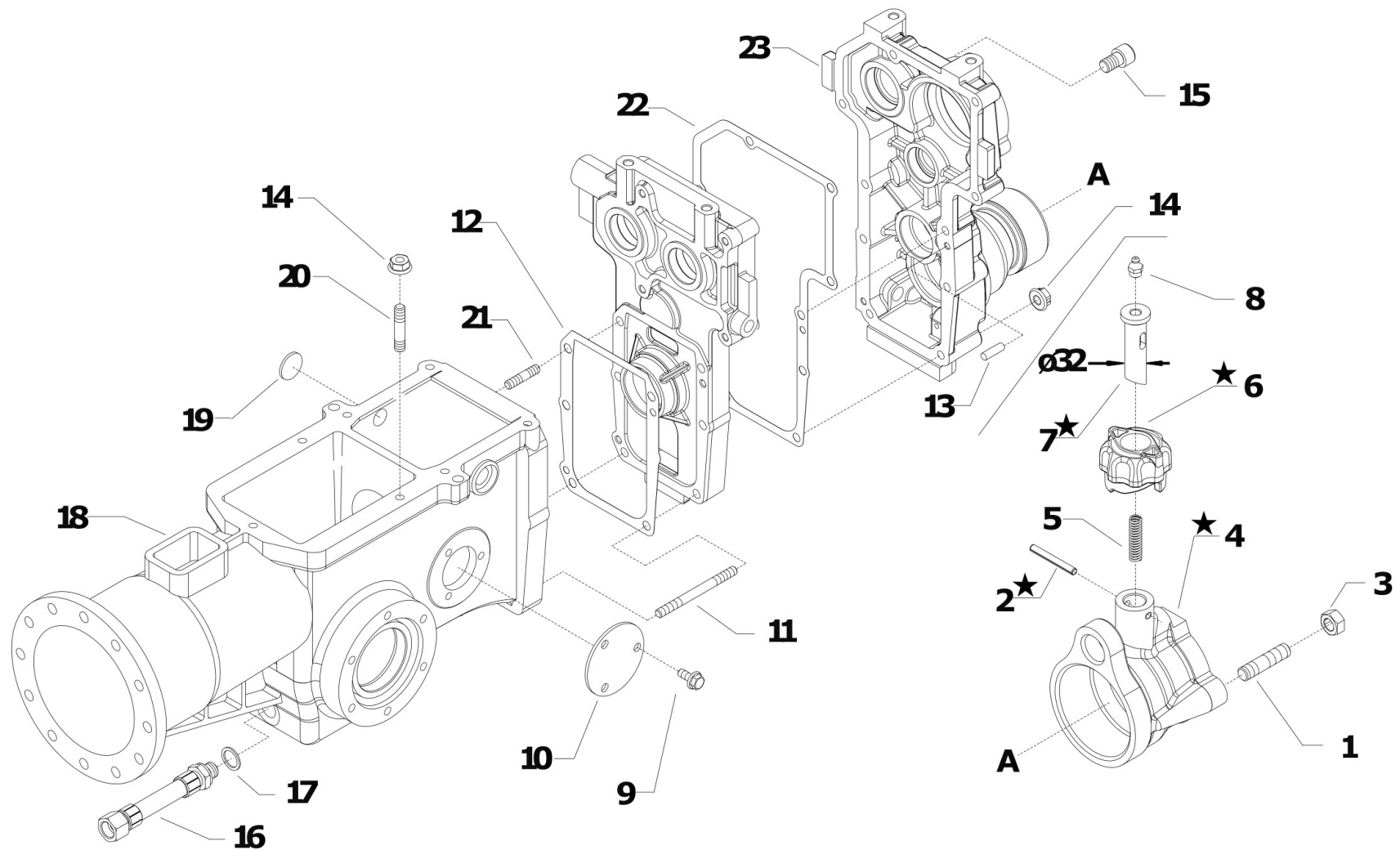

i = info - stop 2 sec. ★ = new part



Pos.	Id	Q.ty	Description	Note
1	31312124		STUD BOLT 52XM12X1,25X22XM12X22 8G	
2	34213066		ROLL PIN	
3	31241124		SELFLOCK NUT M12x1,25	
4	511C0072N		CONNECTION	
5	58056646		SPRING 8KG	
6	552C0062		KNOB	
7	561C0064Z		STAKE	
8	30000001		LUBRICATOR M10	
9	31112083		SCREW M6X12	
10	56147520Z		COVER	
11	31312097		STUD BOLT M8X98X16X28 8G	
12	58056671		GASKET	
13	58043053		CYLINDRICAL PLUG	
14	31241084		SELFLOCK NUT M8 6S	
15	31152150		SCREW TCEI M16X25 UNI 5931	
16	59056244		SUCTION PIPE	
17	31480184		COPPER WASHER 16,7x22/1,5	
18	53156202N		BOX CASING	
19	30040133Z		PLUG 22 DIN 470	
20	31312078		STUD BOLT M8X32X14X14	
21	31312090		STUD BOLT M8X88X16X28 8G	
22	580C0148		FLANGE GASKET	
23	511C0151		H	



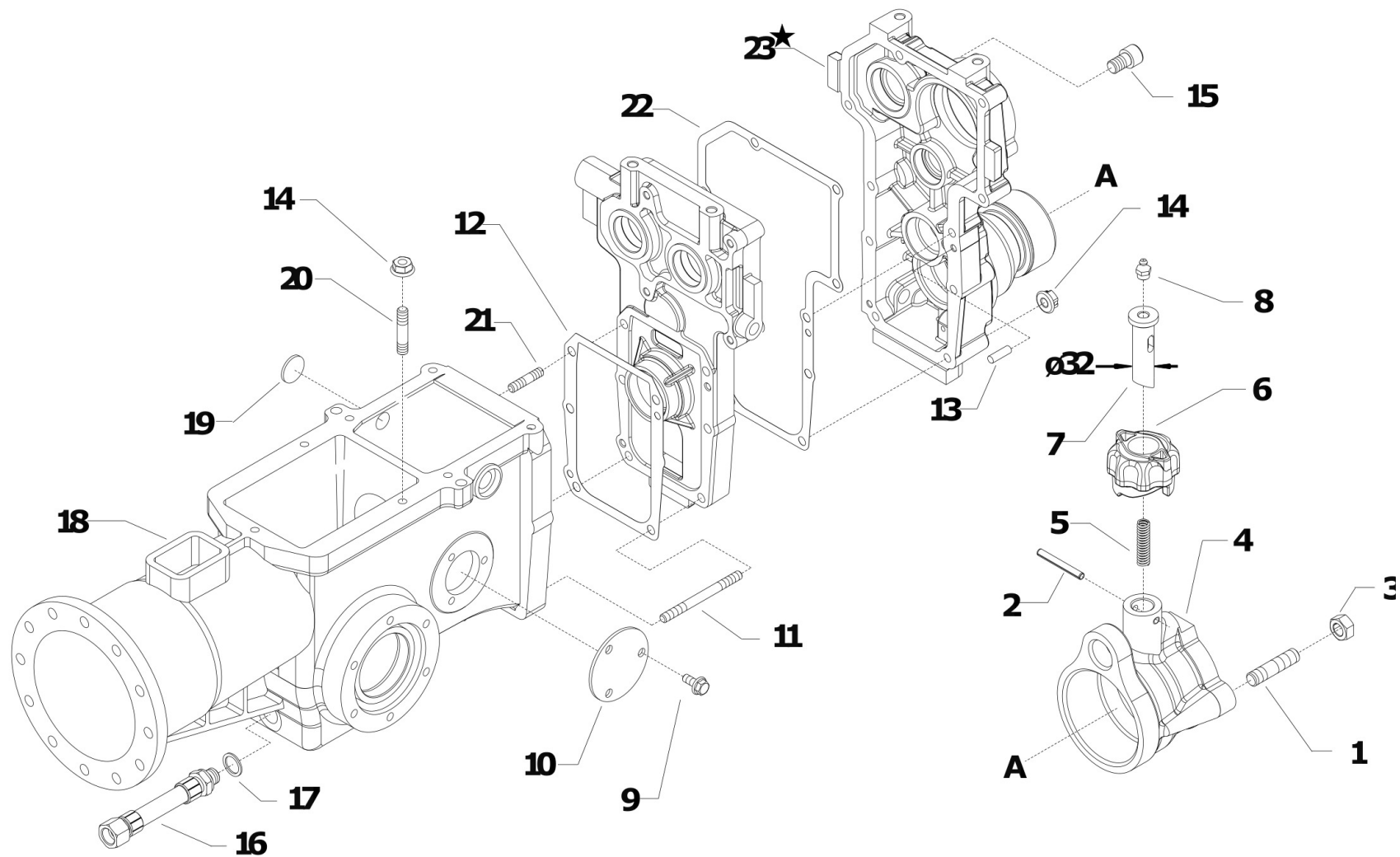



i = info - stop 2 sec. ★ = new part



Pos.	Id	Q.ty	Description	Note
1	31312124		STUD BOLT 52XM12X1,25X22XM12X22 8G	
2	34213066		ROLL PIN	
3	31241124		SELFLOCK NUT M12x1,25	
4	511C0072N		CONNECTION	
5	58056646		SPRING 8KG	
6	552C0062		KNOB	
7	561C0064Z		STAKE	
8	30000001		LUBRICATOR M10	
9	31112083		SCREW M6X12	
10	56147520Z		COVER	
11	31312097		STUD BOLT M8X98X16X28 8G	
12	58056671		GASKET	
13	58043053		CYLINDRICAL PLUG	
14	31241084		SELFLOCK NUT M8 6S	
15	31152150		SCREW TCEI M16X25 UNI 5931	
16	59056244		SUCTION PIPE	
17	31480184		COPPER WASHER 16,7x22/1,5	
18	53156202N		BOX CASING	
19	30040133Z		PLUG 22 DIN 470	
20	31312078		STUD BOLT M8X32X14X14	
21	31312090		STUD BOLT M8X88X16X28 8G	
22	580C0148		FLANGE GASKET	
23	511C0560		H	REPLACES 511C0151

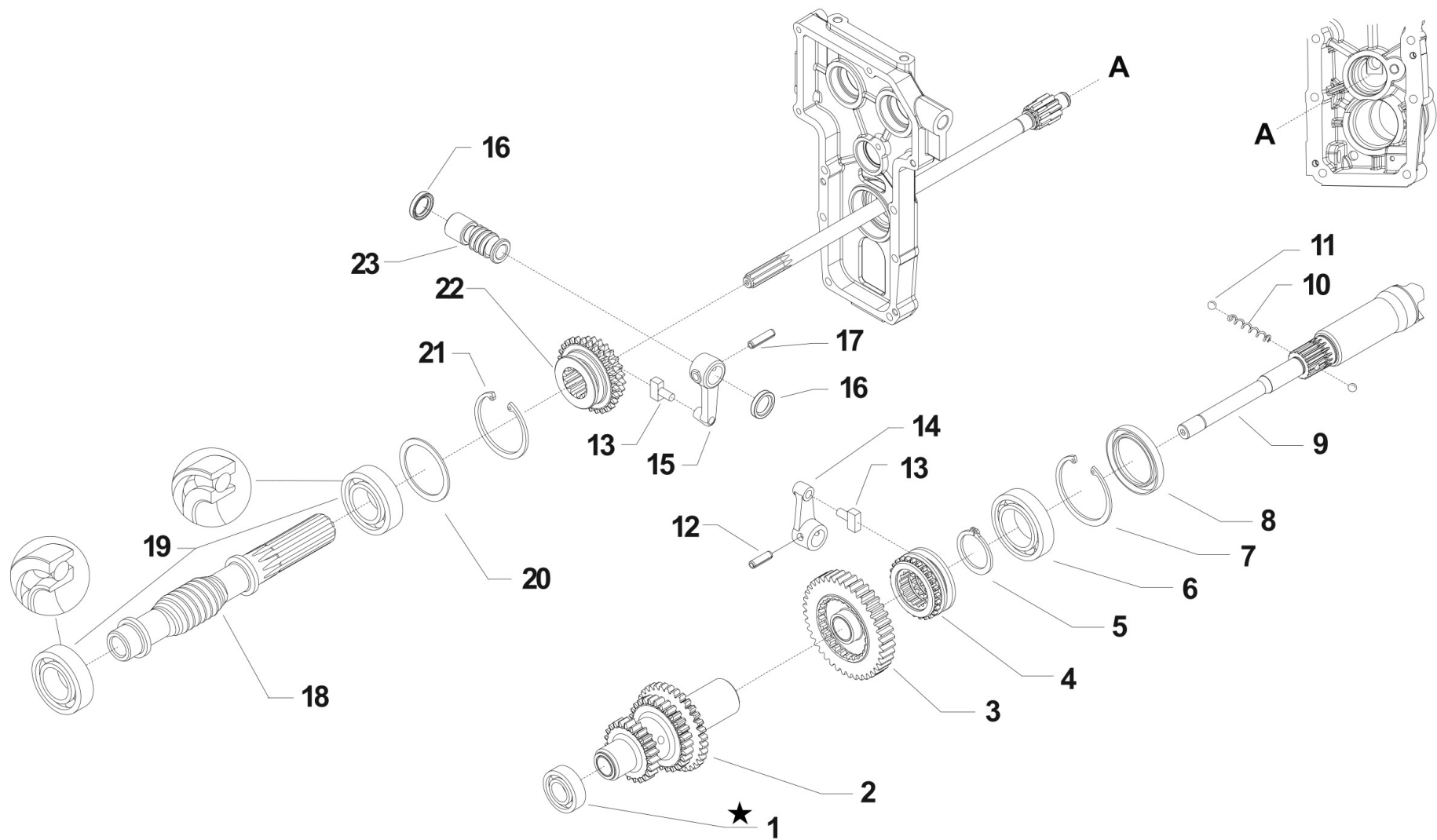



i = info - stop 2 sec. ★ = new part



BCS Motor mowers, BCS 2-wheel tractors - 660 HY WS PS

H.01.02.A0028_01 - GEAR SHAFT CLUTCH

Pos.	Id	Q.ty	Description	Note
1	37111151		BEARING 6202 (15X35X11)	REPLACES 37111150
2	590C0165		TRIPLE GEAR	
3	590C0168		GEAR	
4	52456706		PTO COUPLING	
5	35121031		SEEGER RING E 30 UNI 7436	
6	37112229		BEARING 6006 (30X55X13) SKF	
7	35111055		SEEGER RING I 55 DIN 472	
8	38214201		OIL SEAL 42X56X7	
9	524C0167		PTO SHAFT	
10	58056391		SPRING	
11	37910832		BALL 1/4	
12	34213061		ROLL PIN	
13	58043086		SHOE	
14	52456390		LEVER	
15	52456389		LEVER	
16	38211400		OIL SEAL 14X22X4	
17	34213060		ROLL PIN	
18	56456479		SCREW 4 SN	
19	37141250		BEARING 7205-B OBL SKF	
20	56356328		ADJUSTING RING SP=1,5	
20	56356329		ADJUSTING RING SP=1,6	
20	56356330		ADJUSTING RING SP=1,7	
20	56356331		ADJUSTING RING SP=1,8	
21	35111053		SEEGER RING I 52 UNI 7438	
22	524C0227		SLIDING HYDRO	
23	564C0226		DENTIERA	



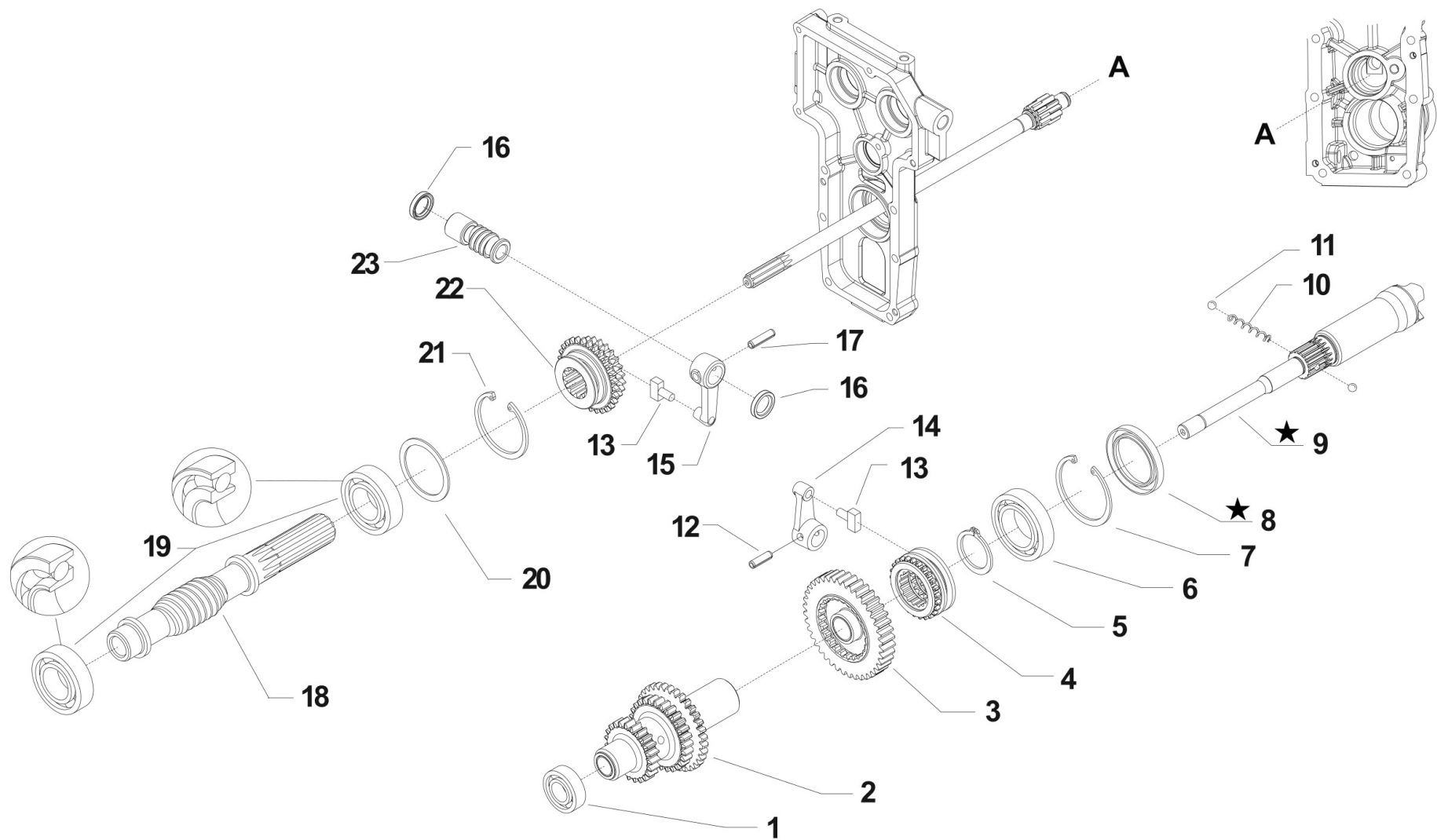

i = info - stop 2 sec. ★ = new part



BCS Motor mowers, BCS 2-wheel tractors - 660 HY WS PS

H.01.02.A0028_02 - GEAR SHAFT CLUTCH

Pos.	Id	Q.ty	Description	Note
1	37111151		BEARING 6202 (15X35X11)	
2	590C0165		TRIPLE GEAR	
3	590C0168		GEAR	
4	52456706		PTO COUPLING	
5	35121031		SEEGER RING E 30 UNI 7436	
6	37112229		BEARING 6006 (30X55X13) SKF	
7	35111055		SEEGER RING I 55 DIN 472	
8	38214207		OIL SEAL 42X55X7	REPLACES 38214201
9	524C0063		PTO SHAFT	REPLACES 524C0167
10	58056391		SPRING	
11	37910832		BALL 1/4	
12	34213061		ROLL PIN	
13	58043086		SHOE	
14	52456390		LEVER	
15	52456389		LEVER	
16	38211400		OIL SEAL 14X22X4	
17	34213060		ROLL PIN	
18	56456479		SCREW 4 SN	
19	37141250		BEARING 7205-B OBL SKF	
20	56356328		ADJUSTING RING SP=1,5	
20	56356329		ADJUSTING RING SP=1,6	
20	56356330		ADJUSTING RING SP=1,7	
20	56356331		ADJUSTING RING SP=1,8	
21	35111053		SEEGER RING I 52 UNI 7438	
22	524C0227		SLIDING HYDRO	
23	564C0226		DENTIERA	



BCS Motor mowers, BCS 2-wheel tractors - 660 HY WS PS

H.01.02.A0028_02 - GEAR SHAFT CLUTCH

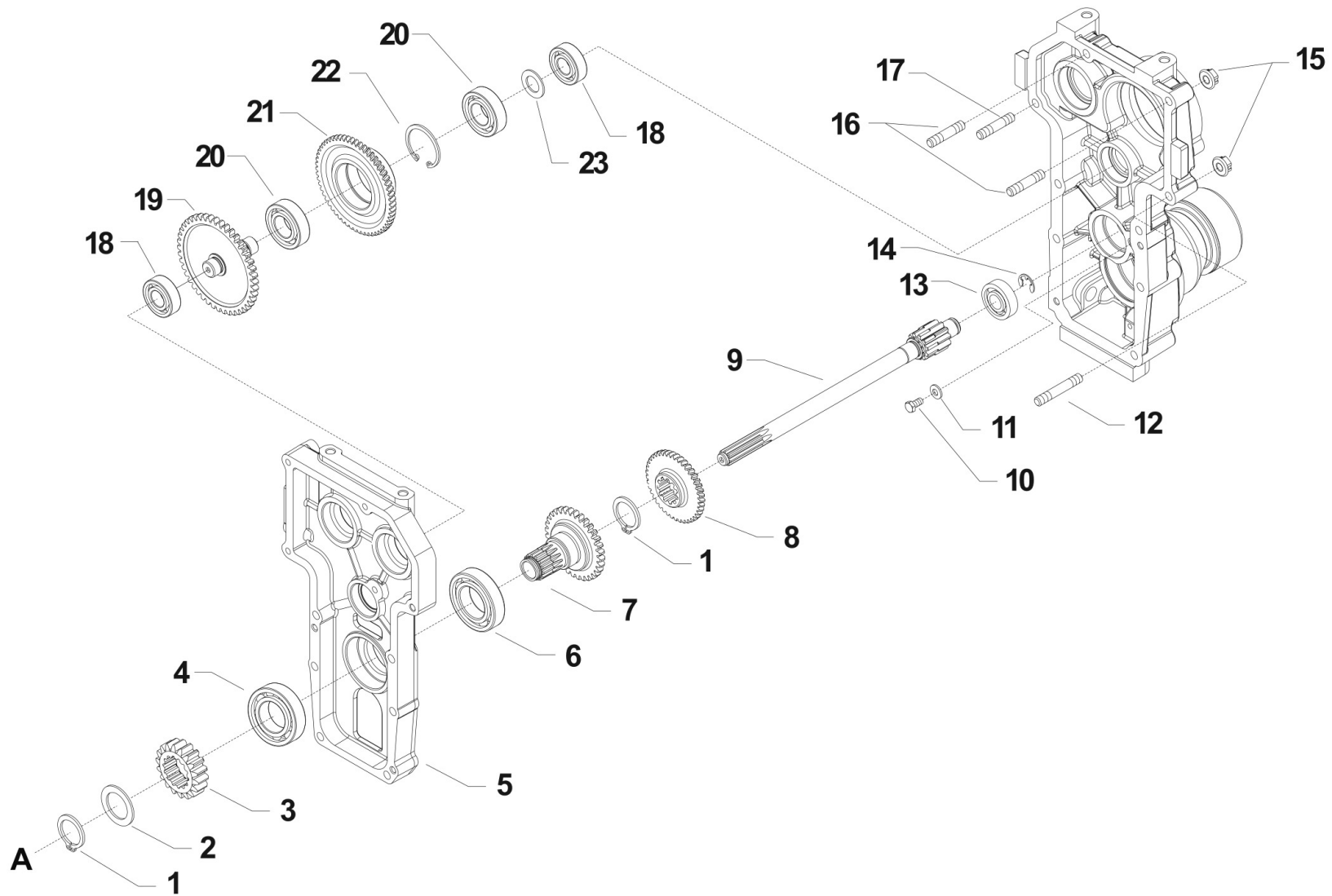

i = info - stop 2 sec. ★ = new part



BCS Motor mowers, BCS 2-wheel tractors - 660 HY WS PS

H.02.02.A0028_00 - REFERENCE GEAR / SHAFT CLUTCH

Pos.	Id	Q.ty	Description	Note
1	35121022		SEEGER RING E 20 UNI 7436	
2	563C0200		WASHER 20.3X30X1.5	
3	524C0162		LAY GEAR	
4	37111253		BEARING 6005 (25X47X12)	
5	532C0152		FLANGE	
6	37112229		BEARING 6006 (30X55X13) SKF	
7	590C0164		DEFLECTION SHAFT	
8	524C0160		OUTPUT GEAR	
9	524C0163		HYDRO FIRST SHAFT	
10	31112210		SCREW TE M10X20 UNI 5739	
11	31421101		WASHER 10 DIN 679	
12	31312086		STUD BOLT M8X56X20X14	
13	37111152		BEARING 6302 (15X42X13) SKF	
14	35211120		SEEGER RING E 12 UNI 7434	
15	31241084		SELFLOCK NUT M8 6S	
16	31312089		STUD BOLT M8x52x14x18	
17	31312079		STDU N M8X40X14X20 8G	
18	37111150		BEARING 6202 (15X35X11)	
19	524C0159		PUMP GEAR	
20	37111200		BEARING 6004 (20X42X12)	
21	524C0158		IDLE ENGINE GEAR	
22	F0801310000		RING	
23	563C0218		WASHER	



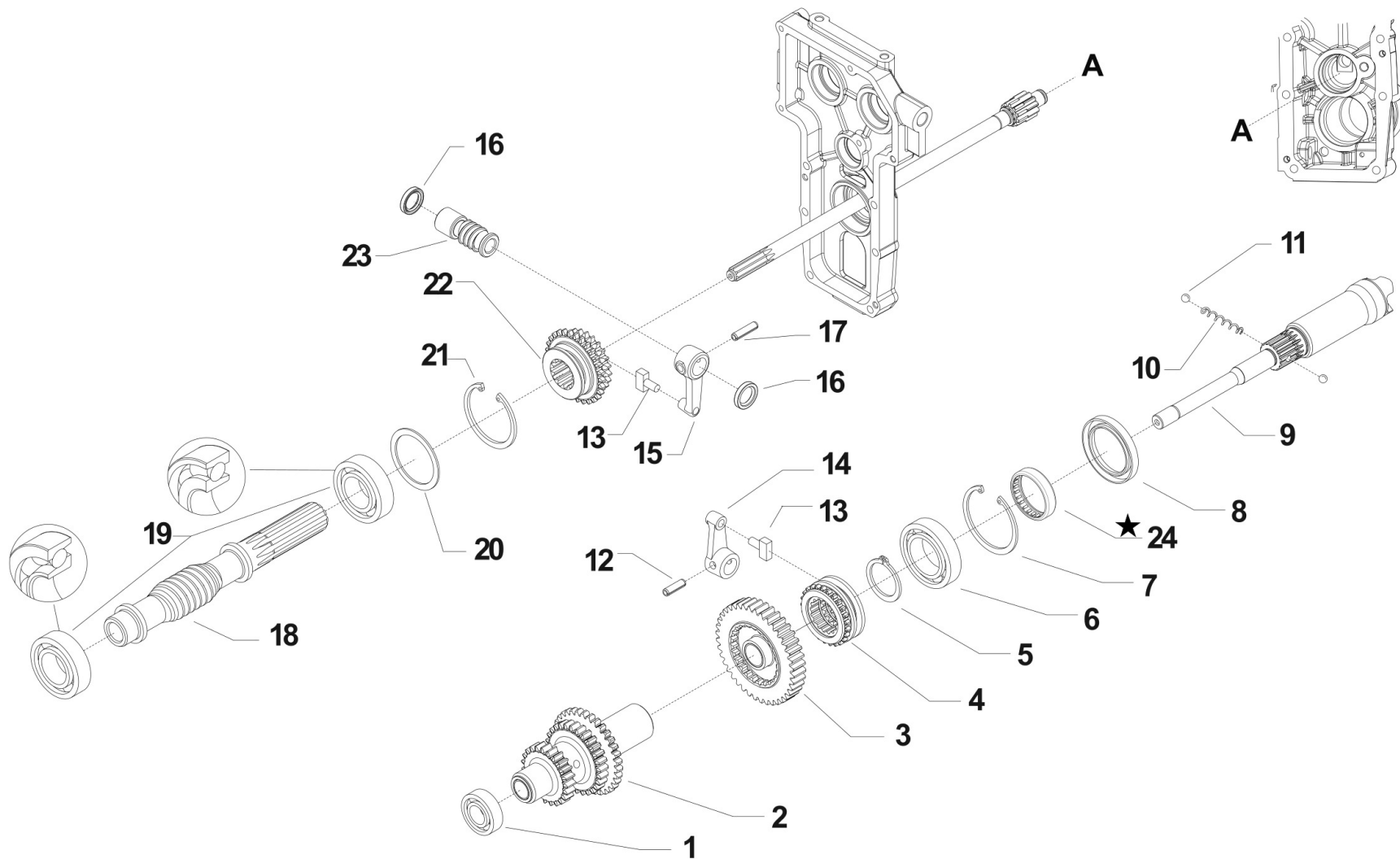

i = info - stop 2 sec. ★ = new part



BCS Motor mowers, BCS 2-wheel tractors - 660 HY WS PS

H.01.02.A0028_03 - GEAR SHAFT CLUTCH

Pos.	Id	Q.ty	Description	Note
1	37111151		BEARING 6202 (15X35X11)	
2	590C0165		TRIPLE GEAR	
3	590C0168		GEAR	
4	52456706		PTO COUPLING	
5	35121031		SEEGER RING E 30 UNI 7436	
6	37112229		BEARING 6006 (30X55X13) SKF	
7	35111055		SEEGER RING I 55 DIN 472	
8	38214207		OIL SEAL 42X55X7	
9	524C0063		PTO SHAFT	
10	58056391		SPRING	
11	37910832		BALL 1/4	
12	34213061		ROLL PIN	
13	58043086		SHOE	
14	52456390		LEVER	
15	52456389		LEVER	
16	38211400		OIL SEAL 14X22X4	
17	34213060		ROLL PIN	
18	56456479		SCREW 4 SN	
19	37141250		BEARING 7205-B OBL SKF	
20	56356328		ADJUSTING RING SP=1,5	
20	56356329		ADJUSTING RING SP=1,6	
20	56356330		ADJUSTING RING SP=1,7	
20	56356331		ADJUSTING RING SP=1,8	
21	35111053		SEEGER RING I 52 UNI 7438	
22	524C0227		SLIDING HYDRO	
23	564C0226		DENTIERA	
24	37331450		BUSHING R/NI HK (45X52X12)	



BCS Motor mowers, BCS 2-wheel tractors - 660 HY WS PS

H.01.02.A0028_03 - GEAR SHAFT CLUTCH

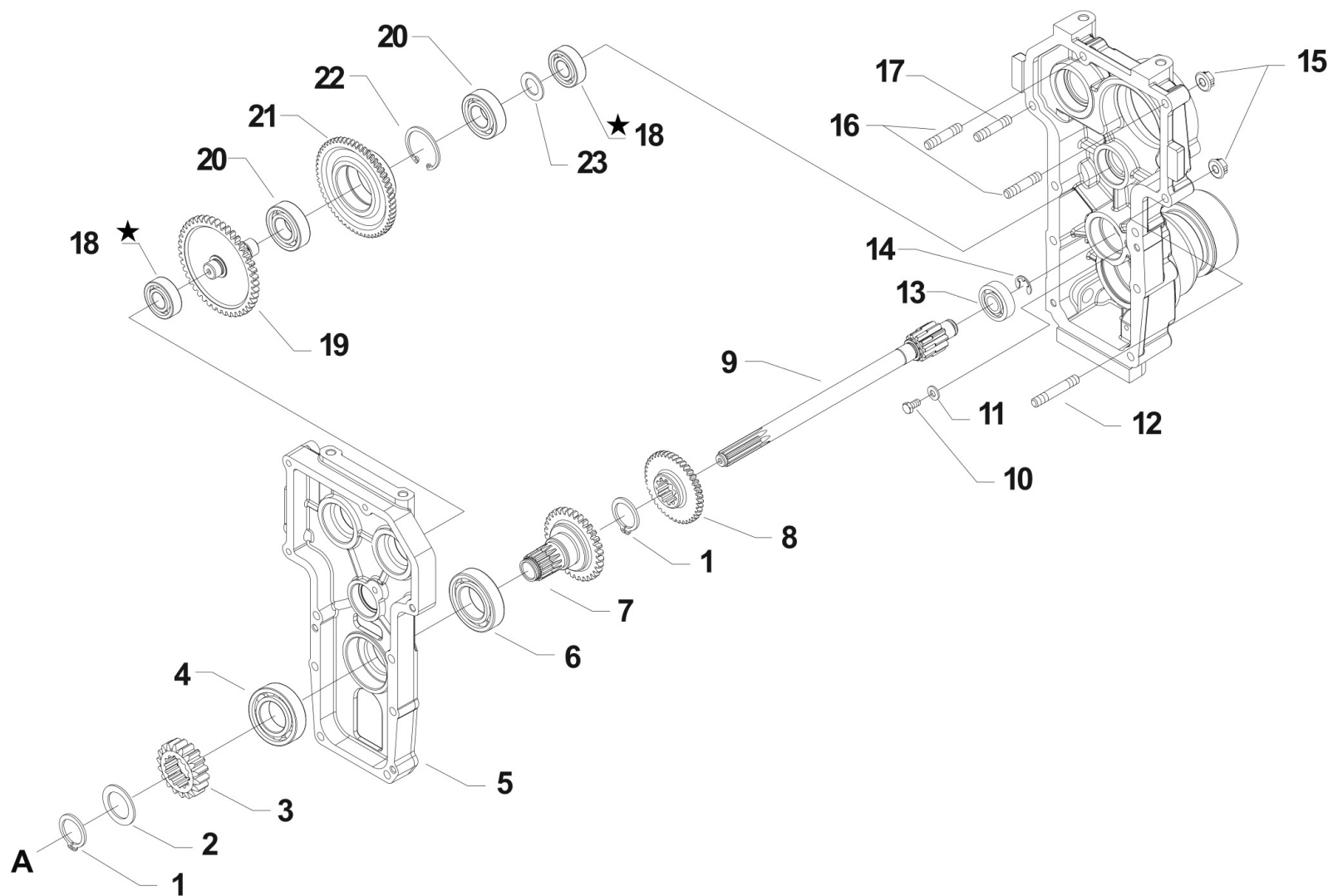

i = info - stop 2 sec. ★ = new part



BCS Motor mowers, BCS 2-wheel tractors - 660 HY WS PS

H.02.02.A0028_01 - REFERENCE GEAR / SHAFT CLUTCH

Pos.	Id	Q.ty	Description	Note
1	35121022		SEEGER RING E 20 UNI 7436	
2	563C0200		WASHER 20.3X30X1.5	
3	524C0162		LAY GEAR	
4	37111253		BEARING 6005 (25X47X12)	
5	532C0152		FLANGE	
6	37112229		BEARING 6006 (30X55X13) SKF	
7	590C0164		DEFLECTION SHAFT	
8	524C0160		OUTPUT GEAR	
9	524C0163		HYDRO FIRST SHAFT	
10	31112210		SCREW TE M10X20 UNI 5739	
11	31421101		WASHER 10 DIN 679	
12	31312086		STUD BOLT M8X56X20X14	
13	37111152		BEARING 6302 (15X42X13) SKF	
14	35211120		SEEGER RING E 12 UNI 7434	
15	31241084		SELFLOCK NUT M8 6S	
16	31312089		STUD BOLT M8x52x14x18	
17	31312079		STDU N M8X40X14X20 8G	
18	37111151		BEARING 6202 (15X35X11)	REPLACES 37111150
19	524C0159		PUMP GEAR	
20	37111200		BEARING 6004 (20X42X12)	
21	524C0158		IDLE ENGINE GEAR	
22	F0801310000		RING	
23	563C0218		WASHER	



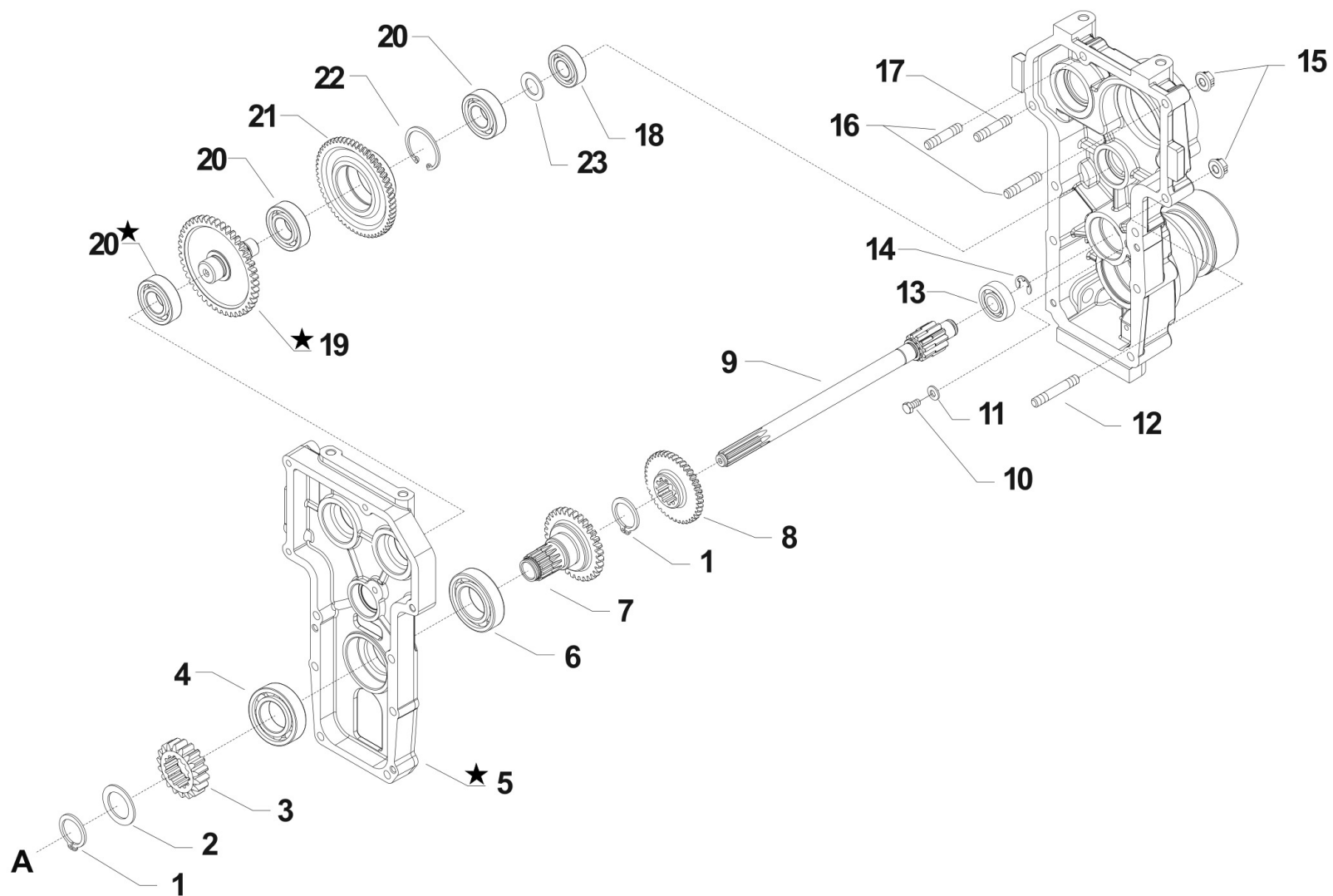

i = info - stop 2 sec. ★ = new part



BCS Motor mowers, BCS 2-wheel tractors - 660 HY WS PS

H.02.02.A0028_02 - REFERENCE GEAR / SHAFT CLUTCH

Pos.	Id	Q.ty	Description	Note
1	35121022		SEEGER RING E 20 UNI 7436	
2	563C0200		WASHER 20.3X30X1.5	
3	524C0162		LAY GEAR	
4	37111253		BEARING 6005 (25X47X12)	
5	532C0439		FLANGE	REPLACES 532C0152 + 524C0159 + 37111150
6	37112229		BEARING 6006 (30X55X13) SKF	
7	590C0164		DEFLECTION SHAFT	
8	524C0160		OUTPUT GEAR	
9	524C0163		HYDRO FIRST SHAFT	
10	31112210		SCREW TE M10X20 UNI 5739	
11	31421101		WASHER 10 DIN 679	
12	31312086		STUD BOLT M8X56X20X14	
13	37111152		BEARING 6302 (15X42X13) SKF	
14	35211120		SEEGER RING E 12 UNI 7434	
15	31241084		SELFLOCK NUT M8 6S	
16	31312089		STUD BOLT M8x52x14x18	
17	31312079		STDU N M8X40X14X20 8G	
18	37111151		BEARING 6202 (15X35X11)	
19	524C0445		PUMP GEAR	REPLACES 532C0152 + 524C0159 + 37111150
20	37111200		BEARING 6004 (20X42X12)	
21	524C0158		IDLE ENGINE GEAR	
22	F0801310000		RING	
23	563C0218		WASHER	



BCS Motor mowers, BCS 2-wheel tractors - 660 HY WS PS

H.02.02.A0028_02 - REFERENCE GEAR / SHAFT CLUTCH

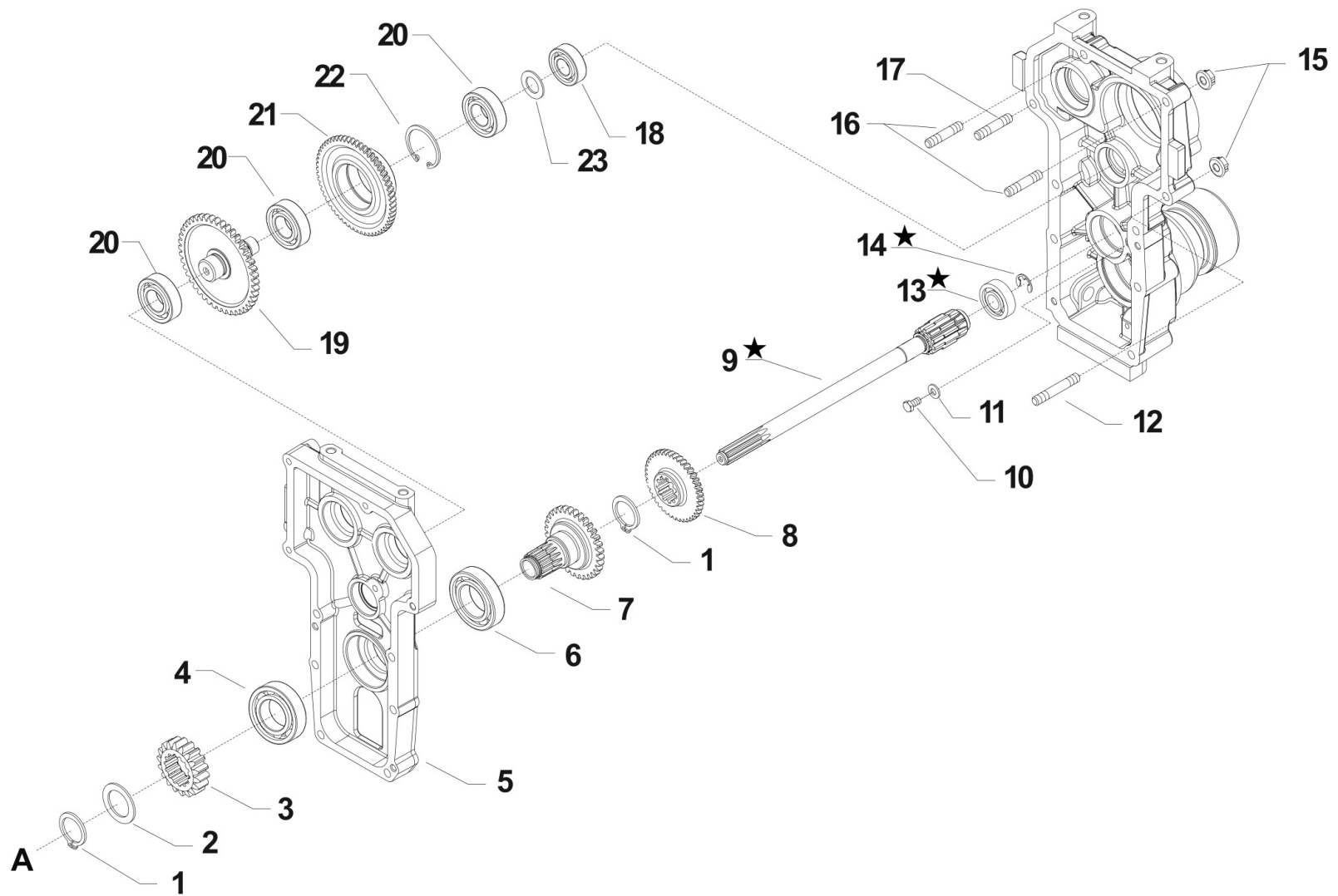

i = info - stop 2 sec. ★ = new part



BCS Motor mowers, BCS 2-wheel tractors - 660 HY WS PS

H.02.02.A0028_03 - REFERENCE GEAR / SHAFT CLUTCH

Pos.	Id	Q.ty	Description	Note
1	35121022		SEEGER RING E 20 UNI 7436	
2	563C0200		WASHER 20.3X30X1.5	
3	524C0162		LAY GEAR	
4	37111253		BEARING 6005 (25X47X12)	
5	532C0439		FLANGE	
6	37112229		BEARING 6006 (30X55X13) SKF	
7	590C0164		DEFLECTION SHAFT	
8	524C0160		OUTPUT GEAR	
9	524C1674		ALBERO PRIMARIO IDRO	REPLACES 35211120 + 524C0163 + 37111152
10	31112210		SCREW TE M10X20 UNI 5739	
11	31421101		WASHER 10 DIN 679	
12	31312086		STUD BOLT M8X56X20X14	
13	37111253		BEARING 6005 (25X47X12)	REPLACES 35211120 + 524C0163 + 37111152
14	35211150		SEEGER RING E 15 UNI 7434	REPLACES 35211120 + 524C0163 + 37111152
15	31241084		SELFLOCK NUT M8 6S	
16	31312089		STUD BOLT M8x52x14x18	
17	31312079		STDU N M8X40X14X20 8G	
18	37111151		BEARING 6202 (15X35X11)	
19	524C0445		PUMP GEAR	
20	37111200		BEARING 6004 (20X42X12)	
21	524C0158		IDLE ENGINE GEAR	
22	F0801310000		RING	
23	563C0218		WASHER	



BCS Motor mowers, BCS 2-wheel tractors - 660 HY WS PS

H.02.02.A0028_03 - REFERENCE GEAR / SHAFT CLUTCH

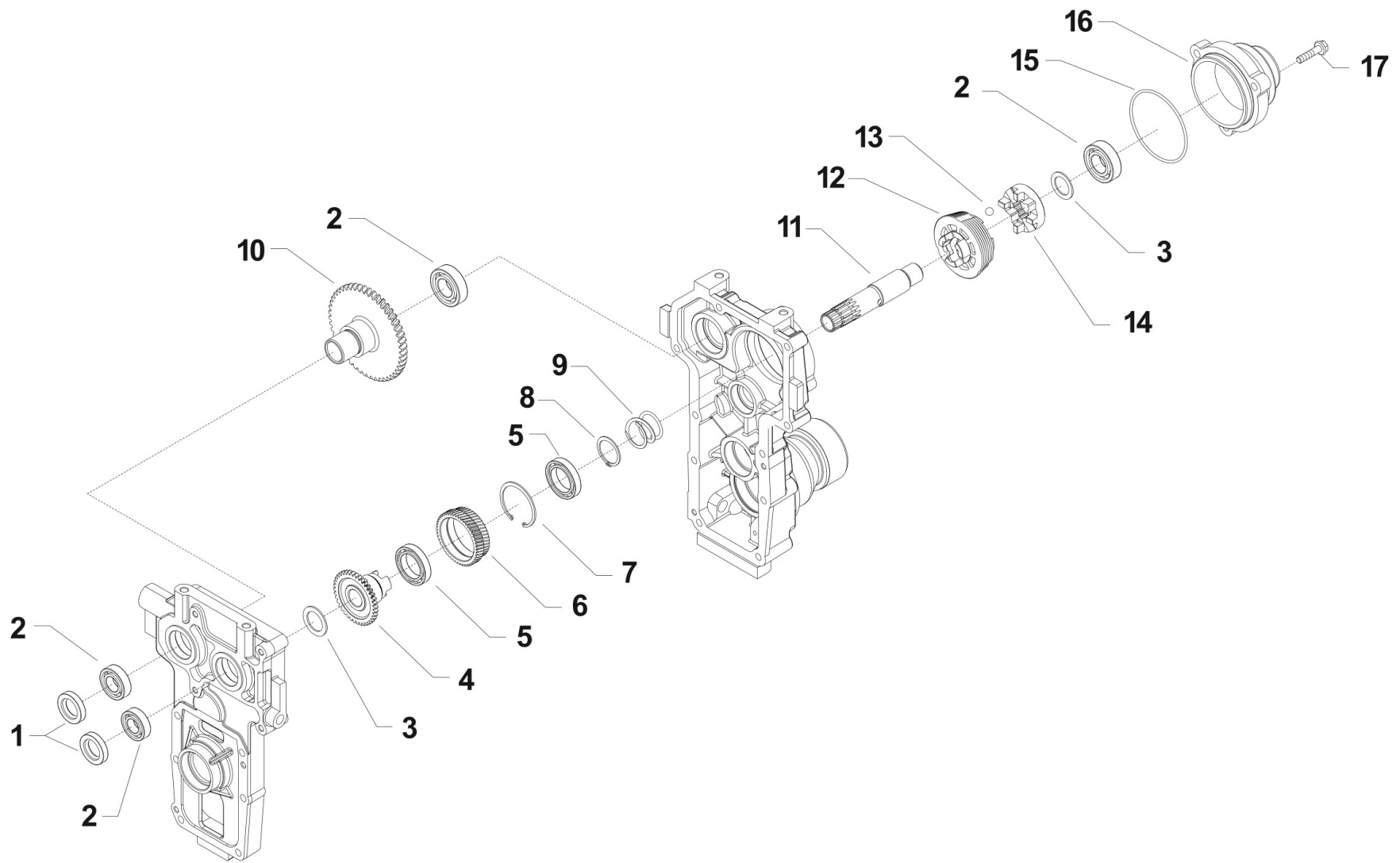

i = info - stop 2 sec. ★ = new part



BCS Motor mowers, BCS 2-wheel tractors - 660 HY WS PS

H.03.02.A0028_00 - AUTOMATIC BRAKE

Pos.	Id	Q.ty	Description	Note
1	38212001		OIL SEAL 20X35X7	
2	37111200		BEARING 6004 (20X42X12)	
3	563C0200		WASHER 20.3X30X1.5	
4	524C0156		HYDRO ENGINE GEAR	
5	37111362		BEARING 61908 (40x62x12)SKF	
6	524C0157		LAY GEAR	
7	35111062		SEEGER RING I 62 DIN 472	
8	F0801275000		SEEGER RING E 36 UNI 7435	
9	580C0374		SPRING	
10	590C0293		PUMP GEAR	
11	590C0292		CRANK SHAFT	
12	541C0246		CONE	
13	37911032		BALL 5/16	
14	524C0245		HYDRO BREAK COUPLING	
15	38117587		O-RING 3300 (75,87X2,62)	
16	524C0244N		BRAKE BELL FLANGE	
17	31112165		SCREW TE C/F M8X35 DIN 6921 8G	



BCS Motor mowers, BCS 2-wheel tractors - 660 HY WS PS

H.03.02.A0028_00 - AUTOMATIC BRAKE

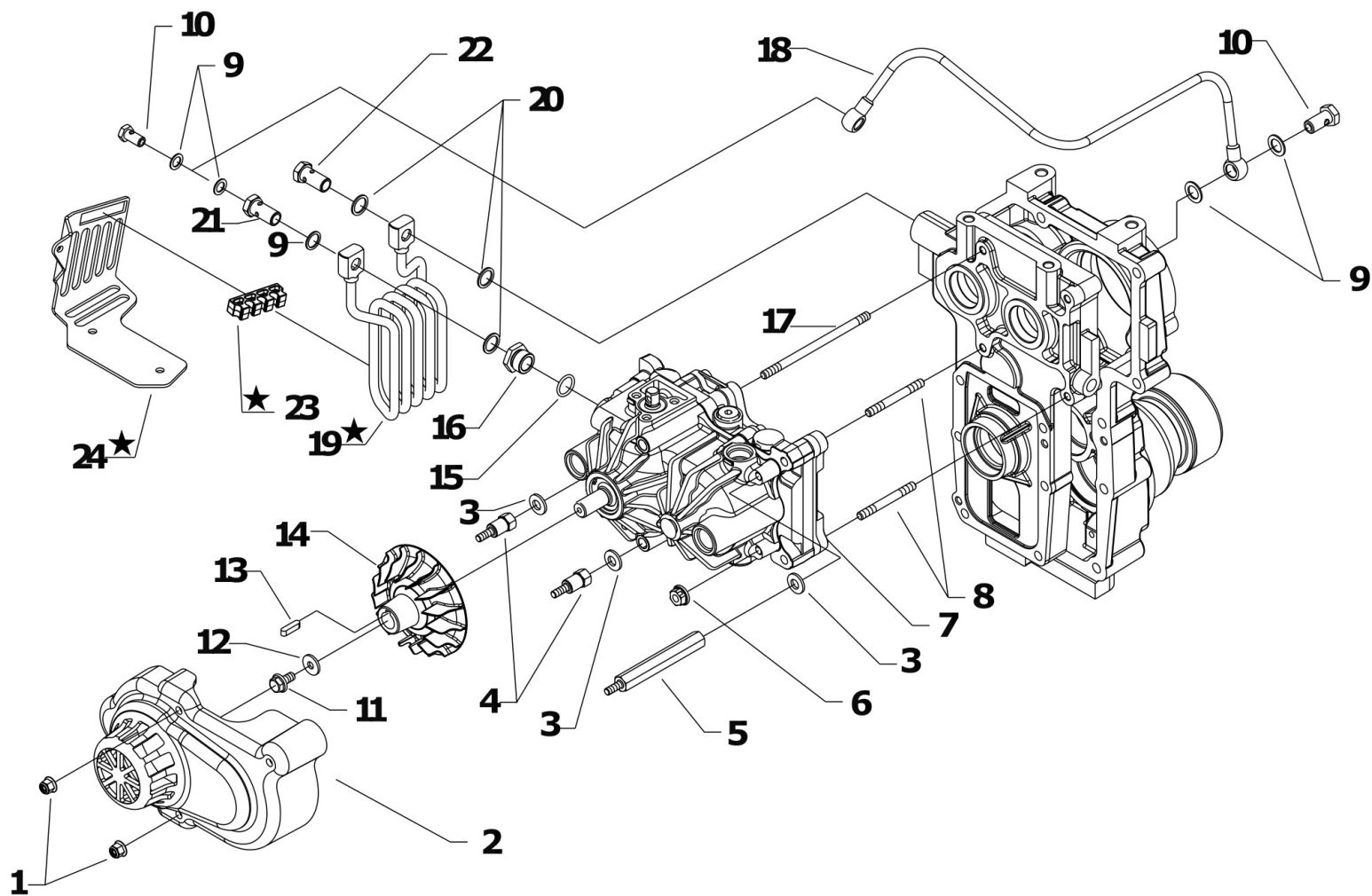

 [Click for info](#)

★ = new part



Pos.	Id	Q.ty	Description	Note
1	31241066		SELFLOCK M6 FL NY DIN 6926	
2	552C0154		SUMP	
3	31421083		WASHER	
4	563C0173Z		SMALL COLUMN	
5	563C0174		SMALL COLUMN	
6	31241084		SELFLOCK NUT M8 6S	
7	581C0290		GR. KANZAKI KHS-13JH	
8	580C0224Z		STUD BOLT	
9	31480180		COPPER WASHER 10,2x16/1	
10	58192747		PIPE FITTING	
11	31112083		SCREW M6X12	
12	31411066		WASHER 6,6x18	
13	34321050		KEY 5X5X20	
14	552C0153		PIPE	
15	38111872		O-RING 3075 (18,72x2,62)	
16	561C0196Z		REDUCTION	
17	580C0223Z		STUD BOLT	
18	590C0128Z		PIPE	
19	590C0461Z		RADIATORE C.TO ZNT	REPLACE 590C0417Z
20	31480184		COPPER WASHER 16,7x22/1,5	
21	580C0149Z		SCREW G3/8 G1/8	
22	F0843109020		PIPE FITTING	
23	551C0456		DAMPER	
24	561C0408N		HYDR. RADIATOR GUARD	



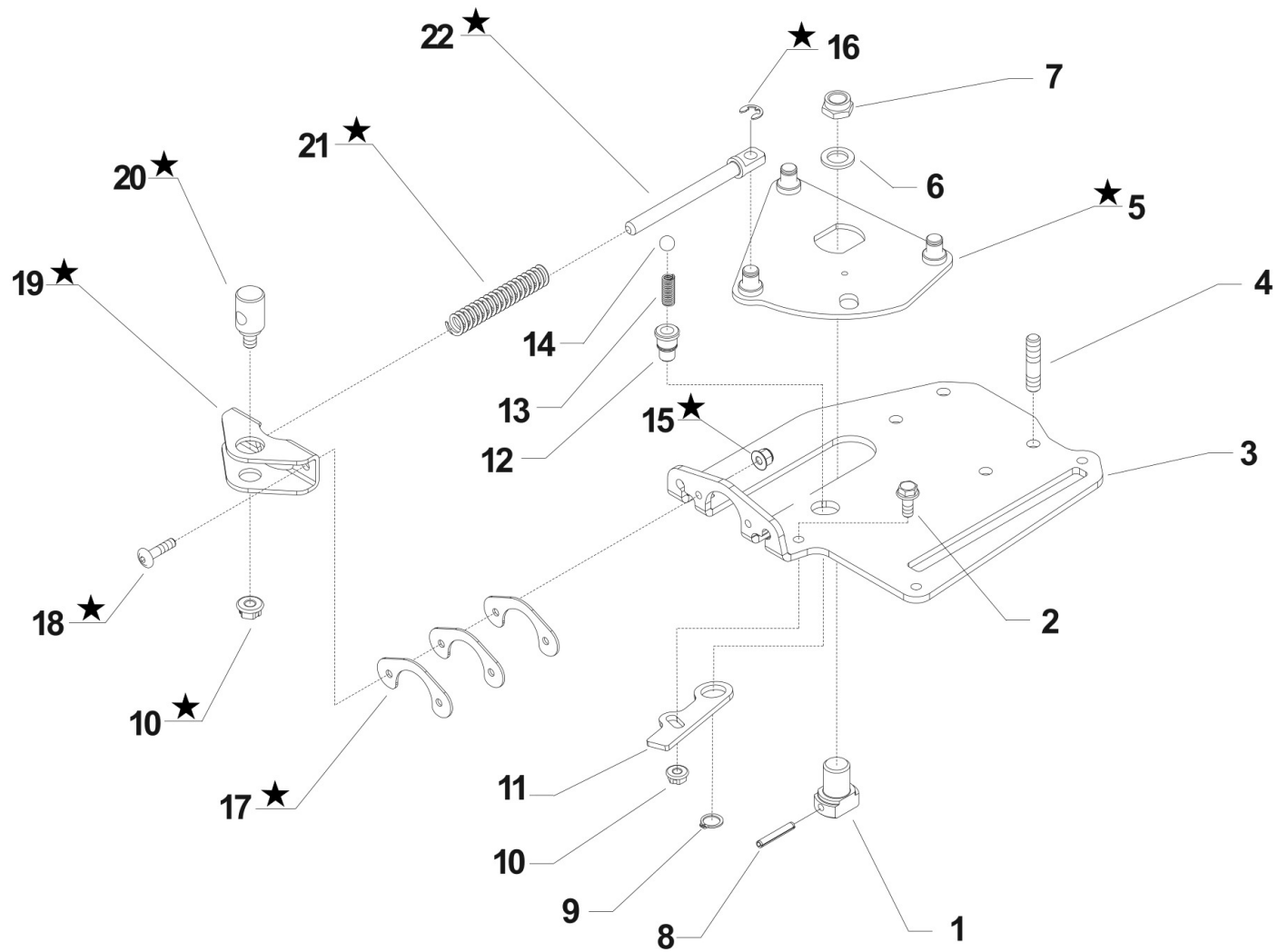

i = info - stop 2 sec. ★ = new part



BCS Motor mowers, BCS 2-wheel tractors - 660 HY WS PS

H.05.02.A0028_02 - PUMP CONTROL

Pos.	Id	Q.ty	Description	Note
1	563C0177Z		SLEEVE	
2	31112170		SCREW TE C/F M8X20 DIN 6921	
3	561C0202N		RETAINING PLATE	
3	561C0415N		RETAINING PLATE	BRINGS & STRATTON - EASYRIDER
4	31312103		STUD BOLT M10X46X24X16	
5	590C0474Z		FARFALLA C.TA ER ZNT	
6	31414190		WASHER 19	
7	31241182		SELFLOCK NUT M18X1,5	
8	34213055		ROLL PIN	
9	35121018		SEEGER RING E 18 DIN 471	
10	31241084		SELFLOCK NUT M8 6S	
11	561C0135Z		LEVER	
12	563C0208Z		SLEEVE	
13	58056683		SPRING	
14	37911532		BALL 15/32	
15	31241066		SELFLOCK M6 FL NY DIN 6926	
16	35211050		SEEGER RING E 5 UNI 7434	
17	561C1454Z		ADATTATORE ZNT	
18	31121005		SCREW TBCEI FLANG. M6X25	
19	561C0443Z		CONTRASTO MOLLA ZNT	
20	561C0444Z		GUIDE PIN	
21	58056918		SPRING	
22	561C0440Z		GUIDE ROD	



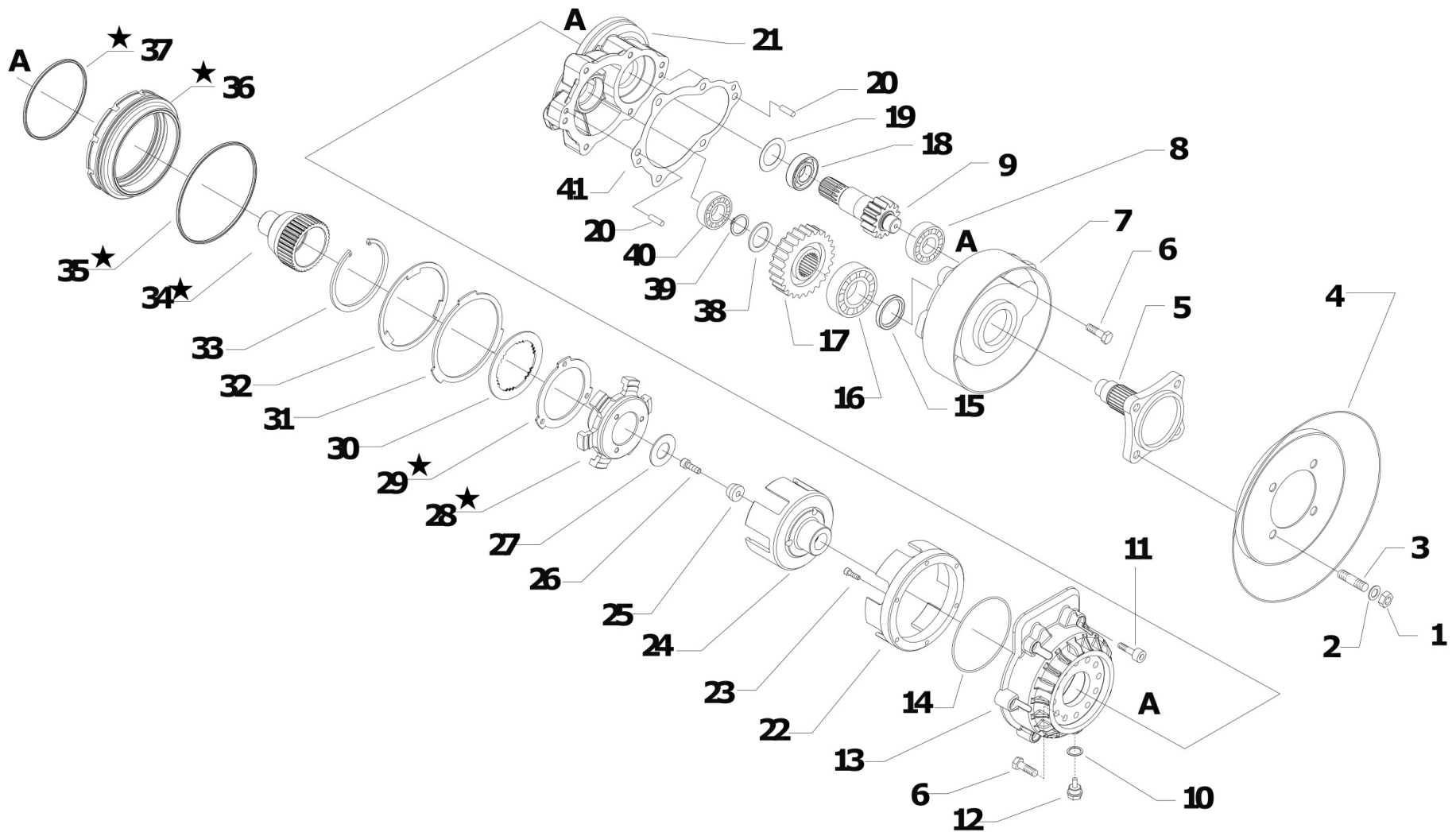

 [Click for info](#)

★ = new part



BCS Motor mowers, BCS 2-wheel tractors - 660 HY WS PS

I.01.02.A0028_04 - CLUTCH STEERING

Pos.	Id	Q.ty	Description	Note
1	31241100		SELFLOCK HEXAGON NUT M10	
2	31423105		SPRING WASHER 10,5	
3	31312102		STUD BOLT M10X40X24X12	
4	56157807N		BOTTOM	
5	524C0251N		HYDRO WHEEL HALF SHAFT	
6	31112166		SCREW TE C/F M8X25 DIN 6921 8G	
7	53257808N		COVER	
8	37111201		BEARING 6204 (20X47X14)	
9	524C0234		HYDRO REDUCTION SHAFT	
10	F0844273090		GASKET 22X28X1,5 CU 99,5	
11	31152084		SCREW TCEI M8X35 UNI 5931	
12	58170021		PLUG	
13	532C0232N		CLUTCH HOUSING	
14	38119823		O-RING 3450 (113,97x2,62)	
15	38214001		OIL SEAL 40X52X7	
16	37111300		BEARING 6206 (30X62X16)	
17	52456564		GEAR Z26	
18	37141301		BEARING 7206-B OBL (30X62X16)	
19	31460615		SPRING	
20	58043053		CYLINDRICAL PLUG	
21	532C0252N		HYDRO FLANGE INTER. REDUCTION	
22	524C0472		RING	
23	31152063		SCREW TCEI M6X20 UNI 5931	
24	524C0233		CLUTCH HOUSING	
25	563C0235		SPECIAL WASHER	
26	31152085		SCREW TCEI M8X25 UNI 5931	
27	580C0497		MOLLA TZ 50x25.4x2 DIN 2093	REPLACE 31421500
28	524C0555		CAMPANA STELLATA 7-1	REPLACE 524C0492
29	563C0552		DISCO CONDOTTO IDRO SP.=2	REPLACE 563C0491



BCS Motor mowers, BCS 2-wheel tractors - 660 HY WS PS

I.01.02.A0028_04 - CLUTCH STEERING

Pos.	Id	Q.ty	Description	Note
30	563C0490		DISCO CONDUTTORE IDRO SP.=2	Nr 10
31	563C0494		BRAKE DISC	Nr 10
32	563C0493		DISCO FRENO INTERNO	Nr 8
33	F0801455000		SEEGER RING I 110 UNI 7437	
34	524C0556		TOOTHED BELL	
35	38141600		RING PTFE PRP02A02-1600-A-32-N	
36	572C0554		PISTON	REPLACE 572C0489
37	38109169		O-RING OR 4248 (120,24X3,53)	
38	31400190		SHIM	
39	35121026		SEEGER RING E 26 DIN 471	
40	37111200		BEARING 6004 (20X42X12)	
41	580C0147		SHEATH	



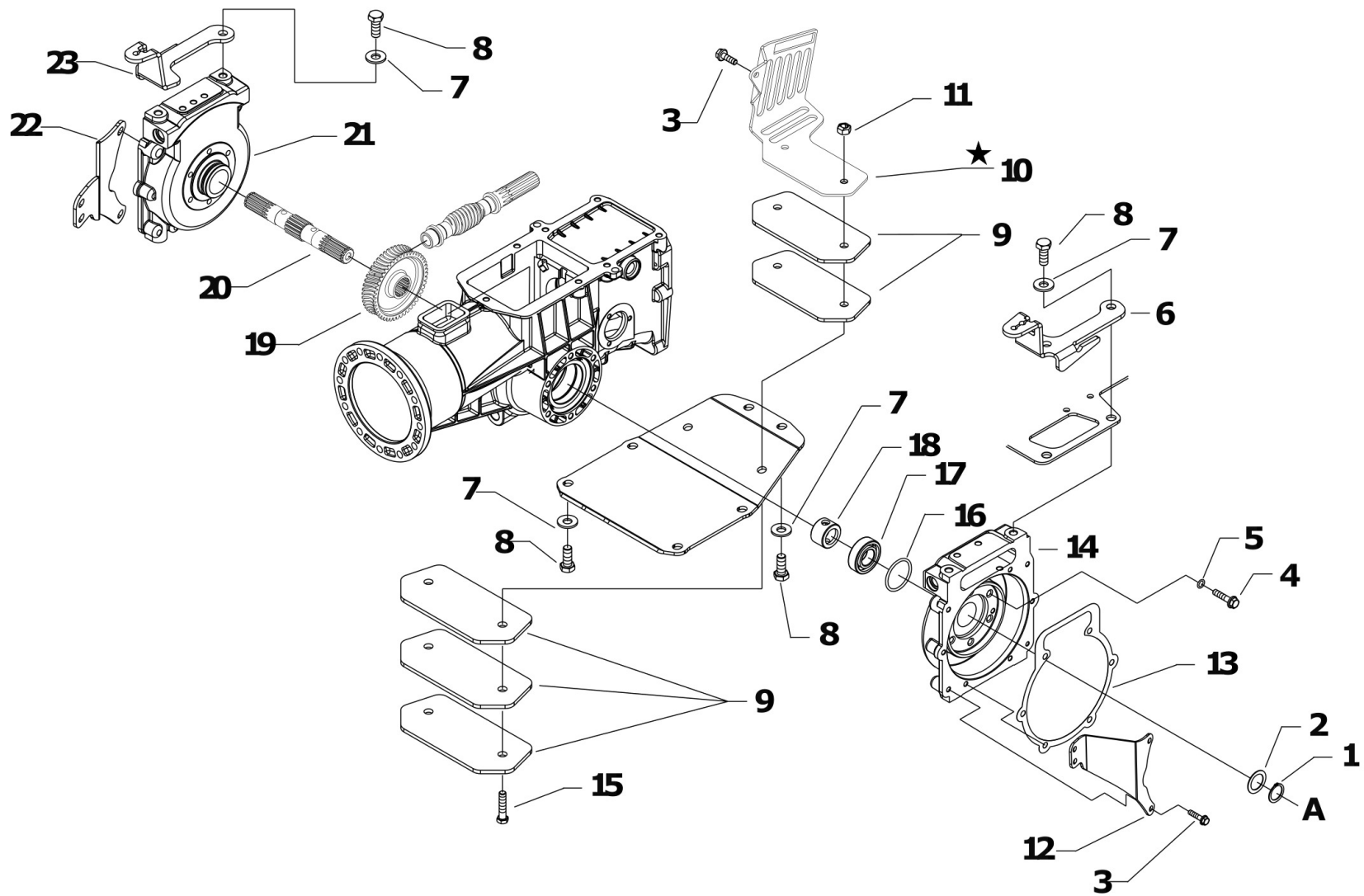

[i](#) Click for info

★ = new part



Pos.	Id	Q.ty	Description	Note
1	35121024		SEEGER RING	
2	31400206		SHIM PS 25x36/1	
3	31112166		SCREW TE C/F M8X25 DIN 6921 8G	
4	31112165		SCREW TE C/F M8X35 DIN 6921 8G	
5	38110873		O-RING 108 (8,73X1,78)	
6	561C0274N		HOLDER COUPLING	
7	31421130		WASHER	
8	31112272		SCREW TE M12X30 UNI 5739	TIGHTEN 8.5 kgm
9	561C0286N		BRACE	
10	561C0408N		HYDR. RADIATOR GUARD	
11	31241126		SELFLOCK NUT M12	
12	561C0266B		SHEET	
13	580C0146		GASKET	
14	513C0230N		FLANGE	
15	31112269		SCREW TE M12X55 UNI 5739	
16	38114445		O-RING 149 (44,45x3,53)	
17	37111250		BEARING	
18	561C0253		SPACER	
19	541C0184		CROWN WHEEL Z=47 (SINISTRORSA)	
20	564C0254		OUTPUT SHAFT	
21	513C0231N		FLANGE	
22	561C0267B		SHEET	
23	561C0275N		HOLDER COUPLING	



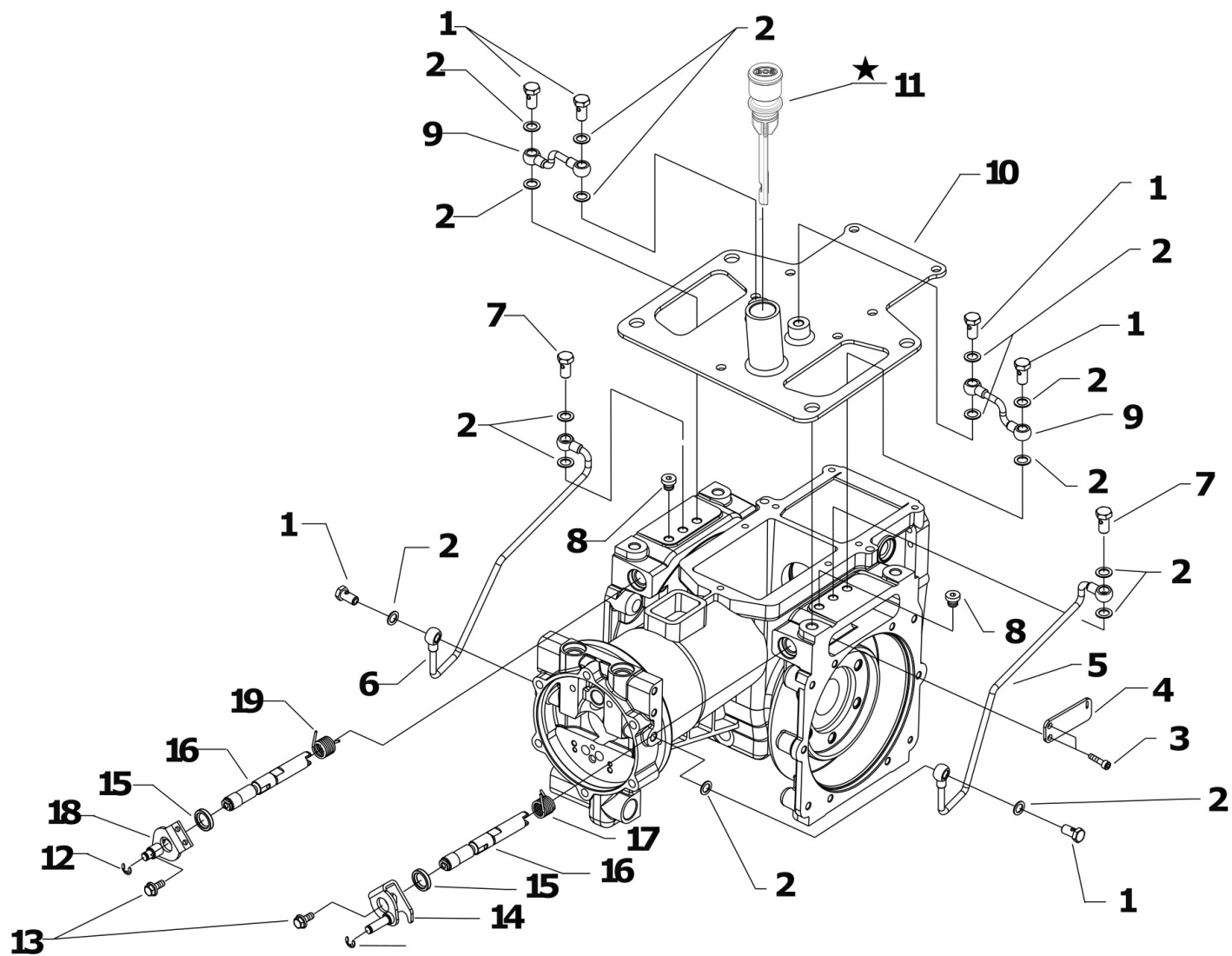

 [Click for info](#)

★ = new part



BCS Motor mowers, BCS 2-wheel tractors - 660 HY WS PS

I.03.02.A0028_02 - DRIVE AXLE WHEELS

Pos.	Id	Q.ty	Description	Note
1	58192747		PIPE FITTING	
2	31480180		COPPER WASHER 10,2x16/1	
3	31152064		SCREW TCEI M6X25 UNI 5931	
4	561C0273		SMALL PLATE	
5	590C0279Z		CONTROL LINE	
6	590C0281Z		CONTROL LINE	
7	58156448		PIPE FITTING	
8	580C0041		PLUG	
9	590C0283Z		VENT HOSE	
10	590C0276N		COVER	
11	592C1825		COMPLETE OIL CAP L	REPLACES 59015425
12	35211060		SEEGER RING E 6 UNI 7434	
13	31112084		SCREW TE C/F M6X14 DIN 6921 8G	
14	590C0255Z		BRAKE LEVER	
15	38211400		OIL SEAL 14X22X4	
16	524C0323		DISTRIBUTORE IDRO	REPLACE 524C0259
17	580C0264		SPRING	
18	590C0257Z		BRAKE LEVER	
19	580C0263		SPRING	



BCS Motor mowers, BCS 2-wheel tractors - 660 HY WS PS

I.03.02.A0028_02 - DRIVE AXLE WHEELS

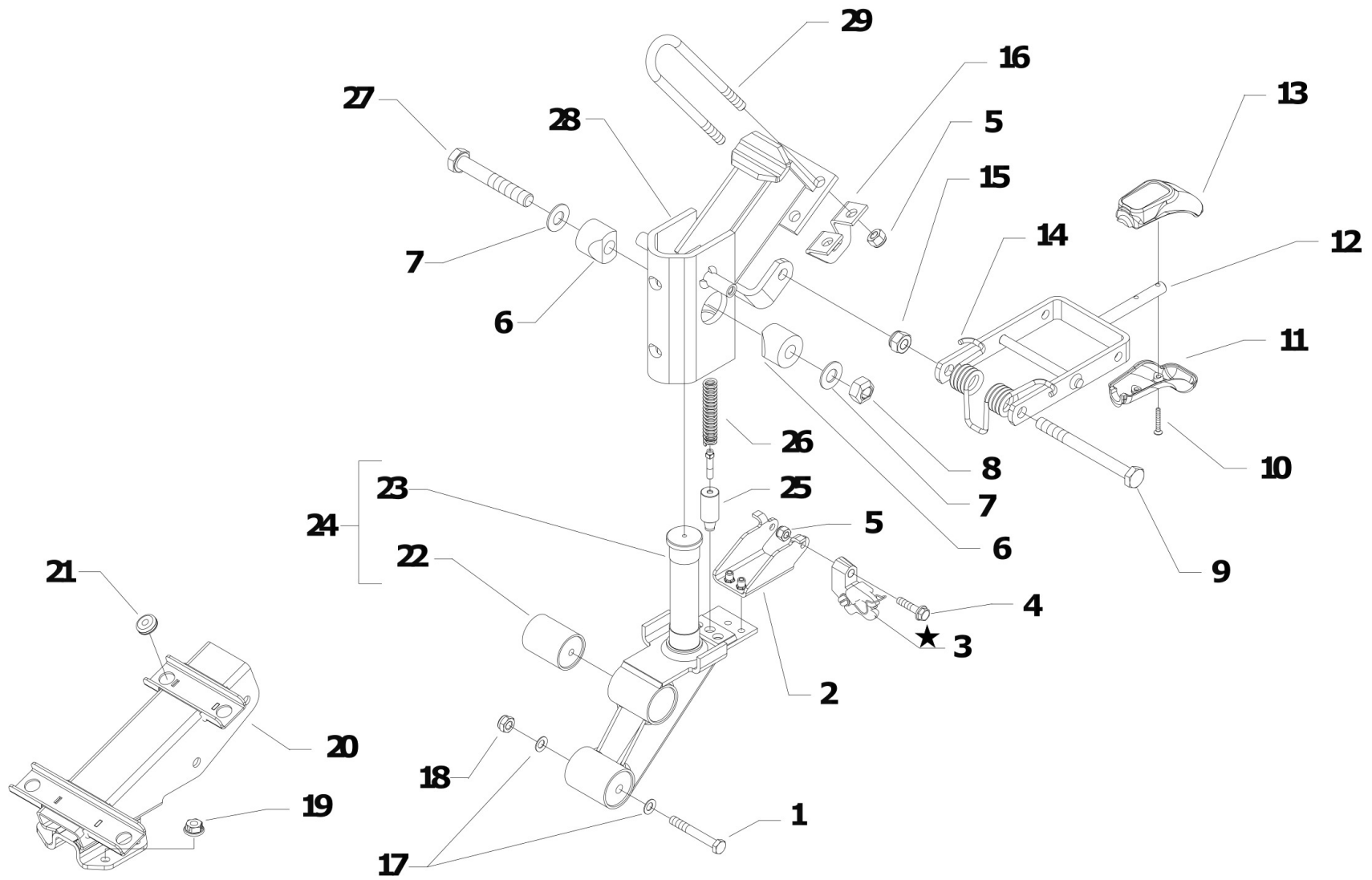

 [Click for info](#)

★ = new part



BCS Motor mowers, BCS 2-wheel tractors - 660 HY WS PS

J.01.02.A0028_03 - STEERING COLUMN

Pos.	Id	Q.ty	Description	Note
1	31112295		SCREW TE M12X90 UNI 5737	
2	59256880		CONNECTION	
3	59243337		ROD SUPPORT WITH SPRING	REPLACES 55243340
4	31112165		SCREW TE C/F M8X35 DIN 6921 8G	
5	31241080		HEXAGON SELFLOCK NUT M8	
6	52156917		WEDGE	
7	31421100		CUP SPRING 25X12,2X1,5 D2093	
8	31241126		SELFLOCK NUT M12	
9	31111229		SCREW TE M10X110 UNI 5737 8G	
10	31100451		SCREW 3,5X25	
11	55157213		GRIP	
12	59057010N		LEVER	
13	55157212		GRIP	
14	58056942		SPRING	
15	31241100		SELFLOCK HEXAGON NUT M10	
16	56156948		STOP	
17	31423130		SPRING WASHER EL 13 DIN 137-B	
18	31241121		SELFLOCK NUT M12	
19	31241084		SELFLOCK NUT M8 6S	
20	590C0528N		SUPPORTO PIANTONE MF C.TO VT	REPLACES 590C0179N
21	58056991		CABLE GLAND 90/200/30	
22	30010120		SILENT-BLOCK 12X40X58X66	
23	590C0210		COLUMN	
24	592C0367		COLUMN	
25	56356924		FERRULE	
26	58056918		SPRING	
27	31112293		SCREW TE M12X80 UNI 5737	
28	59056875		COLUMN	
29	56156940		U BOLT	



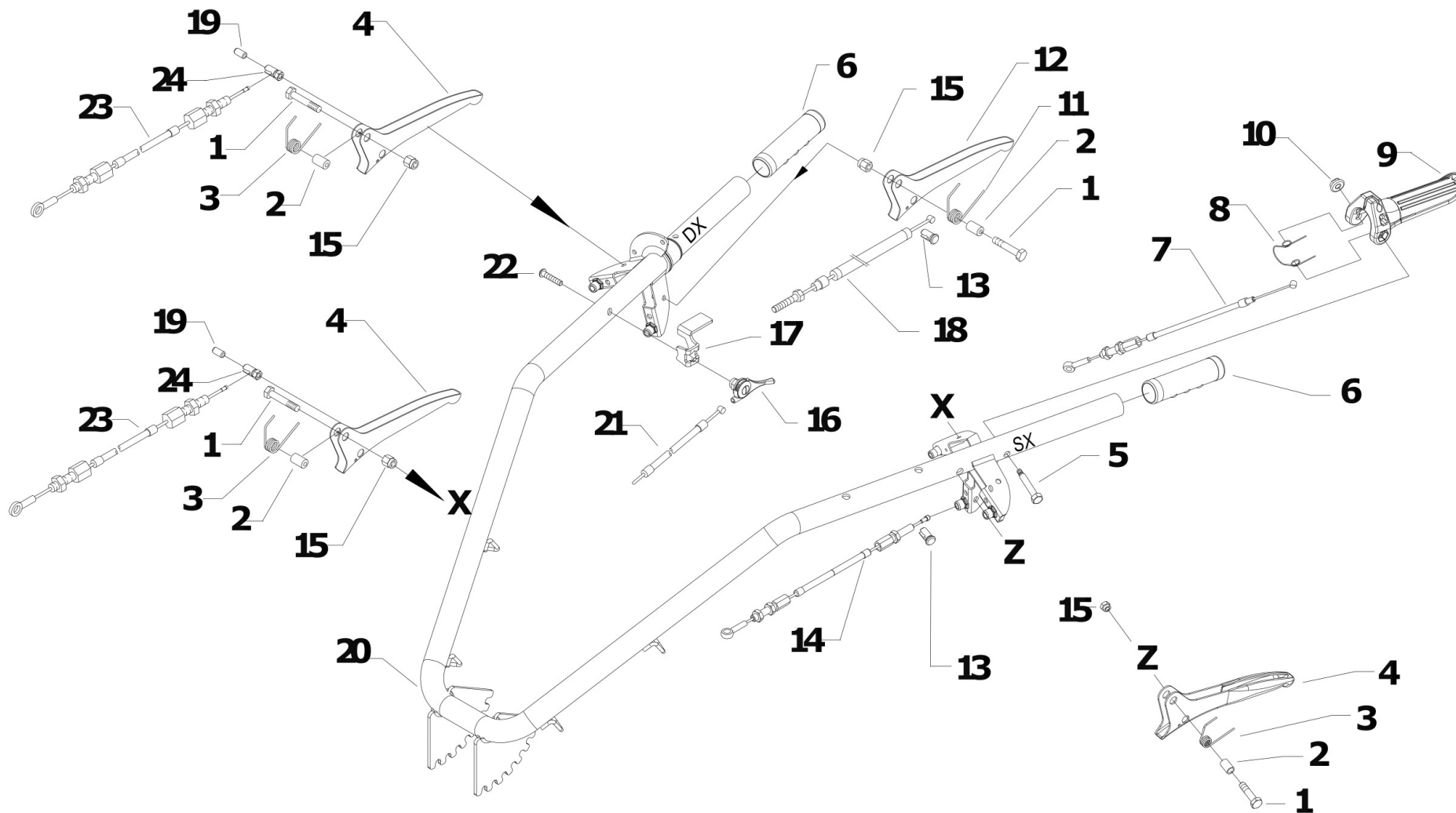

 [Click for info](#)

★ = new part



BCS Motor mowers, BCS 2-wheel tractors - 660 HY WS PS

K.01.02.A0028_00 - CONTROL LEVERS

Pos.	Id	Q.ty	Description	Note
1	31112089		SCREW TE M6X25 UNI 5739 8G	
2	56156603Z		SPACER	
3	58050345		SPRING	
4	56148470N		LEVER	
5	56356184Z		LEVER PIN	
6	58048000		KNOB D=27	
7	58056524		LINE L=1560	
8	58056186Z		SPRING	
9	55256185		LEVER	
10	31241065		SELFLOCK NUT M6	
11	58056605		SPRING	
12	56156604N		CLUTCH LEVER	
13	58150313		CABLE CLAMP	
14	58056523		LINE L=1490	
15	31241060		HEXAGON SELFLOCK NUT M6	
16	58002538		ACCELERATOR	
17	561C0131N		PANEL	
18	58057211		TRANSMISSION	
19	31100250		SCREW STEI M5X10 UNI 5923	
20	592C0141		MAN.MF WS ED PS IDRO CON P.I.	
21	58026222		LINE AND SHEATH (L=1380)	
21	58056812		LINE AND SHEATH L=1680	ENGINE EX35
22	31121020		SCREW TBCEI M8X40 ISO7380 10K Z	
23	58056580		TRANSMISSION	
24	561C0299Z		CABLE CLAMP D.8	
25	31100250		SCREW STEI M5X10 UNI 5923	



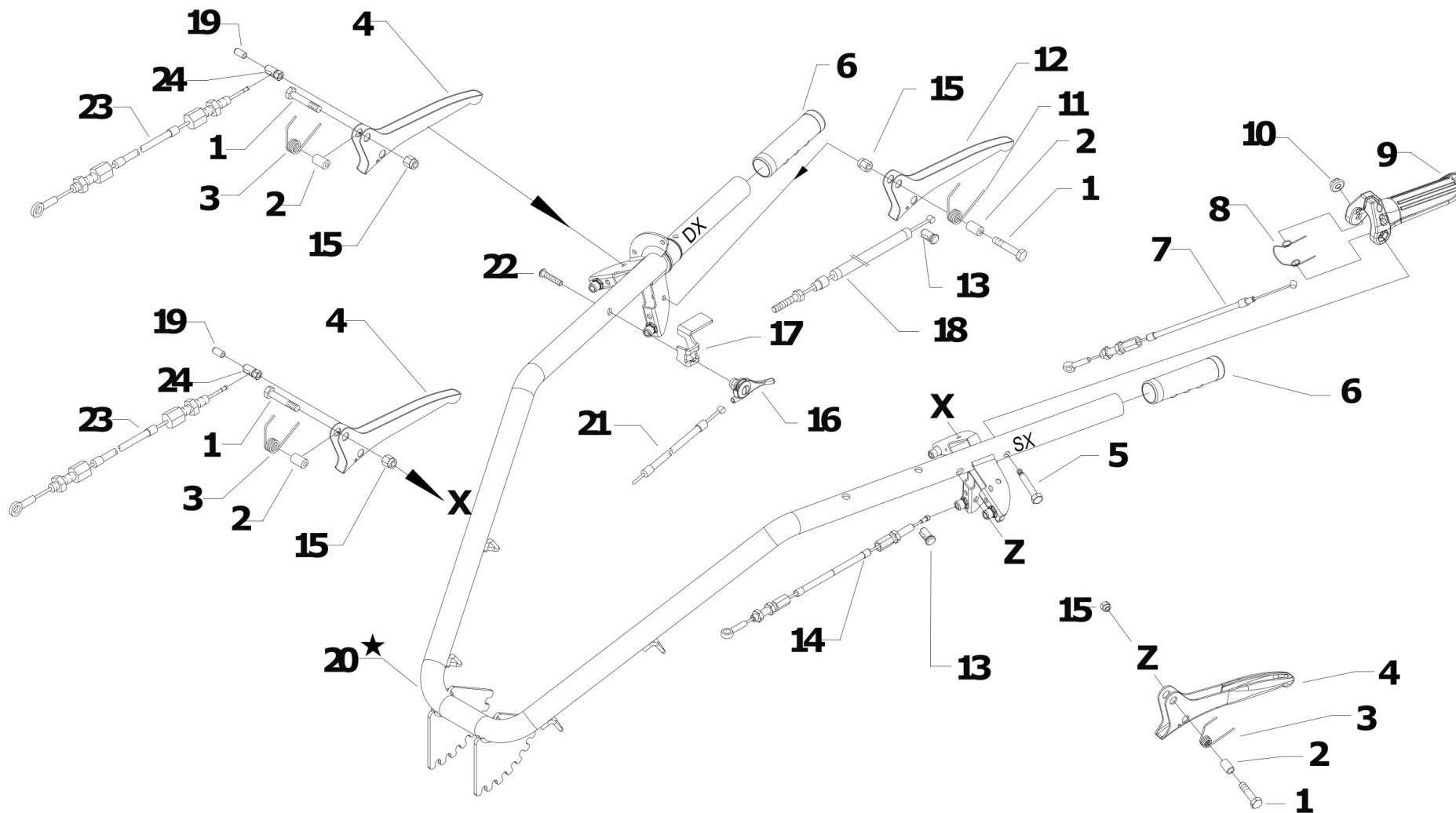

 [Click for info](#)

★ = new part



BCS Motor mowers, BCS 2-wheel tractors - 660 HY WS PS

K.01.02.A0028_02 - CONTROL LEVERS

Pos.	Id	Q.ty	Description	Note
1	31112089		SCREW TE M6X25 UNI 5739 8G	
2	56156603Z		SPACER	
3	58050345		SPRING	
4	56148470N		LEVER	
5	56356184Z		LEVER PIN	
6	58048000		KNOB D=27	
7	58056524		LINE L=1560	
8	58056186Z		SPRING	
9	55256185		LEVER	
10	31241065		SELFLOCK NUT M6	
11	58056605		SPRING	
12	56156604N		CLUTCH LEVER	
13	58150313		CABLE CLAMP	
14	58056523		LINE L=1490	
15	31241060		HEXAGON SELFLOCK NUT M6	
16	58002538		ACCELERATOR	
17	561C0131N		PANEL	
18	58057211		TRANSMISSION	
19	31100250		SCREW STEI M5X10 UNI 5923	
20	592C0141		MAN.MF WS ED PS IDRO CON P.I.	
20	592C1461		MAN. MF WS ED PS IDRO CON P.I.	EASYRIDER
21	58026222		LINE AND SHEATH (L=1380)	L100
21	58056812		LINE AND SHEATH L=1680	GX 390
21	580C0422		TRANSMISSION	B&S
22	31121020		SCREW TBCEI M8X40 ISO7380 10K Z	
23	58056580		TRANSMISSION	
24	561C0299Z		CABLE CLAMP D.8	
25	31100250		SCREW STEI M5X10 UNI 5923	



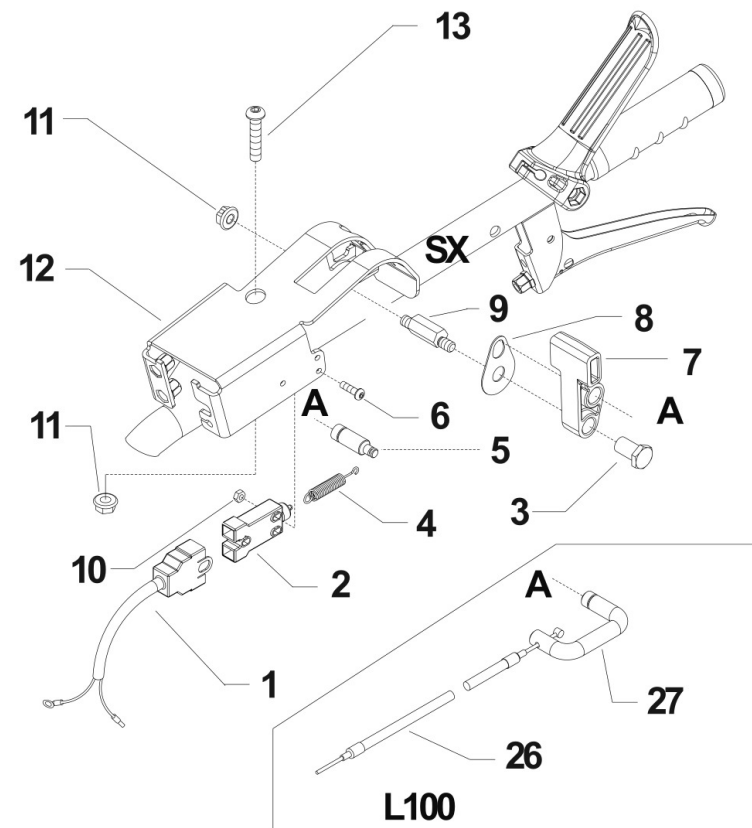
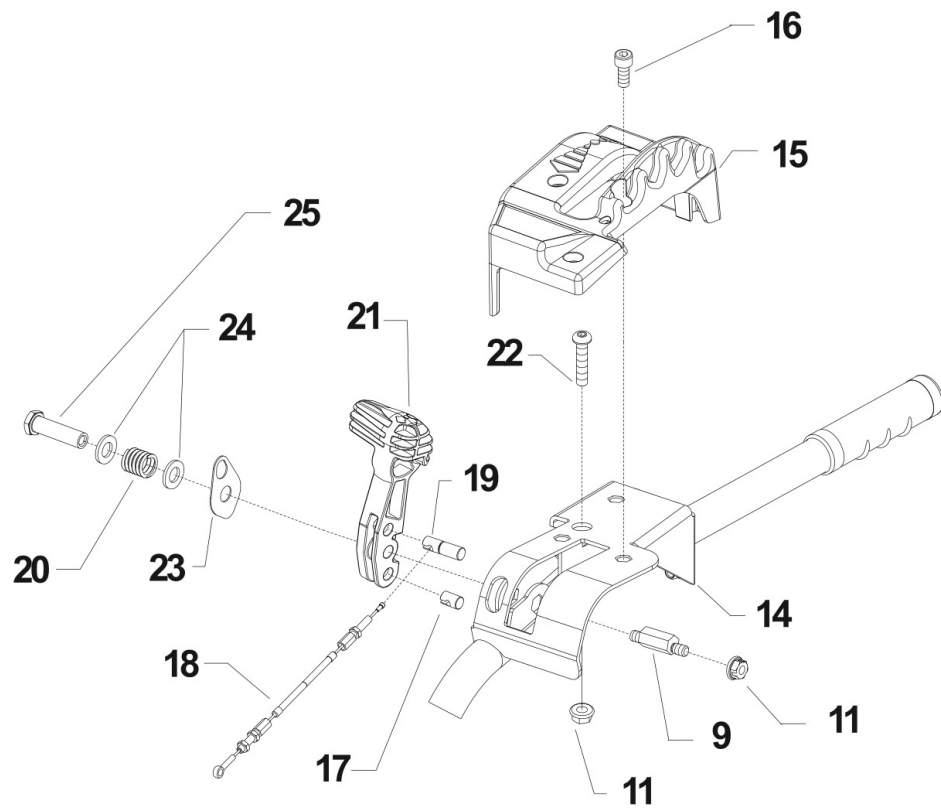

i = info - stop 2 sec. ★ = new part



Pos.	Id	Q.ty	Description	Note
1	58056837		WIRING	
2	58048009		ENGINE STOP SWITCH	
3	56148287		STUD BOLT	
4	58047712		SPRING	
5	56156834Z		INDEXING BOLT	
6	31121024		SCREW TBCEI FL.M4X25	
7	55256197		MOTOR STOP LEVER	
8	56356833Z		SMALL PLATE	
9	56356858Z		PIN	
10	31241042		SELFLOCK NUT M4 FL.6S	
11	31241084		SELFLOCK NUT M8 6S	
12	59256180		SUPPORT	
13	31121020		SCREW TBCEI M8X40 ISO7380 10K Z	
14	592C0211		SUPPORT	
15	552C0291		EASYGRIP CONTROL DEVICE	
16	31152081		SCREW TCEI M8X20 UNI 5931	
17	561C0216Z		CABLE CLAMP D.12	
18	580C0368		LINE AND SHEATH	
19	561C0217Z		CABLE CLAMP D12	
20	58025634Z		SPRING	
21	552C0195		COMMAND LEVER	
22	31121020		SCREW TBCEI M8X40 ISO7380 10K Z	
23	563C0215Z		SMALL PLATE	
24	31411130		WASHER 13x24	
25	561C0446Z		STUD BOLT	
26	58048005		LINE AND SHEATH (L=1170)	ENGINE L100
27	56156832Z		U BOLT	ENGINE L100



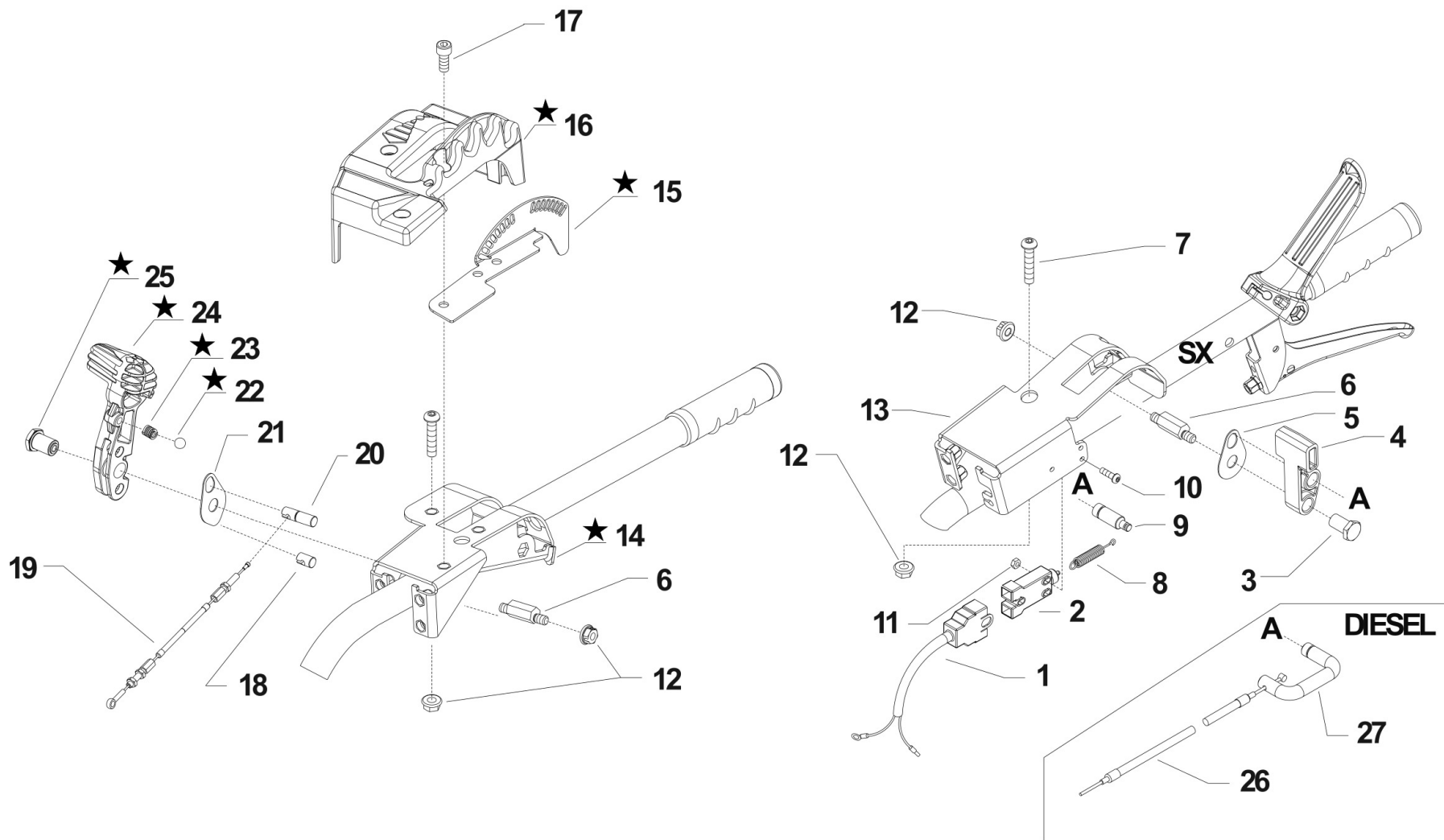

i = info - stop 2 sec. ★ = new part



Pos.	Id	Q.ty	Description	Note
1	58056837		WIRING	
2	58048009		ENGINE STOP SWITCH	
3	56148287		STUD BOLT	
4	55256197		MOTOR STOP LEVER	
5	56356833Z		SMALL PLATE	
6	56356858Z		PIN	
7	31121020		SCREW TBCEI M8X40 ISO7380 10K Z	
8	58047712		SPRING	
9	56156834Z		INDEXING BOLT	
10	31121024		SCREW TBCEI FL.M4X25	
11	31241042		SELFLOCK NUT M4 FL.6S	
12	31241084		SELFLOCK NUT M8 6S	
13	59256180		SUPPORT	
14	592C0477		SUPPORT	REPLACES 592C0211
15	561C0483Z		SECTOR	
16	552C0480		MANIPOLATORE EASYGRIP	REPLACES 552C0291
17	31152081		SCREW TCEI M8X20 UNI 5931	
18	561C0216Z		CABLE CLAMP D.12	
19	580C0368		LINE AND SHEATH	
20	561C0217		CABLE CLAMP D12	
21	563C0215Z		SMALL PLATE	
22	37911032		BALL 5/16	
23	58042059		SPRING	REPLACES 58025634Z
24	552C0484		COMMAND LEVER	REPLACES 552C0195
25	561C0476Z		STUD BOLT	REPLACES 561C0446Z
26	58048005		LINE AND SHEATH (L=1170)	L100
27	56156832Z		U BOLT	



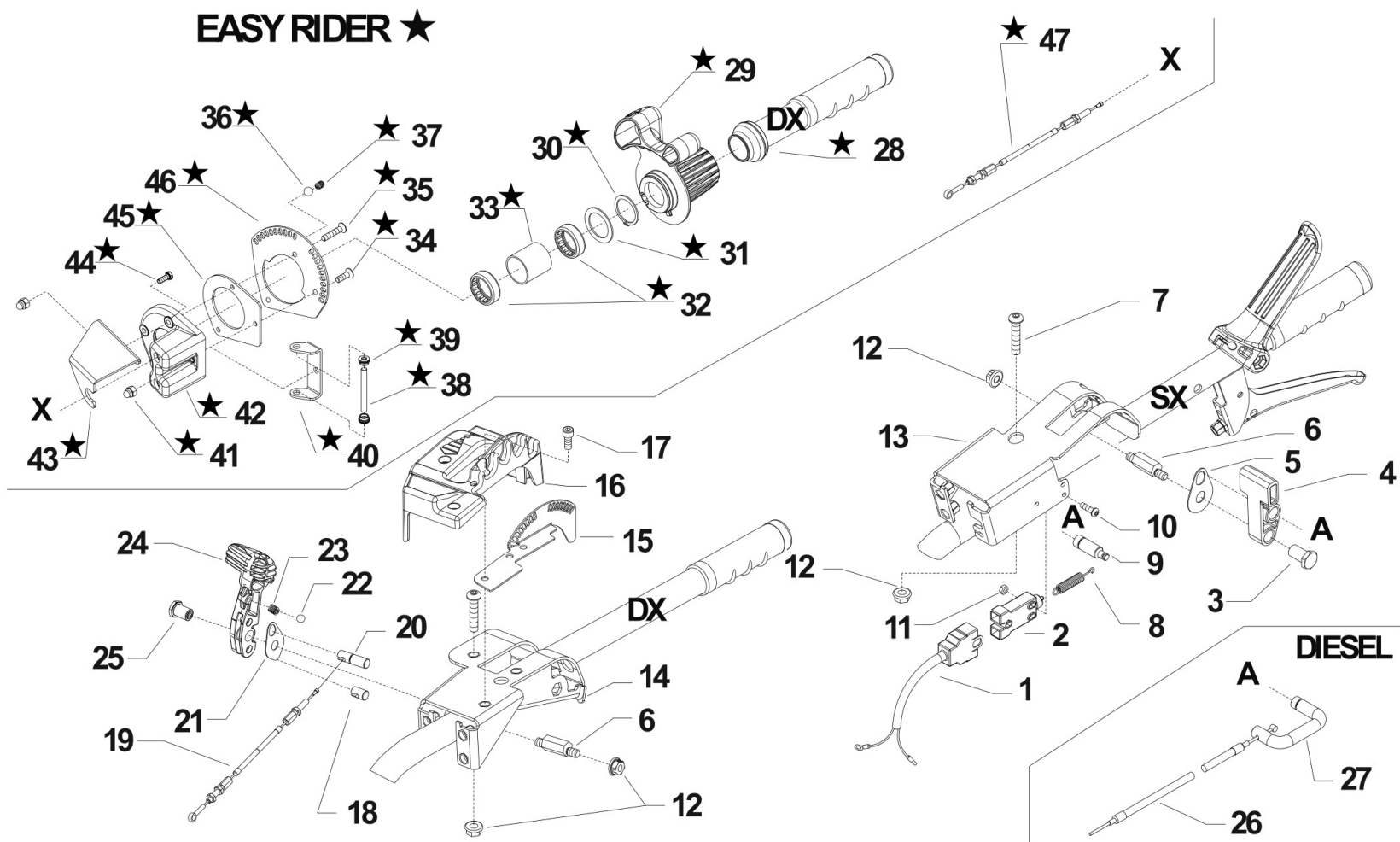

i = info - stop 2 sec. ★ = new part



BCS Motor mowers, BCS 2-wheel tractors - 660 HY WS PS

L.01.02.A0028_02 - HANDLEBAR CONTROLS

Pos.	Id	Q.ty	Description	Note
1	58056837		WIRING	
2	58048009		ENGINE STOP SWITCH	
3	56148287		STUD BOLT	
4	55256197		MOTOR STOP LEVER	
5	56356833Z		SMALL PLATE	
6	56356858Z		PIN	
7	31121020		SCREW TBCEI M8X40 ISO7380 10K Z	
8	58047712		SPRING	
9	56156834Z		INDEXING BOLT	
10	31121024		SCREW TBCEI FL.M4X25	
11	31241042		SELFLOCK NUT M4 FL.6S	
12	31241084		SELFLOCK NUT M8 6S	
13	59256180		SUPPORT	
14	592C0477		SUPPORT	
15	561C0483Z		SECTOR	
16	552C0480		MANIPOLATORE EASYGRIP	
17	31152081		SCREW TCEI M8X20 UNI 5931	
18	561C0216Z		CABLE CLAMP D.12	
19	580C0368		LINE AND SHEATH	
20	561C0217		CABLE CLAMP D12	
21	563C0215Z		SMALL PLATE	
22	37911032		BALL 5/16	
23	58042059		SPRING	
24	552C0484		COMMAND LEVER	
25	561C0476Z		STUD BOLT	
26	58048005		LINE AND SHEATH (L=1170)	L100
27	56156832Z		U BOLT	
28	552C1469		SLEEVE	
29	552C1468		MANIPOLATORE EASY RIDER	



Pos.	Id	Q.ty	Description	Note
30	35121030		SEEGER RING E 30 DIN 471	
31	31400192		SHIM PS 30x42/1,5	
32	37331303		BUSHING HK3012B AS1 30X37X12	
33	561C1465Z		SPACER	
34	31132516		SCREW TSVEI M5X16 UNI 5933	
35	31132525		SCREW TSVEI M5X25 UNI 5933	
36	37911032		BALL 5/16	
37	58042059		SPRING	
38	56457191		PIN	
39	55257197		CHAIN PULLEY	
40	56157178		SUPPORT	
41	31241053		SELFLOK M5 UNI 986 C/CALOT	
42	55257175		BODY	
43	561C1466N		PANEL	
44	31112051		SCREW TE M5X14 UNI 5739 8G	
45	561C1470Z		COVER	
46	561C1467Z		SECTOR	
47	580C1471		TRANSMISSION	



EASY RIDER

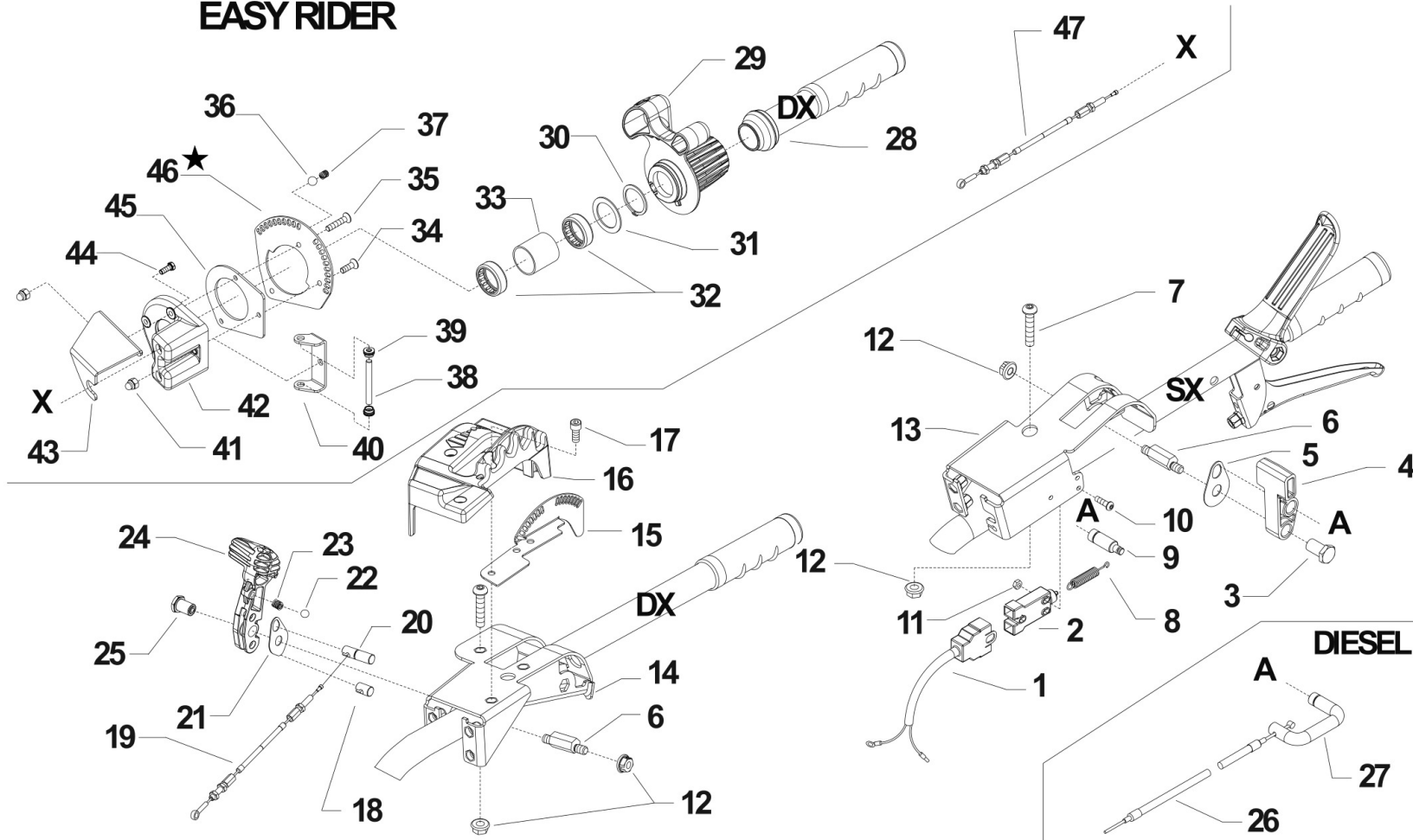

i = info - stop 2 sec. ★ = new part



BCS Motor mowers, BCS 2-wheel tractors - 660 HY WS PS

L.01.02.A0028_03 - HANDLEBAR CONTROLS

Pos.	Id	Q.ty	Description	Note
1	58056837		WIRING	
2	58048009		ENGINE STOP SWITCH	
3	56148287		STUD BOLT	
4	55256197		MOTOR STOP LEVER	
5	56356833Z		SMALL PLATE	
6	56356858Z		PIN	
7	31121020		SCREW TBCEI M8X40 ISO7380 10K Z	
8	58047712		SPRING	
9	56156834Z		INDEXING BOLT	
10	31121024		SCREW TBCEI FL.M4X25	
11	31241042		SELFLOCK NUT M4 FL.6S	
12	31241084		SELFLOCK NUT M8 6S	
13	59256180		SUPPORT	
14	592C0477		SUPPORT	
15	561C0483Z		SECTOR	
16	552C0480		MANIPOLATORE EASYGRIP	
17	31152081		SCREW TCEI M8X20 UNI 5931	
18	561C0216Z		CABLE CLAMP D.12	
19	580C0368		LINE AND SHEATH	
20	561C0217		CABLE CLAMP D12	
21	563C0215Z		SMALL PLATE	
22	37911032		BALL 5/16	
23	58042059		SPRING	
24	552C0484		COMMAND LEVER	
25	561C0476Z		STUD BOLT	
26	58048005		LINE AND SHEATH (L=1170)	L100
27	56156832Z		U BOLT	
28	552C1469		SLEEVE	
29	552C1468		MANIPOLATORE EASY RIDER	



Pos.	Id	Q.ty	Description	Note
30	35121030		SEEGER RING E 30 DIN 471	
31	31400192		SHIM PS 30x42/1,5	
32	37331303		BUSHING HK3012B AS1 30X37X12	
33	561C1465Z		SPACER	
34	31132516		SCREW TSVEI M5X16 UNI 5933	
35	31132525		SCREW TSVEI M5X25 UNI 5933	
36	37911032		BALL 5/16	
37	58042059		SPRING	
38	56457191		PIN	
39	55257197		CHAIN PULLEY	
40	56157178		SUPPORT	
41	31241053		SELFLOK M5 UNI 986 C/CALOT	
42	55257175		BODY	
43	561C1466N		PANEL	
44	31112051		SCREW TE M5X14 UNI 5739 8G	
45	561C1470Z		COVER	
46	563C1452Z		SETTORE ER ZNT	REPLACE 561C1467Z
47	580C1471		TRANSMISSION	



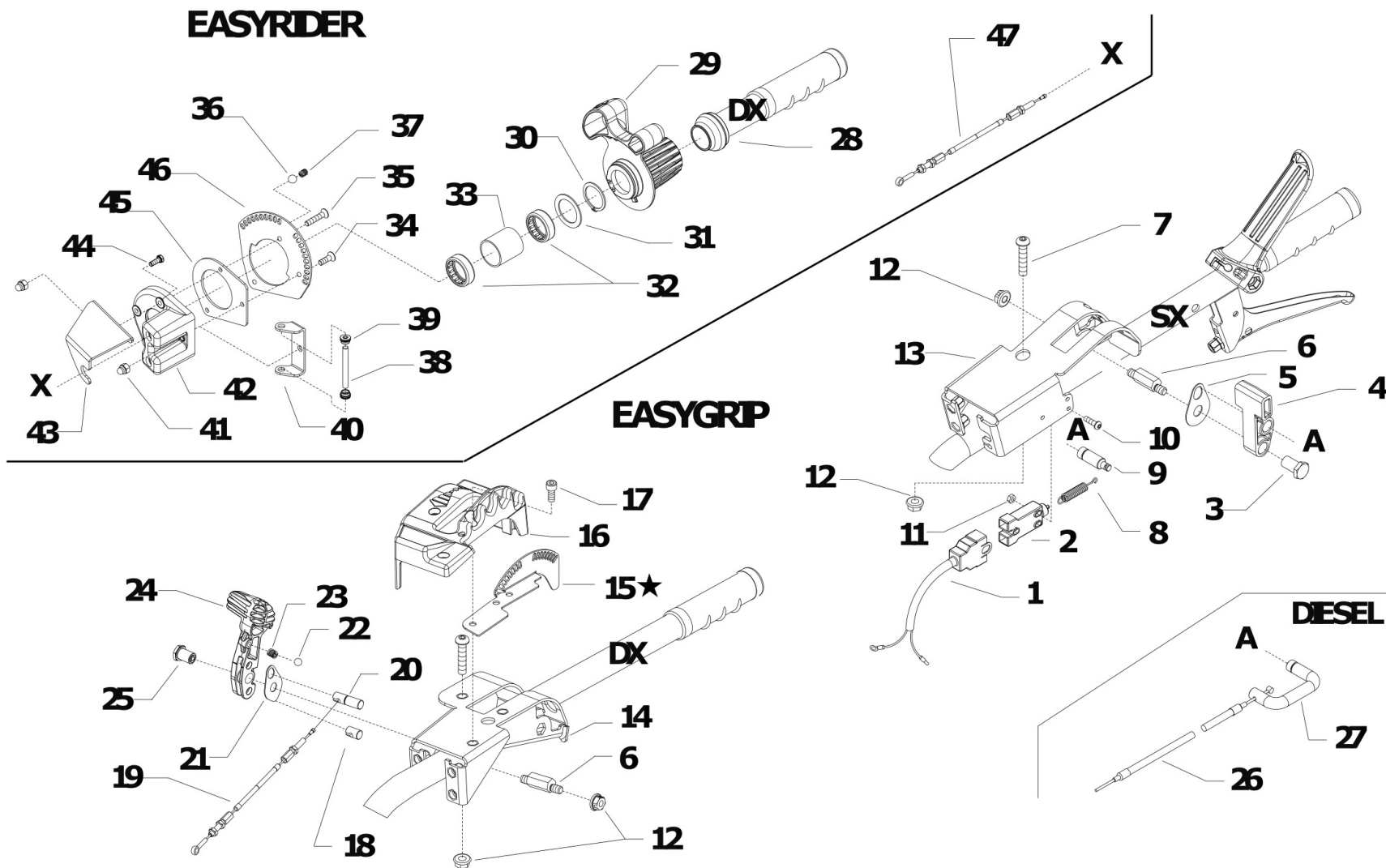

 [Click for info](#)

★ = new part



Pos.	Id	Q.ty	Description	Note
1	58056837		WIRING	
2	58048009		ENGINE STOP SWITCH	
3	56148287		STUD BOLT	
4	55256197		MOTOR STOP LEVER	
5	56356833Z		SMALL PLATE	
6	56356858Z		PIN	
7	31121020		SCREW TBCEI M8X40 ISO7380 10K Z	
8	58047712		SPRING	
9	56156834Z		INDEXING BOLT	
10	31121024		SCREW TBCEI FL.M4X25	
11	31241042		SELFLOCK NUT M4 FL.6S	
12	31241084		SELFLOCK NUT M8 6S	
13	59256180		SUPPORT	
14	592C0477		SUPPORT	
15	521C1453Z		SETTORE PER SFERA ZNT	REPLACE 561C0483Z
16	552C0480		MANIPOLATORE EASYGRIP	
17	31152081		SCREW TCEI M8X20 UNI 5931	
18	561C0216Z		CABLE CLAMP D.12	
19	580C0368		LINE AND SHEATH	
20	561C0217		CABLE CLAMP D12	
21	563C0215Z		SMALL PLATE	
22	37911032		BALL 5/16	
23	58042059		SPRING	
24	552C0484		COMMAND LEVER	
25	561C0476Z		STUD BOLT	
26	58048005		LINE AND SHEATH (L=1170)	L100
27	56156832Z		U BOLT	
28	552C1469		SLEEVE	
29	552C1468		MANIPOLATORE EASY RIDER	



Pos.	Id	Q.ty	Description	Note
30	35121030		SEEGER RING E 30 DIN 471	
31	31400192		SHIM PS 30x42/1,5	
32	37331303		BUSHING HK3012B AS1 30X37X12	
33	561C1465Z		SPACER	
34	31132516		SCREW TSVEI M5X16 UNI 5933	
35	31132525		SCREW TSVEI M5X25 UNI 5933	
36	37911032		BALL 5/16	
37	58042059		SPRING	
38	56457191		PIN	
39	55257197		CHAIN PULLEY	
40	56157178		SUPPORT	
41	31241053		SELFLOK M5 UNI 986 C/CALOT	
42	55257175		BODY	
43	561C1466N		PANEL	
44	31112051		SCREW TE M5X14 UNI 5739 8G	
45	561C1470Z		COVER	
46	563C1452Z		SETTORE ER ZNT	
47	580C1471		TRANSMISSION	



BCS Motor mowers, BCS 2-wheel tractors - 660 HY WS PS

L.01.02.A0028_04 - HANDLEBAR CONTROLS

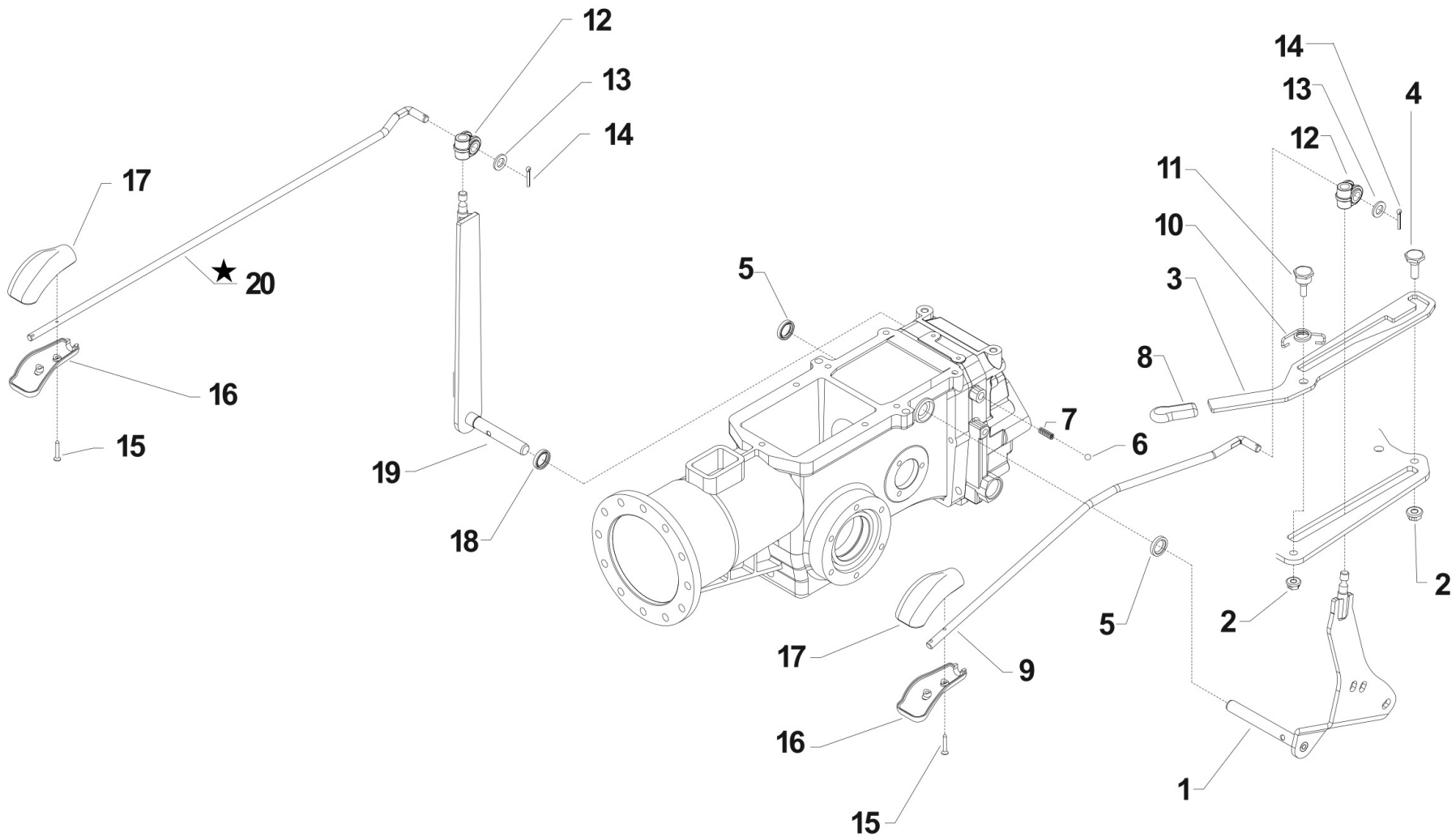

i = info - stop 2 sec. ★ = new part



BCS Motor mowers, BCS 2-wheel tractors - 660 HY WS PS

M.01.02.A0028_01 - AUCTION OF CONTROL

Pos.	Id	Q.ty	Description	Note
1	590C0186N		GEAR LEVER	
2	31241084		SELFLOCK NUT M8 6S	
3	561C0228Z		LEVER	
4	563C0426Z		LOCKING BOLT	
5	38211400		OIL SEAL 14X22X4	
6	37911532		BALL 15/32	
7	58043176		SPRING	
8	F0828468050		HANDLE	
9	561C0132Z		PULL ROD	
10	580C0133Z		SPRING	
11	563C0134Z		PIN	
12	55242528		JOINT	
13	31411104		WASHER 10,5x18	
14	34110028		SPLIT PIN A3X15 UNI 1336	
15	31100451		SCREW 3,5X25	
16	55157213		GRIP	
17	55157212		GRIP	
18	38211496		OIL SEAL AS15X26X7 DIN3760 NBR	
19	590C0270N		PTO LEVER	
20	561C0127Z		ROD	REPLACES 56157367Z

