

FERRARI

FERRARI Motor mowers, FERRARI 2-wheel tractors



A50010 - 518 PS.....	3
A.01.02.A0042_00 - ENGINE GUARDS.....	7
B.01.01.A0039_00 - POWERSAFE CLUCH CONTROL.....	9
B.01.01.A0039_01 - POWERSAFE CLUCH CONTROL.....	11
C.01.01.A0039_00 - CYLINDER AND POWERSAFE CLUTCH.....	13
D.01.02.A0042_00 - POWERSAFE FILTER AND UNIT.....	15
E.01.02.A0041_00 - POWERSAFE CLUTCH HUB.....	17
F.01.02.A0041_00 - ENGINE FLANGES.....	19
G.01.02.A0041_00 - GEARBOX.....	21
H.02.02.A0041_00 - GEARS.....	23
I.03.02.A0041_00 - WHEEL AXLE.....	26
J.02.02.A0041_00 - STEERING COLUMN.....	29
J.02.02.A0041_01 - STEERING COLUMN.....	31
K.02.02.A0041_00 - HANDLEBAR.....	33
L.02.02.A0041_00 - HANDLEBAR CONTROLS.....	35
L.02.02.A0041_01 - HANDLEBAR CONTROLS.....	37
M.02.02.A0041_00 - CONTROLS.....	39
M.02.02.A0041_01 - CONTROLS.....	41
P.01.02.A0041_00 - STICKERS.....	44
P.02.02.A0042_00 - STICKERS.....	46
R.01.02.A0041_00 - WHEELS.....	48



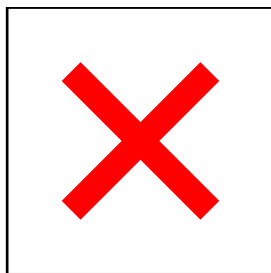



Id	Description
A.01.02.A0042_00	ENGINE GUARDS
B.01.01.A0039_00	POWERSAFE CLUCH CONTROL
B.01.01.A0039_01	POWERSAFE CLUCH CONTROL
C.01.01.A0039_00	CYLINDER AND POWERSAFE CLUTCH
D.01.02.A0042_00	POWERSAFE FILTER AND UNIT
E.01.02.A0041_00	POWERSAFE CLUTCH HUB
F.01.02.A0041_00	ENGINE FLANGES
G.01.02.A0041_00	GEARBOX
H.02.02.A0041_00	GEARS
I.03.02.A0041_00	WHEEL AXLE
J.02.02.A0041_00	STEERING COLUMN
J.02.02.A0041_01	STEERING COLUMN
K.02.02.A0041_00	HANDLEBAR
L.02.02.A0041_00	HANDLEBAR CONTROLS
L.02.02.A0041_01	HANDLEBAR CONTROLS
M.02.02.A0041_00	CONTROLS
M.02.02.A0041_01	CONTROLS
P.01.02.A0041_00	STICKERS
P.02.02.A0042_00	STICKERS
R.01.02.A0041_00	WHEELS

Id	Description
A.01.02.A0042_00	ENGINE GUARDS
B.01.01.A0039_00	POWERSAFE CLUCH CONTROL
B.01.01.A0039_01	POWERSAFE CLUCH CONTROL
C.01.01.A0039_00	CYLINDER AND POWERSAFE CLUTCH
D.01.02.A0042_00	POWERSAFE FILTER AND UNIT
E.01.02.A0041_00	POWERSAFE CLUTCH HUB
F.01.02.A0041_00	ENGINE FLANGES



Id	Description
G.01.02.A0041_00	GEARBOX
H.02.02.A0041_00	GEARS
I.03.02.A0041_00	WHEEL AXLE
J.02.02.A0041_00	STEERING COLUMN
J.02.02.A0041_01	STEERING COLUMN
K.02.02.A0041_00	HANDLEBAR
L.02.02.A0041_00	HANDLEBAR CONTROLS
L.02.02.A0041_01	HANDLEBAR CONTROLS
M.02.02.A0041_00	CONTROLS
M.02.02.A0041_01	CONTROLS
P.01.02.A0041_00	STICKERS
P.02.02.A0042_00	STICKERS
R.01.02.A0041_00	WHEELS

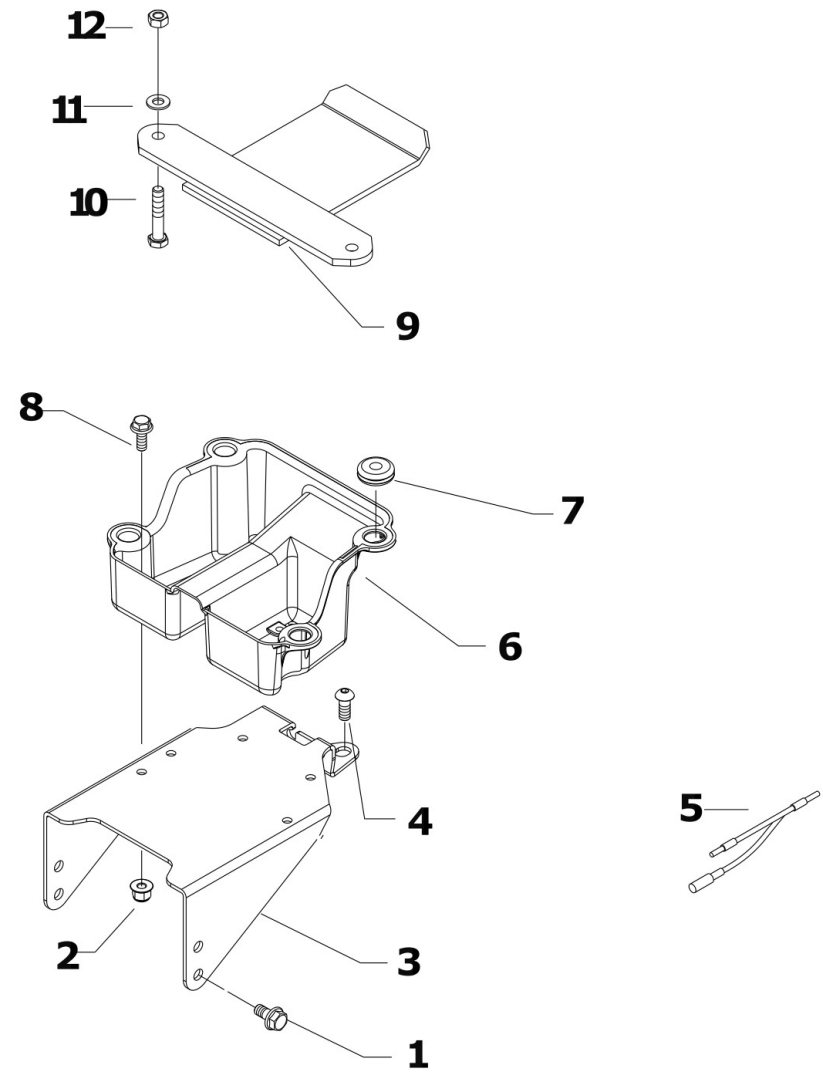
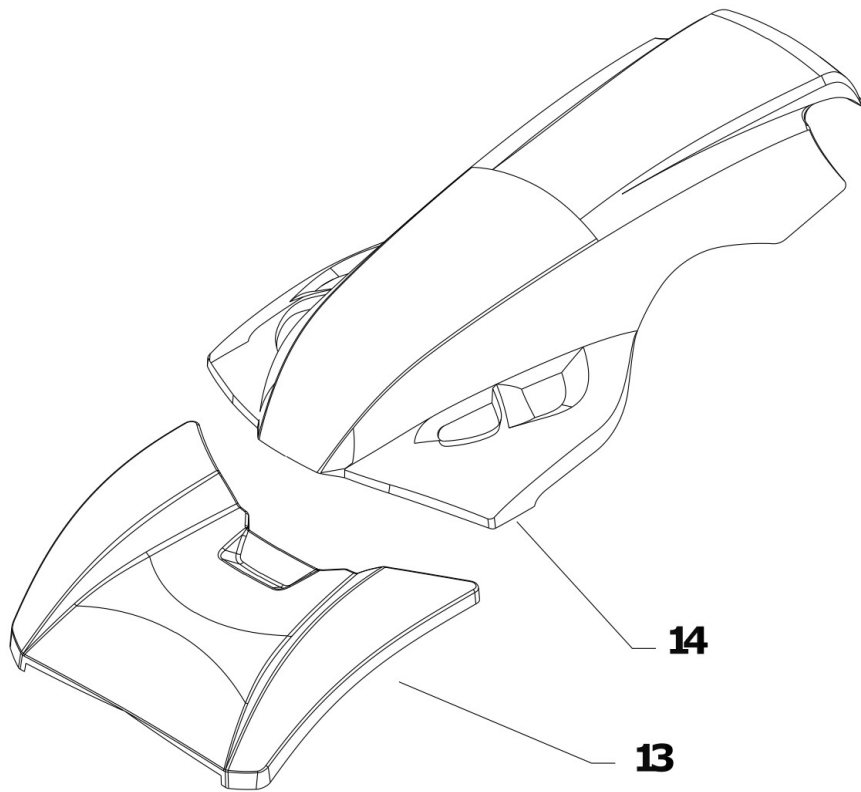

 [Click for info](#)

★ = new part

Pos.	Id	Q.ty	Description	Note
1	31112171		SCREW TE C/F M8X16 DIN 6921	
2	31241066		SELFLOCK M6 FL NY DIN 6926	
3	56156246N		TUNNEL	
4	31121008		SCREW TBCEI M10X16 ISO 7380	
5	58057385		LINE	
6	552C1001		FAIRINGS BOX	
7	58056991		CABLE GLAND 90/200/30	
8	31112081		SCREW TE C/F M6X20 DIN 6921 8G	
9	56156119N		SHIELD	GX270
9	59056051N		SHIELD	KD350
9	59056089N		SHIELD	GP160 - GX200
9	59056111N		SHIELD	L100
10	31112169		SCREW TE C/F M8X40 DIN 6921	
10	31112213		SCREW TE M10X40 UNI 5739	KD350
11	31411104		WASHER 10,5x18	KD350
12	31241084		SELFLOCK NUT M8 6S	
12	31241100		SELFLOCK HEXAGON NUT M10	KD350
13	55252406		GUARD BATTERY BOX	
14	55252405		GUARD	



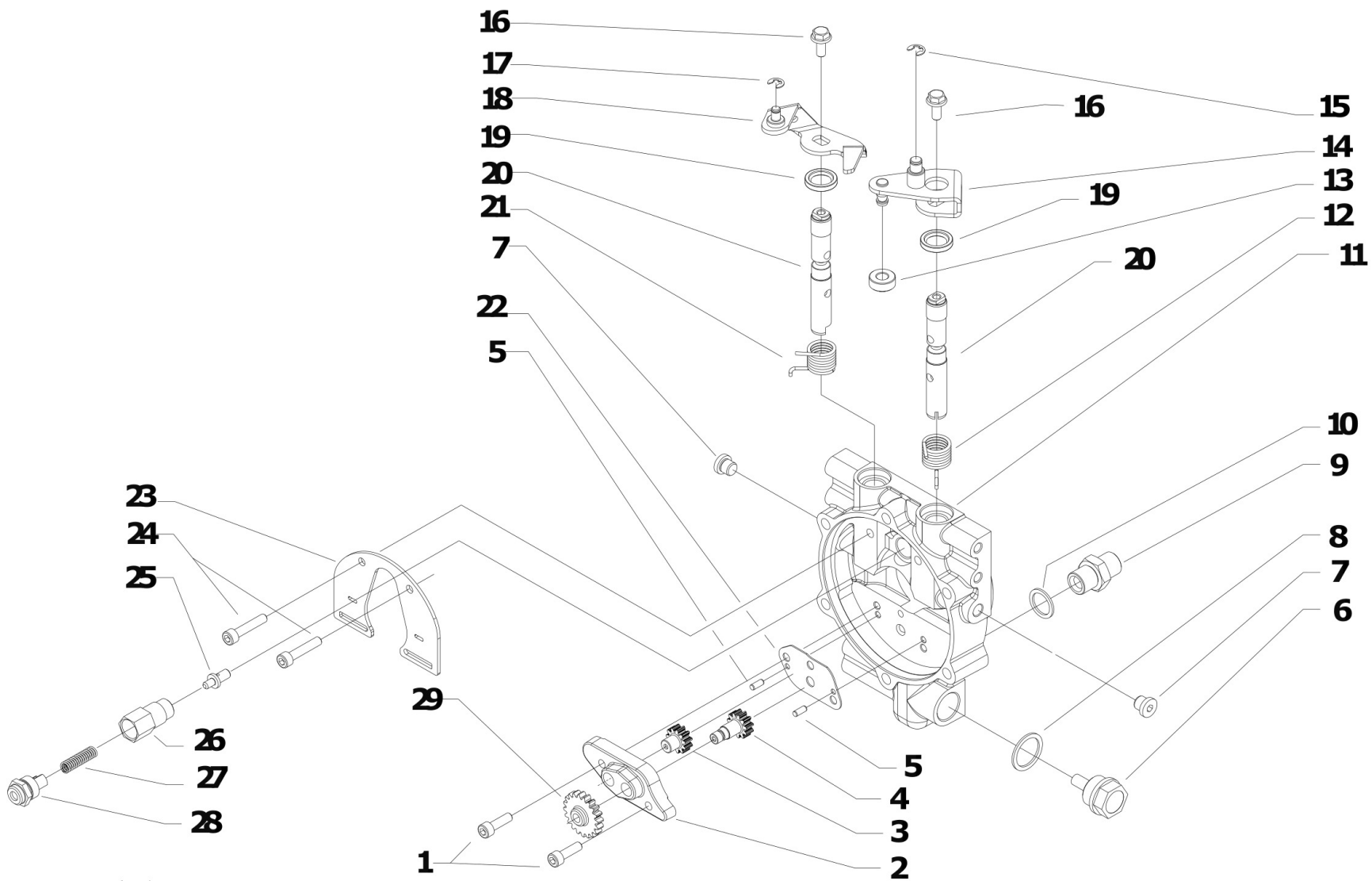

 [Click for info](#)

★ = new part

Pos.	Id	Q.ty	Description	Note
1	31152063		SCREW TCEI M6X20 UNI 5931	
2	56356364		PUMP COVER PS/14	
3	52456371		PUMP GEAR PS/14	
4	52456372		PUMP GEAR	
5	34221040		CYLINDRICAL PLUG	
6	58170021		PLUG	
7	580C0041		PLUG	
8	F0844273090		GASKET 22X28X1,5 CU 99,5	
9	30000197		NIPPLE	
10	31480184		COPPER WASHER 16,7x22/1,5	
11	59256745		POWERSAFE CLUTCH FLANGE	
12	58056222		SPRING	
13	55256228		ROLLER	
14	59056225Z		CLUTCH LEVER	
15	35211060		SEEGER RING E 6 UNI 7434	
16	31112084		SCREW TE C/F M6X14 DIN 6921 8G	
17	35211050		SEEGER RING E 5 UNI 7434	
18	59056748Z		COMPLETE STOP LEVER PS GALV.	
19	38211400		OIL SEAL 14X22X4	
20	52456220		DISTRIBUTOR	
21	58056221		SPRING	
22	56356747		PUMP RECEPTOR PS/14	
23	56156224		SHIELD	
24	31152060		SCREW TCEI M6X30 UNI 5931	
25	56456657		VALVE	
26	56156658		VALVE INSERT/INLET	
27	58056683		SPRING	
28	56356242		PLUG	
29	52456235		PUMP GEAR	



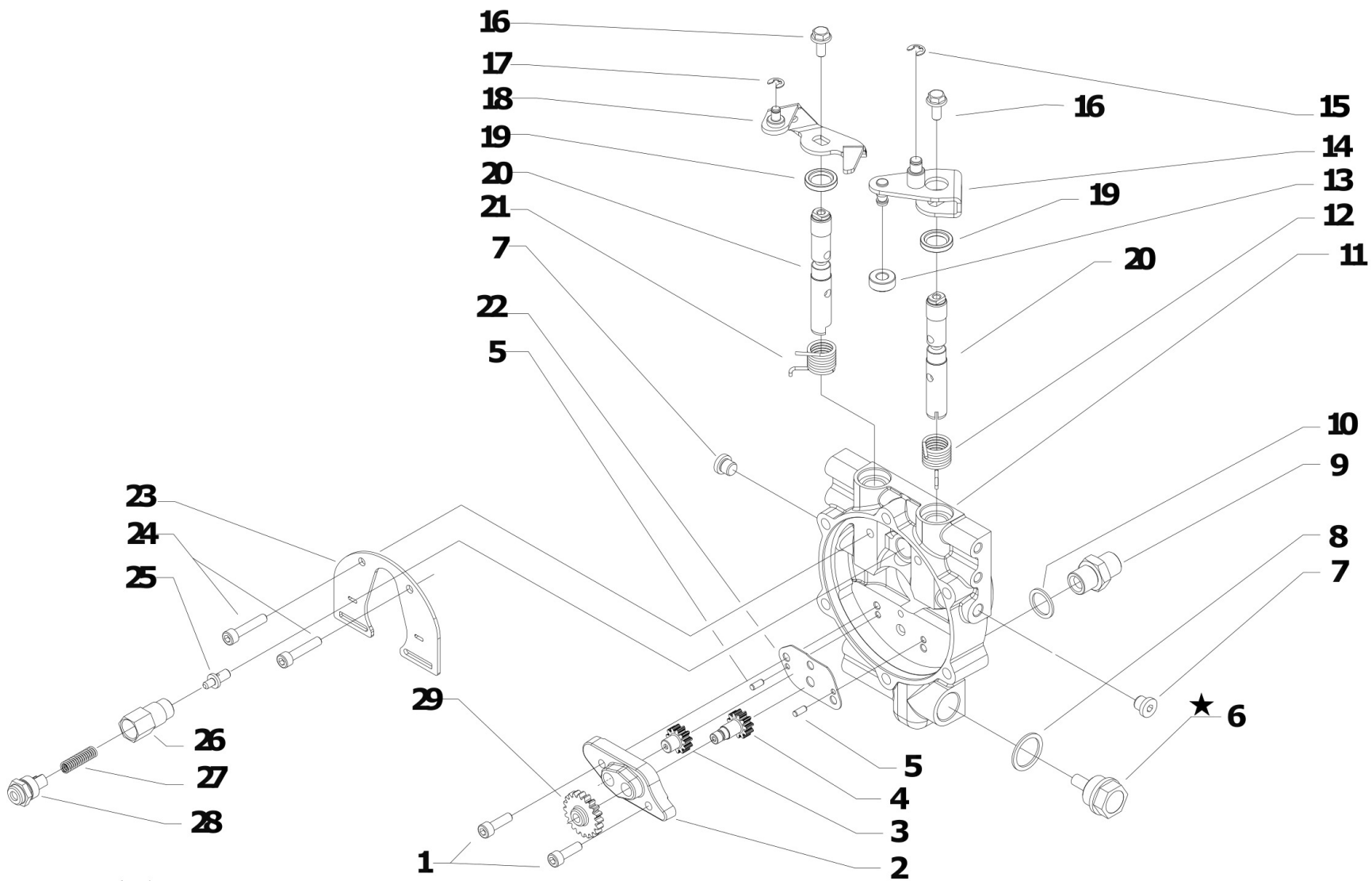

 [Click for info](#)

★ = new part

Pos.	Id	Q.ty	Description	Note
1	31152063		SCREW TCEI M6X20 UNI 5931	
2	56356364		PUMP COVER PS/14	
3	52456371		PUMP GEAR PS/14	
4	52456372		PUMP GEAR	
5	34221040		CYLINDRICAL PLUG	
6	581C2554		TAPPO MAGNETICO M22X1,5	
7	580C0041		PLUG	
8	F0844273090		GASKET 22X28X1,5 CU 99,5	
9	30000197		NIPPLE	
10	31480184		COPPER WASHER 16,7x22/1,5	
11	59256745		POWERSAFE CLUTCH FLANGE	
12	58056222		SPRING	
13	55256228		ROLLER	
14	59056225Z		CLUTCH LEVER	
15	35211060		SEEGER RING E 6 UNI 7434	
16	31112084		SCREW TE C/F M6X14 DIN 6921 8G	
17	35211050		SEEGER RING E 5 UNI 7434	
18	59056748Z		COMPLETE STOP LEVER PS GALV.	
19	38211400		OIL SEAL 14X22X4	
20	52456220		DISTRIBUTOR	
21	58056221		SPRING	
22	56356747		PUMP RECEPTOR PS/14	
23	56156224		SHIELD	
24	31152060		SCREW TCEI M6X30 UNI 5931	
25	56456657		VALVE	
26	56156658		VALVE INSERT/INLET	
27	58056683		SPRING	
28	56356242		PLUG	
29	52456235		PUMP GEAR	



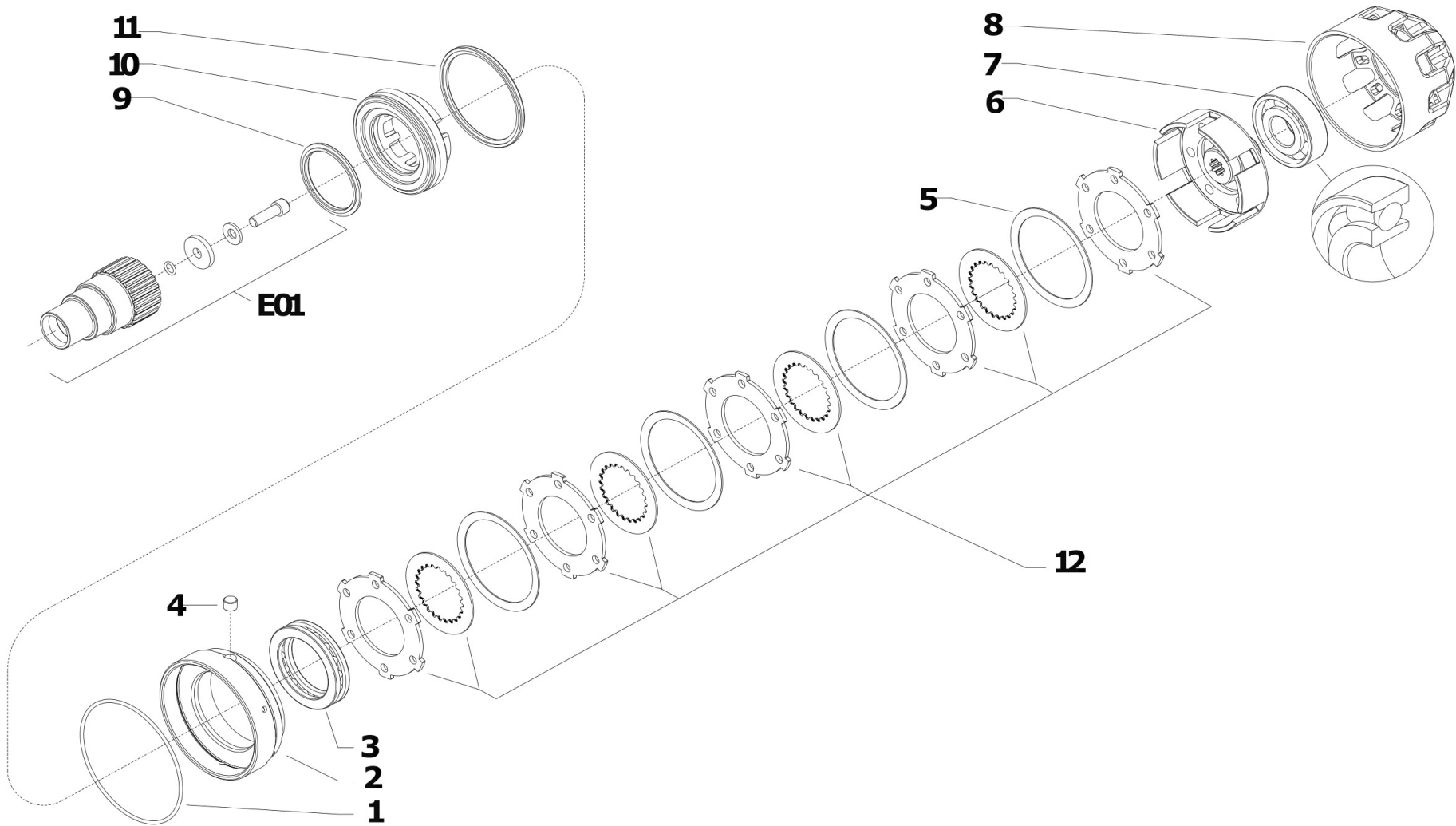

 [Click for info](#)

★ = new part

Pos.	Id	Q.ty	Description	Note
1	38118859		O-RING OR 3375 (94,92X2,62)	
2	56356216		RING	
3	37161500		BEARING 51110 (50X70X14)	
4	56156247		PIN	
5	56556213		SPRING	nr.4
6	52456694		CLUTCH HOUSING	
7	37141253		BEARING 7305-BJP OBL 25x62x17	
8	53156210		SUMP	
9	38120501		RING PTFE PRP 01A02-0500-A-32	
10	53156218		PISTON	
11	38140851		RING PTFE PRP02A02-0850-A-32-N	
12	59256693		9 DISC CLUTCH	



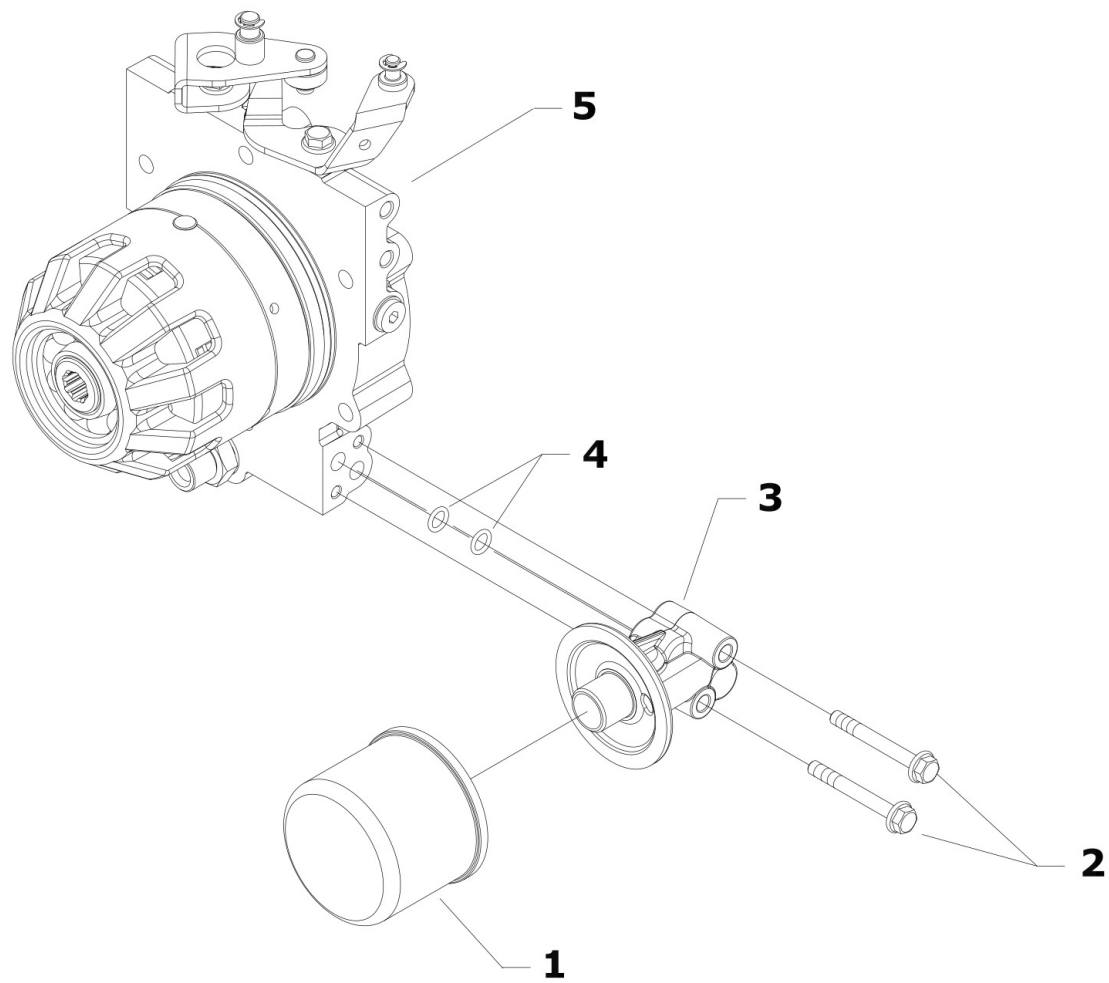

 [Click for info](#)

★ = new part

Pos.	Id	Q.ty	Description	Note
1	58056208		HYDRAULIC OIL FILTER	
2	31112099		SCREW TE C/F M6X50 DIN 6921 8G	
3	53156209		CONNECTION	
4	38110873		O-RING 108 (8,73X1,78)	
5	59256035		POWERSAFE CLUTCH ASSY Q19	GP160 - GX200
5	59256036		POWERSAFE CLUTCH	GX270
5	59256037		CLUTCH FOR POWERSAFE Q25.4 (3/8)	GX340
5	59256038		POWERSAFE CLUTCH	KD350 - L100



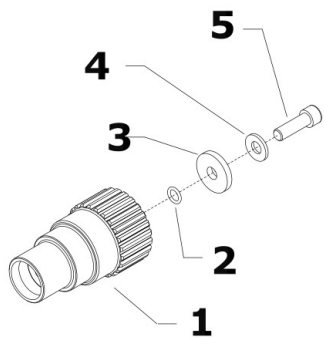

GP160-GX200

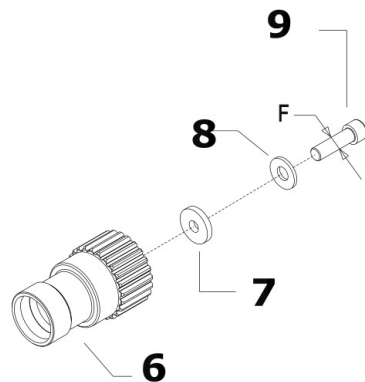

GX270-340 F-38'-24X1''-UNF

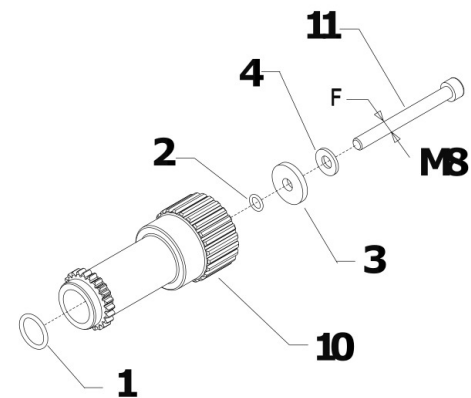

KD350-L100

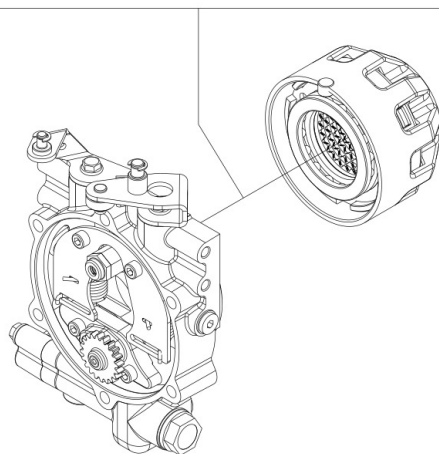

i = info - stop 2 sec. ★ = new part

Pos.	Id	Q.ty	Description	Note
1	52456234		HUB Q19	
2	38110675		O-RING 106 (6,75X1,78)	
3	56156288Z		SPECIAL WASHER SP.4	
4	31421083		WASHER	
5	31100023		SCREW 5/16-24 X 1 UNF 8G	
6	52456233		HUB Q25	
7	56156743		WASHER 30X11.5X3	GX270
7	561C0421		WASHER	GX340
8	31421101		WASHER 10 DIN 679	GX340
8	31421130		WASHER	GX270
9	31100032		SCREW TCCEI 7/16-20 X 1-1/2	GX270
9	31100033		SCREW TCCEI 3/8-24 X 1-1/2	GX340
10	52456245		HUB	
11	31152090		SCREW TCEI M8x80 UNI5931	



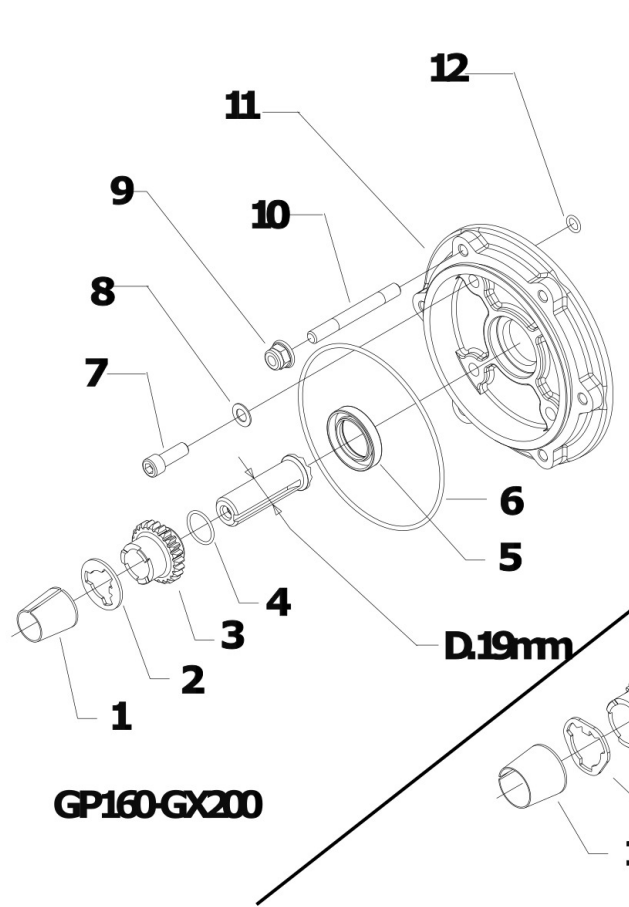

GP160-GX200

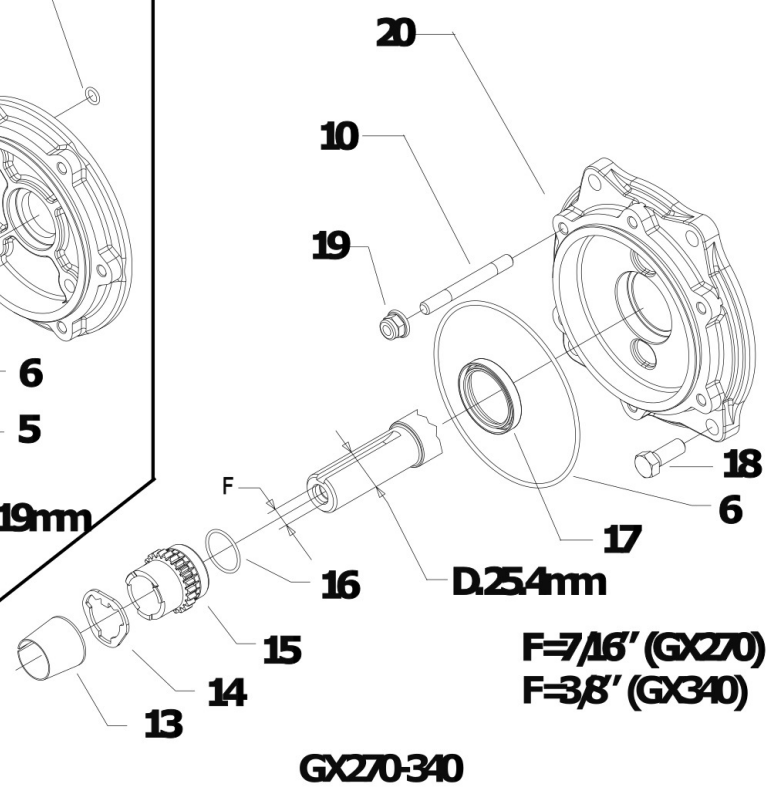

GX270-340
 F=7/16" (GX270)
 F=3/8" (GX340)

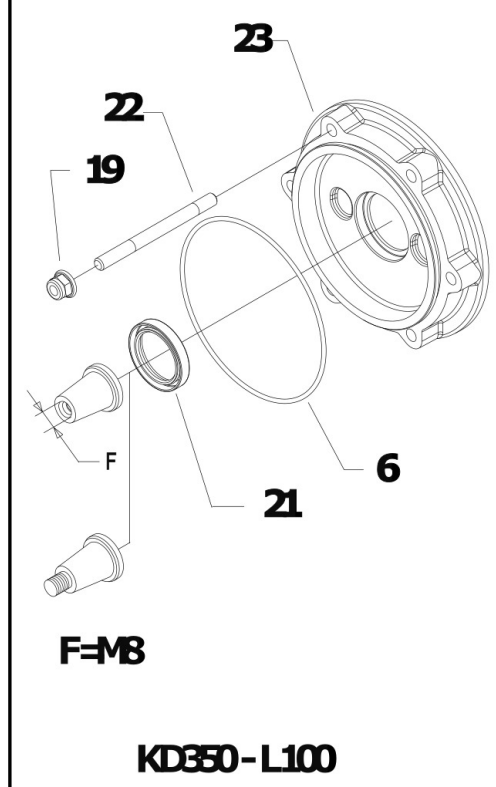

KD350-L100
 F=M8

 [Click for info](#)

★ = new part



Pos.	Id	Q.ty	Description	Note
1	56156276		SLEEVE D.19	
2	56356240		TRANSMISSION	
3	52456237		PUMP GEAR	
4	F0803067000		O-RING 2075 (18,77X1,78)	
5	38212500		OIL SEAL 25X40X7	
6	38119823		O-RING 3450 (113,97x2,62)	
7	31104022		SCREW TCEI 5/16X7/8 UNF 12K	
8	31423084		SPRING WASHER 8,4	
9	31241083		SELFLOCK NUT M8	
10	31312073		STUD BOLT M8X73X14X20 8G	
11	53156206		ENGINE FLANGE Q19	
12	38110873		O-RING 108 (8,73X1,78)	
13	56156281		CENTRING BUSH D.25,4	
14	56356239		FEEDER Q25	
15	52456236		PUMP GEAR	
16	F0803075500		O-RING 2100 (25,12X1,78)	
17	38213500		OIL SEAL 35X47X7	
18	31100015		SCREW TE 3/8X1	
19	31241083		SELFLOCK NUT M8	
20	53156205		ENGINE FLANGE Q25	
21	38213202		OIL SEAL 32X45X7	
22	31312097		STUD BOLT M8X98X16X28 8G	
23	53156207		ENGINE FLANGE	



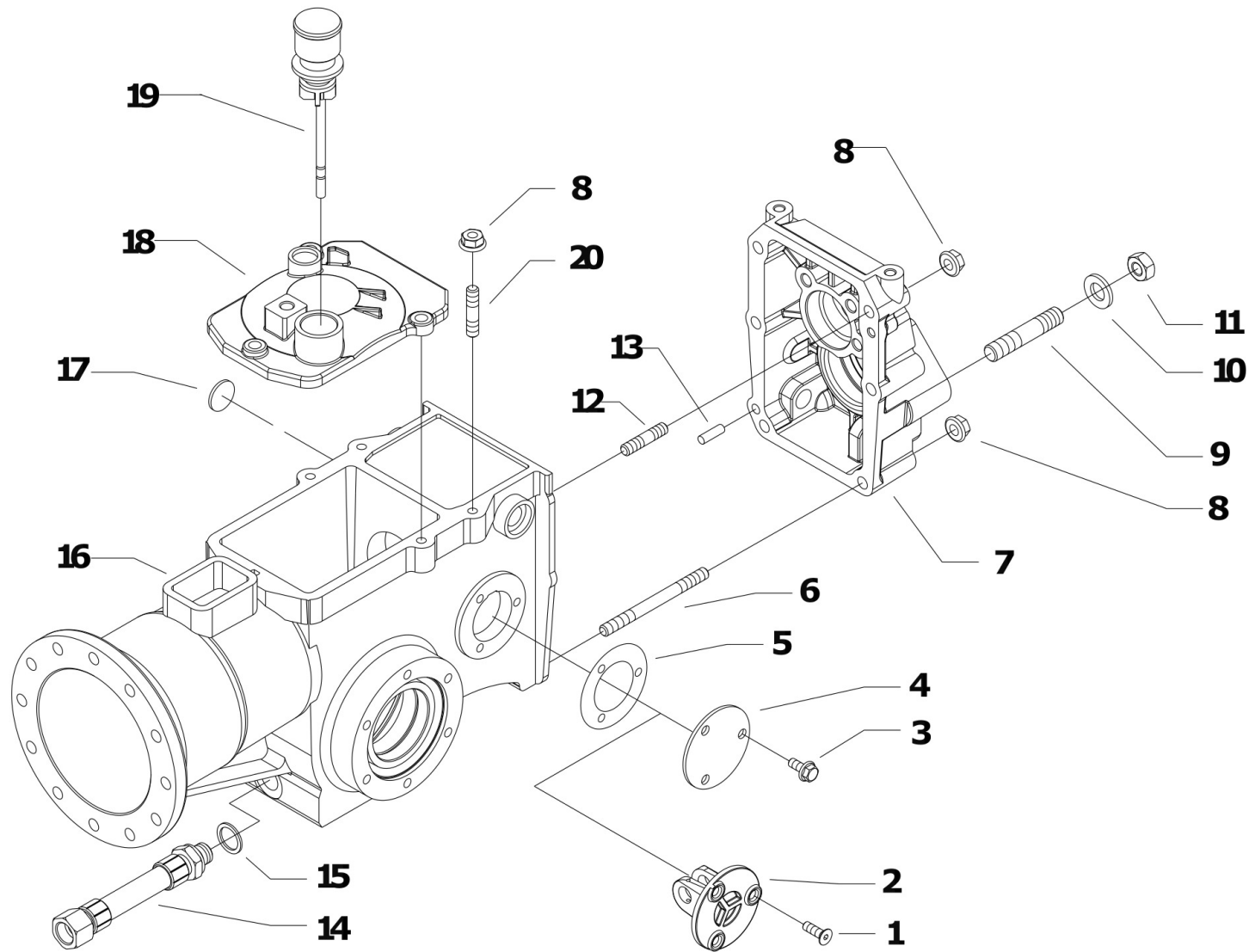

 [Click for info](#)

★ = new part

Pos.	Id	Q.ty	Description	Note
1	31132568		VITE TSVEI M6X16 DIN 7991 RSV	
2	53156342N		GEAR SUPPORT	
3	31112079		VITE TE C/F M6X12 DIN 6921 RVS	
4	56147520Z		COVER	
5	58056447		GASKET	
6	31312094		STUD BOLT M8X68X14X36	
7	53156332N		REAR COVER	
8	31241084		SELFLOCK NUT M8 6S	
9	31312124		STUD BOLT 52XM12X1,25X22XM12X22 8G	614
9	31312125		STUD BOLT 64XM12X1,25X26XM12X30 8G	615 - 618
10	31421132		WASHER 13X24X2,8	
11	31221121		NUT M12X1,25	
12	31312086		STUD BOLT M8X56X20X14	
13	58043053		CYLINDRICAL PLUG	
14	59056248		SUCTION SHORT HOSE	
15	31480184		COPPER WASHER 16,7x22/1,5	
16	53156203N		BOX CASING	
17	30040133Z		PLUG 22 DIN 470	614
18	53143128N		COVER	614 - 615
18	53143875N		GEARBOX HOUSING COVER	618
19	59256762		OIL CAP M COMPLETE	
20	31312082		STUD BOLT M8X38X14X20	



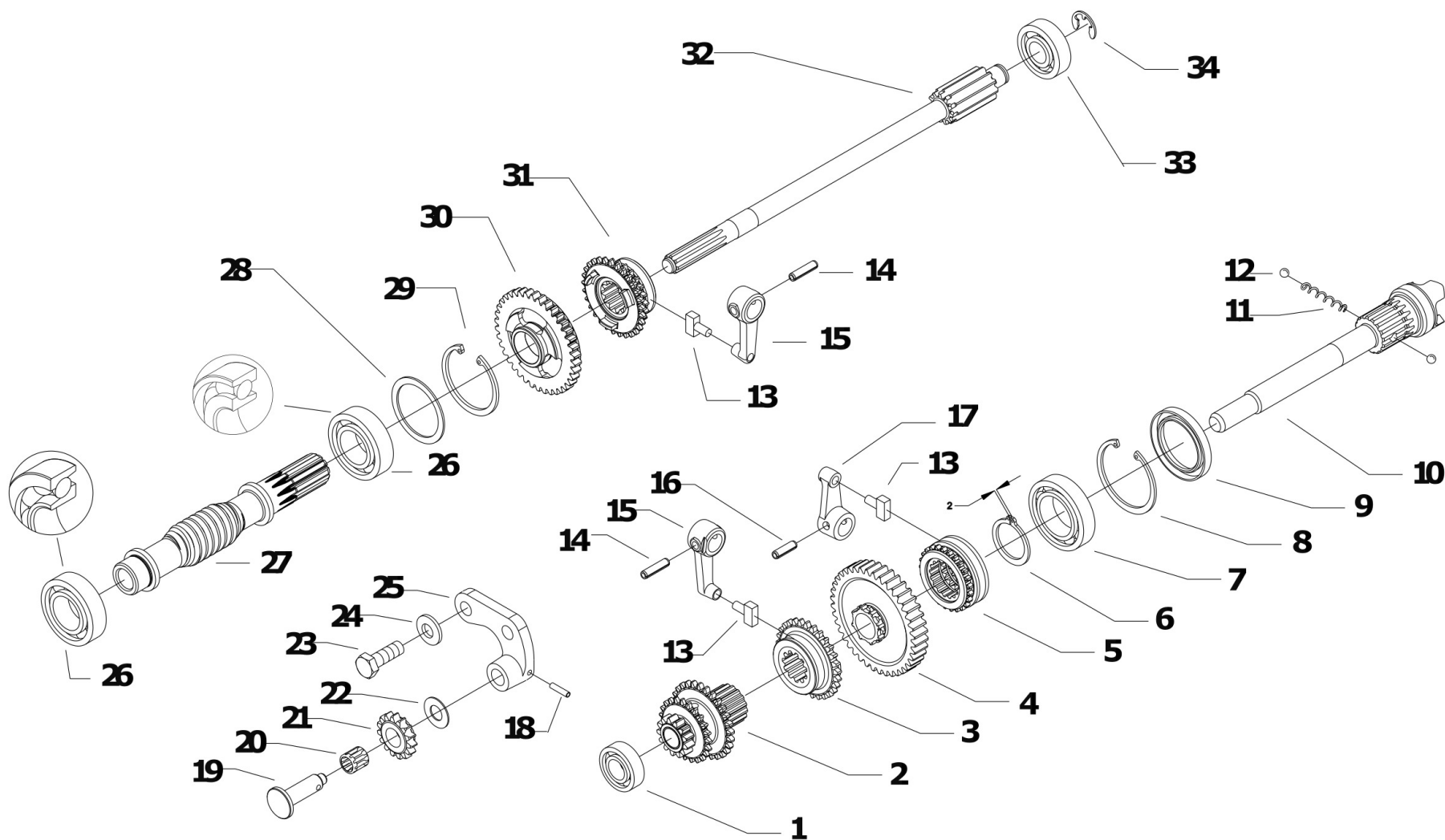

 [Click for info](#)

★ = new part

Pos.	Id	Q.ty	Description	Note
1	37111151		BEARING 6202 (15X35X11)	
2	59056730		TRIPLE GEAR	
3	52456370		SLIDER	
4	59056707		GEAR	
5	52456706		PTO COUPLING	
6	35121031		SEEGER RING E 30 UNI 7436	
7	37112229		BEARING 6006 (30X55X13) SKF	
8	35111055		SEEGER RING I 55 DIN 472	
9	38213800		OIL SEAL 38X55X7	
10	52456335		PTO SHAFT L=161	
11	58056391		SPRING	
12	37910832		BALL 1/4	
13	58043086		SHOE	
14	34213060		ROLL PIN	
15	52456389		LEVER	
16	34213061		ROLL PIN	
17	52456390		LEVER	
18	34211042		ROLL PIN	
19	56456736		GEAR PIN	
20	37320120		ROLLER CAGE 12X15/10	
21	56456347		GEAR	
22	56356348		ADJUSTING RING	
23	31112211		SCREW TE M10X30 UNI 5739	
24	31421101		WASHER 10 DIN 679	
25	52456349		GEAR SUPPORT	
26	37141250		BEARING 7205-B OBL SKF	
27	56456480		VITE S.F.2 PRINCIPI SX	
28	56356328		ADJUSTING RING SP=1,5	
28	56356329		ADJUSTING RING SP=1,6	



Pos.	Id	Q.ty	Description	Note
28	56356330		ADJUSTING RING SP=1,7	
28	56356331		ADJUSTING RING SP=1,8	
29	35111052		SEEGER RING I 52 DIN 472	
30	52456732		GEAR 1a 3C	
31	52456733		SLIDING 3C	
32	52456339		SHAFT	
33	37111152		BEARING 6302 (15X42X13) SKF	
34	35211120		SEEGER RING E 12 UNI 7434	



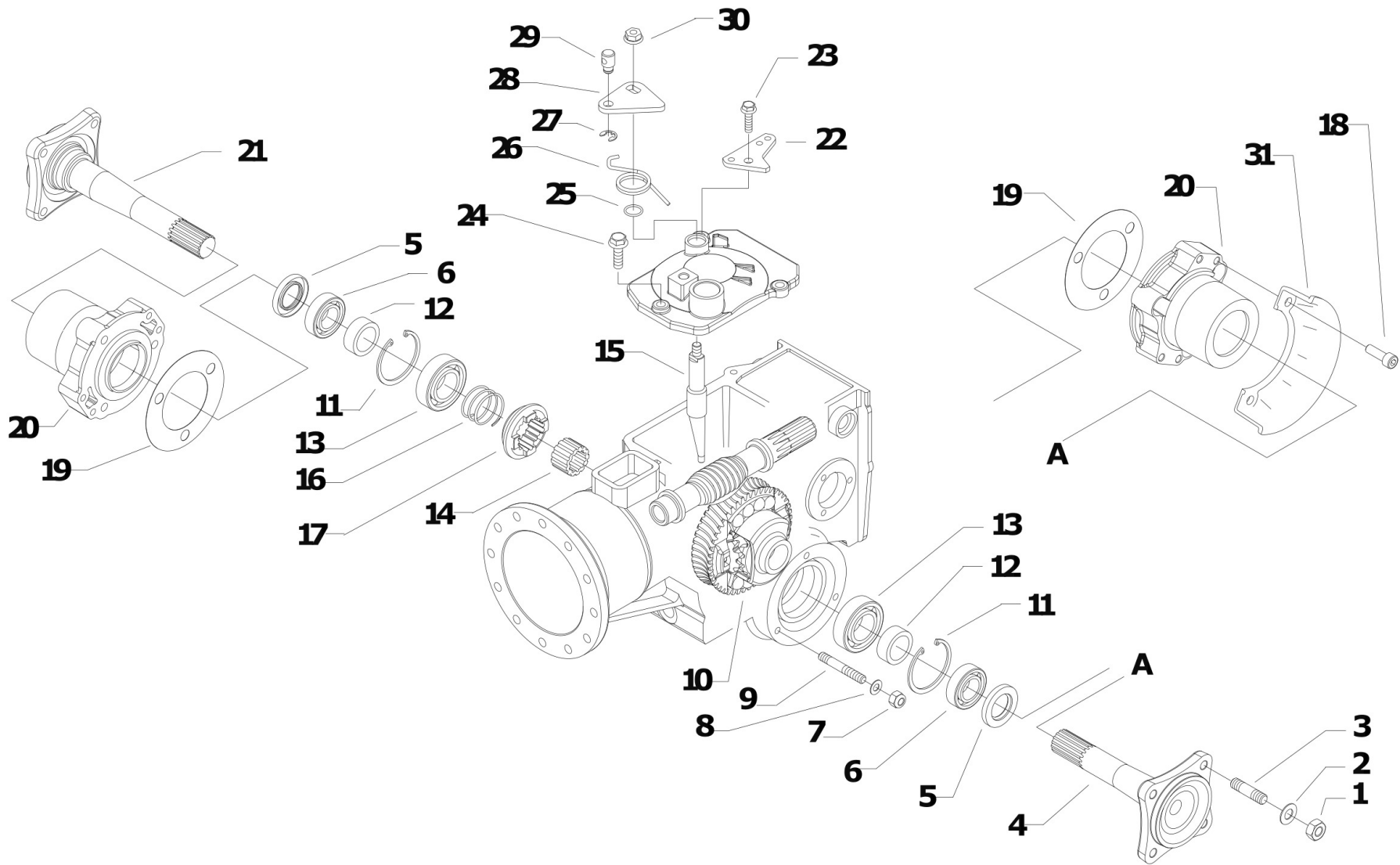

 [Click for info](#)

★ = new part

Pos.	Id	Q.ty	Description	Note
1	31211100		NUT M10	
2	31423105		SPRING WASHER 10,5	
3	31312102		STUD BOLT M10X40X24X12	
4	52448187N		AXLE SHAFT	
5	38213002		OIL SEAL 30X40X7	
6	37111253		BEARING 6005 (25X47X12)	
7	31241080		HEXAGON SELFLOCK NUT M8	
8	31423084		SPRING WASHER 8,4	
9	31312080		STUD BOLT M8X46X20X12	
10	59048181		DIFFERENTIAL GEAR	
11	35111047		SEEGER RING I 47 DIN 472	
12	56148184		RING	
13	37111250		BEARING	
14	56448183		SPACER	
15	56443871		ROD	
16	58043874		SPRING	
17	56448196		COUPLING	
18	31152085		SCREW TCEI M8X25 UNI 5931	
19	58043855		GASKET	
20	53243851N		HUB	
21	52448188N		AXLE SHAFT	
22	56157274Z		56157274Z	
23	31112167		SCREW TE C/F M8X30 DIN 6921 8G	
24	31112166		SCREW TE C/F M8X25 DIN 6921 8G	
25	38111400		O-RING (14,00X1,78)	
26	58043881N		SPRING	
27	35211060		SEEGER RING E 6 UNI 7434	
28	56156219Z		LEVER	
29	56156828Z		STOP	



Pos.	Id	Q.ty	Description	Note
30	31241084		SELFLOCK NUT M8 6S	
31	53156934		PROTEZIONE MOZZI DF	



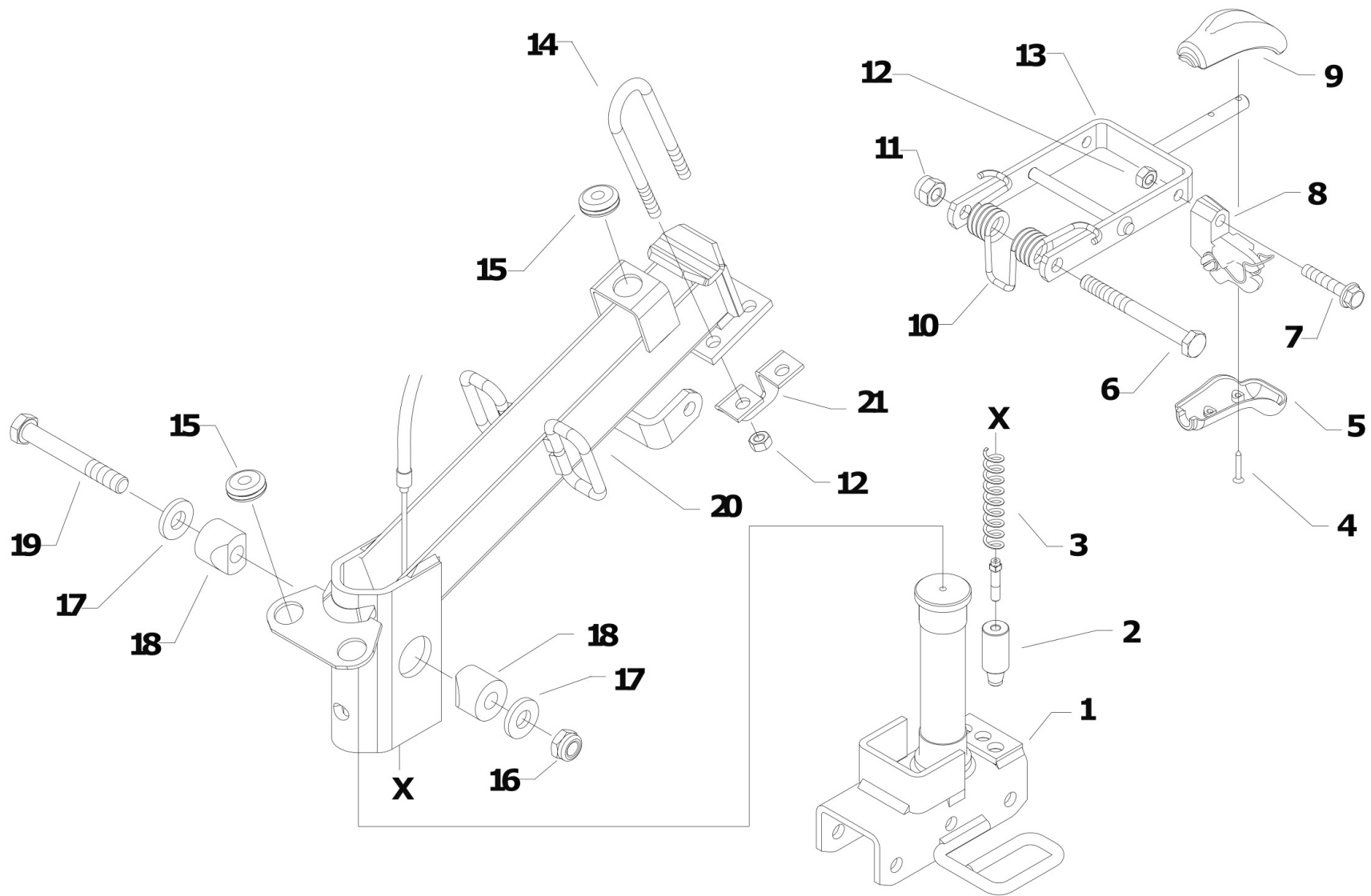

 [Click for info](#)

★ = new part

Pos.	Id	Q.ty	Description	Note
1	59056943N		SUPPORTO GUIDA MF 615	
2	56356924		FERRULE	
3	58056918		SPRING	
4	31100451		SCREW 3,5X25	
5	55157213		GRIP	
6	31111229		SCREW TE M10X110 UNI 5737 8G	
7	31112165		SCREW TE C/F M8X35 DIN 6921 8G	
8	59243337		ROD SUPPORT WITH SPRING	
9	55157212		GRIP	
10	58056942N		SPRING	
11	31241100		SELFLOCK HEXAGON NUT M10	
12	31241080		HEXAGON SELFLOCK NUT M8	
13	59057010N		LEVER	
14	56156940		U BOLT	
15	58056991		CABLE GLAND 90/200/30	
16	31241126		SELFLOCK NUT M12	
17	31421100Z		CUP SPRING 25X12,2X1,5 D2093	
18	52156917		WEDGE	
19	31112293		SCREW TE M12X80 UNI 5737	
20	59056820N		COLUMN	
21	56156974N		SUPPORT	



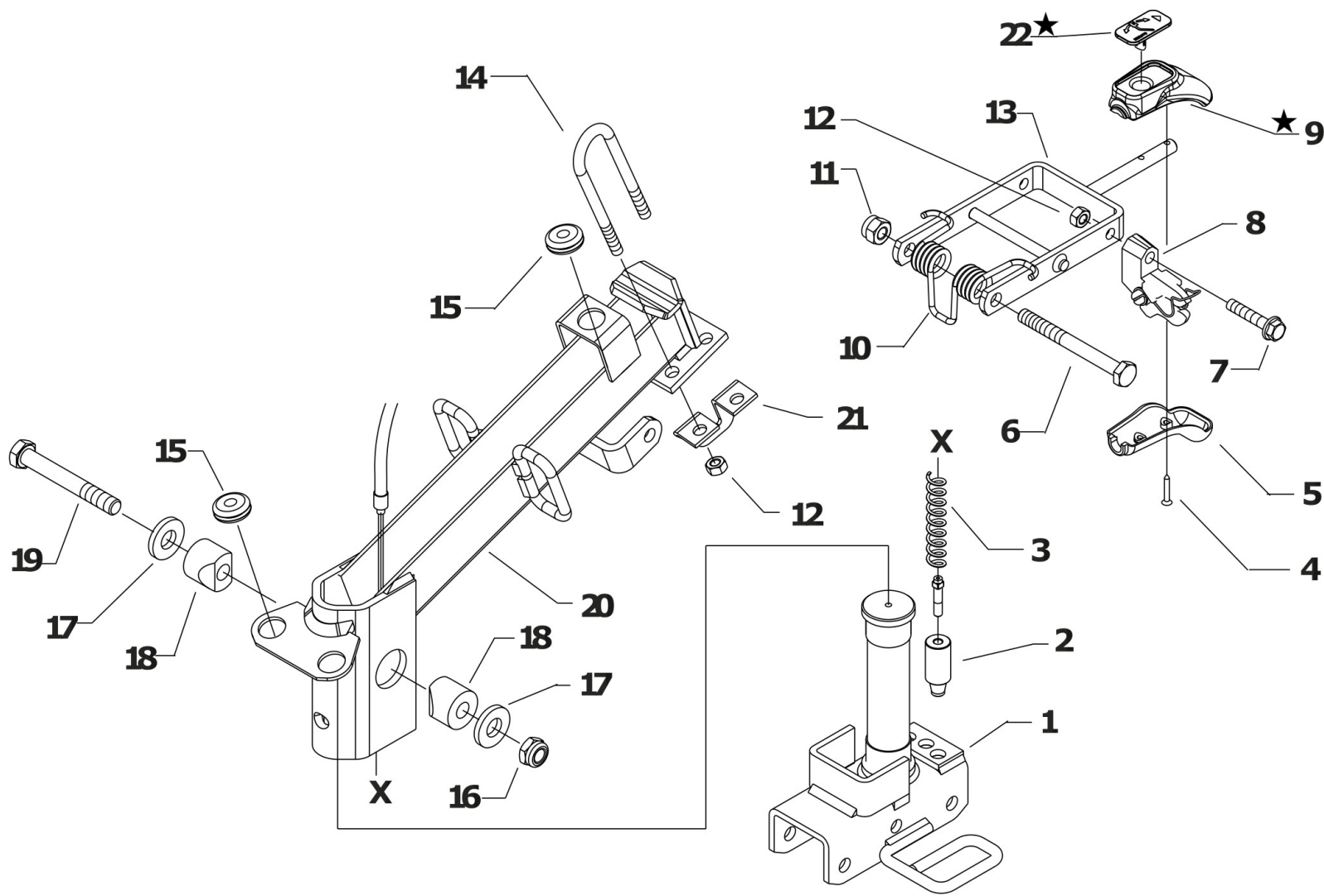

[Click for info](#)

★ = new part



Pos.	Id	Q.ty	Description	Note
1	59056943N		SUPPORTO GUIDA MF 615	
2	56356924		FERRULE	
3	58056918		SPRING	
4	31100451		SCREW 3,5X25	
5	55157213		GRIP	
6	31111229		SCREW TE M10X110 UNI 5737 8G	
7	31112165		SCREW TE C/F M8X35 DIN 6921 8G	
8	59243337		ROD SUPPORT WITH SPRING	
9	552C1776		IMPUGNATURA SUP NERA INSERTO	
10	58056942N		SPRING	
11	31241100		SELFLOCK HEXAGON NUT M10	
12	31241080		HEXAGON SELFLOCK NUT M8	
13	59057010N		LEVER	
14	56156940		U BOLT	
15	58056991		CABLE GLAND 90/200/30	
16	31241126		SELFLOCK NUT M12	
17	31421100Z		CUP SPRING 25X12,2X1,5 D2093	
18	52156917		WEDGE	
19	31112293		SCREW TE M12X80 UNI 5737	
20	59056820N		COLUMN	
21	56156974N		SUPPORT	
22	552C1779		INSERTO REG. STEGOLE	



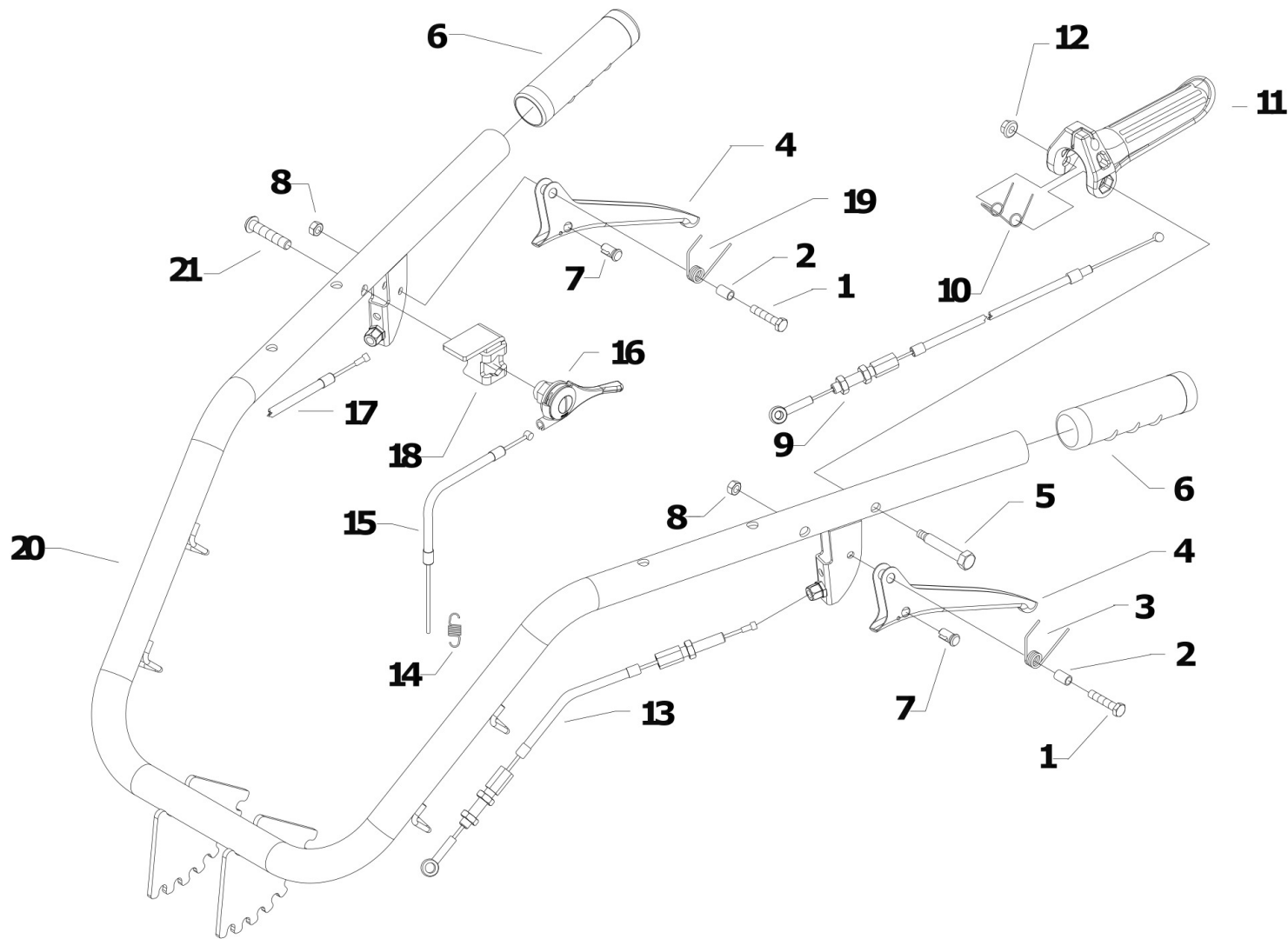

 [Click for info](#)

★ = new part

Pos.	Id	Q.ty	Description	Note
1	31112089		SCREW TE M6X25 UNI 5739 8G	
2	56156603Z		SPACER	
3	58050345		SPRING	
4	56148470N		LEVER	
5	56356184Z		LEVER PIN	
6	58048000		KNOB D=27	
7	58150313		CABLE CLAMP	
8	31241060		HEXAGON SELFLOCK NUT M6	
9	58056191		LINE L=1560	
10	58056186Z		SPRING	
11	55256185		LEVER	
12	31241065		SELFLOCK NUT M6	
13	58056190		LINE L=1460	
14	58056154		RESTORING SPRING	GP160 - GX200
14	58056155		RESTORING SPRING	GX270
15	58056815		LINE AND SHEATH L=1950	
16	58002538		ACCELERATOR	
17	58056193		TRANSMISSION	
18	56156874N		PANEL	
19	58056593		SPRING	
20	59256175		HANDLE BAR	
21	31121020		SCREW TBCEI M8X40 ISO7380 10K Z	



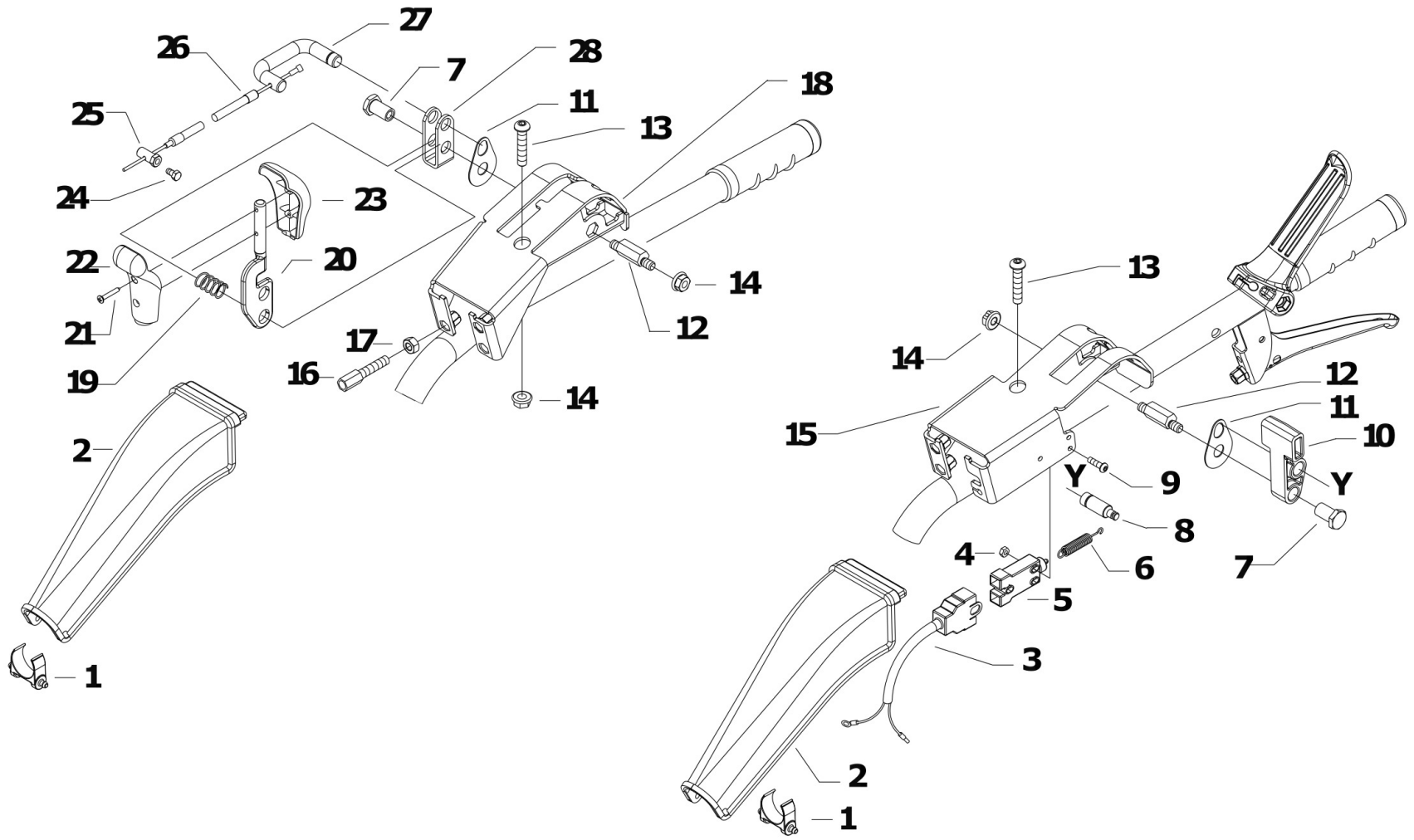

 [Click for info](#)

★ = new part

Pos.	Id	Q.ty	Description	Note
1	55256836		SUPPORT, ELECTRICAL BOX	
2	55256835		PROTECTION COVER	
3	58056837		WIRING	
4	31241042		SELFLOCK NUT M4 FL.6S	
5	58048009		ENGINE STOP SWITCH	
6	58047712		SPRING	
7	56148287		STUD BOLT	
8	56156834Z		INDEXING BOLT	
9	31121024		SCREW TBCEI FL.M4X25	
10	55256197		MOTOR STOP LEVER	
11	56356833Z		SMALL PLATE	
12	56356858Z		PIN	
13	31121020		SCREW TBCEI M8X40 ISO7380 10K Z	
14	31241084		SELFLOCK NUT M8 6S	
15	59256180		SUPPORT	
16	58056595		ADJUSTING SCREW M8	
17	31211080		NUT M8	
18	59256850		SUPPORT	
19	58049830		SPRING	
20	52156810Z		COMMAND LEVER	
21	31100451		SCREW 3,5X25	
22	55157215		GRIP	
23	55157214		GRIP	
24	31112090		SCREW TE M6X16 UNI 5739 8G	
25	56356840Z		CLAMPING SCREW	
26	58056848		LINE AND SHEATH L=930	
27	56156832Z		U BOLT	
28	56156859Z		FORK	



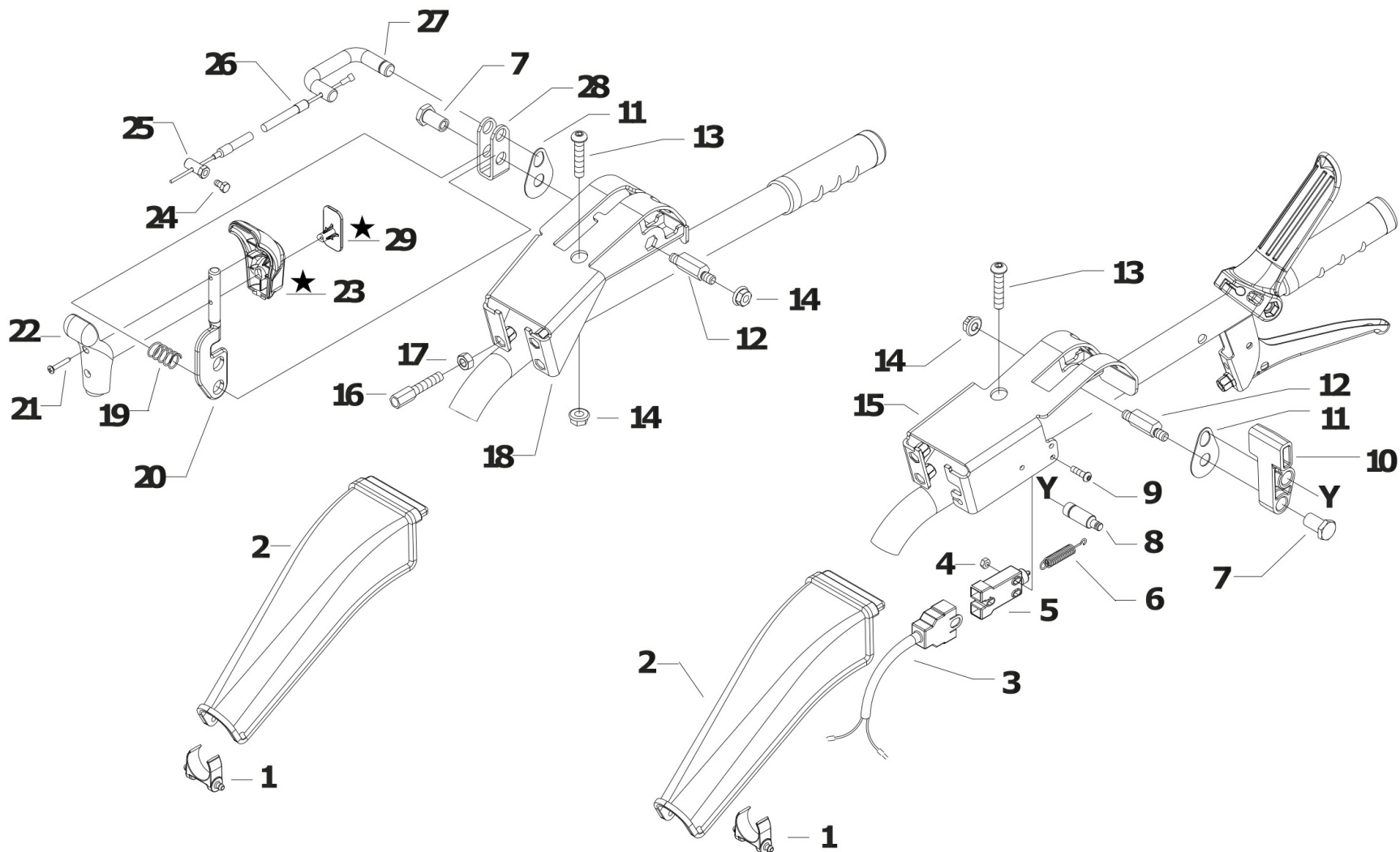

[Click for info](#)

★ = new part

Pos.	Id	Q.ty	Description	Note
1	55256836		SUPPORT, ELECTRICAL BOX	
2	55256835		PROTECTION COVER	
3	58056837		WIRING	
4	31241042		SELFLOCK NUT M4 FL.6S	
5	58048009		ENGINE STOP SWITCH	
6	58047712		SPRING	
7	56148287		STUD BOLT	
8	56156834Z		INDEXING BOLT	
9	31121024		SCREW TBCEI FL.M4X25	
10	55256197		MOTOR STOP LEVER	
11	56356833Z		SMALL PLATE	
12	56356858Z		PIN	
13	31121020		SCREW TBCEI M8X40 ISO7380 10K Z	
14	31241084		SELFLOCK NUT M8 6S	
15	59256180		SUPPORT	
16	58056595		ADJUSTING SCREW M8	
17	31211080		NUT M8	
18	59256850		SUPPORT	
19	58049830		SPRING	
20	52156810Z		COMMAND LEVER	
21	31100451		SCREW 3,5X25	
22	55157215		GRIP	
23	552C1786		IMPUGNATURA SUP ROSSA INSERTO	
24	31112090		SCREW TE M6X16 UNI 5739 8G	
25	56356840Z		CLAMPING SCREW	
26	58056848		LINE AND SHEATH L=930	
27	56156832Z		U BOLT	
28	56156859Z		FORK	
29	552C1784		INSERTO FRECCIE	



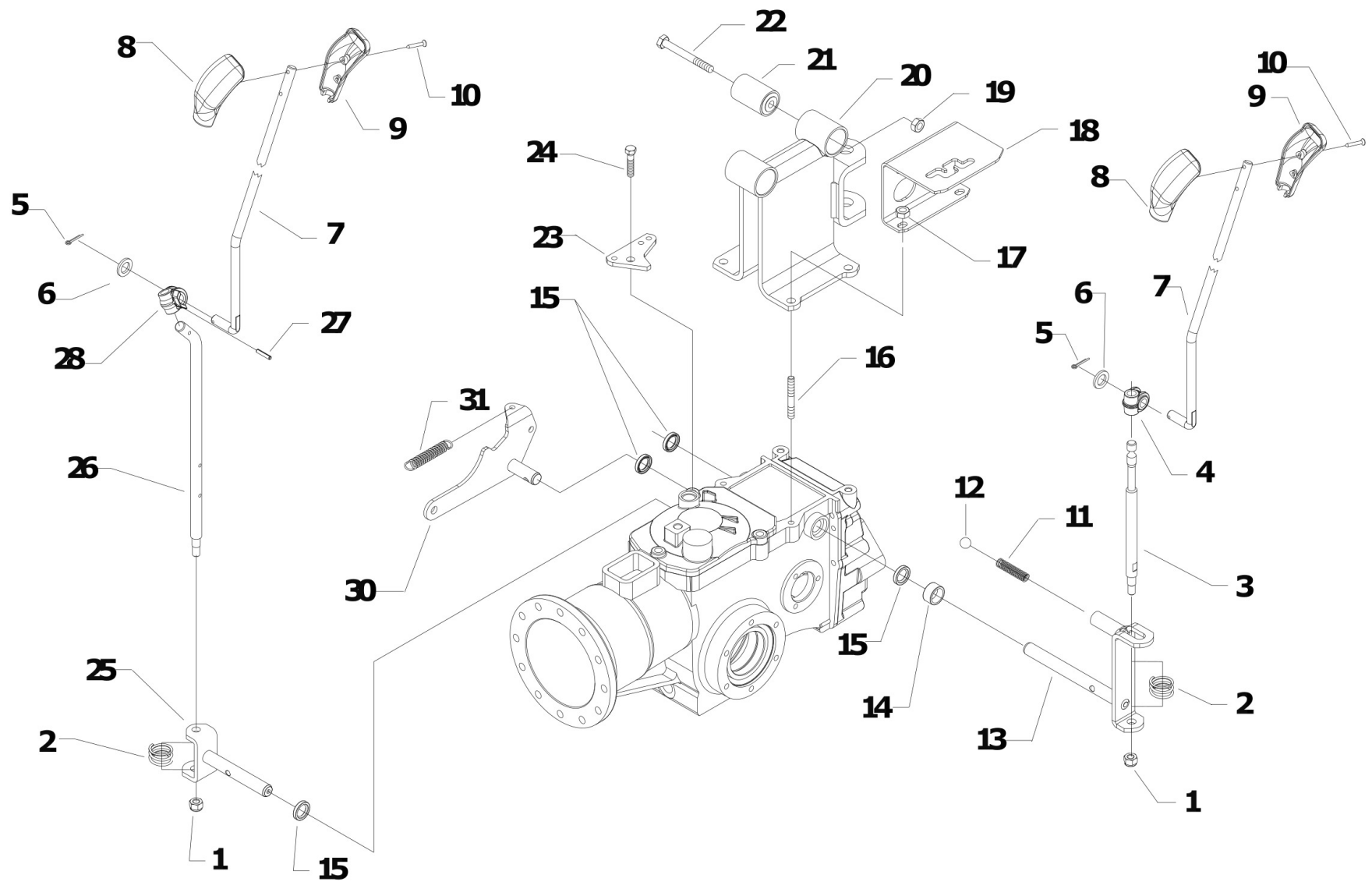

 [Click for info](#)

★ = new part

Pos.	Id	Q.ty	Description	Note
1	31241080		HEXAGON SELFLOCK NUT M8	
2	58057232Z		SPRING	
3	56356738Z		COMMAND LEVER	
4	55242528		JOINT	
5	34110028		SPLIT PIN A3X15 UNI 1336	
6	31411104		WASHER 10,5x18	
7	56156792N		PULL ROD 2+2 ED	
8	55157212		GRIP	
9	55157213		GRIP	
10	31100451		SCREW 3,5X25	
11	58043176		SPRING	
12	37911532		BALL 15/32	
13	59056735Z		GEARBOX COMPLETE LEVER	
14	56157257Z		SPACER	
15	38211400		OIL SEAL 14X22X4	
16	31312082		STUD BOLT M8X38X14X20	
17	31241084		SELFLOCK NUT M8 6S	
18	56156734H		SELECTOR	
19	31241100		SELFLOCK HEXAGON NUT M10	
20	59056920		SUPPORT	
21	30010142		SILENT-BLOCK 10,2X30X45X49	
22	31111217		SCREW TE M10X75 UNI 5737 8G	
23	56157274Z		56157274Z	
24	31112152		SCREW TE M8X30 UNI 5739 8G	
25	590C1040Z		COMPLETE PTO LEVER GALV.	
26	561C1043Z		LONG PDF LEVER	
27	34213024		ROLL PIN	
28	55248379		PTO JOINT	



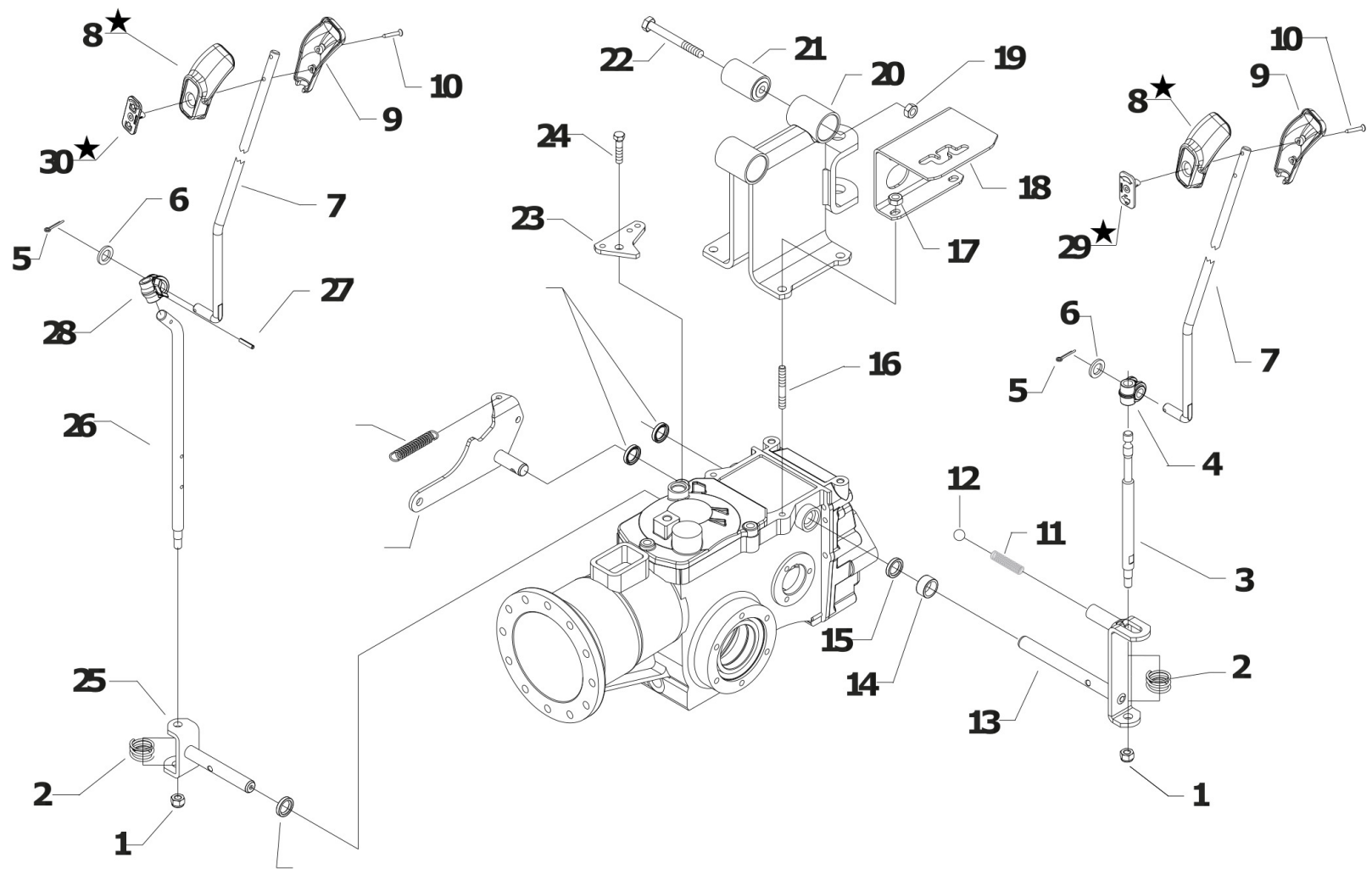

[Click for info](#)

★ = new part



Pos.	Id	Q.ty	Description	Note
1	31241080		HEXAGON SELFLOCK NUT M8	
2	58057232Z		SPRING	
3	56356738Z		COMMAND LEVER	
4	55242528		JOINT	
5	34110028		SPLIT PIN A3X15 UNI 1336	
6	31411104		WASHER 10,5x18	
7	56156792N		PULL ROD 2+2 ED	
8	552C1776		IMPUGNATURA SUP NERA INSERTO	
9	55157213		GRIP	
10	31100451		SCREW 3,5X25	
11	58043176		SPRING	
12	37911532		BALL 15/32	
13	59056735Z		GEARBOX COMPLETE LEVER	
14	56157257Z		SPACER	
15	38211400		OIL SEAL 14X22X4	
16	31312082		STUD BOLT M8X38X14X20	
17	31241084		SELFLOCK NUT M8 6S	
18	56156734H		SELECTOR	
19	31241100		SELFLOCK HEXAGON NUT M10	
20	59056920		SUPPORT	
21	30010142		SILENT-BLOCK 10,2X30X45X49	
22	31111217		SCREW TE M10X75 UNI 5737 8G	
23	56157274Z		56157274Z	
24	31112152		SCREW TE M8X30 UNI 5739 8G	
25	590C1040Z		COMPLETE PTO LEVER GALV.	
26	561C1043Z		LONG PDF LEVER	
27	34213024		ROLL PIN	
28	55248379		PTO JOINT	
29	552C1782		INSERTO MARCIA MF	



Pos.	Id	Q.ty	Description	Note
30	552C1780		INSERTO PTO MF	





1



2



3



4

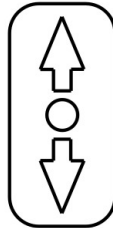

5

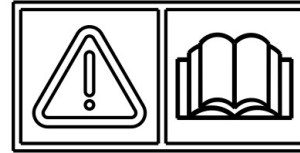

6



7



8



9



10

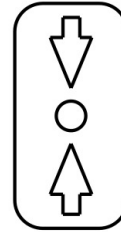

11



12



13

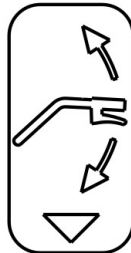

14

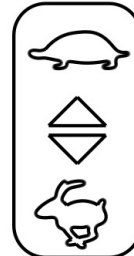

15

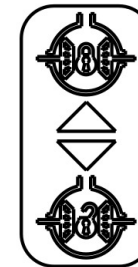

16

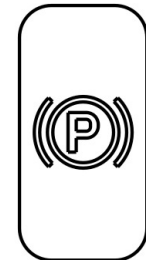

17

 [Click for info](#)

★ = new part

Pos.	Id	Q.ty	Description	Note
1	58056866		DECAL	
2	58057677		DECAL	
3	58057665		ADESIVA 3 MARCE 630 PS	
4	58056869		DECAL	
5	58057748		DECAL	
6	58057724		DECAL	
7	58057767		DECAL	
8	58056868		DECAL	
9	58057774		DECAL	
10	58093089		DECAL	
11	580C1772		ADESIVA INVERTITORE MF 614 PS	
12	58057768		DECAL	
13	530C0056		DECAL MADE IN ITALY	
14	58057746		DECAL	
15	58057773		DECAL	
16	58057625		DECAL	
17	58057747		DECAL	



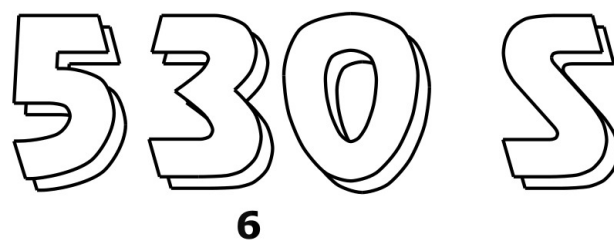
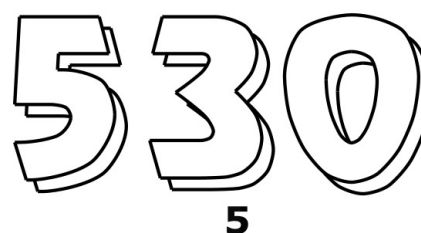
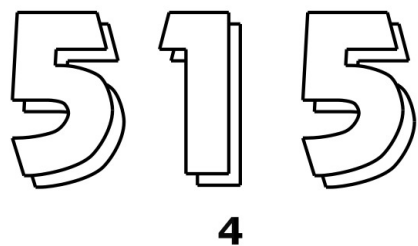
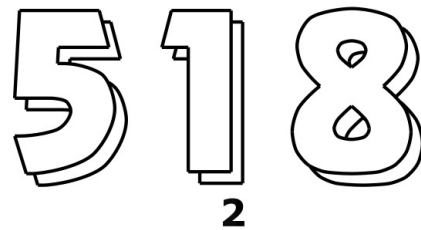
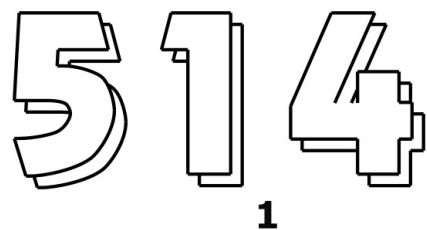

 [Click for info](#)

★ = new part

Pos.	Id	Q.ty	Description	Note
1	58052199		ADESIVA 514 PS	
2	58052196		ADESIVA 518 PS	
3	53052176		BIG FERRARI BRAND	
4	58052195		ADESIVA 515 PS	
5	58052197		ADESIVA 530	
6	58052190		DECAL 530S /11	
7	53052175		MEDIUM FERRARI BRAND	



		A	B	C
*	5.0-10"	39115010	39415010	58048330
	21 x 11.0 - 8"	39113501	TUBELESS	58057795
**	20 x 8.00 - 10"	39116018	39416018	58044804
	23 x 8.5 - 12"	39118522	39416018	592C0453
	16 x 6.5 - 8"	391111664	TUBELESS	58057839

KIT GEMELLAGGIO PER 5.0-10"
 TWINNING KIT FOR 5.0-10"
 JUMELAGE KIT POUR 5.0-10"
 KT GEMELOS POR 5.0-10"
 ZWILLINGS KIT 5.0-10"

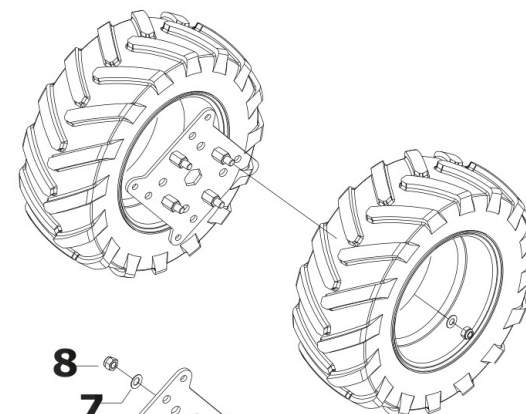

* SUPERBITE

(50-10') 9

14

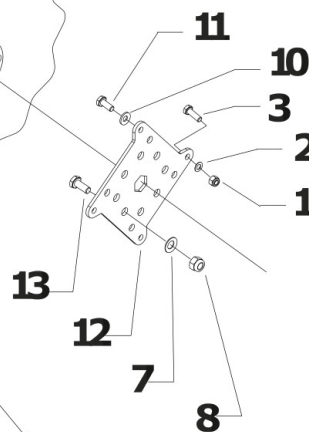
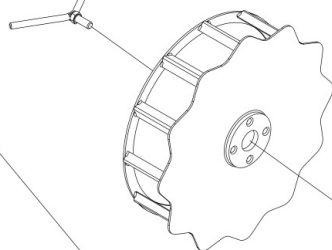

** SUPERBITE

20x800-10'

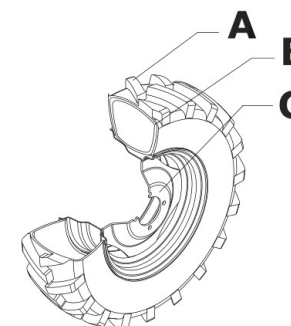
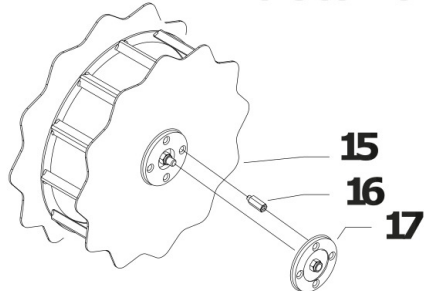

 [Click for info](#)

★ = new part

Pos.	Id	Q.ty	Description	Note
1	31241080		HEXAGON SELFLOCK NUT M8	
2	31423084		SPRING WASHER 8,4	
3	31112151		SCREW TE M8X25 UNI 5739 8G	
4	31241100		SELFLOCK HEXAGON NUT M10	
5	31423105		SPRING WASHER 10,5	
6	56359554		PIN	
7	31423130		SPRING WASHER EL 13 DIN 137-B	
8	31241120		SELFLOCK NUT M12	
9	59259555		SUPER-BITE WHEEL X 5.00-10	
10	31421101		WASHER 10 DIN 679	
11	31112219		SCREW TE M10X25 UNI 5739	
12	59059551		FLANGE	
13	56359553		PIN	
14	59059561		SCREW	
15	59259598		WHEEL	
16	56359593		DRIVING PIN	
17	59059591		SPACER	

