

September 2015

ECOsine® Active

Harmonics compensation in real-time – The compact,
fast and flexible solution for better Power Quality

www.myeocosine.com

SCHAFFNER
energy efficiency and reliability





Schaffner Group

The Schaffner Group is the international leader in development and production of solutions which ensure efficient and reliable operation of electronic systems. The Group's broad range of product and services includes EMC/EMI components, harmonic filters and magnetic components as well as development and implementation of customized solutions. Schaffner components are deployed in energy-efficient drive systems and electronic motor controls, in wind and photovoltaic systems, rail technology, machine tools and robotics as well as power supplies for numerous electronic devices in sectors such as medical technology or telecommunications. Schaffner provides on-site service to customers around the world through an efficient, global organization and makes ongoing investments in research, development, production and sales to systematically expand its position as leader on the international market.

A global one-stop shop

EMC/EMI filters

- PCB filters
- IEC inlet filters / Power entry modules
- DC filters
- Single-phase filters
- Three-phase filters
- Three-phase + neutral line filters
- Open frame filters

EMC/EMI chokes

Feedthrough filters and capacitors

Automotive components

Customized solutions

Power Quality products

- Line reactors
- dv/dt reactors and filters
- Sine wave filters
- Harmonic filters
- Regen reactors and filters
- Transformers

Customized solutions

Consumers of electricity often suffer from poor power quality in their supply lines

Reliability and efficiency are assessed as being important to business operation. This includes reliable operation of machines, manufacturing systems, and office equipment. Nevertheless, this is frequently not the case and often there is no obvious reason, despite the use of UPSs and back-up generators.

- Distribution lines and networks cannot be fully utilized
- High percentage of energy losses in the power lines
- Increased wear and limited system availability
- Downtime for equipment and systems

Power quality problems in the internal power network are often the reason. Measurements and network analysis can detect the root cause of the problem.

ECOsine® Active eliminates harmonics and reduces the cost for reactive power

Whether for machinery, welding equipment, variable-frequency drives, or electric motors: Almost all non-linear consumers nowadays can cause substantial voltage distortion.

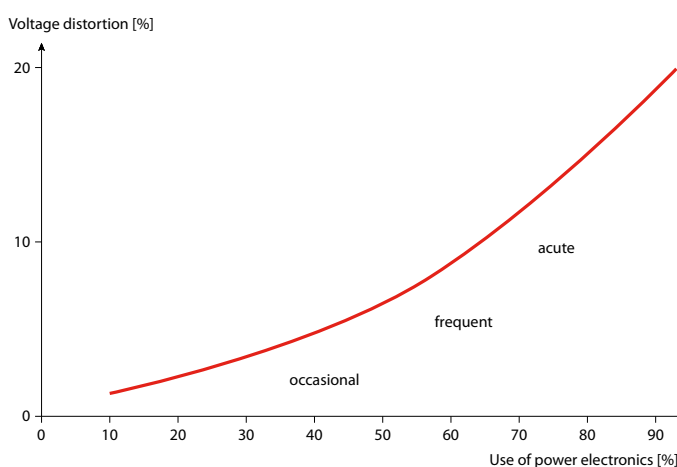

A clear tendency worldwide: Voltage distortion increases along with the increasing use of power electronics

Harmonic currents up to the 50th harmonic and expensive reactive power: ECOsine® Active eliminates both direct and reliable. This improves power quality and reduces cost.

Savings in reactive power can be easily calculated. However, cost reduction due to less wear on equipment, less troubleshooting, or even prevented production downtime are more difficult to quantify. Studies show that this amounts to billions in damages each year. ECOsine® Active is thus a good investment for all areas with system perturbation problems.

ECOsine® Active – digital technology offers great benefits

As the latest generation of active harmonic filters ECOsine® Active offers numerous additional advantages compared to traditional technology. Faster, smaller, and more performance. This makes power quality easier.

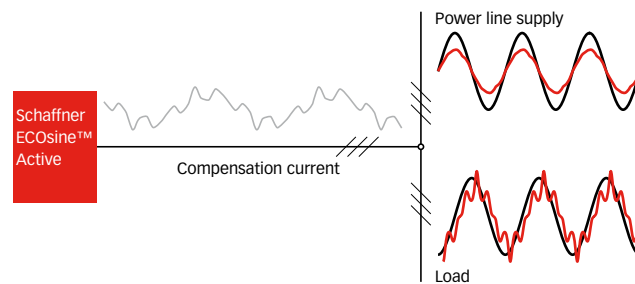

- | **Ultra-fast:** ECOsine® Active responds to disturbances in less than 300µs and eliminates them before they can cause damage.
- | **Super-compact:** The smallest 30A filter is handy, small, and easy to install, and also the 300A cabinet unit provides the highest performance in the most compact package.
- | **Optimized for maintenance:** Thanks to its design, the central modules in the 200 to 300A industrial models can be removed in less than 15 minutes (MTTR).
- | **Suitable for industrial use:** With the IP54 protection class ECOsine® Active is resistant to dust and other environmental influences.
- | **Numerous options:** The ECOsine® Active range covers specifications from 30 to 300A and 200 to 480V in either 3 or 4-wire technology.
- | **Adaptive:** ECOsine® Active compensates for individual disturbance patterns in a targeted manner and automatically adapts to changing network topologies.

Harmonics caused by non-linear loads are reliably compensated with ECOsine® Active and the THD is reduced.

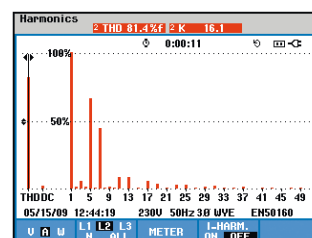

Without ECOsine® Active:
Harmonics and reactive power stress the electrical installation and lead to problems

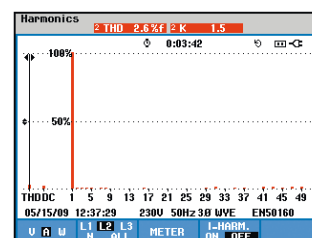

With ECOsine® Active:
Reactive power and harmonics are actively compensated, thus ensuring better power quality





ECOSine® Active 30/50A (3-wire) – The compact and easy-to-install filter

The smallest ECOSine® Active version is ideal for the reliable compensation up to the 50th harmonic, as well as reactive power, in a targeted manner. Thanks to its compact dimensions and low weight, this filter can be easily installed in any environment. For protection class requirements up to IP54 both wall and cabinet installation are possible. Not only space-saving, it is also economical in terms of power loss with only 1300W. With a response time of less than 300µs in ultra-fast mode, it is also possible to optimally compensate dynamic loads.

This compact filter offers convincing technical features and an excellent mechanical design. A higher power level can be easily attained by paralleling up to 5 units.

ECOSine® Active 30/60A (4-wire) – The solution for building technology

This ECOSine® Active version mitigates harmonics also on the neutral wire and is particularly qualified for the reliable compensation of 3rd and triple harmonics up to the 50th order. Low audible noise emissions make it the perfect solution for building technology, banking, data centers and hospitals.

ECOSine® Active 100/120A – The standard for 3 and 4-wire technology is always the perfect fit

Only slightly larger and heavier than the 30/50/60A devices, the 100/120A unit can deal with twice the current. It is the perfect solution for those who need more performance right from the beginning and want to centrally connect it to their consumers.

ECOSine® Active 200/250/300A – The industrial model is a real power pack

With up to 300A of compensation current, this filter remains fully capable for the highest requirements and for large production facilities, like those found in the heavy industry. The cabinet version comes with forced air cooling, as well as internal liquid cooling for the power electronics with an integrated water/air heat exchanger. This is hi-tech in a compact package.



Minimal time-to-repair thanks to a modular design (MTTR <15 minutes)

The ready-for-connection industrial cabinet unit with its modular design and IP54 protection class is especially advantageous and convenient. The individual modules can be easily accessed and removed from the front of the cabinet. An MTTR value of less than 15 minutes with an MTBF value of up to 100,000 hours ensures shortest service times and long maintenance intervals.

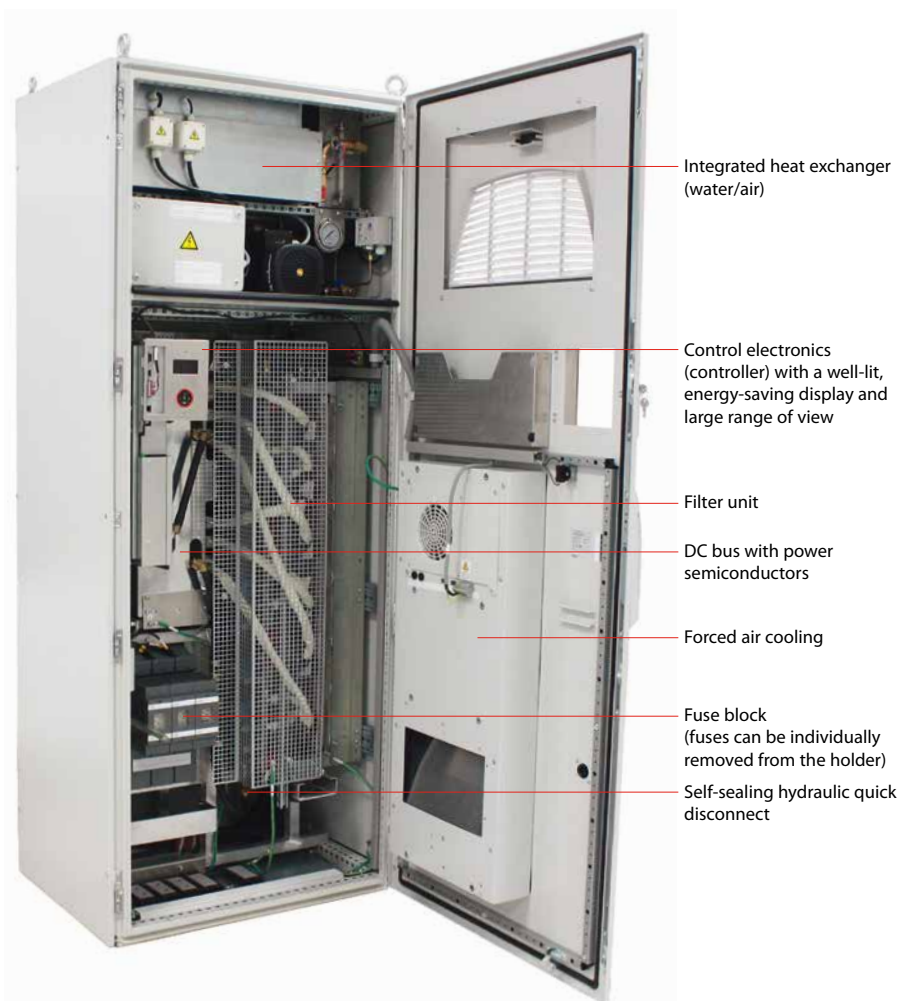

Integrated heat exchanger (water/air)

Control electronics (controller) with a well-lit, energy-saving display and large range of view

Filter unit

DC bus with power semiconductors

Forced air cooling

Fuse block (fuses can be individually removed from the holder)

Self-sealing hydraulic quick disconnect



Control electronics are easy to remove.



Modules (filter unit and power element) can be released from the front with just a few bolt/plug connections.

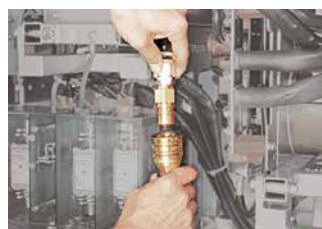

Liquid cooling can be disconnected quickly and without any spilling using quick-release couplings.



Modules can be popped out towards the front.

ECOsine® Active offers an intelligent solution for many applications

There is a wide range of companies and institutions that can clearly improve the power line quality of manufacturing systems or office facilities using ECOsine® Active. On the one hand, this filter can be factored-in during the planning and implementation phase of new systems. On the other hand, ECOsine® Active is also an intelligent solution for existing installations and facilities with power quality problems.



- | | | |
|----------------------------|---|------------------------------|
| ■ Automotive industry | ■ Oil and gas exploration | ■ Variable-frequency drives |
| ■ Building automation | ■ Paper mills | ■ Water/wastewater treatment |
| ■ Cement industry | ■ Ship propulsion | ■ Welding equipment |
| ■ Data and banking centers | ■ Steel industry | ■ Wind turbines |
| ■ Elevators | ■ Tunnel ventilation | |
| ■ HVAC installations | ■ Uninterruptible power supplies (UPSs) | |
| ■ Machines and automation | | |

ECOsine® Active – the best harmonic filter money can buy

Most countries already have strict standards and limits for harmonic injection. Companies and facilities that consume energy are forced to monitor their internal power lines and ensure compliance with these limits. In critical cases, the energy provider may cut the power. Using ECOsine® Active, detected deviations can be reduced and brought back into the tolerance range again. This provides much confidence.

The following standards specify limits for harmonics in networks/units:

EN 61000-2-2, EN 61000-2-4, EN 61000-3-2, EN 61000-3-12, EN 61000-3-3 as well as EN 50160, TOR D2, IEEE 519-1992, G5/4 and D.A.CH.CZ.

ECOsine® Active is the easiest way to comply with these standards and limits.



Technical specifications

Mains frequency:	50/60Hz ± 3 Hz
Filter performance:	Up to 50th order
Parallel operation:	Up to 5 units
Response time:	300 µs
Overload capability: (peak value)	2.5x rated compensation current 2x rated compensation current for FN 34xx-120-xxx-x
Cooling Type:	Forced air cooling FN 34xx – 30/50/60/100/120-xxx-x Forced air cooling + internal liquid cooling for FN 34xx – 200/250/300-xxx-x
Ambient temperature:	0–40°C with derating up to 55°C 0–30°C with derating up to 55°C for FN 3430-xxx-200-x and FN 34xx-60/120-xxx-x For derating parameters please refer to the second table below (Derating parameters)
Ambient conditions: (EN 50178)	Pollution degree: 2; Relative humidity: <95%, non-condensing, 3K3; Temperature: Storage –25°C to +55°C, 1K3, 1K4 – Transportation –25°C to +70°C, 2K3
Interfaces:	Modbus RTU (RS485), Modbus TCP/IP (Ethernet)
Altitude:	1,000 m with derating up to 4,000 m, 1%/100 m
Switching frequency:	16 KHz
Controller topology:	Digital with FFT analysis
Current limitation:	Nominal current
Current transformer:	50:5 to 50,000:5
Protection class:	FN 34xx – 30/50/60/100/120-xxx-x Standard IP 20 (optional IP 54) FN 34xx-200/250/300-xxx-x IP 54

Filter	Rated comp. Current [A]		Mains voltage @ 50 Hz [VAC]	Mains voltage @ 60 Hz [VAC]	Power loss [W]	Noise level [dBA, 1m]	Weight [Kg]	Cooling air requirements [m3/h]	Approval
	Ph.	N							
FN 3420-50-200-3	50		200/240 ±10%	200/240 ±10%	<1150	65	47	<550	CE
FN 3420-100-200-3	100		200/240 ±10%	200/240 ±10%	<2000	68	105	<1400	CE
FN 3430-30-200-4	30	90	200/240 ±10%	200/240 ±10%	<900	63	70	<400	CE
FN 3430-60-200-4	60	180	200/240 ±10%	200/240 ±10%	<1600	63	70	<600	CE
FN 3420-30-480-3	30		380 ±15%–480 ±10%	380 ±15%–480 ±10%	<900	65	47	<350	CE, A, C
FN 3420-50-480-3	50		380 ±15%–480 ±10%	380 ±15%–480 ±10%	<1300	65	47	<550	CE, A, C
FN 3420-100-480-3	100		380 ±15%–480 ±10%	380 ±15%–480 ±10%	<2200	68	105	<1400	CE, A, C
FN 3420-120-480-3	120		380 ±15%–480 ±10%	380 ±15%–480 ±10%	<2500	68	105	<1400	CE
FN 3420-200-480-3	200		380 ±15%–415 ±10%	480 ±10%	<5000	70	440	<2600	CE
FN 3420-200-480-3-UL	200		380 ±15%–415 ±10%	480 ±10%	<5000	70	440	<2600	CE, U, A, C
FN 3420-250-480-3	250		380 ±15%–415 ±10%	480 ±10%	<6000	70	440	<3100	CE
FN 3420-250-480-3-UL	250		380 ±15%–415 ±10%	480 ±10%	<6000	70	440	<3100	CE, U, A, C
FN 3420-300-480-3	300		380 ±15%–415 ±10%	480 ±10%	<7500	70	440	<3400	CE
FN 3420-300-480-3-UL	300		380 ±15%–415 ±10%	480 ±10%	<7500	70	440	<3400	CE, U, A, C
FN 3430-30-400-4	30	90	380 ±15%–415 ±10%	380 ±15%–415 ±10%	<950	63	70	<400	CE
FN 3430-60-400-4	60	180	380 ±15%–415 ±10%	380 ±15%–415 ±10%	<1800	63	70	<600	CE
FN 3430-100-400-4	100	300	380 ±15%–415 ±10%	380 ±15%–415 ±10%	<3000	69	145	<1700	CE
FN 3430-120-400-4	120	300	380 ±15%–415 ±10%	380 ±15%–415 ±10%	<3000	69	145	<1700	CE
FN 3430-200-400-4	200	600	380 ±15%–415 ±10%	–	<5500	70	525	<2800	CE
FN 3430-250-400-4	250	750	380 ±15%–415 ±10%	–	<6300	70	525	<3300	CE
FN 3430-300-400-4	300	750	380 ±15%–415 ±10%	–	<8500	70	525	<3600	CE

ECOsine® Active uses intelligent digital technology

Its flexibility is obvious, as it can be connected to the power line on the load or grid side with numerous current transformer-ratios. Once configured with just a few clicks, the present line current will be permanently measured and all harmonics and phase displacements are actively compensated. To do this, ECOsine® Active calculates the appropriate compensation currents within microseconds, which are then generated and fed into the network. This is possible due to full digital control and fast high performance computing.

Derating parameters

	30–40°C	40–55°C
FN3420-xxx-200-3	no derating	3%/K
FN3430-xxx-200-4	3%/K	3%/K
FN3430- 60-400-4	2%/K	2%/K
FN34xx-120-xxx-x	1,2%/K	2%/K
FN34xx others types	no derating	2%/K

More details can be found in the ECOsine® Active user manual (available at www.schaffner.com).



Mechanical data

ECOsine® Active 30/50A

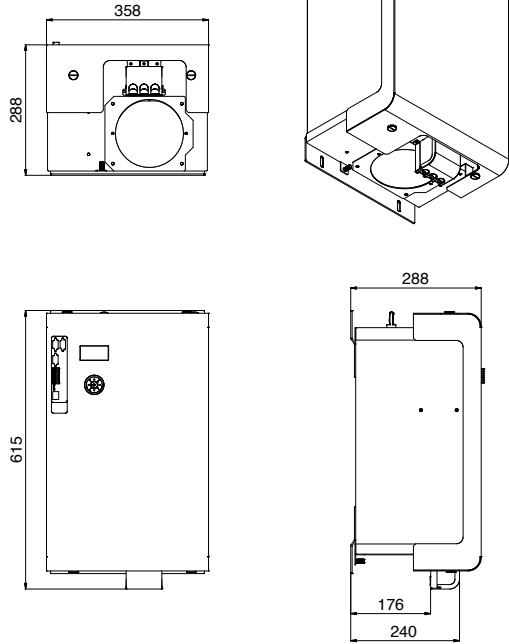

ECOsine® Active 30/60A

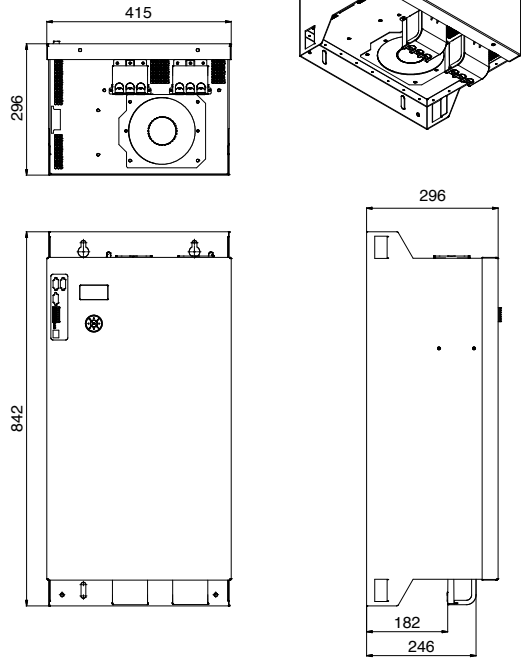

Mechanical data

ECOsine® Active 100/120A (3-wire)

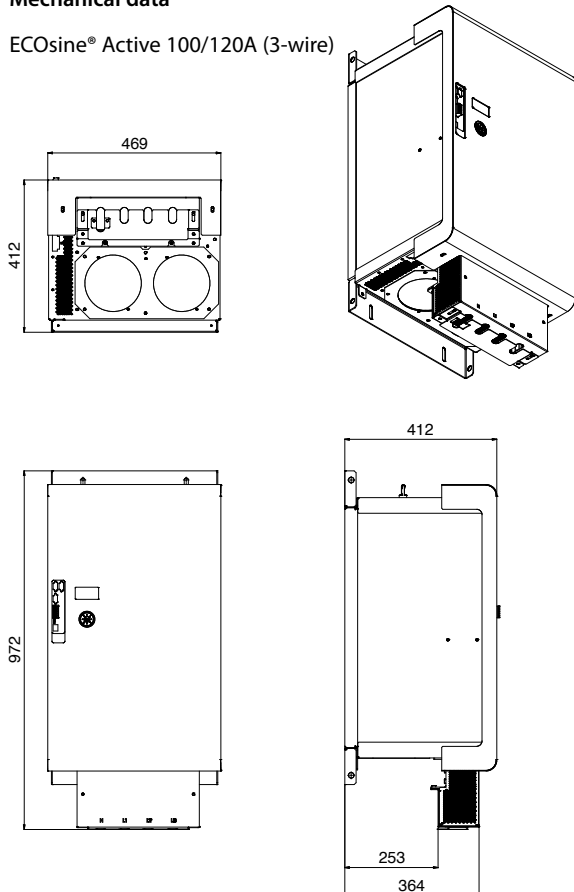

Mechanical data

ECOsine® Active 100/120A (4-wire)

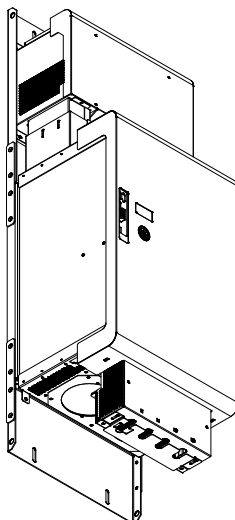
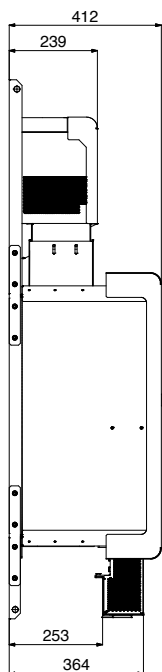
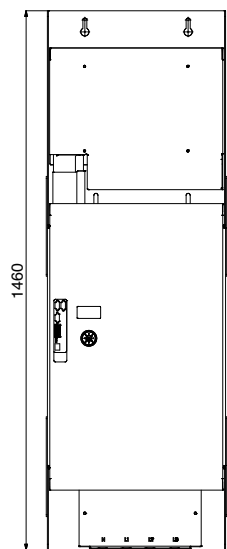
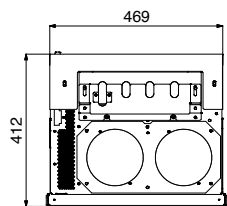

Mechanical data

ECOsine® Active 200/250/300A

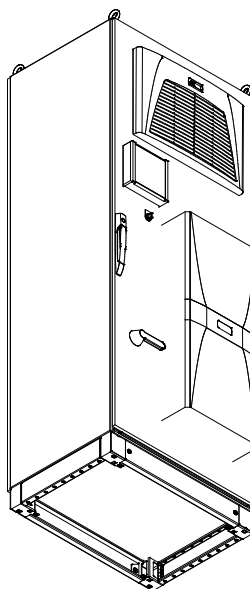
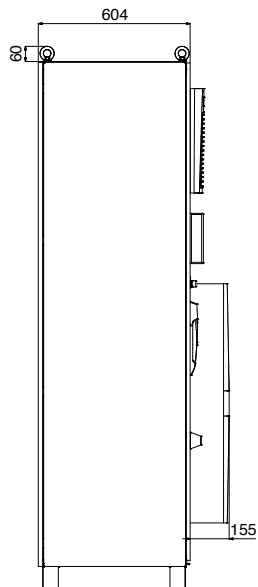
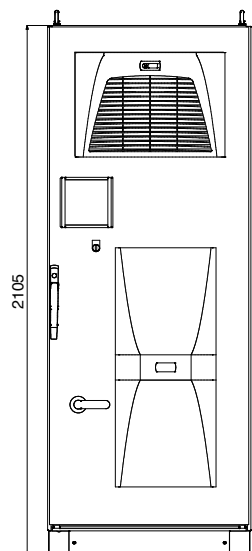
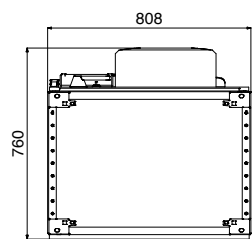

AHF Viewer supports monitoring on a PC

Commissioning, as well as the selection and setting of individual parameters, are very user-friendly in all ECOsine® Active versions thanks to a multi-language, menu-based control panel and display. These steps can also be conveniently performed via a PC-connection using the AHF Viewer software-package. The current network status can optionally be retrieved online and adjustments can be made in remote operation either via RS485 or Ethernet TCP/IP.

Your partner for individual power quality. The Schaffner worldwide customer support network is available to assist you in finding the most suitable solution for optimum power quality in your installation and facilities: Throughout all phases from consultation to network analysis and planning, right up to implementation and after sales support.

ECOsine® Active provides

- **Reliability:** Eliminates all relevant disturbance patterns in the power lines
- **Cost-savings:** Avoids/reduces wear on electrical loads and over-heating of cables and transformers
- **Efficiency:** Prevents losses due to production downtimes
- **Flexibility:** Constantly adapts to the network topology
- **Fast response time:** Compensates disturbances before they can cause damage
- **Economy:** Lowers energy costs through reduced reactive power demand
- **Compact dimensions:** Requires very little space compared to traditional solutions
- **Ruggedness:** Provides protection according to IP54
- **Plug-and-play:** Simple installation and intuitive operation

Schaffner – more than just filters. Schaffner ECOsine® standard filters are available for different supply networks throughout the world. They are UL listed, CE marked, and fulfill the requirements of the low voltage directive. A broad selection of power, current, voltage and frequency ratings leaves the choice of filter up to the user. However, there are always occasions where different electric or mechanical requirements exist, or where more than just products are needed for the job at hand.

Schaffner is in the unique position of being able to support the user with problem analysis, engineering advice, testing and measurement support, custom products, and a worldwide customer service organisation. Our goal is to ensure that you obtain the level of harmonics mitigation you actually need – guaranteed.

Please contact your local Schaffner partner for comprehensive support. More information can also be obtained from the Schaffner ECOsine® user manual.

ECOsine® Passive

Schaffner is also technology leader for passive harmonic filters. The load-applied ECOsine® advanced passive harmonic filters represent the ideal solution for three-phase power electronics with 6-pulse rectifier front ends, such as AC and DC motor drives. ECOsine® passive harmonic filters are available for 50 and 60 Hertz grids with different voltage levels up to 690 V. They are able to reduce harmonic distortion caused by diode or thyristor (SCR) rectifiers to <5%. More information can be found at www.myecosine.com.



**Headquarters, global innovation
and development center**

Schaffner Group
Nordstrasse 11
4542 Luterbach
Switzerland
T +41 32 681 66 26
F +41 32 681 66 30
info@schaffner.com
www.schaffner.com

To find your local partner within
Schaffner's global network, please go to
www.schaffner.com

Order Nr. SAP 611445
Merkur Druck AG
© 2015 Schaffner Group

The content of this document has
been carefully checked and under-
stood. However, neither Schaffner
nor its subsidiaries assume any liability
whatsoever for any errors or
inaccuracies of this document and
the consequences thereof. Published
specifications are subject to change
without notice. Product suitability
for any area of application must
ultimately be determined by the
customer. In all cases, products must
never be operated outside their
published specifications. Schaffner
does not guarantee the availability of
all published products. This disclaimer
shall be governed by substantive
Swiss law and resulting disputes shall
be settled by the courts at the place
of business of Schaffner Holding AG.
Latest publications and a complete
disclaimer can be downloaded from
the Schaffner website. All trademarks
recognized.

Sales and application centers

China
Schaffner EMC Ltd. Shanghai
T20-3, No 565 Chuangye Road
Pudong New Area
Shanghai 201201
T +86 21 3813 9500
F +86 21 3813 9501 / 02
cschina@schaffner.com
www.schaffner.com

Finland
Schaffner Oy
Sauvonrinne 19 H
08500 Lohja
T +358 19 35 72 71
finlandsales@schaffner.com

France
Schaffner EMC S.A.S.
112, Quai de Bezons
95103 Argenteuil
T +33 1 34 34 30 60
F +33 1 39 47 02 28
francesales@schaffner.com

Germany
Schaffner Deutschland GmbH
Schoemperlenstrasse 12B
76185 Karlsruhe
T +49 721 56910
F +49 721 569110
germanysales@schaffner.com

Italy
Schaffner EMC S.r.l.
Via Galileo Galilei, 47
20092 Cinisello Balsamo (MI)
T +39 02 66 04 30 45/47
F +39 02 61 23 943
italysales@schaffner.com

Japan
Schaffner EMC K.K.
Mitsui-Seimei Sangenjaya Bldg. 7F
1-32-12, Kamiyama, Setagaya-ku
Tokyo 154-0011
T +81 3 5712 3650
F +81 3 5712 3651
japansales@schaffner.com
www.schaffner.jp

Singapore
Schaffner EMC Pte Ltd.
Blk 3015A Ubi Road 1
05-09 Kampong Ubi Industrial Estate
T +65 6377 3283
F +65 6377 3281
singaporesales@schaffner.com

Spain
Schaffner EMC España
Calle Caléndula 93
Miniparc III, Edificio E
El Soto de la Moraleja
Alcobendas
28109 Madrid
T +34 618 176 133
spainsales@schaffner.com

Sweden
Schaffner EMC AB
Turebergstorg 1, 6
19147 Sollentuna
T +46 8 5792 1121 / 22
F +46 8 92 96 90
swedensales@schaffner.com

Switzerland
Schaffner EMV AG
Nordstrasse 11
4542 Luterbach
T +41 32 681 66 26
F +41 32 681 66 41
sales@schaffner.ch

Taiwan
Schaffner EMV Ltd.
6th Floor, No 413
Rui Guang Road
Neihu District
Taipei City 114
T +886 2 87525050
F +886 2 87518086
taiwansales@schaffner.com

Thailand
Schaffner EMC Co. Ltd.
Northern Region Industrial Estate
67 Moo 4 Tambon Ban Klang
Amphur Muang P.O. Box 14
Lamphun 51000
T +66 53 58 11 04
F +66 53 58 10 19
thailandsales@schaffner.com

UK
Schaffner Ltd.
5 Ashville Way
Molly Millars Lane
Wokingham
Berkshire RG41 2PL
T +44 118 9770070
F +44 118 9792969
uksales@schaffner.com
www.schaffner.uk.com

USA
Schaffner EMC Inc.
52 Mayfield Avenue
08837 Edison, New Jersey
T +1 800 367 5566
T +732 225 9533
F +732 225 4789
usasales@schaffner.com
www.schaffner.com/us

Schaffner MTC LLC
6722 Thirlane Road
24019 Roanoke, Virginia
T +276 228 7943
F +276 228 7953
www.schaffner-mtc.com

Schaffner Trencó LLC
2550 Brookpark Road
44134 Cleveland, Ohio
T +216 741 5282
F +216 741 4860
www.schaffner-trencó.com