

CRESSALL EV2 & EVT ADVANCED WATER data sheet COOLED MODULAR RESISTORS



Compact, water cooled resistors for low and medium voltage applications, especially severe conditions in automotive, traction or marine systems.

Manufactured from advanced materials the EV2 and EVT use a patented design that encapsulates and totally separates the resistor elements from the coolant providing a modular, light weight, low volume, high power solution for water cooled applications. Typically our new resistors are 10% of the volume and 15% of the weight of the equivalent conventional convection cooled DBR.

Units can be combined together to handle from 10kW to 600kW and supplied as individual components, frame mounted assemblies for integration in customer's systems or completely enclosed multi-banked systems that include inlet/outlet manifolds, flow and temperature monitoring.

The latest hybrid/electric vehicle developments mean there is an urgent need for a new approach to regenerative braking. Our EVT resistor with its lower 10kW power rating and reduced pressure drop provides the higher reliability, mechanical simplicity and low weight demanded. The EVT is the most cost effective way to ensure any excess energy the vehicle produces is safely and efficiently recycled within the car itself.

The need for three independent braking systems in hybrid/electric vehicles means that regenerative braking using the EVT is the greenest way for these vehicles to dissipate energy.

Features:

Continuous operating voltage to 1.5kV per module.

Available in 1, 2, 3 or 4 module assemblies to meet most power and connection requirements.

Low time constant – achieves operating temperature < 5 seconds.

Applications:

- Electric & Hybrid vehicles
- Winches and cranes
- Cable laying vessels
- Propulsion drives on ships and oil rigs
- Dummy loads
- Discharge resistors

CRESSALL EV2 & EVT construction and operational parameters

The new ceramic material used in the EV2 and EVT has properties that are found individually in many materials but rarely together in the same one.

These key properties are:

High thermal conductivity comparable to aluminium, better than most common metals, enabling very high heat transfer at low temperature differences.

High electrical resistivity ($>10^{14} \Omega \cdot \text{cm}$): comparable to most ceramics, enabling construction of high voltage (up to 7.2kV) heaters.

Construction, components and materials

The illustration shows the patented construction of the 25kW rated EV2 which include:

1. Resistor cover in glass-filled plastic
2. Spring-filled water channels to improve heat transfer
3. O-ring seal
4. Ceramic plate.
5. Fully encapsulated resistor elements and spacers
6. Copper terminals
7. Water inlet and outlet manifolds
8. Resistor body in glass-filled plastic

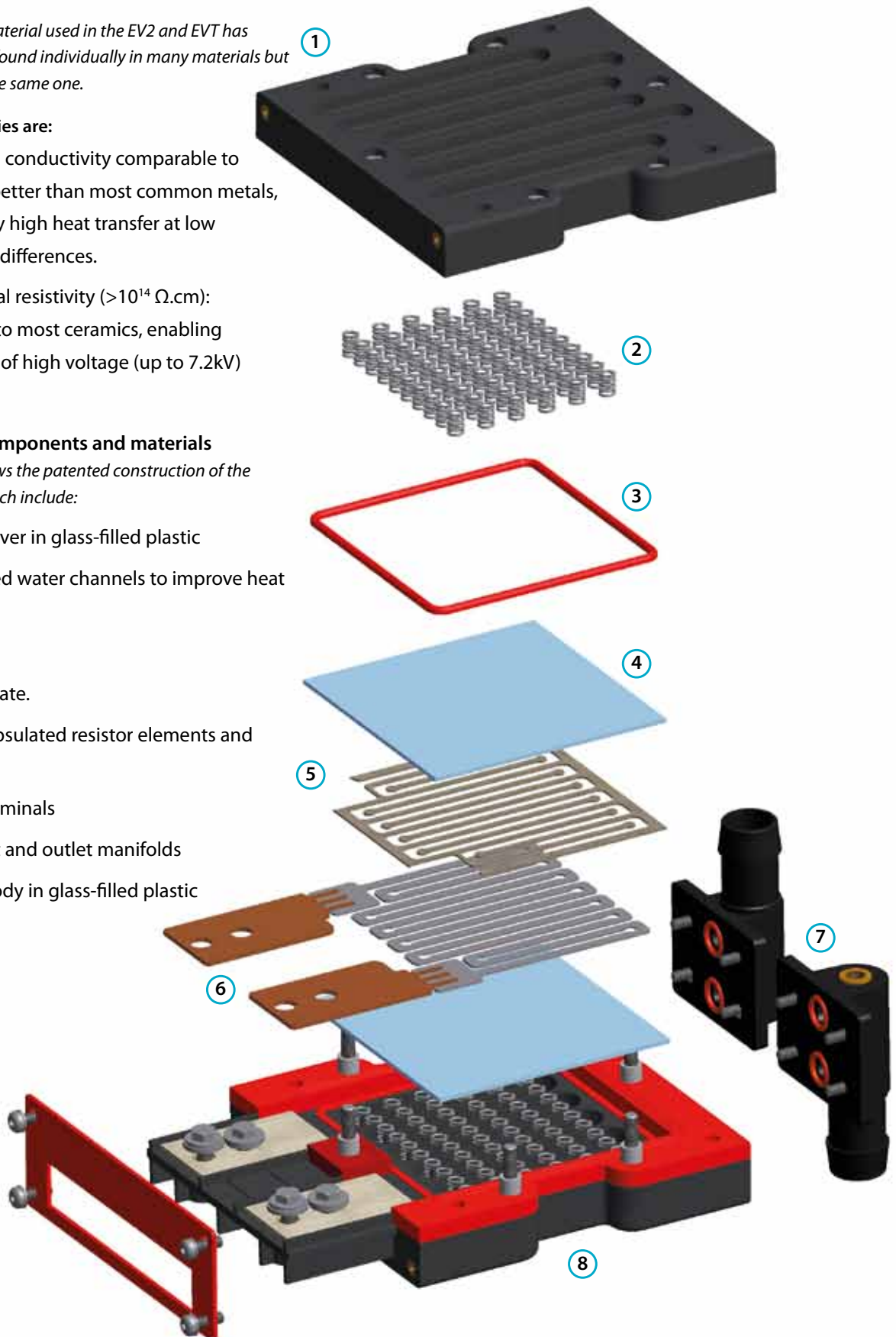



Multiple EV2 units assembled to provide a single 400kW water cooled load



Parameter	EV2	EVT
Nominal Power Rating (Water coolant at 18l/m)	25kW	10kW
Other Power Ratings / Flow Rate	See Tables	
Overload Ratings Available	Up to 28%	N/A
Resistance (Cold)	1.0Ω to 20Ω	
Storage Temperature	-40°C to +80°C	
Operational Temperature	-30°C to +50°C	
Ingress protection	IP56 to BS EN 60529 (with single EV2 terminal cover fitted)	
Electrical interface	M8 bolted connection	
Insulation Voltage Class	1.5kV	
Test Voltage	4.5kV for 60 seconds	
Insulation Resistance Test	>100MΩ at 1kV	
Terminal to Terminal clearance	35mm	
Terminal to Terminal creepage	35mm	
Shock and vibration	JLR spec TPJLR.00.047: 50 hours random vibrations, 3axis shock, 4000 x 30	N/A
Coolant Types	De-ionised Water, 20% Glycol, 50% Glycol	
Maximum Operating Pressure	3 bar	
Test Pressure	6 bar	
Water Interface	2 x pipe stubs for 25mm hose	
Minimum Coolant Flow Rates	See Tables	
Pre-Filtration Level Required	≤100µm	
Materials:	Body & Terminal Cover: Glass-filled Plastic Terminals: Plated copper • Seals: Silicone Rubber	
Edge Gasket Colour	Red	Black
Registered Patents	UK 2478547; China ZL 2012 0455472.7, UK France Germany Italy Netherlands Spain Sweden 2 592 633, Japan 6351926, USA 8.643.464	
Patents Pending	Brazil 10 2012 029181-9, India 1297/KOL/2012, South Korea 10-2012-0128957	

SHOCK AND VIBRATION TESTING with simultaneous power cycling was carried out in our own laboratories to current automotive and traction standards (five hours in each axis).

CRESSALL EV2 & EVT performance data

Pressure Drop Against Flow Rate for EV2

Note! Graphical data is based on a single EV assembly. When supplied as combined modules (2EV, 3EV or 4EV) cooling flows will be in parallel.

For EV modules connected in parallel the pressure drop is the same, the flow rate is the sum of the flows in each module.

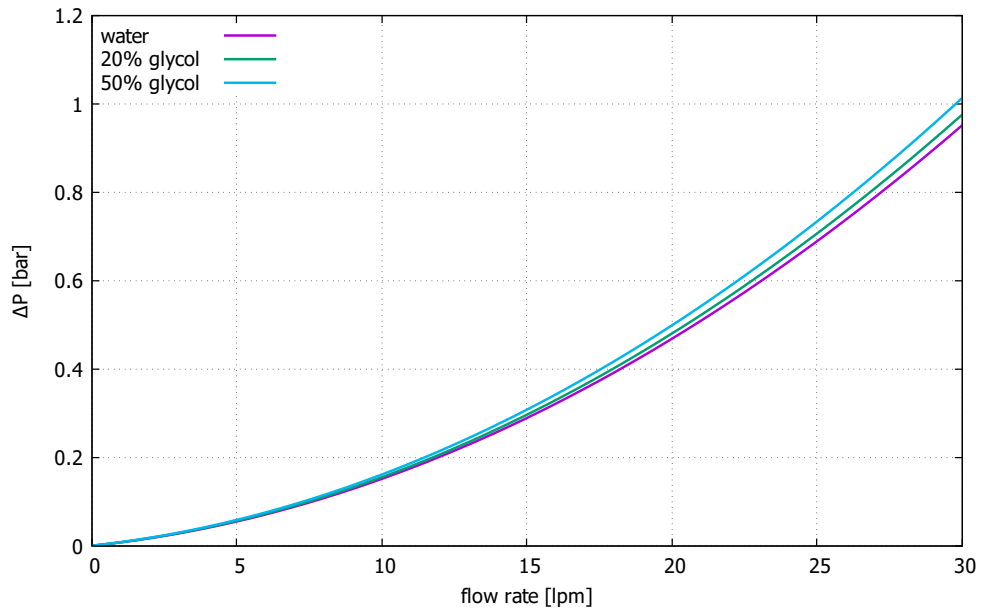

Coolant Temperature Rise Increase Against Power for EV2

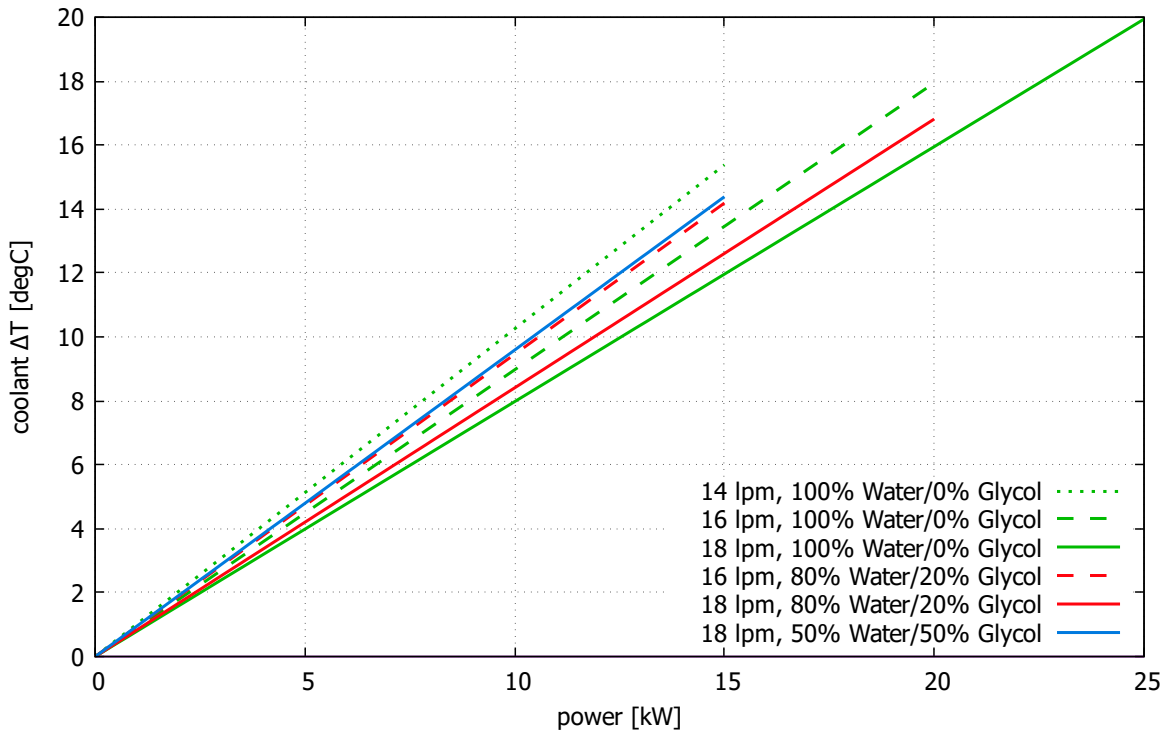

EV2 Power Ratings			
Max. Power (kW) for coolant types:	Min. Flow Rate (l/m)		
	14	16	18
Water	15kW	20kW	25kW
20% Glycol	X	15kW	20kW
50% Glycol	X	X	15kW

EVT Power Ratings			
Max. Power (kW) for coolant types:	Min. Flow Rate (l/m)		
	14	16	18
Water	6kW	8kW	10kW
20% Glycol	X	6kW	8kW
50% Glycol	X	X	6kW

EV2 Overload Ratings			
Max. Power (kW) for coolant types	On Time (s)		
	Cont.	10	1
100% Water/0% Glycol	25kW	28kW	38kW
80% Water/20% Glycol	20kW	23kW	32kW
50% Glycol/ 50% Glycol	15kW	21kW	28kW

Recovery time after overload should be \geq to the on time used.

Overload ratings are offered on EV2 only and are not available on the EVT.



Velocity
Streaming 1
5.28
3.96
2.64
1.32
0.00
[m s⁻¹]

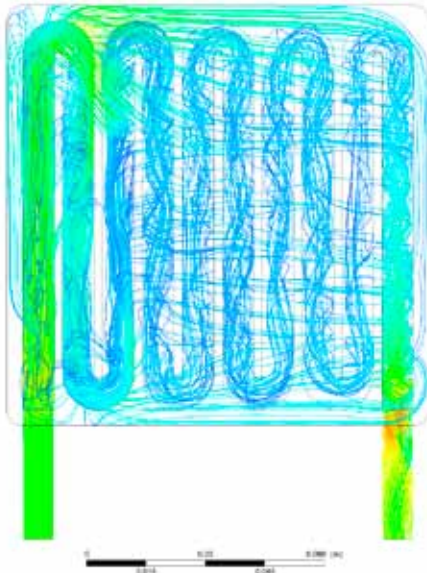

ANSYS
RFX1

A: Thermal-Electric
Total Current Density
Type: Total Current Density
Unit: A/m²
Time: 1
31/01/2018 15:05

3.6413e7 Max
3.2367e7
2.8321e7
2.4275e7
2.0229e7
1.6184e7
1.2138e7
8.092e6
4.0462e6
402.18 Min

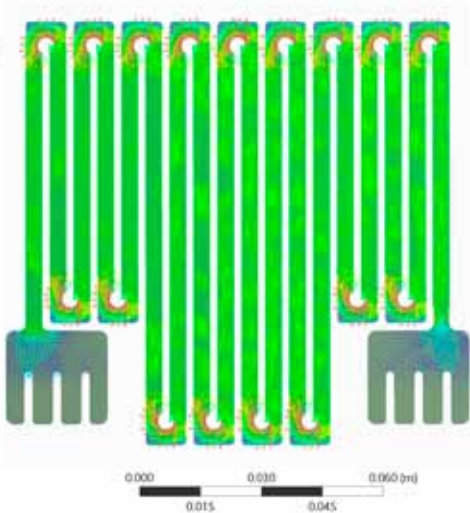

COMPUTER MODELLING has included extensive modelling and full-scale testing of the fluid flows, heat transfer and stresses within the component materials. The design has been through numerous iterations before reaching its present standard.

CRESSALL EV2 & EVT specifications, weights & dimensions

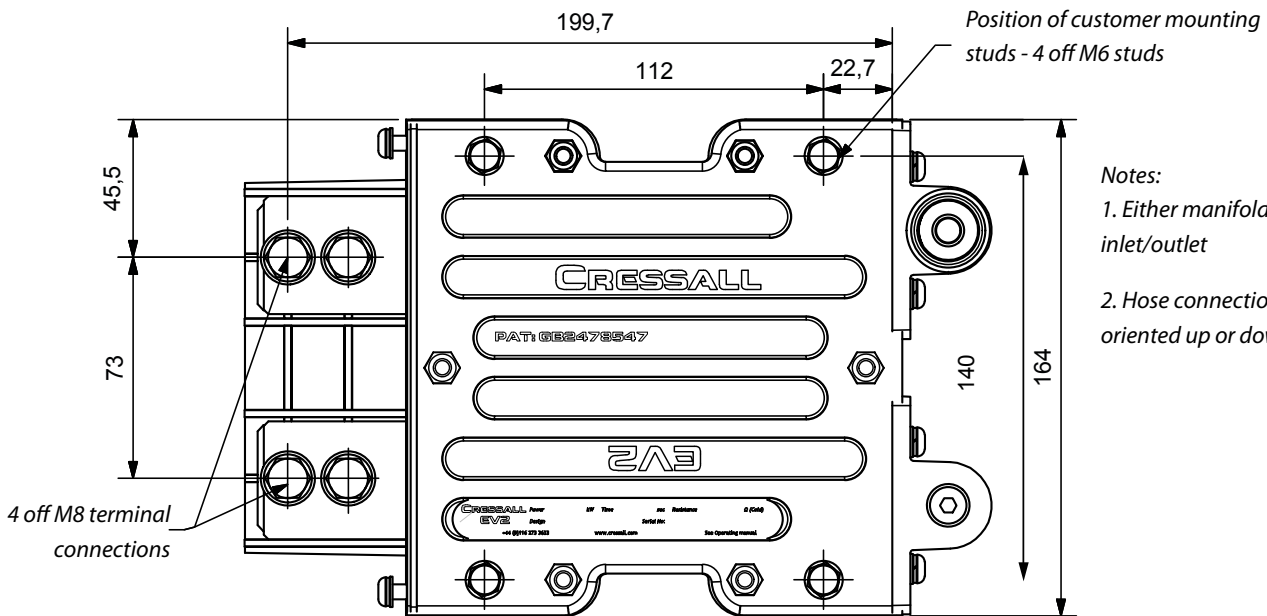
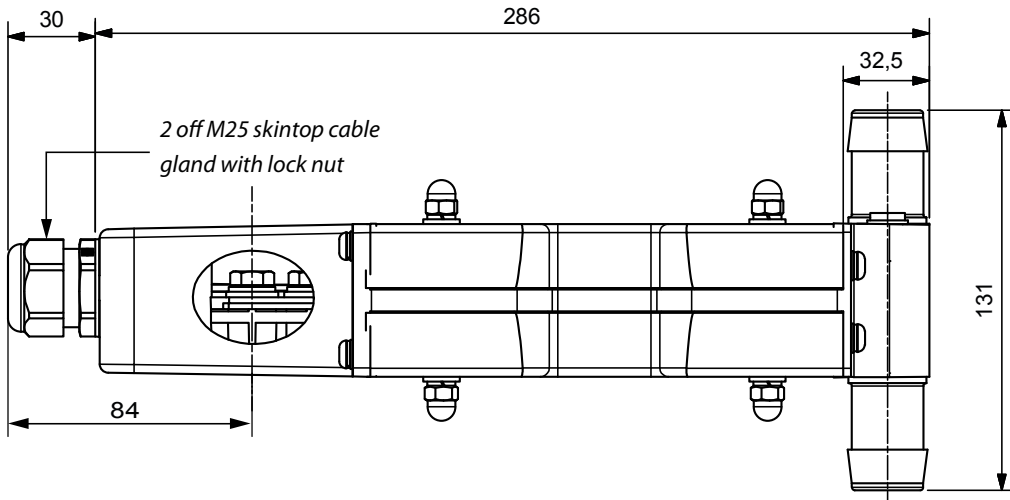

- Notes:
1. Either manifold can be used as inlet/outlet
 2. Hose connection can be oriented up or down

1" (25mm) hose connection

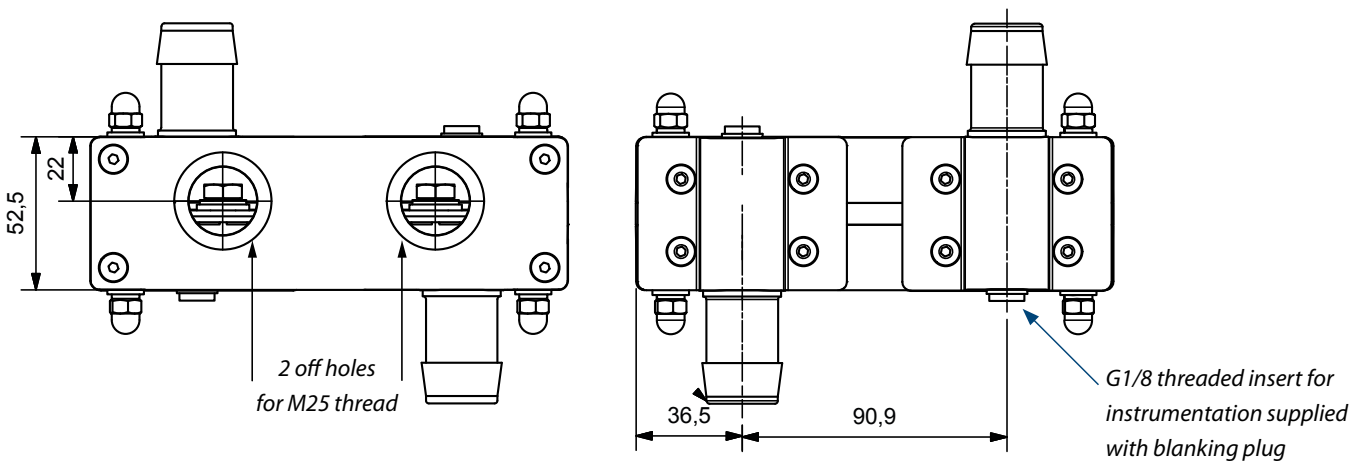

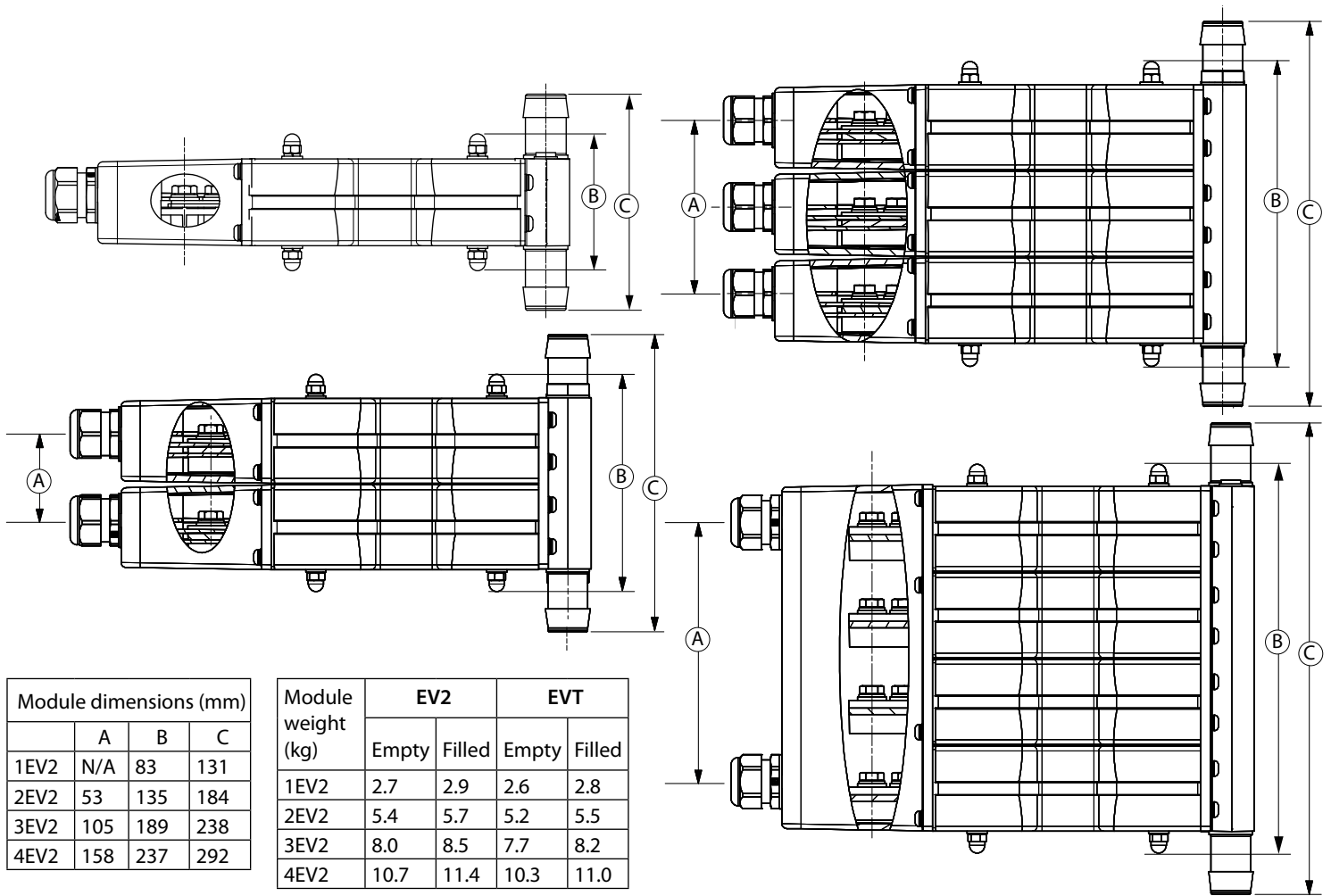

Mounting Options

All EV2 and EVT mounting assemblies are available pre-fitted with filters as well as flow, pressure and temperature sensors and monitoring.



EV2 resistors used to control hoists on board ship. The open back plate assembly holds 2 x 4EV2 assemblies to give a maximum continuous power of 200kW.

Supplied as either open bracket mounted assemblies for installation into existing cabinets or as complete enclosures.

For installation into existing cabinets we can offer:

Open Bank – up to 4xEV modules

- Can accommodate 1 to 4 EV's, 100kW maximum continuous power
- Monitoring: Flow, Pressure and Temperature
- IP56 Rated terminal compartment
- Coolant Inlet/Outlet: 1" flexible hose

Open Bank – up to 8xEV modules

- Can accommodate 2 to 8 EV's, 200kW maximum continuous power
- Other features as above

Complete Enclosure

- Can accommodate up to 24 EV's (6 x 4EV modules), 600kW maximum continuous power.
- Status monitoring relay status displayed on door panel.
- Lockable hinged access doors front and back
- Coolant Inlet/Outlet pipe flange: DN80

Alternatively we can offer complete stand-alone assemblies.

CRESSALL EV2 & EVT advanced water cooled modular resistors

Recommended accessories for EV resistors



1 Flow Meter

- Low pressure drop flow meter
- 0 to 100 l/m input
- Pulsed NPN transistor output
- Supply Voltage: 4.5-24Vdc
- 2 x 1" BSP Male pipe connections

2 Pressure Sensor

- 0 to 5 Bar input
- 4-20mA output
- G1/4 Male threaded connection
- Supply Voltage: 9-32Vdcβ

3 Filter

- In-line Y-strainer Filter
- Filtration to 100µm
- 2 x 1" BSP Female pipe connections



Temperature Sensor

- -40°C to 275°C temperature input
- PT100 or PT1000 type
- M14 x 1.5mm mounting thread

Flow & Temperature Monitor

- 8 x flow sensor inputs
- 8 x temperature sensor inputs
- 8 x per channel status output contact
- 1 x overall flow status output contact
- 1 x overall temperature status output contact
- Supply Voltage: 24Vdc
- Programmable trip points based on EV2 module size(s)

Cressall – power resistors designed and manufactured in the UK for a global market

With more than 100 years' experience designing and manufacturing resistors in the UK, Cressall can supply high power resistors for use in:

- Electricity generation, transmission and distribution
- Renewable energy
- Marine and offshore electrical systems
- High power electrical testing
- Rail traction
- Drives and Automation
- Telecoms
- Oil and Gas
- Automotive

Our equipment is used in some of the most demanding locations around the world for applications such as:

- Neutral earthing resistors for MV and HV electrical supplies
- Dynamic braking resistors for braking inverters and motors
- Portable load banks for testing batteries, generators and UPS systems
- High voltage filter resistors for SVC, capacitor damping networks and HVDC applications
- Load banks for load testing diesel generators and large gas turbines
- Pre-insertion resistors for transformers and high voltage networks
- Braking resistors, control resistors and trackside resistors for rail traction
- Liquid cooled resistors



www.cressall.com

CRESSALL

Evington Valley Road, Leicester, LE5 5LZ, U.K.

Tel: +44 (0) 116 273 3633 • Fax: +44 (0) 116 273 7911

email: sales@cressall.com

© Cressall Resistors Ltd, Evington Valley Road, Leicester, LE5 5LZ, United Kingdom.
Cressall reserve the right to change and improve products and specifications.