

WOLFGANG PUCK

USE AND CARE

Pressure Oven

LIFE IS ABOUT BALANCE
AND EATING WELL

Wolfgang Puck

IMPORTANT NOTICE

If you have any problems with this unit, contact
Consumer Relations for service PHONE: 1-800-275-8273
or visit our website at wphousewares.com

Please read operating instructions before using this
product. Please keep original box and packing materials
in the event that service is required.



W.P. APPLIANCES, INC. Toll Free (800) 275-8273
Model BROR1000-A2 Printed In China REV 1.0

Patent Pending
*Photos and illustrations throughout this manual
may differ slightly from actual product.*

Model BROR1000-A2

IMPORTANT SAFEGUARDS

When using electrical appliances, basic safety precautions should be followed, including:

- 1 Read all instructions.
- 2 The exterior of the oven will become very hot during use. Do not touch hot surfaces. Use handles or knobs.
- 3 Close supervision is necessary when any appliance is used by or near children.
- 4 To protect against electric shock, do not immerse cord, plug, or any parts of the oven in water or other liquids.
- 5 Do not operate appliance with damaged cord or plug or after the appliance malfunctions, or has been damaged in any manner. Call our toll free consumer hotline for information on examination, repair or adjustment.
- 6 The use of accessory attachments not recommended by W.P. Appliances, Inc. may cause hazard or injury.
- 7 Do not use outdoors.
- 8 Do not place on or near a hot gas or electric burner, or in a heated oven or in a microwave oven.
- 9 Do not let the cord hang over the edge of table or counter, or touch hot surfaces, including the stove.
- 10 When operating the oven, keep at least four inches of space on all sides of the oven to allow for adequate air circulation.
- 11 Unplug from outlet when not in use and before cleaning. Allow to cool before putting on or taking off parts, and before cleaning.
- 12 To disconnect, turn the TIMER KNOB to 0 (off), then remove the plug. Always hold the plug, never pull the cord.
- 13 Extreme caution must be used when moving an appliance containing hot oil or other hot liquids.
- 14 Do not clean with metal scouring pads. Pieces can break off the pad and touch electrical parts, creating a risk of electric shock.
- 15 A fire may occur if the oven is covered, touching, or near flammable material, including curtains, draperies, walls, and the like, when in operation. Do not store any item on top of the oven when in operation, or before the oven cools down.
- 16 Extreme caution should be used when using containers other than metal or glass.
- 17 Do not cover CRUMB TRAY or any part of the oven with metal foil. This will cause overheating. Foil can be used to cover approved cooking containers. Do not place any of the following materials in the oven: cardboard, plastic, paper, or anything similar.
- 18 Do not place eyes or face in close proximity with the tempered safety glass door, in the event that the safety glass breaks.
- 19 Use extreme caution when removing trays or disposing of hot grease or other hot liquids.
- 20 Do not store any materials, other than manufacturers recommended accessories, in this oven when not in use.
- 21 This appliance is off when the Timer is in the 0 (off) position. When not in use, the oven should always remain unplugged from the wall outlet.
- 22 Always wear protective, insulated oven mitts when inserting or removing items from the hot oven.

- 23 This appliance has a tempered, safety glass door. The glass is stronger than ordinary glass and more resistant to breakage. Tempered glass can break, but the pieces will not have sharp edges. Avoid scratching door surface or nicking edges. If the door has a scratch or nick, contact our toll-free customer service line before using the oven.
- 24 Do not use appliance for other than intended use.
- 25 Always inspect VENT RELEASE VALVE and make sure it is clean of any food particles or other obstructions
- 26 Before opening door turn VENT RELEASE VALVE to VENT and wait for pressure to dissipate, then raise SEALING LEVER to the STANDARD position.
- 27 Oversize foods or metal utensils must not be inserted in an oven as they may create a fire or risk of electric shock.
- 28 To ensure continued protection against risk of electric shock, connect to properly grounded outlets.

SAVE THESE INSTRUCTIONS HOUSEHOLD USE ONLY

Additional Safety Information

GROUNDING INSTRUCTIONS: This appliance must be grounded. It is equipped with a 3-prong cord having a grounded plug. The plug must be plugged into an outlet which is properly installed and grounded.

Warning: Improper use of the grounded cord can result in the risk of electric shock. Consult a qualified electrician if necessary. Do not attempt to defeat this safety feature by modifying plug.

A short power-supply cord is provided to reduce the hazards resulting from entanglement or tripping over a longer cord. If it is necessary to use an extension cord, it should be positioned such that it does not drape over the counter or tabletop where it can be pulled on by children or tripped over and:

- A. Use only 3-prong extension cord with 3-blade grounding plug.
- B. The marked rating of the extension cord must be equal to or greater than the rating of this appliance. The electrical rating of this appliance is 120V 1,700 watts.

Please take a few minutes to read this manual before using your oven to become familiar with its parts and operation.



Wolfgang Puck, owner of the famous Spago restaurants and one of the most influential chef-restauranteurs in America, is credited with reviving California's rich culinary heritage. His cooking innovations, a result of blending fresh California ingredients with his classical French techniques, are enjoyed by

world leaders, stars and fellow chefs alike. He established other trend-setting restaurants like Postrio in San Francisco, Chinois on Main in Santa Monica, Trattoria del Lupo, Cut, and his latest creation, Jai, an Asian fusion restaurant in San Diego. Home chefs can also share Mr. Puck's talents through his cookbooks, cutlery, cookware and, of course, through his appliances!

Table of Contents

Important Safeguards	2
Additional Safety Information	3
About Wolfgang Puck	4
Introduction	6
Quick Start Guide	6
Know Your Wolfgang Puck Pressure Oven	8
Before Your First Use	10
Become Familiar with Your Oven Parts	10
Use & Care References	13
Operation	15
Bake Function	16
Toast Function	17
Roast Function	18
Broil Function	19
Rotisserie Function	20
Trussing Chicken	22
Warm Function	23
Helpful Hints	23
Cooking Chart	24
Troubleshooting Guide	26
Care & Cleaning	30
Limited Warranty	31
Contact Information	Back

Introduction

Congratulations on your purchase of the Wolfgang Puck Pressure Oven, breakthrough technology in the world of cooking. After years of development, Wolfgang Puck has teamed with KitchenTek to design a superior countertop oven with the perfect blend of time savings and improved performance to make your life easier and your meals even tastier. Low pressure and even heat distribution in a sealed oven chamber allow for faster cooking and improved flavor, without sacrificing moisture. Imagine roasting a 13 pound turkey in under an hour (over 4 hours in a traditional oven). Imagine getting the fullness of baked goods without the need of convection fans or rotating pans.

The brushed stainless steel exterior, easy to read controls, and superior performance are a welcome addition to any kitchen countertop. Please be sure to read all important safeguards of this manual, as well as the helpful hints section to ensure you get all the best this innovative oven has to offer.

Quick Start Guide

Before using this Quick Start Guide, please ensure that you have read the Instruction Manual fully and have become familiar with the import safeguards.

Warning: The oven exterior and door is hot during and after use. To prevent a burn injury, we recommend always using protective hot pads or oven mitts when adding or removing items from the oven.

To cook in PRESSURE Mode:

- 1 Set the FUNCTION KNOB to the desired function and preheat the oven according to the recipe instructions.
- 2 Once preheated, press the DOOR RELEASE BUTTON to open door and add food.
- 3 Close the oven door and lower the SEALING LEVER to the SEAL position.
- 4 Turn the VENT RELEASE VALVE to the SEAL position.
- 5 Set the TIMER KNOB to the desired cooking time.

When cooking is complete in PRESSURE mode (see illustration on right)

- 1 Set the TIMER KNOB to 0 (unless already off).
- 2 Turn the VENT RELEASE VALVE to the VENT position and wait until all steam has released.
- 3 Raise the SEALING LEVER to the STANDARD position.
- 4 Press the DOOR RELEASE BUTTON to open the door.
WARNING! Never attempt to raise the SEALING LEVER or open the door until all steam has been vented from the VENT RELEASE VALVE. Failure to do so could result in a scalding injury.

Quick Start Guide (cont.)

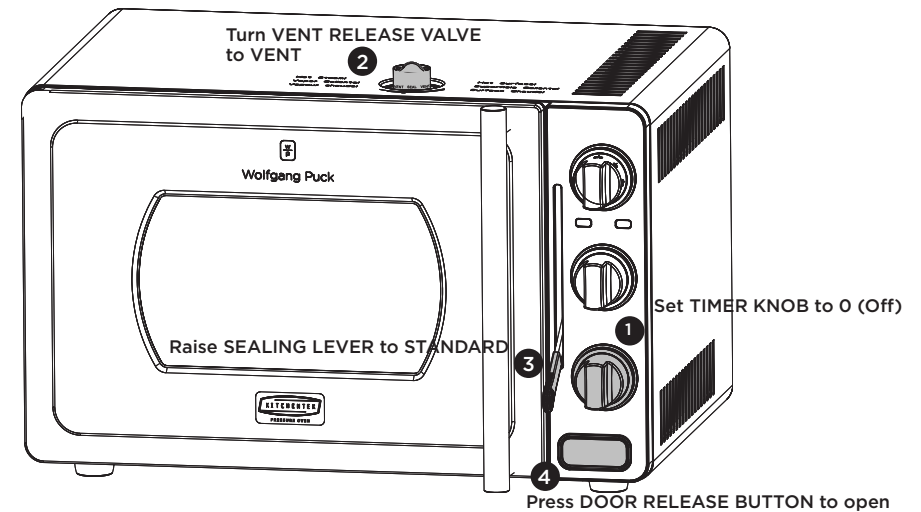

To cook in STANDARD Mode:

Note: When cooking in STANDARD Mode (without pressure) the door will remain slightly ajar on the handle side (see below) to allow the oven to vent freely during cooking.

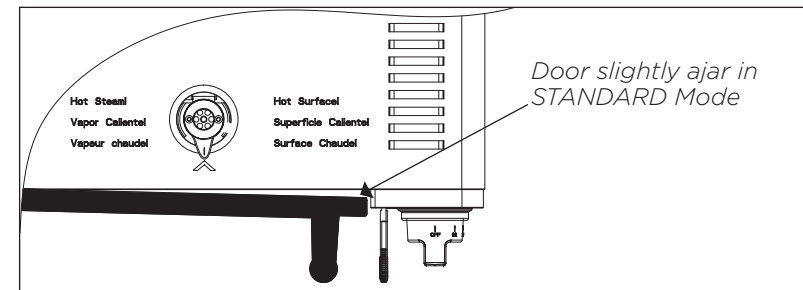

- 1 Set the FUNCTION KNOB to the desired function and preheat the oven according to the recipe instructions.
- 2 Once preheated, press the DOOR RELEASE BUTTON to open door and add food.
- 3 Close the oven door and leave the SEALING LEVER to the STANDARD position.
- 4 Turn the VENT RELEASE VALVE to the VENT position.
- 5 Set the TIMER KNOB to the desired cooking time.
- 6 When cooking is complete, turn the TIMER to 0 (unless already off) and press the DOOR RELEASE BUTTON to open the door.

Know Your Wolfgang Puck Pressure Oven

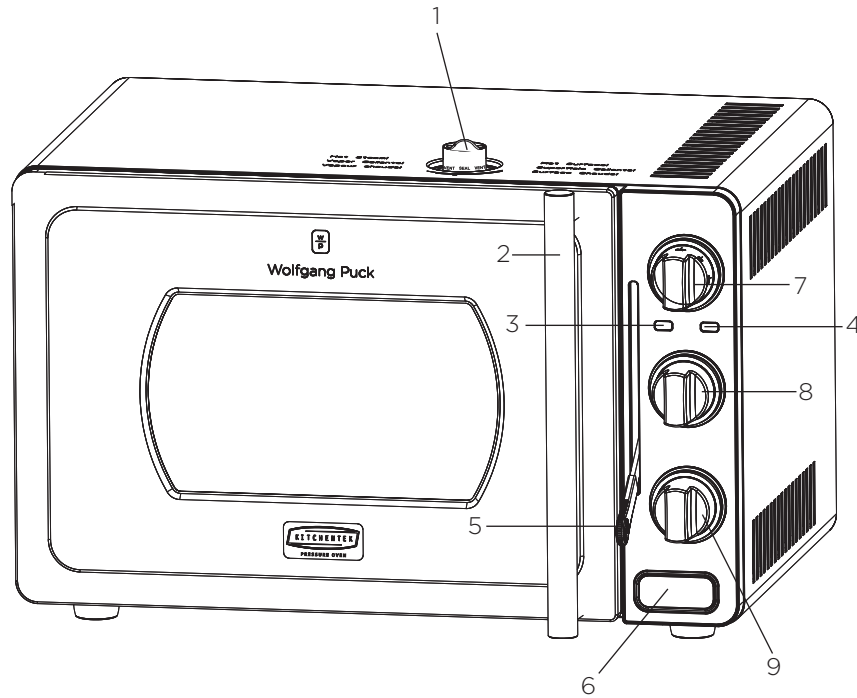

- | | |
|--------------------------|-----------------------------|
| 1. Vent Release Valve | 11. Broil Rack Insert |
| 2. Door Handle | 12. Drip/Baking Pan |
| 3. Power Indicator Light | 13. Roasting Pan |
| 4. Ready Light | 14. Crumb Tray |
| 5. Sealing Lever | 15. Rotisserie Rod |
| 6. Door Release Button | 16. Rotisserie Screws |
| 7. Temperature Knob | 17. Rotisserie Tines |
| 8. Function Knob | 18. Rack Removal Tool |
| 9. Timer Knob | 19. Rotisserie Removal Tool |
| 10. Baking Rack | 20. Control Panel |

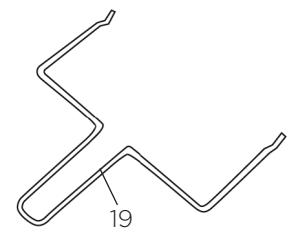
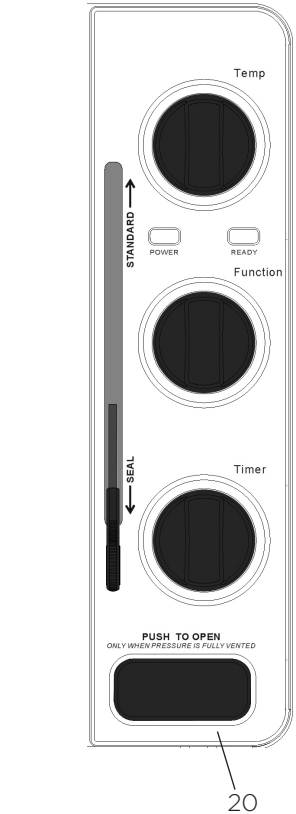
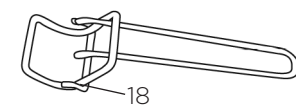
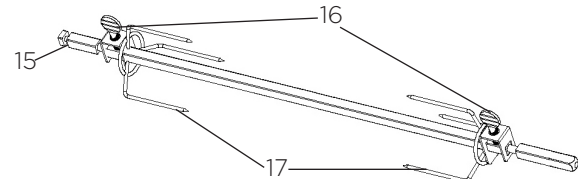
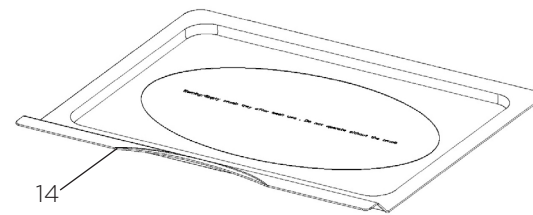
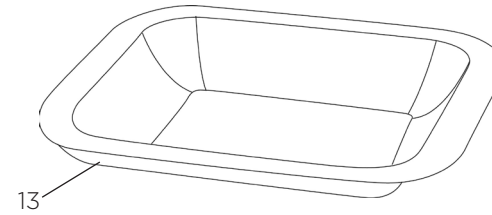
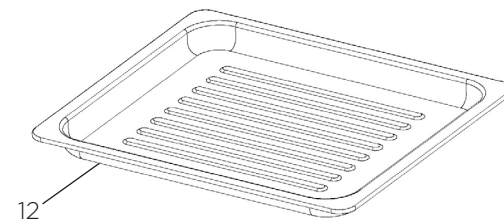
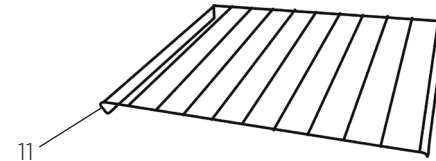
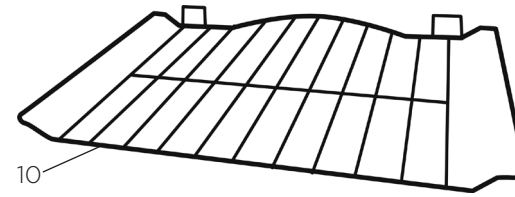

Actual product may differ slightly from illustrations on this page

Before Your First Use

Become familiar with your oven and the functions before plugging in and using. Always unplug your oven and wait until all parts and oven body have completely cooled prior to cleaning. Ensure that you have removed all parts from the packaging materials by referencing the Know Your Oven section of this manual.

It is necessary to do a trial run of your oven to eliminate any protective substance on the heating elements. Conduct the trial run in a well-ventilated area as a small amount of smoke and odor may be detected. This is normal and should be expected. Follow the procedure below for the trial run.

- 1 Remove all accessories from the oven and close the door.
- 2 Ensure the VENT RELEASE VALVE is in the VENT position and the SEALING LEVER is in the STANDARD position.
- 3 Plug the oven into a standard 120v grounded outlet.
- 4 Set the FUNCTION KNOB to BAKE, the TEMPERATURE KNOB to 450°F and the TIMER KNOB to 30 to begin the trial run process.
- 5 When the time has expired reset to 30 minutes and set the FUNCTION KNOB to Rotisserie then repeat trial run process in Rotisserie mode.

Become Familiar with Your Oven Parts

Temperature Knob

Choose the desired or recommended temperature up to 450°F.

Function Knob

Select from one of the six available cooking modes (Bake, Toast, Roast, Broil, Rotisserie, Warm).

Timer Knob

When you turn the knob to the left (counterclockwise) to the “Stay On” position, the oven will remain on until it is manually shut off. To activate the 120 minute timer, turn the TIMER KNOB to the right (clockwise). When the time has elapsed or the knob is manually turned to the 0 (off) position, a bell will sound and oven will shut off.

Note: For times shorter than 20 minutes, or when toasting, turn the TIMER KNOB past the 30 minute mark and then back to the desired time.

Power Indicator Light (Red)

Illuminates when the “Stay On” mode or TIMER KNOB is turned on.

Become Familiar with Your Oven Parts (cont.)

Ready Light (Green)

Illuminates when the oven has preheated to the set temperature, and will cycle on and off during the cooking cycle while maintaining the set temperature.

Baking Rack

The curved portion of the BAKING RACK should be placed at the rear of the oven with the two brackets in the up position (see fig. 1 on page 13).

Drip/Baking Pan and Broil Rack Insert

Always place on top of the baking rack in the bottom rack position when using the rotisserie mode (see fig. 2 on page 13 - shaded for reference only). Use as a drip pan when broiling in the upper rack position when combined with the DRIP/BAKING PAN INSERT (see fig. 3 on page 13 - shaded for reference only). The pan can be used as a baking pan when placed on top of the BAKING RACK.

Crumb Tray

To access the CRUMB TRAY open the door and slide out from underneath the bottom heating elements. Always have the CRUMB TRAY in place underneath the heating elements when using your oven.

Rotisserie Rod with Screws & Tines

Slide ROTISSERIE TINES pointed toward the center of the ROTISSERIE ROD. Ensure that ROTISSERIE SCREWS are tightened prior to placing in oven.

Rotisserie Rod Removal Tool

Place tool under ROTISSERIE ROD and lift the left side up and forward, then slightly to the left to remove the roast from the oven.

Baking Rack/Drip Pan Removal Tool

Used to remove the BAKING RACK or DRIP PAN from the oven. It is not recommended to be used when lifting heavy casserole dishes.

Become Familiar with Your Oven Parts (cont.)

Vent Release Valve

Used to maintain low pressure (1 psi) in the oven during the cooking process. The VENT RELEASE VALVE has two settings, SEAL (see fig. 4 on page 14) to maintain the pressure, and VENT (see fig. 5 on page 14) to release pressure at the end of the cooking process.

NOTE: By design the VENT RELEASE VALVE rests loosely on top of the vent valve. This allows the VENT RELEASE VALVE to rise up and down during the cooking process to maintain the proper pressure.

Sealing Lever

Your oven has the ability to cook in standard toaster oven mode or in pressure mode. To cook in standard mode leave the SEALING LEVER in the up position STANDARD (see fig. 6 on page 14) and the VENT RELEASE VALVE in the VENT position (see fig. 5 on page 14). To cook in pressure mode, lower the SEALING LEVER to the SEAL position (see fig. 7 on page 14) and the VENT RELEASE VALVE to the SEAL position (see fig. 4 on page 14).

Door Release Button

Press the DOOR RELEASE BUTTON to open the oven door. Do not attempt to pull the door open without using the DOOR RELEASE BUTTON.

Use & Care References

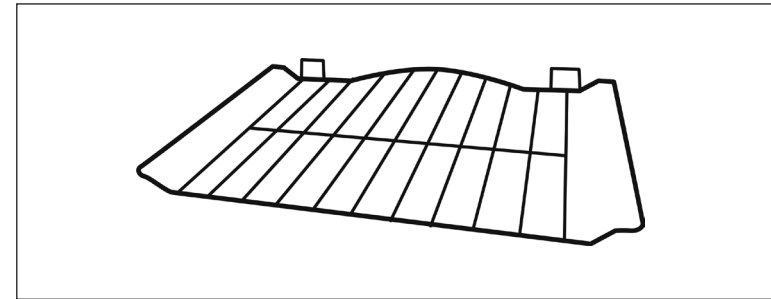

Figure 1

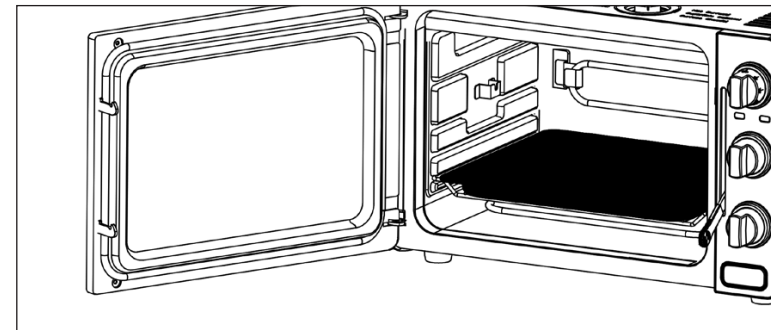

Figure 2

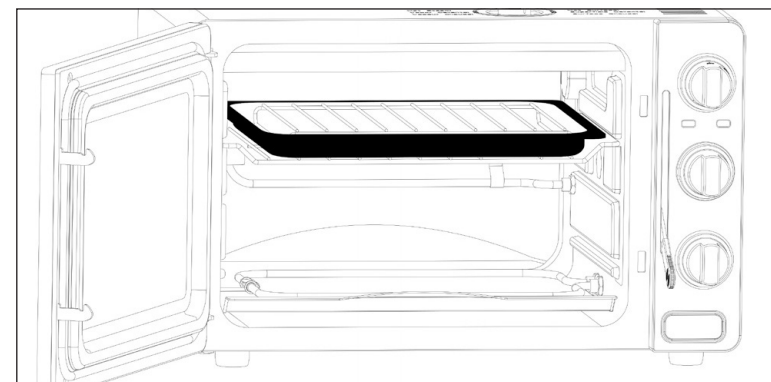

Figure 3

Use & Care References

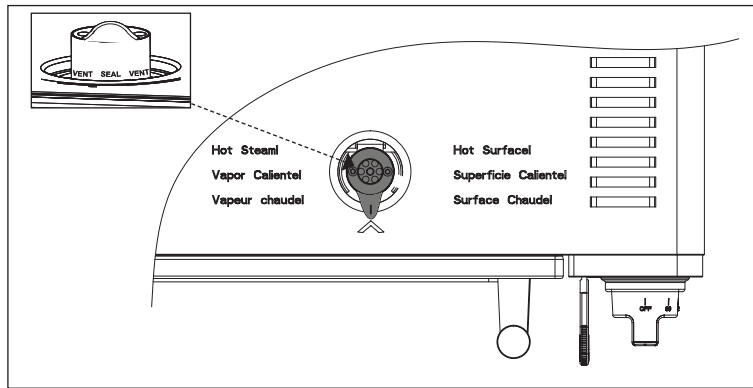

Figure 4

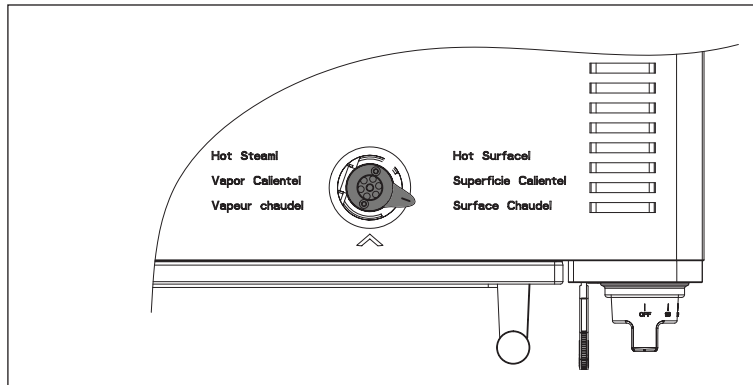

Figure 5

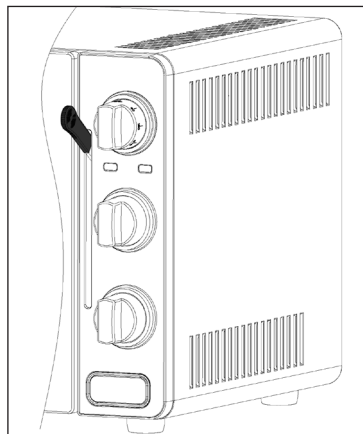

Figure 6

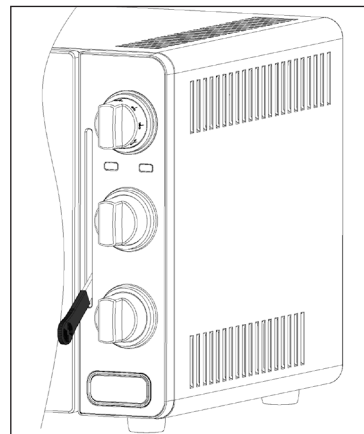

Figure 7

Operation

Caution: Appliance surfaces are hot during and after use! Do not touch hot surfaces. Use handles or knobs. Do not store or place any other item on top of the oven.

- Be sure that the TIMER KNOB is set to 0 (off) before plugging the cord into the outlet for use and when unplugging the oven after use.
- The heating element located on the inner back wall of the oven operates in ROTISSERIE mode only.
- Set the TEMPERATURE KNOB and the FUNCTION KNOB before setting the TIMER KNOB.
- The oven will only operate if the TIMER KNOB is turned to a time setting or if it is in the "Stay On" position.

Cooking Containers:

- The DRIP/BAKING PAN included with the oven is suitable for cookies, rolls, biscuits, nachos, pork chops, etc.
- Most standard baking pans and casserole dishes are suitable for oven. The width should not exceed 14 inches and the depth should not exceed 12 inches.
- Choose bakeware made of metal, oven-proof glass or ceramic. Check for Wolfgang Puck bakeware on HSN.com.
- Many convenience foods are packaged in nonmetallic containers suitable for use in microwave ovens as well as regular ovens. Check package directions carefully to determine if the container is suitable for use in a regular oven.

Bake Function

STANDARD Mode:

In Bake mode, both the top and bottom heating elements operate without the rear heating element. The heating elements will cycle on and off to maintain the selected temperature.

In most cases you should use the lowest rack position; however, if more browning is desired, place in the upper rack position. The DRIP/BAKING PAN included with your oven can be used for baking. It is enamel-coated, making it easy to clean.

- 1 Ensure the SEALING LEVER is in the STANDARD position and the VENT RELEASE VALVE is in the VENT position.
- 2 Place the BAKING RACK in the desired rack position.
- 3 Set the FUNCTION KNOB to BAKE.
- 4 Set the TEMPERATURE KNOB to the recommended temperature.
- 5 Set the TIMER KNOB to the shortest baking time in the recipe after the oven is preheated.
- 6 When the TIMER has expired or you have set it to the 0 (off) position, press the DOOR RELEASE BUTTON to open the door.

PRESSURE Mode:

- 1 Follow steps 1 thru 5 above.
- 2 Set the VENT RELEASE VALVE to SEAL, and lower the SEALING LEVER to the SEAL position.
- 3 When the Timer has expired or you have set it to the 0 (off) position, move the VENT RELEASE VALVE to the VENT position and wait for the pressure to dissipate. When all pressure has been released, raise the SEALING LEVER to the STANDARD position and press the DOOR RELEASE BUTTON to open the door.

CAUTION: To prevent a burn injury, never attempt to force the door open or raise the SEALING LEVER without first venting the oven. Always keep hands and face away from door opening as hot air is released from oven upon opening.

Note: If additional cooking time is required, place the food back into the oven, set the VENT RELEASE VALVE back to SEAL, and lower the SEALING LEVER to the SEAL position. Pressure will restore immediately.

Toast Function

STANDARD Mode:

In Toast mode, both the top and bottom heating elements operate without the rear heating element. The heating elements will cycle on and off to maintain the selected temperature.

It is not necessary to Toast in pressure mode, standard mode will provide even toasting.

- 1 Ensure the SEALING LEVER is in the STANDARD position and the VENT RELEASE VALVE is in the VENT position.
- 2 Place the BAKING RACK in the middle position.
- 3 Set the FUNCTION KNOB to TOAST.
- 4 Set the TEMPERATURE KNOB to 450°F.
- 5 Turn the TIMER KNOB past the 30 minute mark and then back to the center of the first two dashes of the TIMER KNOB (10 minutes)

The toast will reach a light shade in 7 minutes and a dark shade in 8.5 minutes. Toast shade is subjective so turn the TIMER KNOB to the 0 position (off) when your desired shade is reached.

Roast Function

STANDARD Mode:

In Roast mode, both the top and bottom heating elements operate without the rear heating element. The heating elements will cycle on and off to maintain the selected temperature.

In most cases you should use the middle rack position; however, ensure that food being roasted does not contact the upper heating elements.

- 1 Ensure the SEALING LEVER is in the STANDARD position and the VENT RELEASE VALVE is in the VENT position.
- 2 Place the BAKING RACK, with the drip pan placed underneath, in the desired rack position.
- 3 Set the FUNCTION KNOB to ROAST.
- 4 Set the TEMPERATURE KNOB to the recommended temperature.
- 5 Set the TIMER KNOB to the shortest roasting time in the recipe after the oven is preheated.
- 6 When the TIMER has expired or you have set it to the 0 (off) position, press the DOOR RELEASE BUTTON to open the door.

PRESSURE Mode:

- 1 Follow steps 1 - 5 above.
- 2 Set the VENT RELEASE VALVE to SEAL, and lower the SEALING LEVER to the SEAL position.
- 3 When the Timer has expired or you have set it to the 0 (off) position, move the VENT RELEASE VALVE to the VENT position and wait for the pressure to dissipate. When all pressure has been released, raise the SEALING LEVER to the STANDARD position and press the DOOR RELEASE BUTTON to open the door.

CAUTION: To prevent a burn injury, never attempt to force the door open or raise the SEALING LEVER without first venting the oven. Always keep hands and face away from door opening as hot air is released from oven upon opening.

Note: If additional cooking time is required, place the food back into the oven, set the VENT RELEASE VALVE back to SEAL, and lower the SEALING LEVER to the SEAL position. Pressure will restore immediately.

Broil Function

STANDARD Mode:

The top heating elements, excluding the rear element, cycle on and off to maintain the set temperature. For best results, the oven should be preheated for 10 minutes before adding the food to be broiled. If adding barbecue or other sweet sauces they should be brushed on during the last 15 minutes of broiling. They will burn if applied too early in the cooking.

- 1 Ensure the SEALING LEVER is in the STANDARD position and the VENT RELEASE VALVE is in the VENT position.
- 2 Place the BAKING RACK with the DRIP/BAKING PAN placed underneath in the upper rack position.
- 3 Set the FUNCTION KNOB to BROIL.
- 4 Set the TEMPERATURE KNOB to 450°F.
- 5 Set TIMER KNOB to the shortest broiling time in the recipe after the oven is preheated. Do not use the STAY ON function in BROIL mode.
- 6 When the TIMER has expired or you have set it to the 0 (off) position, press the DOOR RELEASE BUTTON to open the door.

PRESSURE Mode:

- 1 Follow steps 1 - 5 above.
- 2 Set the VENT RELEASE VALVE to SEAL, and lower the SEALING LEVER to the SEAL position.
- 3 When the Timer has expired or you have set it to the 0 (off) position, move the VENT RELEASE VALVE to the VENT position and wait for the pressure to dissipate. When all pressure has been released, raise the SEALING LEVER to the STANDARD position and press the DOOR RELEASE BUTTON to open the door.

CAUTION: To prevent a burn injury never attempt to force the door open or raise the SEALING LEVER without first venting the oven. Always keep hands and face away from door opening as hot air is released from oven upon opening. DO NOT leave the oven unattended during broiling.

Note: If additional cooking time is required, place the food back into the oven, set the VENT RELEASE VALVE back to SEAL, and lower the SEALING LEVER to the SEAL position. Pressure will restore immediately.

Rotisserie Function

STANDARD Mode:

The top heating element cycles on and off while the rear heating element stays on to maintain the set temperature in the oven while the spit continually turns.

Rotisserie roasting is a healthy way to cook meats because the slow-turning spit provides natural basting of meats while fats drip away. The rotisserie can be used to roast meats up to 6 pounds. It is not necessary to preheat the oven for rotisserie roasting.

CAUTION: Never use the rotisserie mode without the DRIP PAN assembled underneath the BAKING RACK in the bottom rack position.

- 1 Ensure the SEALING LEVER is in the STANDARD position and the VENT RELEASE VALVE is in the VENT position.
- 2 Place one ROTISSERIE TINE on the end of the ROTISSERIE SPIT with the ROTISSERIE TINES facing the center and tighten the ROTISSERIE SCREW.
- 3 Slide the solid end of the ROTISSERIE ROD through the center of the food to be cooked.
- 4 Place the other ROTISSERIE TINE on the other end of the ROTISSERIE ROD with the ROTISSERIE TINES facing the roast.
- 5 Adjust the roast so that it is centered on the ROTISSERIE ROD. Make sure the ROTISSERIE TINES secure the roast on the ROTISSERIE ROD and tighten the ROTISSERIE SCREWS.
- 6 When cooking poultry, it is necessary to secure legs and wings to the body with string to make the roast as compact as possible for smooth movement of the ROTISSERIE ROD.
- 7 Season or baste the roast as desired.
IMPORTANT! Place the DRIP/BAKING PAN in the rails on the bottom of the oven to catch the drippings.
- 8 Put the solid end of the ROTISSERIE ROD in the drive socket on right interior wall of the oven.
- 9 Place the grooved end on the ROTISSERIE on the left interior wall of the oven.
- 10 Set the TEMPERATURE KNOB to 450°.
- 11 Set the FUNCTION KNOB to Rotisserie.
- 12 Set the TIMER KNOB to the shortest time. If more than 2 hours, set to "Stay On" and check after the shortest time.
- 13 When the TIMER has expired or you have set it to the 0 (off) position, press the DOOR RELEASE BUTTON to open the door.
- 14 Remove the assembled ROTISSERIE ROD from the oven using the ROTISSERIE REMOVAL TOOL included.
- 15 Place the roast on a cutting board or platter and allow to stand for 10-15 minutes.
- 16 Using a pot holder, loosen the ROTISSERIE SCREWS on the ROTISSERIE TINES and remove the ROTISSERIE ROD from the roast. Carefully remove the ROTISSERIE TINES and carve the roast.

Rotisserie Function (cont.)

Pressure Mode:

- 1 Follow steps 1 – 11 from Rotisserie Function (Standard Mode)
Set the VENT RELEASE VALVE to SEAL, and lower the SEALING LEVER to the SEAL position.
- 2 LEVER to the SEAL position.
- 3 When the TIMER has expired or you have set it to the 0 (off) position, move the VENT RELEASE VALVE to the VENT position and wait for the pressure to dissipate. When all pressure has been released, raise the SEALING LEVER to the STANDARD position and press the DOOR RELEASE BUTTON to open the door.

CAUTION: To prevent a burn injury, never attempt to force the door open or raise the SEALING LEVER without first venting the oven. Always keep hands and face away from door opening as hot air is released from oven upon opening.

- 4 Remove the ROTISSERIE ROD from the oven using the ROTISSERIE REMOVAL TOOL included.
- 5 Place the roast on a cutting board or platter and allow to stand for 10-15 minutes.
- 6 Using a pot holder, loosen the ROTISSERIE SCREWS on the ROTISSERIE TINES and remove the ROTISSERIE ROD from the roast. Carefully remove the ROTISSERIE TINES and carve the roast.

Note: If additional cooking time is required, place the food back into the oven, set the VENT RELEASE VALVE back to SEAL, and lower the SEALING LEVER to the SEAL position. Pressure will restore immediately.

Trussing Chicken

Items needed to truss chicken: 2 feet butchers twine (approximate)
Scissors or knife



Place the chicken on a cutting board breast up. Place twine under wings of the chicken then pull the twine evenly between legs and breast.

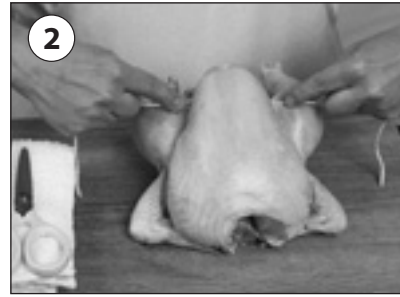

Cross the Twine.



Run the twine under the end of the chicken legs.

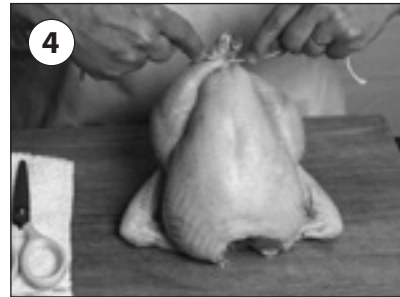

Wrap the twine up and around legs and bring them together, then tie the twine into a knot and then a bow to secure.



Run Rotisserie Rod through the cavity of the chicken. Then secure the Rotisserie Tine between the legs and into the back of the chicken and tighten down the screw on the Rotisserie Tine.



Place the other Rotisserie Tine on the Rotisserie Rod already in the chicken. Slide down and secure the Rotisserie Tine into both sides of the chicken breast. Tighten down the screw on the Rotisserie Rod. Load chicken into oven.

Warm Function

It is not necessary to use the WARM function in pressure mode.

STANDARD Mode:

- 1 Ensure the SEALING LEVER is in the STANDARD position and the VENT RELEASE VALVE is in the VENT position.
- 2 Place the BAKING RACK in the lower or middle rack position.
- 3 Set the FUNCTION KNOB to WARM.
- 4 Set the TEMPERATURE KNOB to 175 °F (line between 150 and 200 °F).
- 5 Set the TIMER KNOB as desired.

Helpful Hints

- Your oven can be used in standard conventional mode or pressure mode. In conventional mode, there is no need to change recipe cooking times or temperature. In pressure mode, cooking times will be shorter depending upon type of food being cooked. See the various cooking charts, guidelines, and recipes throughout this manual for adjusted cooking times in pressure mode, then experiment with your own favorite recipes.
- When roasting meats, it is always best to use the middle rack position being sure that your food does not contact the upper heating elements. This will ensure better caramelization of your meats.
- Always preheat your oven to the desired temperature before adding food.
- It is not necessary to rotate foods halfway through cooking cycle as your oven provides even heat distribution.
- Water can be added directly to the DRIP/BAKING PAN for foods such as fish and vegetable to provide steam.
- For better results, you should always bake food that has been thoroughly thawed. The only exception to this is rule is when baking packaged frozen dinners and/or pizzas. Follow the manufacturer's instructions for required time.
- Always distribute the food evenly around the inside of the oven. Give equal space around the pans as well as above and below.
- Rules of thumb when cooking in pressure mode: poultry cooks about 70% faster; roasts (beef, pork, etc.) cook about 50% faster; casseroles, vegetables and baked goods cook about 25% faster. If you are not sure, underestimate the cook time and check the temperature before eating. Always cook meats to the internal temperature recommended by the US FDA.

Note: If additional cooking time is required in Pressure Mode, place the food back into the oven, set the VENT RELEASE VALVE back to SEAL, and lower the SEALING LEVER to the SEAL position. Pressure will restore immediately.

Cooking Chart

Cooking Chart (cont.)

Type	Weight	Rack	PRESSURE MODE		STANDARD MODE		US-FDA RECOMMENDED Internal Temp (F)	
			Temp (F)	Time	Temp (F)	Time		
POULTRY								
Chicken (Whole)	3-4 lbs	Middle	450	35 min	350	2 hrs	165	
Chicken (Whole)	5-6 lbs	Middle	450	40 min	350	2 to 2hrs 15min	165	
Chicken (Whole)	7-8 lbs	Bottom	450	43 min	350	2 to 2 1/4 hrs	165	
Chicken - 8pc Barbecue	3-4 lbs	Middle	450	20 min	350	1 hr	165	
Chicken - Butterflied	4 lbs	Middle	450	25 min	350	1 hr	165	
Chicken Breast, Boneless	< 1 lb	Middle	450	9 min	350	30-40 min	165	
Chicken Breast, Boneless	1-2 lbs	Middle	450	10 min	350	40-45 min	165	
Chicken Parts (Legs, Thighs)	3 lbs	Middle	450	31 min	350	45 min	165	
Chicken Parts (Legs, Thighs)	5 lbs	Middle	450	35 min	350	50 min	165	
Turkey, Unstuffed	9-10 lbs	Bottom	450	45 min	325	2hrs 45min to 3hrs	165	
Turkey, Unstuffed	11-12 lbs	Bottom	450	49 min	325	3 hrs	165	
Turkey, Unstuffed	13-14 lbs	Bottom	450	55 min	325	3hrs to 3hrs 45min	165	
Turkey Breast	4-5 lbs	Middle	450	45 min	325	1 hr 40 min	165	
Turkey Breast	6-7 lbs	Middle	450	45 min	325	2 hrs 20 min	165	
BEEF								
Roast Beef (Eye Round)	2-3 lbs	Bottom	450	60 min	325	2 hrs	145	
Roast Beef (Eye Round)	4-5 lbs	Bottom	450	78 min	325	2 hrs 30 min	145	
Roast Beef (Eye Round)	6-7 lbs	Bottom	450	81 min	325	3 hrs 45 min	145	
Prime Rib	6.5 lbs	Bottom	450	90 min	400	2 hrs 30 min	145	
Braised Beef	4-5 lbs	Middle	375	2hrs 30min	325	3 hrs 30 min	145	
Ribeye Steak	10-12 oz	Upper	450	10 min	450	15 min	145	
PORK								
Pork Roast (Shoulder)	2-3 lbs	Middle	325	41 min	325	60 min	145 ¹	
Pork Roast (Shoulder)	4-5 lbs	Middle	325	46 min	325	1 hr 40 min	145 ¹	
Pork Roast (Shoulder)	6-7 lbs	Middle	325	49 min	325	2 hrs 10 min	145 ¹	
Fresh Ham (Shank)	10-11 lbs	Bottom	350	3 hrs	350	3.5-4 hrs	145 ¹	
Pork Loin	4-5 lbs	Middle	450	35 min	325	1 hr 15 min	145 ¹	
FISH								
Salmon Filet	< 1 lb	Middle	450	7 min	400	10-12 min	As Desired	
Salmon Filet	1-2 lbs	Middle	450	9 min	400	18-20 min	As Desired	

¹According to the US FDA cook pork, roasts, and chops to 145°F as measured with a food thermometer before removing meat from the heat source, with a three-minute rest time before carving or consuming. This will result in a product that is both safe and at its best quality - juicy and tender. Visit www.foodsafety.gov for more tips.

Troubleshooting Guide

Troubleshooting Guide (cont.)

Problem	Cause	Solution
Oven does not turn on	Unit is not plugged in, or circuit breaker is tripped	Ensure that your Wolfgang Puck Pressure Oven is plugged into a proper 120V A.C. grounded outlet. If your unit still does not turn on check the circuit breaker or fuse for the outlet you are using and ensure that it is closed. Your oven uses 1,700 watts and should be the only appliance in the outlet.
	Timer is not engaged	Ensure that the Timer is on STAY ON mode or is set to a specific time. For times less than 20 minutes, turn the Timer past the 30 minute mark, and then back to the desired time
I see smoke and notice an odor when I turn my oven on	A protective coating is applied to the heating elements prior to shipment	Conduct a trial run according to page 10 of your manual to ensure that all smoke and odor is burned
	Grease or food particles have come in contact with the heating elements	Ensure that your food does not contact the heating elements while cooking
	Excess grease and food particles are on crumb tray	Unplug the oven and wait for it to completely cool. Remove any residual grease or food particles from the crumb tray
	Grease or food particles are on the heating element	Unplug the oven and wait for it to completely cool. Do not use any cleaning chemical or excessive force on the heating element, simply wipe gently with a cloth to remove any stuck on food from the element, Grease will burn off during use and it is not necessary to attempt to remove. NEVER attempt to wipe elements while the oven is plugged in or still on.
Door does not appear to shut completely	Your oven is currently set to Standard mode	In standard cooking mode (Sealing Lever in up position and Vent Release Valve in VENT position) the door is slightly ajar to allow excess air to vent during cooking from the door. This allows your oven to operate like standard conventional countertop ovens. In pressure mode, the door is pulled in when the Sealing Lever is lowered to complete an airtight seal. See page 12 for additional information.
I hear air escaping from the Vent Release Valve on top of the oven	The Sealing Lever is in pressure mode (Lowered) which forces air through the vent valve to maintain the required pressure in the oven	As pressure builds up when cooking in Pressure Mode, it is normal to hear air escaping from the Vent Release Valve on top of the oven. This is how the oven maintains the correct pressure level.

Troubleshooting Guide (cont.)

Problem	Cause	Solution
Rotisserie motor does not turn	Function Knob is not in Rotisserie mode	Turn the Function Knob so that the Rotisserie function is in the 12:00 o'clock position. See page 20 for additional information.
	Timer Knob is not engaged	Ensure that the Timer Knob is on STAY ON mode or is set to a specific time. For times less than 20 minutes, turn the Timer past the 30 minute mark, and then back to the desired time
I cannot open the door	The Sealing Lever is in the SEAL position	Turn the TIMER KNOB to 0 (unless already off). Rotate the VENT RELEASE VALVE to the VENT position and wait until all steam has released. Raise the SEALING LEVER to the STANDARD mode. Press the DOOR RELEASE BUTTON to open the door. WARNING! Never attempt to raise the SEALING LEVER or open the door until all steam has been vented from the VENT RELEASE VALVE. Failure to do so could result in a scalding injury.
I hear a metal popping noise in the oven	The oven is building pressure inside the cavity	This is a normal occurrence when cooking in pressure mode
The Green ready light keeps turning on and off.	Your Wolfgang Puck Pressure Oven is able to maintain the set temperature without the heating elements being on 100% of the time. During the cooking process the green light cycles on and off as the heating elements cycle on and off.	Ensure the oven's VENT RELEASE VALVE is in the SEAL position, the SEALING LEVER is in the SEAL position, and the Temperature Knob is set per chart or recipe.
My cooking times differ from the cooking times in the charts or recipes	The oven is not set to Pressure Mode	Ensure the oven's VENT RELEASE VALVE is in the SEAL position, the SEALING LEVER is in the SEAL position, and the Temperature Knob is set per chart or recipe.
	Opening door during cooking process	Do not open the door excessively during the cooking process. Use the time in the cooking chart or recipe and check the temperature once the shortest cooking time has expired
	Timer Expired	The Pressure Oven will shut off automatically once the timer has expired. Ensure that the proper amount of time was set on the timer. For times greater than 2 hours set the timer to STAY ON mode and use a separate kitchen timer.
	Size, weight, moisture content and initial temperature of the food to be cooked can alter the final cooking times of almost all foods.	The times and charts throughout the manual are general guidelines only; adjust cooking times to desired doneness. Meats and poultry should be cooked to final safe temperature as indicated by an instant read thermometer
The Vent Release Valve does not turn	The Vent Release Valve is not flush with the oven housing	Turn the Timer knob to the Off position and unplug the oven. Using a hand towel or oven mitt grasp the Vent Release Valve tab and apply downward pressure while twisting left and right. Contact customer service for replacement part. CAUTION: Oven surfaces are hot, do not attempt to vent the oven without adequate protection for your hand.

Care & Cleaning

Ensure that your oven is unplugged and all parts are cool prior to cleaning.

Do not clean with metal scouring pads. Pieces can break off the pad and touch electrical parts, creating a risk of electric shock.

To protect against electric shock, do not immerse cord, plug, or housing of the oven in water or other liquids.

Wash the following parts in warm soapy water or in the dishwasher:

- Baking/Drip Pan
- Baking/Broil Rack
- Rotisserie Rod with tines and screws (fully assemble if placed in dishwasher)
- Roasting Pan
- Crumb Tray
- Rotisserie Removal Tool
- Rack Removal Tool

The interior of your oven can be cleaned with a damp soapy cloth. For stubborn stains, you can apply some oven cleaner to a damp sponge or cloth. Do not attempt to move heating elements during cleaning. The sealing gasket should always be inspected for damage such as tears, or if dislodged. Use gentle pressure to wipe sealing gasket as needed.

Limited Warranty

This warranty covers all defects in workmanship or materials in the mechanical and electrical parts, arising under normal usage and care, in this product for a period of 12 months from the date of purchase provided you are able to present a valid proof-of-purchase. A valid proof-of-purchase is a receipt specifying item, date purchased, and cost of item. A gift receipt with date of purchase and item is also an acceptable proof-of-purchase. Product is intended for household use only. Any commercial use voids the warranty.

This warranty covers the original retail purchaser or gift recipient. During the applicable warranty period within normal household use, we will repair or replace, at our discretion, any mechanical or electrical part which proves defective, or replace unit with a comparable model. To obtain service under the terms of this warranty call Toll Free (800) 275-8273

THIS LIMITED WARRANTY COVERS UNITS PURCHASED AND USED WITHIN THE UNITED STATES AND DOES NOT COVER:

- Damages from improper installation.
- Defects other than manufacturing defects.
- Damages from misuse, abuse, accident, alteration, lack of proper care and maintenance, or incorrect current or voltage.
- Damage from service by other than an authorized dealer or service center.

This warranty gives you special legal rights and you may also have other rights to which you are entitled which may vary from state to state. Shipping and handling charges may apply.