

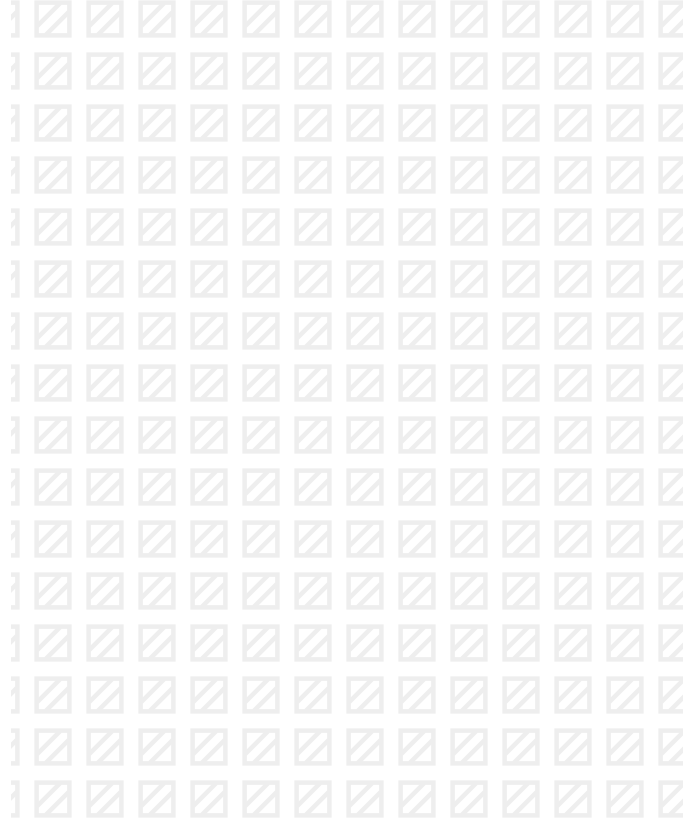

STONE & CLASSIC
COLLECTION



PIETRA REGALE



PIETRA REGALE

Il carattere sobrio e al tempo stesso deciso della Pietra di Luserna (da secoli fiore all'occhiello dell'architettura piemontese, impiegata in edifici simbolo della sua storia, dalla Reggia di Venaria alla Mole Antonelliana) rivive in **PIETRA REGALE**. Una collezione che interpreta questo nobile materiale con gusto contemporaneo e ne amplifica le potenzialità progettuali grazie alle caratteristiche uniche del grès porcellanato in termini di versatilità, resistenza e praticità. 5 colori, in 3 spessori, per un design che sa coniugare diversi contesti e destinazioni d'uso, indoor e outdoor, immagine e sostanza, tradizione e innovazione.

The sober and at the same time strong character of the Pietra di Luserna (for centuries the pride of Piemontese architecture, used in buildings that symbolize its history, from the Reggia di Venaria to the Mole Antonelliana) lives again in **PIETRA REGALE**. A series that represents this noble material with a contemporary taste and amplifies its project-planning potential thanks to the unique characteristics of porcelain tile for versatility, strength and functionality. 5 colours, in 3 thicknesses, for a design that combines different contexts and uses, indoor and outdoor, image and substance, tradition and innovation.

Le caractère à la fois sobre et décisif de la Pierre de Luzerne (depuis des siècles la fierté de l'architecture piémontaise, utilisée dans des bâtiments qui sont des symboles de son histoire, de la Reggia di Venaria à la Mole Antonelliana) revit dans **PIETRA REGALE**. Une collection qui interprète ce matériau noble avec un goût contemporain et qui amplifie son potentiel de conception grâce aux caractéristiques uniques du grès cérame en termes de polyvalence, de résistance et de praticité. 5 couleurs, en 3 épaisseurs, pour un design qui sait combiner différents contextes et usages, indoor et outdoor, image et substance, tradition et innovation.

Der trockene aber gleichzeitig kräftige Charakter der Pietra di Luserna (seit Jahrhunderten Stolz der piemontesischen Architektur, in historisch symbolischen Bauten verwendet, wie die Reggia di Venaria und Mole Antonelliana) lebt in der **PIETRA REGALE** wieder auf. Eine Serie, die dieses noble Material mit modernen Charme umkleidet und dessen Anwendung für Projekte interessanter macht, dank der bekannten Eigenschaften von Feinsteinzeug wie Vielseitigkeit, Belastbarkeit und Zweckmäßigkeit. 5 Farben in 3 Stärken für ein Design, in der Lage unterschiedliche Kontexte und Anwendungsbereiche zu konjugieren, wie Indoor und Outdoor, Image und Substanz, Tradition und Innovation.

100% Made in Italy





RIVOLI 60x60 / 60 x120 Nat. Ret.



OSTANA 60x120 20 mm Nat Ret. R11





FORMATI

Sizes / Formats / Formate

10 mm . 90x90 - 35½"x35 ½" / 45x90 - 18"x35 ½" / 60x120 - 24"x48" / 60x60 - 24"x24" / 30x60 - 12"x24"
10 mm R11. 45x90 - 18"x35 ½" / 30,2x60,4 - 12"x24"
20 mm R11. 90x90 - 35½"x35 ½" / 60x120 - 24"x48" / 60x60 - 24"x24"
30 mm R11. 90x90 - 35½"x35 ½" / 60x60 - 24"x24"

COLORI

Colours / Couleurs / Farben



ELVA



RIVOLI

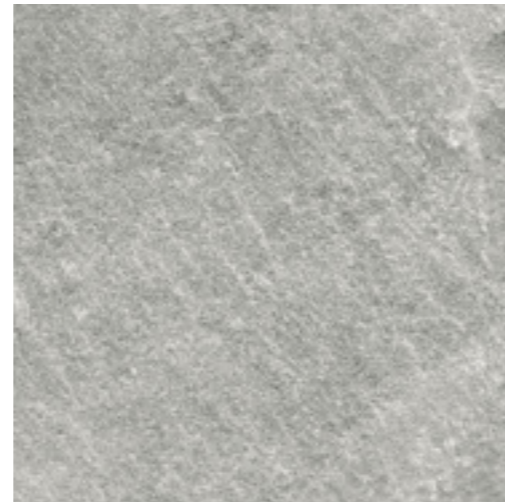

OSTANA



CHIANALE

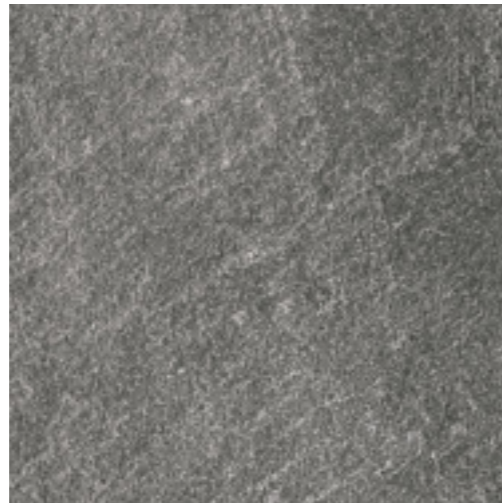

MURAZZANO

CONTINUITÀ PROGETTUALE INDOOR-OUTDOOR

Design continuity indoors and out / Continuité conceptuelle à l'intérieur et à l'extérieur / Entwurfskontinuität im innen-und Aussenbereich

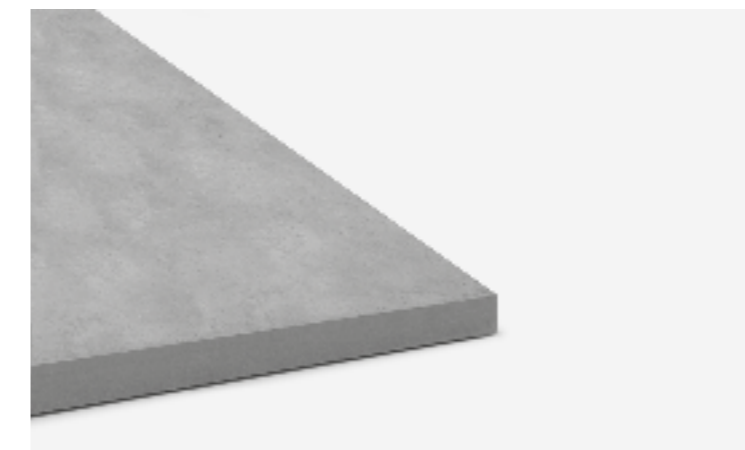

INDOOR



Soluzioni contemporanee per l'interior design
 Contemporary solutions for interior design.
 Solutions contemporaines pour le design intérieur.
 Zeitgemäße Lösungen für das Interior Design.



OUTDOOR



Versatilità e prestazioni per la progettazione in esterna
 Versatility and performance for outdoor design.
 Polyvalence et performance pour l'aménagement extérieur.
 Vielseitigkeit und Leistungen für Outdoor-Design.

SISTEMI DI POSA

Laying systems / Systemes de pose / Verlegearten

Posa su erba
 Laying on grass
 Pose sur l'herbe
 Verlegung auf Wiese



Posa su sabbia
 Laying on sand
 Pose sur sable
 Verlegung auf Sand



Posa sopraelevata
 Raised laying
 Pose surélevée
 Verlegung auf Stelzlägern



Posa su ghiaia
 Laying on gravel
 Pose sur gravier
 Verlegung auf Kies



Posa tradizionale
 Standard laying
 Pose traditionnelle
 Herkömmliche Verlegung

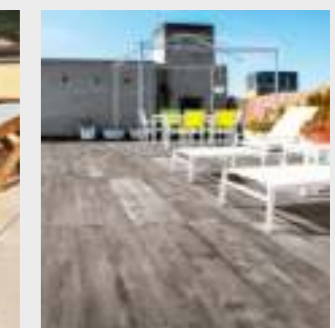

Spessore . Thickness . Epaisseur . Stärke - 10 mm

Gres porcellanato colorato in massa. Full-body coloured porcelain stoneware. Grès cérame coloré dans la masse. In der Masse gefärbtes Feinsteinzeug.

INDOOR

TABELLA RIEPILOGATIVA
Summary table
Tableau récapitulatif
Zusammenfassenden Tabelle

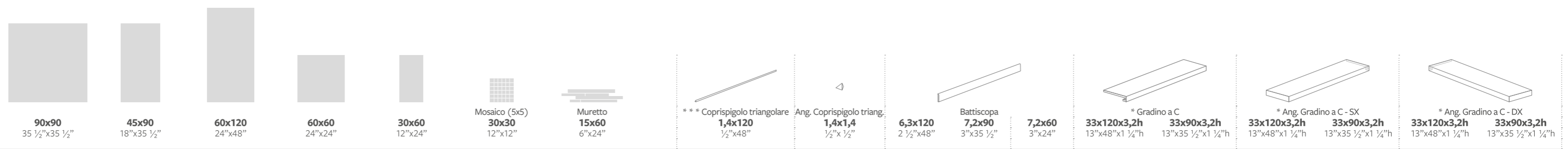

SPESSORE - THICKNESS - EPAISSEUR - STÄRKE			10 mm	10 mm	10 mm	10 mm	10 mm	10 mm	10 mm	10 mm	10 mm	10 mm	10 mm	10 mm	10 mm	10 mm	10 mm	10 mm	10 mm				
	ELVA	<input type="checkbox"/> Nat. Ret.	117072	117084	117077	117075	117112	117174	117184			117274	117275	117194	117204	117199	117214	117224	117234	117244	117254	117264	
	RIVOLI	<input type="checkbox"/> Nat. Ret.	117013	117083	117049	117038	117111	117173	117183			117273	117276	117193	117203	117198	117213	117223	117233	117243	117253	117263	
	OSTANA	<input type="checkbox"/> Nat. Ret.	117015	117082	117051	117040	117110	117172	117182			117272	117277	117192	117202	117197	117212	117222	117232	117242	117252	117262	
	CHIANALE	<input type="checkbox"/> Nat. Ret.	117020	117080	117056	117043	117108	117170	117180			117270	117278	117190	117200	117195	117210	117220	117230	117240	117250	117260	
	MURAZZANO	<input type="checkbox"/> Nat. Ret.	117017	117081	117054	117041	117109	117171	117181			117271	117279	117191	117201	117196	117211	117221	117231	117241	117251	117261	
MQ x pezzo - Sqm x pcs																							
Kg x pezzo - Kg x pcs																							
			Pallet	Pallet	Pallet	Pallet	Pallet	Pallet	Pallet			Pallet	Pallet	Pallet	Pallet	Pallet	Pallet	Pallet	Pallet	Pallet	Pallet	Pallet	
			94x120	94x120	80x120	80x120	80x120	80x120	80x120			80x120	80x120	80x120	80x120	80x120	80x120	80x120	80x120	80x120	80x120	80x120	
		N°																					
		m²																					
		** Kg																					
		x	2	3	2	3	6	11	3			6	9	8	14	2	2	1	1	1	1		
		m² x	1,62	1,22	1,44	1,08	1,08	0,99	0,27														
		Kg x	37	27	32	24,4	24,4	20	6			2	13	12	14,5	23	16,5	11,5	8,25	11,5	8,25		
		x	30	30	30	40	40																
		m² x	51,84	36,6	43,2	43,2	43,2																
		** Kg x	1130	830	980	1000	1000																
		h x	105	60	76	76	76																
	Imballo (tara) - Packaging (tare)		(20)	(20)	(20)	(20)	(20)	(20)	(20)			(20)	(20)	(20)	(20)	(20)	(20)	(20)	(20)	(20)	(20)	(20)	

I pesi riportati in tabella sono indicativi e potrebbero essere soggetti a leggere variazioni.
The weights stated in the chart may undergo slight changes for production reasons.
Les poids indiqués dans le tableau peuvent subir de légères variations pour des raisons de production.
Die in der Tabelle angegebenen Gewichte können aus Produktionsgründen geringfügigen Abweichungen unterliegen.

Non si garantisce l'abbinabilità tra fondi di spessori diversi e tra fondo e pezzo speciale.
It is not guaranteed that background tiles with different thicknesses can be used together, nor is it guaranteed for background tiles and trims.
Nous ne garantissons pas la possibilité de combiner des carrelages de sol de différentes épaisseurs et un carrelage de sol avec une pièce spéciale.
Die Kombinierbarkeit von Fliesen unterschiedlicher Stärke sowie zwischen Fliese und Formteil kann nicht garantiert werden.

* A disposizione solo su richiesta. Tempi di consegna 30 gg.
Available upon request only. Delivery terms: 30 days.
Disponibile seulement sur requête. Délais de livraison: 30 jours.
Verfügbar auf Anfrage. Lieferzeit: 30 Tage.

** Il peso è comprensivo dell'imballo.
The total weight includes the packaging.
Le poids comprend aussi l'emballage.
Das Gesamtgewicht enthält auch die Verpackung.

*** Vendita a scatola completa.
Full box sale.
Vente à la boîte complète.
Volle Kartons.

Naturale e rettificato.
Natural and rectified.
Naturél et rectifié.
Natur Oberfläche und kalibriert.

Spessore . Thickness . Epaisseur . Stärke - 10 mm R11 / 20 mm R11 / 30 mm R11

Gres porcellanato colorato in massa. Full-body coloured porcelain stoneware. Grès cérame coloré dans la masse. In der Masse gefärbtes Feinsteinzeug.

OUTDOOR

TABELLA RIEPILOGATIVA
 Summary table
 Tableau récapitulatif
 Zusammenfassenden Tabelle

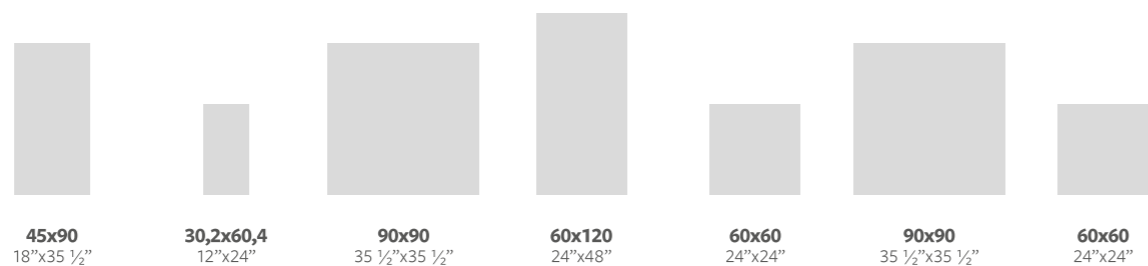

SPESSORE - THICKNESS - EPAISSEUR - STÄRKE		10 mm	10 mm	20 mm	20 mm	20 mm	30 mm	30 mm	10 mm	9,5 mm
	□ Nat. Ret.	117094		117070	117076	117073	117071	117074		
	■ Nat. Nat.		117103						117133	117142
	□ Nat. Ret.	117093		117001	117045	117025	117005	117029		
	■ Nat. Nat.		117102						117132	117141
	□ Nat. Ret.	117092		117002	117046	117026	117006	117030		
	■ Nat. Nat.		117101						117131	117140
	□ Nat. Ret.	117090		117004	117048	117028	117008	117032		
	■ Nat. Nat.		117099						117129	117138
	□ Nat. Ret.	117091		117003	117047	117027	117007	117031		
	■ Nat. Nat.		117100						117130	117139
N° m² Kg x m² x Kg x x m² x ** Kg x h x Imballo (tara) - Packaging (tare)										
	Pallet	Pallet	Pallet	Pallet	Pallet	Pallet	Pallet	Pallet	Pallet	Pallet
	94x120	80x120	94x94	80x120	80x120	95x95	65x120	80x120	80x120	

○ Nuova palletizzazione disponibile ad esaurimento dello stock esistente.
 New pallet configuration once current stock fully exhausted.
 Nouvelle palettisation disponible jusqu'à épuisement du stock existant.
 Neue Palettierung verfügbar solange der Vorrat reicht.

* A disposizione solo su richiesta. Tempi di consegna 30 gg.
 Available upon request only. Delivery terms: 30 days.
 Disponible seulement sur requête. Délais de livraison: 30 jours.
 Verfügbar auf Anfrage. Lieferzeit: 30 Tage.

** Il peso è comprensivo dell'imballo.
 The total weight includes the packaging.
 Le poids comprend aussi l'emballage.
 Das Gesamtgewicht enthält auch die Verpackung.

I pesi riportati in tabella sono indicativi e potrebbero essere soggetti a leggere variazioni.
 The weights stated in the chart may undergo slight changes for production reasons.
 Les poids indiqués dans le tableau peuvent subir de légères variations pour des raisons de production.
 Die in der Tabelle angegebenen Gewichte können aus Produktionsgründen geringfügigen Abweichungen unterliegen.

Non si garantisce l'abbinabilità tra fondi di spessori diversi e tra fondo e pezzo speciale.
 It is not guaranteed that background tiles with different thicknesses can be used together, nor is it guaranteed for background tiles and trims.
 Nous ne garantissons pas la possibilité de combiner des carrelages de sol de différentes épaisseurs et un carrelage de sol avec une pièce spéciale.
 Die Kombinierbarkeit von Fliesen unterschiedlicher Stärke sowie zwischen Fliese und Formteil kann nicht garantiert werden.

□ Naturale e rettificato.
 Natural and rectified.
 Naturel et rectifié.
 Natur Oberfläche und kalibriert.

■ Naturale e naturale.
 Natural and natural.
 Naturel et naturel.
 Natur natur.

△ Monolitico
 Monolithic step
 Monolitico
 Monolitische Stufenplatte

Spessore . Thickness . Epaisseur . Stärke - 20 mm R11

Gres porcellanato colorato in massa. Full-body coloured porcelain stoneware. Grès cérame coloré dans la masse. In der Masse gefärbtes Feinsteinzeug.

Pezzi speciali per esterno

Special pieces for outdoor - Pièces spéciales pour extérieur - Formteile für Aussenbereich

	* Gradone <input type="checkbox"/> Nat. Ret.			* Ang. Gradone - SX <input type="checkbox"/> Nat. Ret.			* Ang. Gradone - DX <input type="checkbox"/> Nat. Ret.		
	30x120 12"x48"	30x90 12"x35 1/2"	30x60 12"x24"	30x120 12"x48"	30x90 12"x35 1/2"	30x60 12"x24"	30x120 12"x48"	30x90 12"x35 1/2"	30x60 12"x24"
SPESSORE - THICKNESS - EPAISSEUR - STÄRKE	20 mm	20 mm	20 mm	20 mm	20 mm	20 mm	20 mm	20 mm	20 mm

	* Gradone grip <input type="checkbox"/> Nat. Ret.			* Ang. Gradone grip - SX <input type="checkbox"/> Nat. Ret.			* Ang. Gradone grip - DX <input type="checkbox"/> Nat. Ret.		
	30x120 12"x48"	30x90 12"x35 1/2"	30x60 12"x24"	30x120 12"x48"	30x90 12"x35 1/2"	30x60 12"x24"	30x120 12"x48"	30x90 12"x35 1/2"	30x60 12"x24"
SPESSORE - THICKNESS - EPAISSEUR - STÄRKE	20 mm	20 mm	20 mm	20 mm	20 mm	20 mm	20 mm	20 mm	20 mm

	* Elemento a L <input type="checkbox"/> Nat. Ret.			* Elemento a L SX <input type="checkbox"/> Nat. Ret.			* Elemento a L DX <input type="checkbox"/> Nat. Ret.		
	33x120x4h 13"x48"x1 1/2"h	33x90x4h 13"x35 1/2"x1 1/2"h	33x60x4h 13"x24"x1 1/2"h	33x120x4h 13"x48"x1 1/2"h	33x90x4h 13"x35 1/2"x1 1/2"h	33x60x4h 13"x24"x1 1/2"h	33x120x4h 13"x48"x1 1/2"h	33x90x4h 13"x35 1/2"x1 1/2"h	33x60x4h 13"x24"x1 1/2"h
SPESSORE - THICKNESS - EPAISSEUR - STÄRKE	20 mm	20 mm	20 mm	20 mm	20 mm	20 mm	20 mm	20 mm	20 mm

	*** piedino regolabile 25-30	*** piedino regolabile 30-37	*** piedino regolabile 37-50	*** piedino regolabile 50-75	*** piedino regolabile 75-125	*** piedino regolabile 125-225	*** prolunga piedini h 100 mm	chiave di regolazione
	600101	600102	600103	600104	600105	600106	600107	600108
	20	20	20	20	20	20	20	1

* A disposizione solo su richiesta. Tempi di consegna 30 gg.
Available upon request only. Delivery terms: 30 days.
Disponible seulement sur requête. Délais de livraison: 30 jours.
Verfügbar auf Anfrage. Lieferzeit: 30 Tage.

*** Vendita a scatola completa.
Full box sale.
Vente à la boîte complète.
Volle Kartons.

Naturale e rettificato.
Natural and rectified.
Naturel et rectifié.
Natur Oberfläche und kalibriert.

Costa retta.
Straight edge.
Bord droit.
Gerade Kante.

Costa tоро.
Bullnose edge.
Bord boudin.
Abgerundete Kante.

Per le condizioni generali di vendita e le caratteristiche tecniche consultare www.tagina.it
General terms and Sales conditions and Technical features are available on our website www.tagina.it
Les Conditions général de vente et les Caractéristiques techniques sont disponibles sur le site web www.tagina.it
Allgemeine Verkaufsbedingungen und technische Eigenschaften sind auf unsere Website verfügbar: www.tagina.it

Pezzi speciali per piscina

Special pieces for swimming pool - Pièces spéciales pour piscine - Formteile für Schwimmbad

	* Gradone bordo piscina <input type="checkbox"/> Nat. Ret.			* Ang. Gradone bordo piscina - SX <input type="checkbox"/> Nat. Ret.			* Ang. Gradone bordo piscina - DX <input type="checkbox"/> Nat. Ret.		
	30x120 12"x48"	30x90 12"x35 1/2"	30x60 12"x24"	30x120 12"x48"	30x90 12"x35 1/2"	30x60 12"x24"	30x120 12"x48"	30x90 12"x35 1/2"	30x60 12"x24"
SPESSORE - THICKNESS - EPAISSEUR - STÄRKE	20 mm	20 mm	20 mm	20 mm	20 mm	20 mm	20 mm	20 mm	20 mm

	* Gradone grip bordo piscina <input type="checkbox"/> Nat. Ret.			* Ang. Gradone grip bordo piscina - SX <input type="checkbox"/> Nat. Ret.			* Ang. Gradone grip bordo piscina - DX <input type="checkbox"/> Nat. Ret.		
	30x120 12"x48"	30x90 12"x35 1/2"	30x60 12"x24"	30x120 12"x48"	30x90 12"x35 1/2"	30x60 12"x24"	30x120 12"x48"	30x90 12"x35 1/2"	30x60 12"x24"
SPESSORE - THICKNESS - EPAISSEUR - STÄRKE	20 mm	20 mm	20 mm	20 mm	20 mm	20 mm	20 mm	20 mm	20 mm

	* Gradone svasato bordo piscina <input type="checkbox"/> Nat. Ret.			* Ang. Gradone svasato bordo piscina - SX <input type="checkbox"/> Nat. Ret.			* Ang. Gradone svasato bordo piscina - DX <input type="checkbox"/> Nat. Ret.		
	30x120 12"x48"	30x90 12"x35 1/2"	30x60 12"x24"	30x120 12"x48"	30x90 12"x35 1/2"	30x60 12"x24"	30x120 12"x48"	30x90 12"x35 1/2"	30x60 12"x24"
SPESSORE - THICKNESS - EPAISSEUR - STÄRKE	20 mm	20 mm	20 mm	20 mm	20 mm	20 mm	20 mm	20 mm	20 mm

	* Griglia <input type="checkbox"/> Nat. Ret.	* Griglia SX <input type="checkbox"/> Nat. Ret.	* Griglia DX <input type="checkbox"/> Nat. Ret.
	20x60 8"x24"	20x60 8"x24"	20x60 8"x24"
SPESSORE - THICKNESS - EPAISSEUR - STÄRKE	20 mm	20 mm	20 mm

Per maggiori informazioni su imballi e codici articolo potete consultare il nostro ORGANIZER (anche da sito internet, nell'area "download").
Tagina S.p.A. reserves the right to change the product packaging, the patterns, colours and decorations shown in the pictures without any prior notice. These aspects, therefore should be considered for illustrative purposes only.
Pour plus d'informations sur les emballages et les codes articles, vous pouvez consulter notre ORGANIZER (également depuis le site, dans la zone "téléchargement").
Weitere Informationen zu Verpackungen und Artikelcodes finden Sie in unserem ORGANIZER (auch auf der Website, im Bereich "Download").

Tagina S.p.a. si riserva di modificare, senza alcun preavviso, il packaging dei prodotti, le grafiche, i colori e i decori riportati nelle immagini che sono pertanto da ritenersi indicative.
Tagina S.p.A. reserves the right to change the product packaging, the patterns, colours and decorations shown in the pictures without any prior notice. These aspects, therefore should be considered for illustrative purposes only.
Tagina S.p.A. se réserve le droit de modifier, sans préavis, l'emballage des produits, les graphismes, les couleurs et les décors représentés dans les images, fournies à titre indicatif.
Die Tagina S.p.A. behält sich vor, die Verpackung der Produkte, die in den Abbildungen gezeigten Grafiken, Farben und Dekors sowie ohne vorherige Ankündigung zu ändern.

PEZZI SPECIALI PER ESTERNO

Special pieces for outdoor
Pièces spéciales pour extérieur
Formteile für Aussenbereich

Elemento a L



Gradone grip

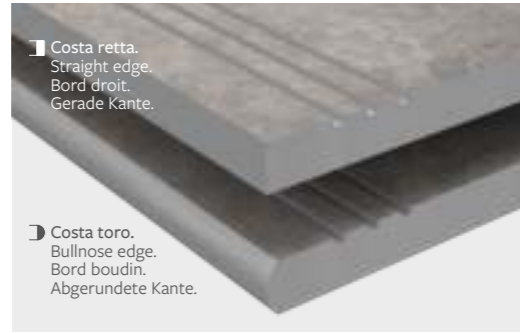

Gradone

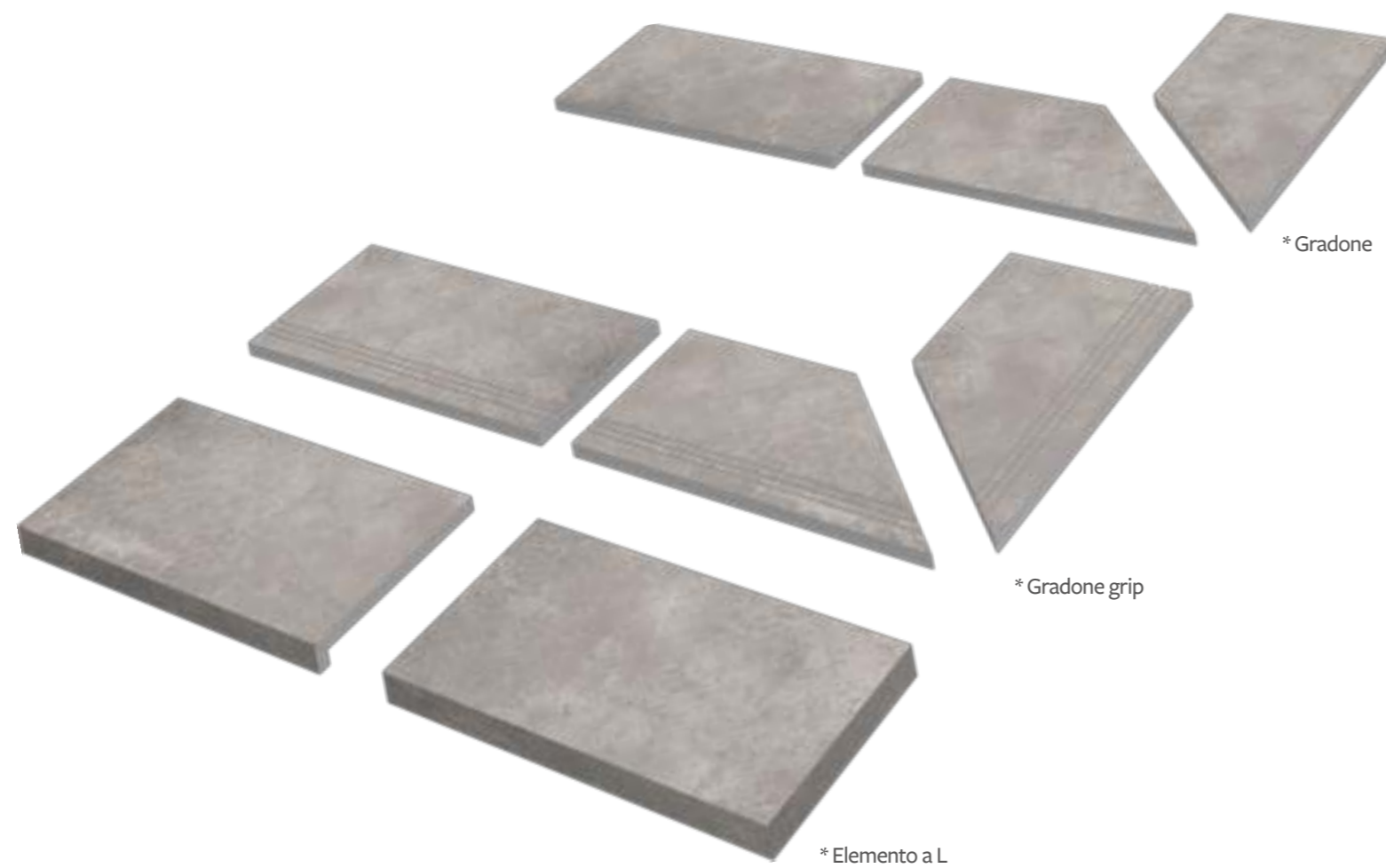

PEZZI SPECIALI PER PISCINA

Special pieces for swimming pool
Pièces spéciales pour piscine
Formteile für Schwimmbad

Gradone svasato bordo piscina

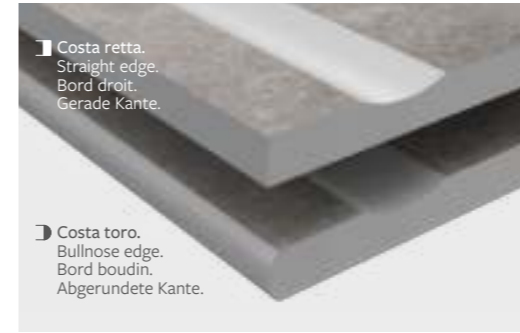

Gradone grip bordo piscina

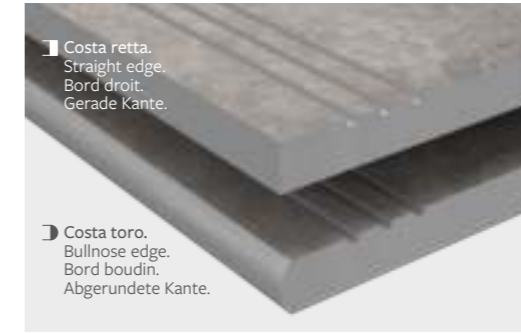

Gradone bordo piscina

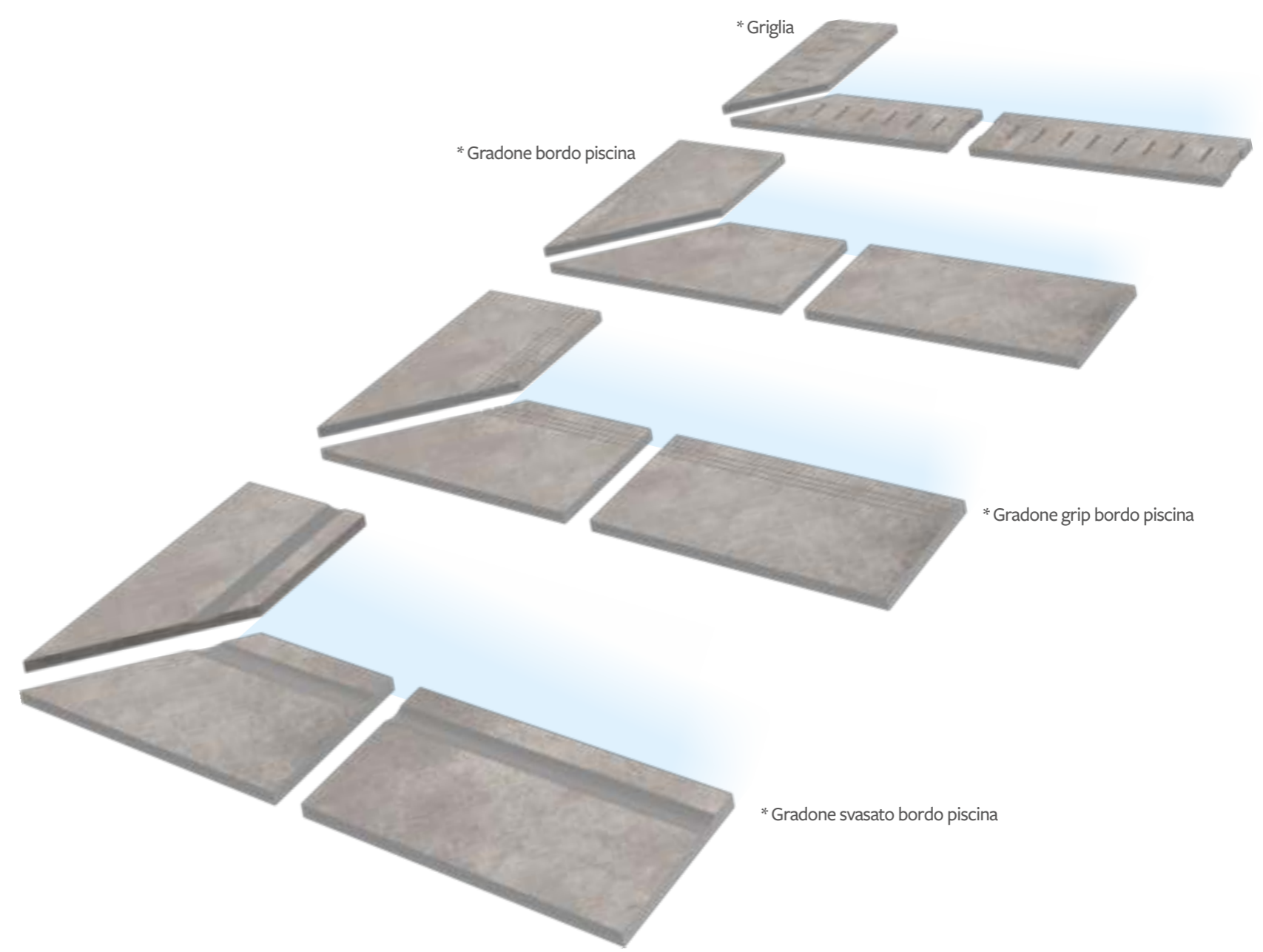

* I tempi di consegna di tutti i pezzi speciali mostrati in queste pagine sono di 30 giorni dalla data dell'ordine.
Delivery time for all the special pieces shown on these pages are generally 30 days from order date.
La livraison de toutes les pièces spéciales présentés dans les pages du catalogue sont disponible 30 jours à compter de la date de commande.
Der Liefertermin fuer die Spezialteile, die in dieser Seite aufgefuehrt sind, belaeuft sich auf 30 Tage nach Auftragseingang.

Pezzi speciali: massima cura in ogni dettaglio

Special pieces: the utmost care in every detail.
Pièces spéciales : le soin maximal dans le moindre détail.
Formteile: maximale Sorgfalt in jedem Detail.

IL FASCINO TRADIZIONALE DEL GRADINO A "C"

The traditional appeal of the "C" step.
Le charme traditionnel de l'étape « C »
Der traditionelle Charme der „C“-Stufe.

Tagina pone attenzione a tutte le componenti architettoniche degli spazi da abitare. Ai gradini sono dedicati pezzi speciali appositamente progettati per ottenere il massimo risultato estetico. La gamma comprende un elemento "gradino a C" al quale si possono affiancare gli elementi che completano gli angoli sinistro e

Tagina takes great care over all the architectural elements of the living spaces. Special pieces are used for the stairs, specially designed to obtain the maximum aesthetic result. The range includes a "C-step" element which can be combined with the elements that complete the left and right corners.

Tagina prête attention à toutes les composantes architecturales des espaces de vie. Les étapes sont dédiées à des pièces spéciales spécialement conçues pour obtenir un résultat esthétique maximal. La gamme comprend un élément « marche en C » auquel vous pouvez assortir les autres éléments qui complètent les angles gauche et droit.

Tagina achtet auf alle architektonischen Komponenten der Wohnräume. Den Stufen sind Spezialteile gewidmet, um ein optimales ästhetisches Ergebnis zu erzielen. Das Sortiment umfasst ein „C-Stufen-Element“, das durch Elemente zur Vervollständigung der linken und rechten Ecke ergänzt werden kann.

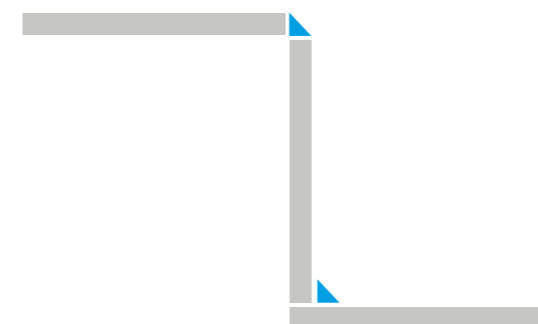
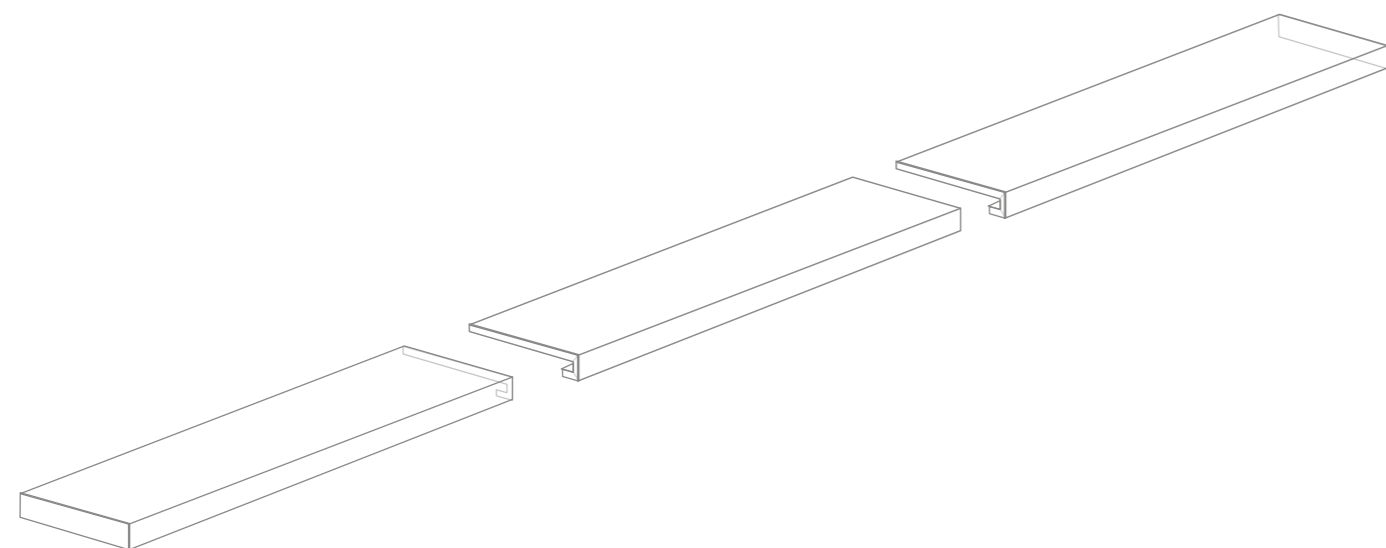

IL "COPRISPIGOLO TRIANGOLARE"

The "triangular edge cover".
Le « cache-arête triangulaire »
„Dreieckiger Kantenschutz“

La gamma della collezione "Pietra Regale" include l'elemento "Coprispigolo triangolare" e "Angolo Coprispigolo triangolare". Consente di risolvere con eleganza e semplicità problematiche legate alla congiunzione delle lastre in presenza di spigoli e angoli. È possibile adottare questa soluzione sia a rivestimento che a pavimento ad esempio per realizzare gradini o per comporre volumi geometrici.

The range of the "Pietra Regale" collection includes the "Triangular edge cover and Triangular corner edge cover" element. It allows problems encountered to be solved elegantly and simply when joining slabs where there are edges and corners. It is possible to adopt this solution both for cladding and flooring, e.g. to create steps or compose geometric volumes.

La gamme de la collection « Pietra Regale » comprend l'élément «Cache-arête Triangulaire et Angle Cache-arête Triangulaire». Il permet de résoudre avec élégance et simplicité les problèmes liés à l'assemblage des dalles en présence de bords et de coins. Il est possible d'adopter cette solution aussi bien pour le revêtement que pour le dallage, par exemple pour créer des marches ou composer des volumes géométriques.

Das Sortiment der Kollektion „Pietra Regale“ umfasst das Element „Dreieckige Eckabdeckung und Winkel Dreieckige Eckabdeckung“. Es ermöglicht, mit Eleganz und Einfachheit alle Probleme zu lösen, die mit dem Zusammenfügen der Platten bei Vorhandensein von Kanten und Ecken zusammenhängen. Diese Lösung kann sowohl für Verkleidungen als auch für Böden verwendet werden, beispielsweise um Stufen oder geometrische Volumen zu schaffen.





Tagina S.p.A.
Via Emilia Ponente, 925
48014 Castel Bolognese (RA) - Italy
Tel. +39 0545 197 7303

tagina.it -  DAFIN GROUP



Follow us