

## Milk Receiver Assemblies

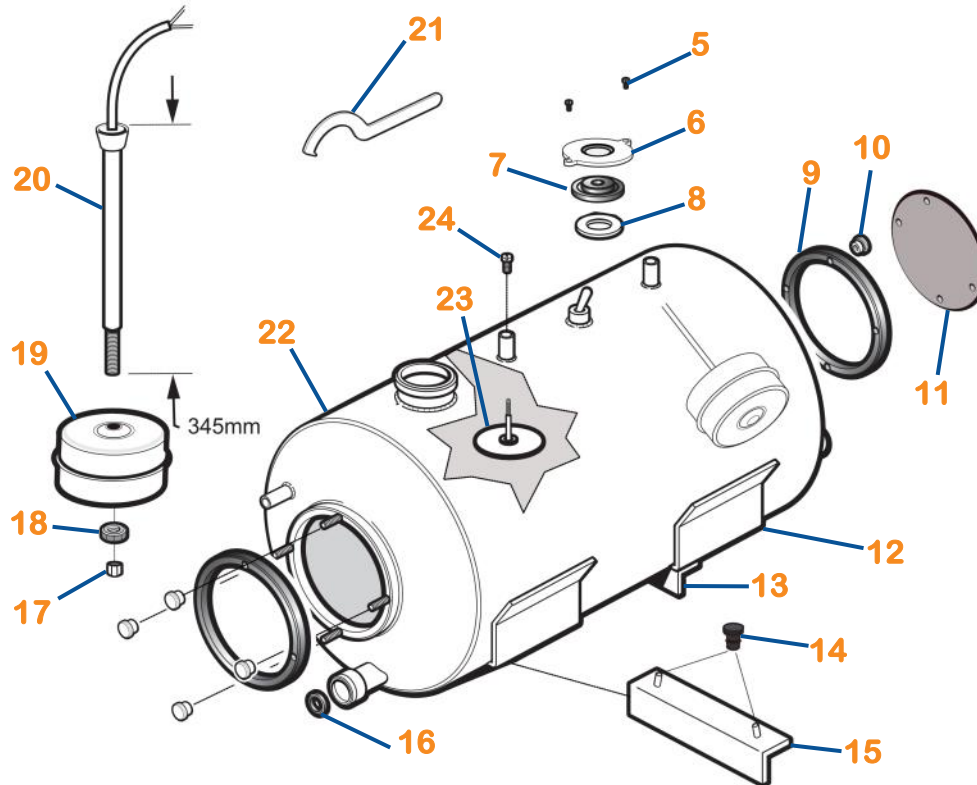
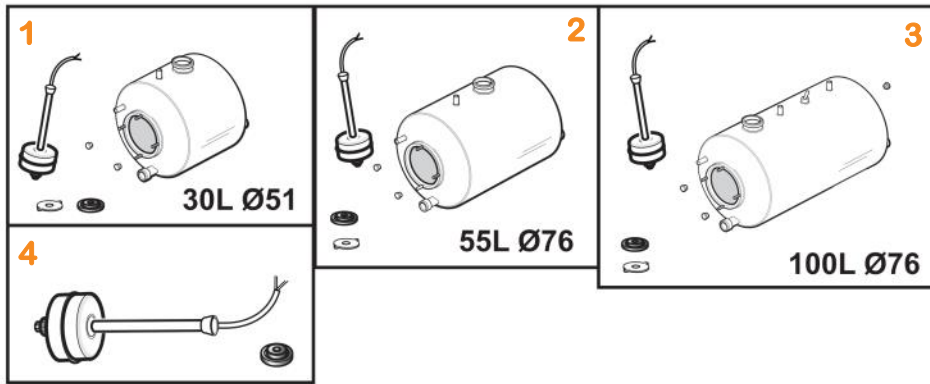

The 100 litre assembly is available with an additional milk pump which necessitates a second starter in a separate box, electronically linked to the control box.

Where two milk pumps are used an additional right handed stainless steel mounting plate is required

- 1 [614117](#) - 30 Litre Assembly
- 2 [614094](#) - 55 Litre Assembly
- 3 [100 Litre Receiver Assembly](#)
- 4 [614825](#) - Probe & Float pack
- 5 [300444](#) - M5 Screw
- 6 [613567](#) - M5 Clamping Plate
- 7 [612824](#) - Probe Gasket
- 8 [614381](#) - Rubber Ring
- 9 [613119](#) - Lid Gasket
- 10 [613998](#) - Knurled Nut
- 11 FOR LIDS & MILK LINE WASH SECTIONS PLEASE SEE SEPARATE DIAGRAMS
- 12 [614002](#) - Vessel Cradle
- 13 [614753](#) - Frame & Cradle
- 14 [607946](#) - Drain Nozzle
- 15 [614014](#) - Wall Support
- 16 [607755](#) - Step Seal 40mm
- 17 [607640](#) - M6 Domed Hex Nut
- 18 [607925](#) - M6 Plate Nut
- 19 [613509](#) - Receiver Float
- 20 [607803](#) - Receiver Probe
- 21 [613204](#) - Spanner 52-55mm
- 22 [614118](#) - 30 Litre Body
- 23 [303005](#) - Wash Dist. Trap
- 24 [300509](#) - M4 Wash Nut Cap

[614119](#) -  
*30 & 55l Litre Accessory Pack*

[614120](#) - *100 Litre Accessory Pack -1 Pump*

[614121](#) - *100 Litre Accessory Pack - 2 Pump*