

PRO-SERIES WALL CABINET

Bridging Wall (Door, Solid Top) - Fitting Guide

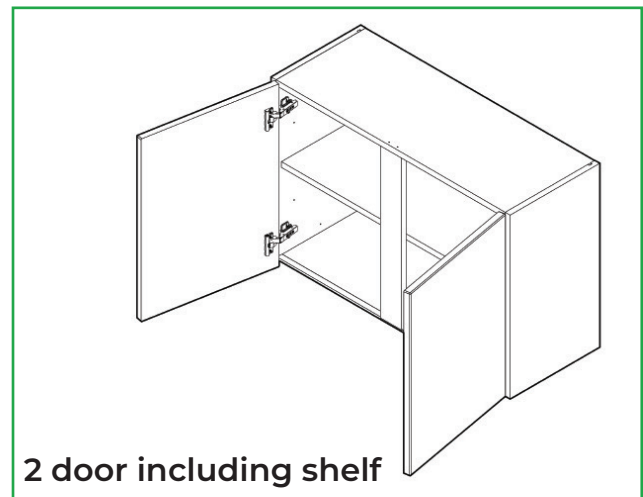

Cabinet Parts

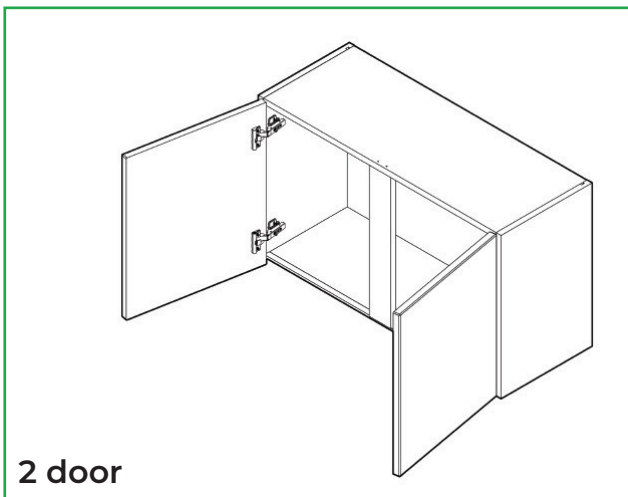
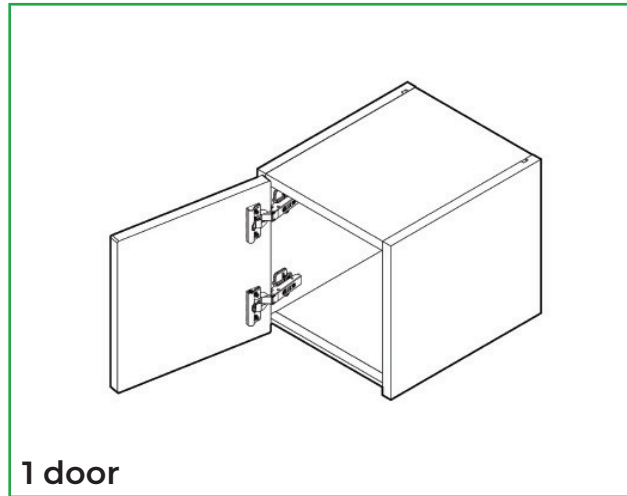
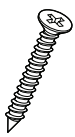

8x
1 1/4" Screws



12x
Cover Caps



5x
Door Buffers



4x
Shelf Supports
(If required)

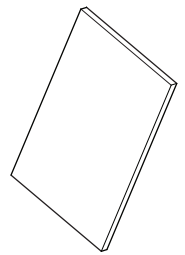

1x
Shelf
(If required)

Tools Required

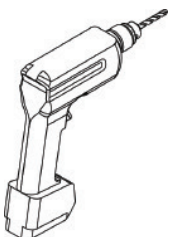

Drill



Stud Finder



Screwdriver

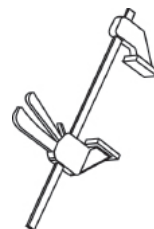

Clamp



Spirit Level

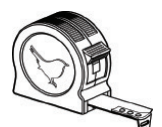

Tape Measure



Before installing any wall cabinets, ensure the wall construction is strong enough to support the weight of the fully loaded cabinet and that appropriate fixings are used.

If you are unsure, seek professional advice before proceeding.

Remember to take care when unpacking. Please keep your workspace clean, clear, and tidy when working. This will help keep all items safe from damage. Any waste cardboard or plastic should be flattened down and placed in the trash can.

A minimum of two people will be needed to lift the cabinet.

Removing the frontal/s

Before installing the cabinet, remove the frontal by pulling the release catch.

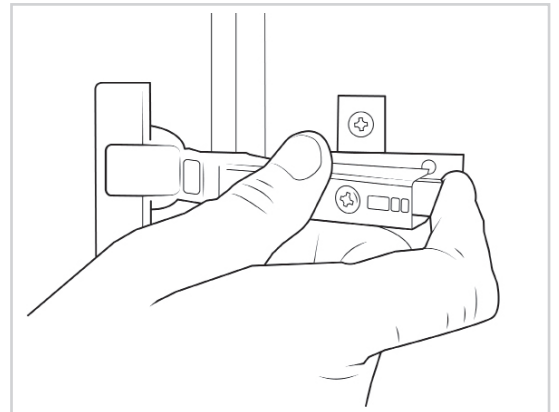

Removing the fittings

Remove all content so the cabinet is empty.

All fittings should be kept on a clean, level surface.

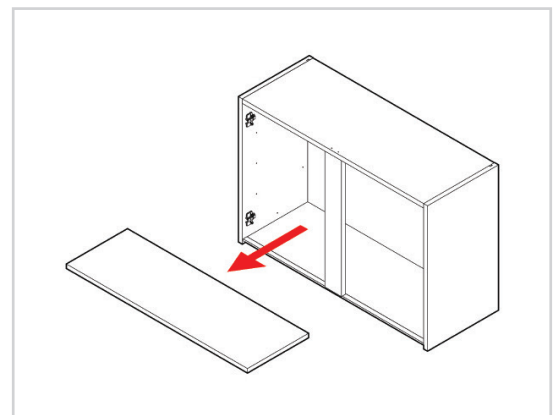

Locating the studs

Using a stud finder, locate the studs where the cabinet will be installed and mark the wall above and below where the cabinet will sit.

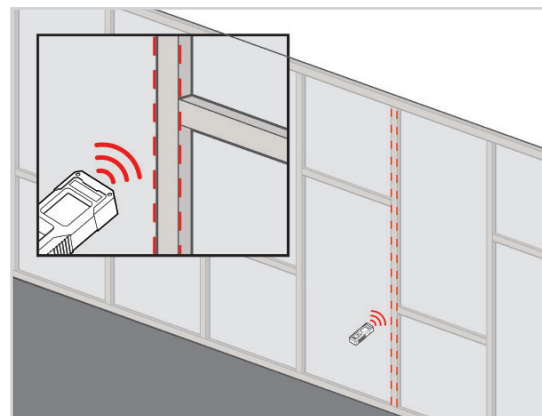

For help on determining the sort of wall you have, please refer to the “Room Preparation Guide.”

Checking if the cabinet is level

Before installing the cabinet, hold the cabinet against the wall and check that it is level in multiple places using a spirit level.

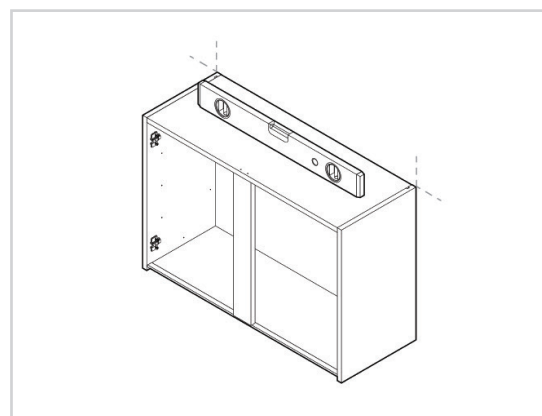

No screws or wall plugs are provided for attaching the cabinet to the wall. This is due to variations in wall construction.

Securing the cabinet

Secure the cabinet in **2** places along the top rail and in **2** places along the bottom rail, where the studs are located, using the appropriate fixings.

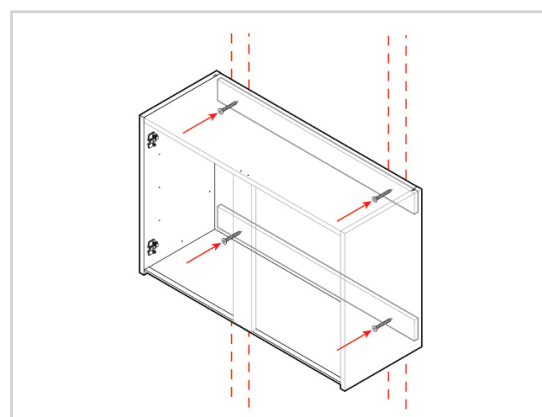

Attaching a second cabinet

To secure an additional cabinet, fix **2x** screws at the front of the cabinet, just behind the hinge plates, and **2x** screws at the rear of the cabinet at the top and bottom, using **1 1/4"** screws.

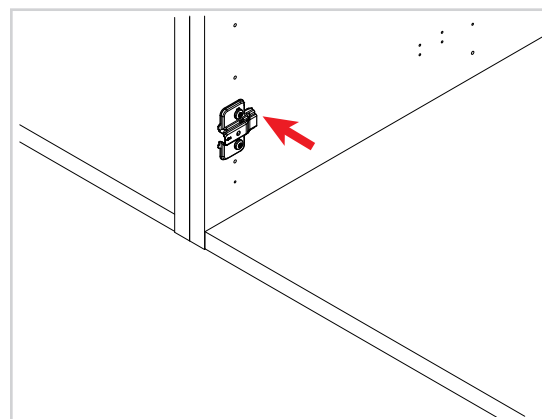

Placing the shelf into position (If required)

Position the shelf pegs into the pre-drilled holes.

Place the shelves into position so the pin of each shelf peg is inserted into the pre-drilled holes.

The shelves will touch the back panel when installed, if there is a gap between the back panel and shelf, then the shelf has been installed back to front and the shelf needs to be rotated.

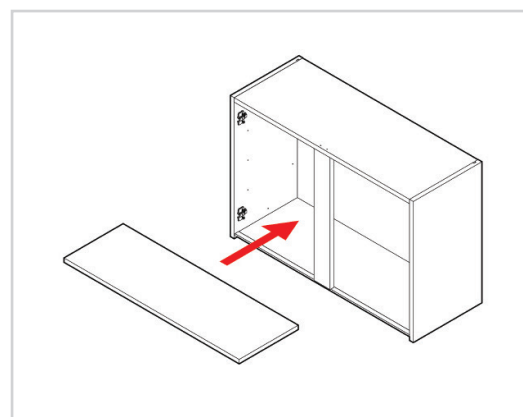

Attaching the frontal

The frontal should be re-attached to the cabinet by clipping the hinges onto the hinge plates. The bar of the hinge needs to be positioned into the hooks on the hinge plate. Then the rear of the hinge is pushed to the hinge plate until it clicks.

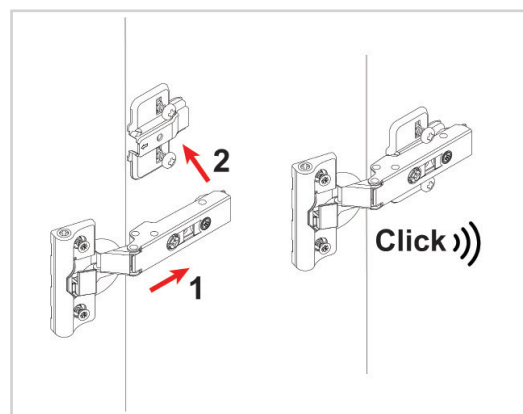

Adding the door buffers

Position the door buffers as illustrated in the images.

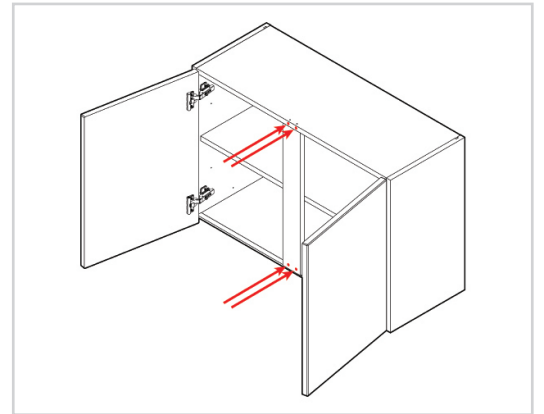
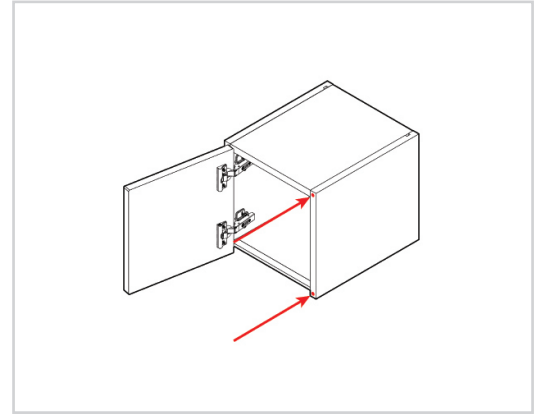

Cleaning the cabinet

Finally, the cabinet should be thoroughly cleaned to remove any debris that may have accumulated during the installation.

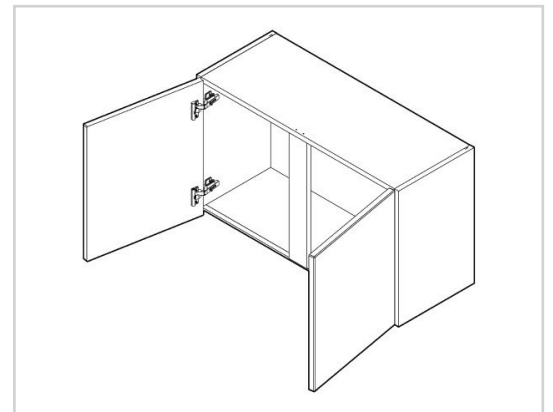

For door alignment please review the following installation guide:
[Door - Door Hinge Adjustment](#)