

# Base Cabinet

## Base (Door, Open Top, 4 Legs) - Fitting Guide

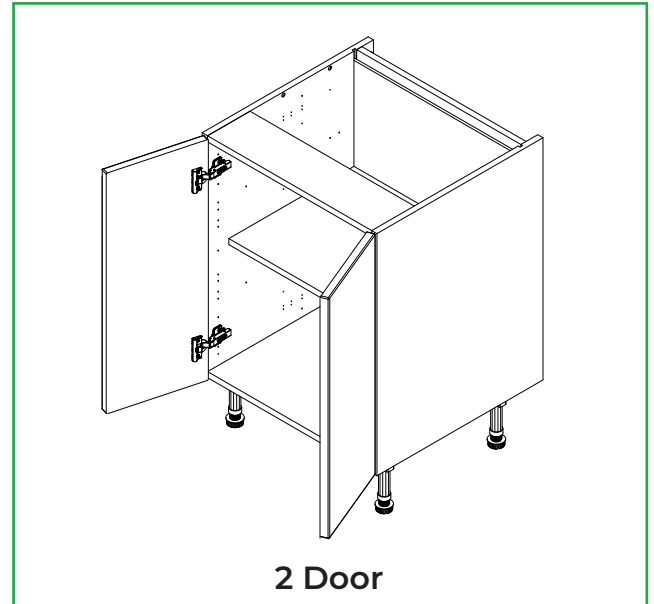

### Cabinet Parts

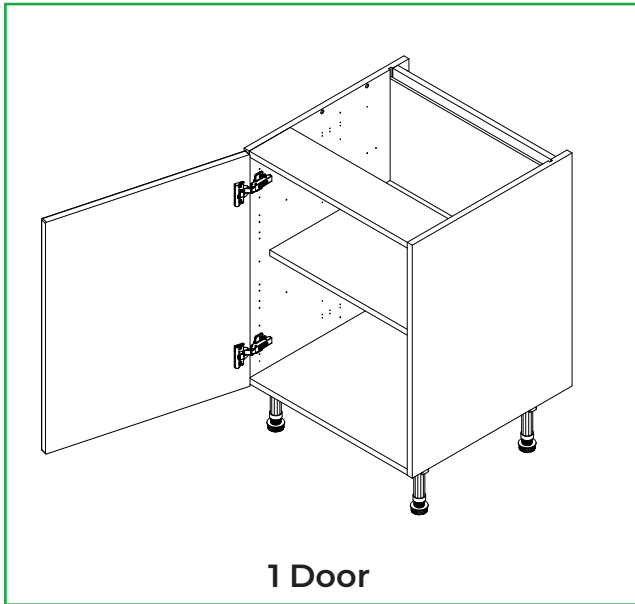
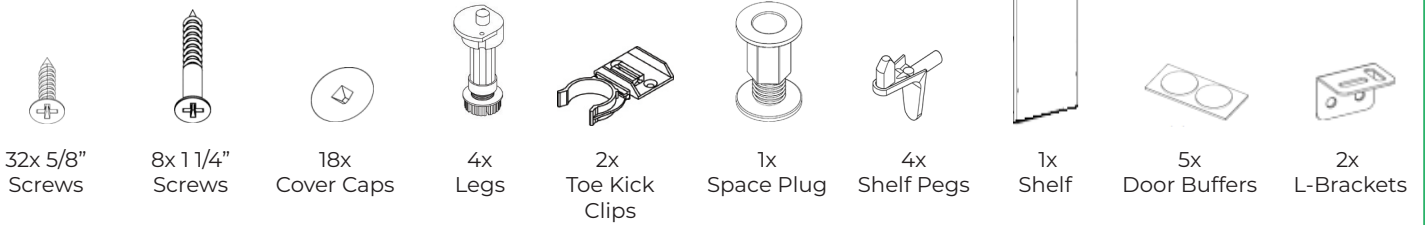

### Tools Required

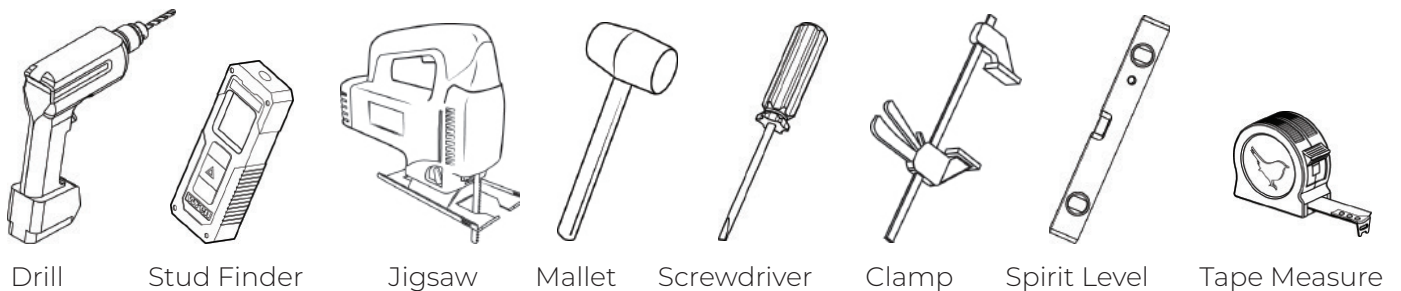

Remember to take care when unpacking. Please keep your workspace clean, clear, and tidy when working. This will help keep all items safe from damage. Any waste cardboard or plastic should be flattened down and placed in the trash can.

A minimum of two people will be needed to lift the cabinet.

### Remove the frontal

Before installing the cabinet, the frontal needs to be removed by pulling the release catch.

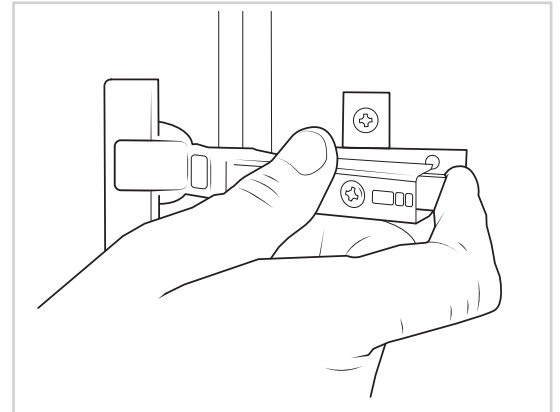

### Remove the fittings

All of the fittings need to be removed from the inside of the cabinet, so it is empty.

Make sure all of the fittings are kept on a clean and level surface.

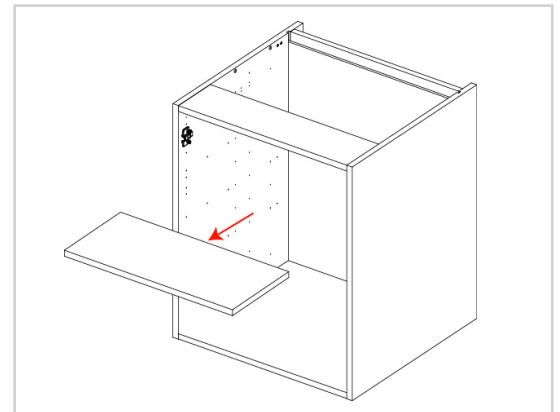

### Securing the legs

Secure each of the cabinet legs to the cabinet using **2x 5/8"** screws per leg.

Make sure the legs are positioned as seen in the image to support the end panel.

Set the leg height to **4 9/16"**. The leg height can be adjusted by turning the foot of the leg clockwise or anti-clockwise.

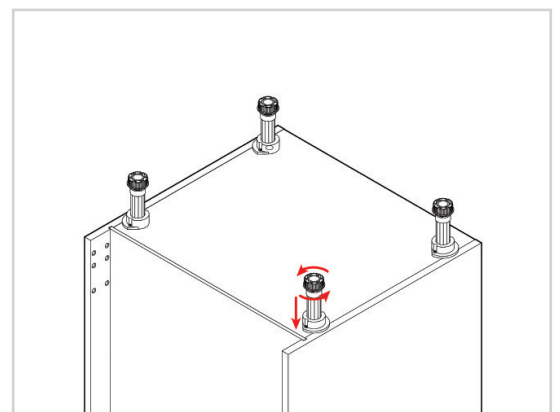

## Notching out the side panel (if required)

In order to allow for any horizontal pipework running behind the cabinet, some cabinets will require the back of the cabinet side to be notched out.

Create a notch for the horizontal pipes at the back of the end panels using a jigsaw.

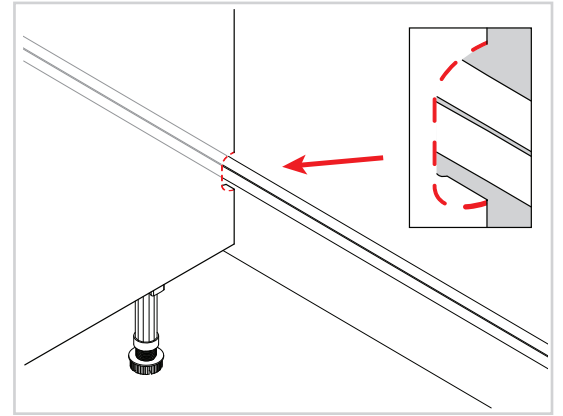

## Locating the stud

Using a stud finder, locate the studs where the cabinet will be installed and mark the wall where the cabinet will sit.

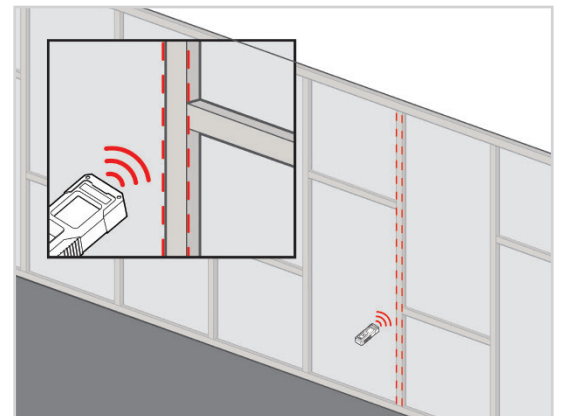

For help on determining the sort of wall you have, please refer to the “Room Preparation Guide.”

## Lifting the cabinet into place

When lifting the cabinet into place, do not tilt, as this can damage the legs.

Position the cabinet against the wall so that the stud is in the center of the cabinet.

Use a spirit level to ensure the cabinet is level from front to back, left to right, and diagonally.

Adjust the legs if required.

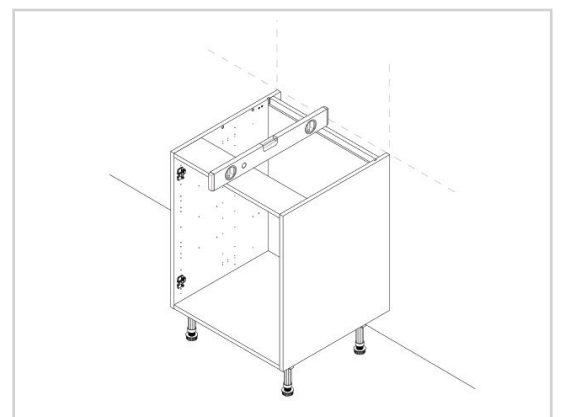

Screws and fixings for attaching the cabinet to the wall are not provided, as these vary depending on the wall material and construction. Check that the appropriate fixings for the wall construction are used.

### Drilling the pilot hole

Drill a pilot hole through the back rail in line with the wall studs, making sure to lightly mark the wall where the screw should be placed. The hole should be located, as per the diagram, close to the top of the cabinet.

Once complete, lift and move the cabinet away from the wall.

Drill a pilot hole at the marked position.

Lift and reposition the cabinet, ensuring it is level and in line with the wall marking.

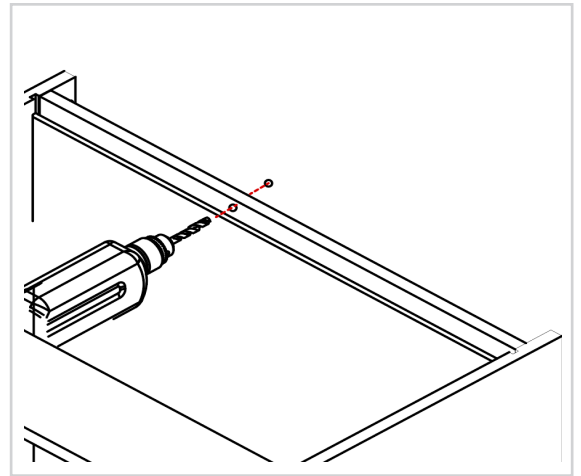

### Inserting the space plug

Position the space plug between the wall and the back of the cabinet, where the hole is located.

Unwind until the space plug touches both the back panel of the cabinet and the wall.

Insert the screws into the drilled hole and secure the cabinet to the wall.

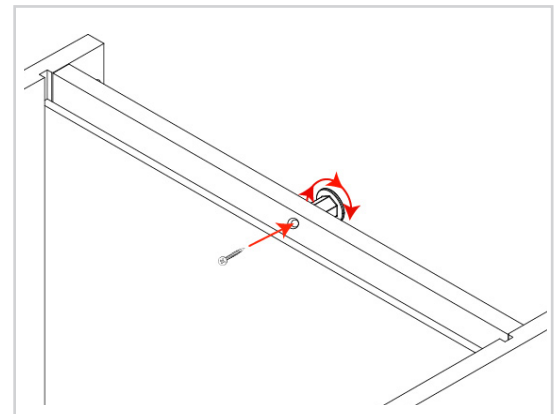

### Securing adjacent cabinets

Any adjacent cabinets need to be secured using the **1 1/4"** screws provided. Screw to the rear of both hinge plates and to the rear of the cabinet at the top and bottom.

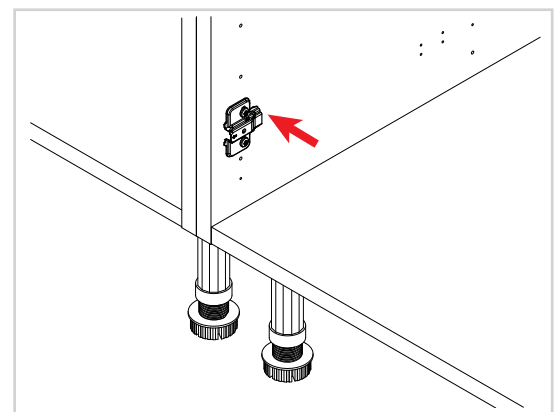

## Finding the shelf height

Find where the shelf will be installed (this is down to personal preference). Then insert the shelf pegs into the pre-drilled holes.

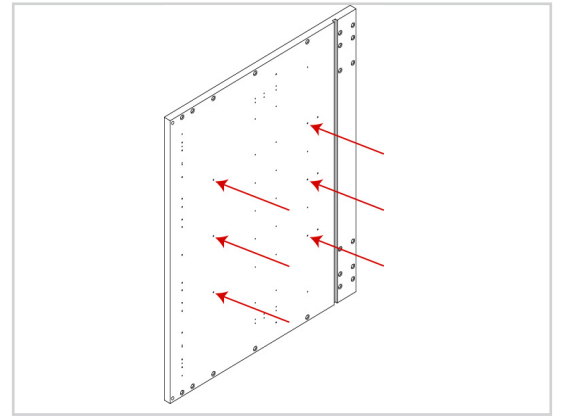

## Inserting the shelf into position

The shelf will touch the back of the cabinet when installed. If there is a gap between the back panel and the shelf, this means the shelf has been installed back to front and the shelf needs to be rotated.

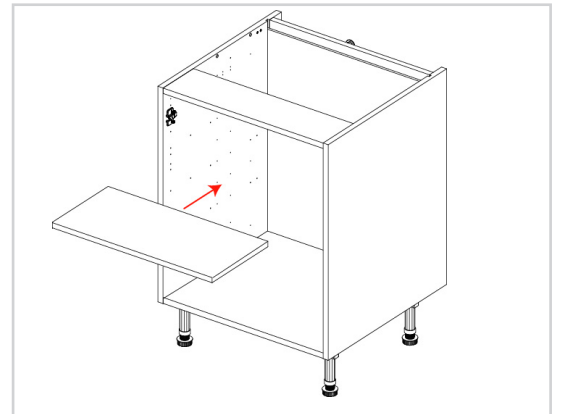

## Attaching the frontal

The frontal needs to be re-attached to the cabinet, position the hinge arm on the hooks on the hinge plate. Then push the rear of the hinge arm towards the hinge plate until it clicks.

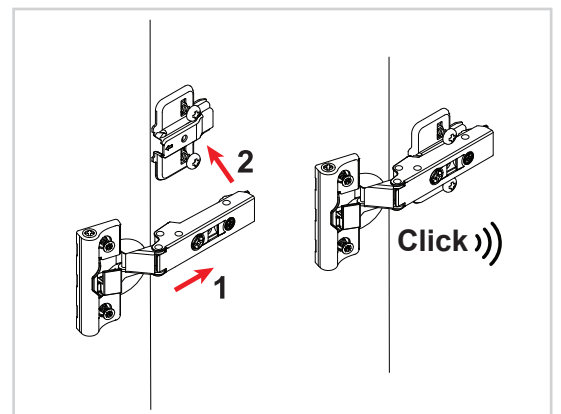

## Adding the door buffers

Position the door buffers on the cabinet, as seen in the images.

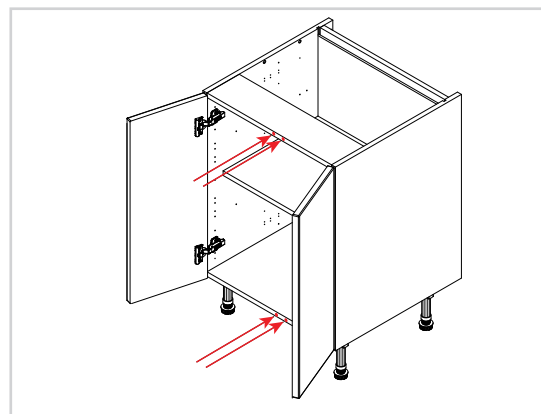
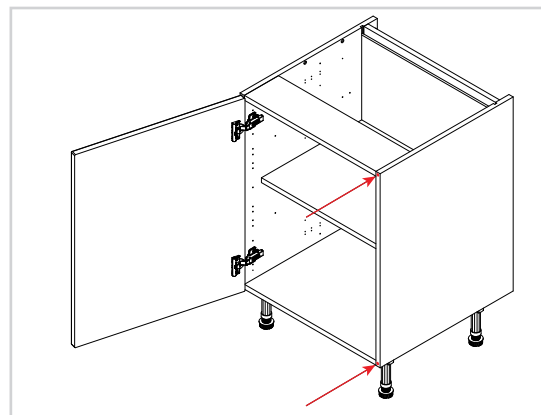

## Cleaning the cabinet

Finally, the cabinet should be thoroughly cleaned to remove any debris that may have accumulated during the installation.

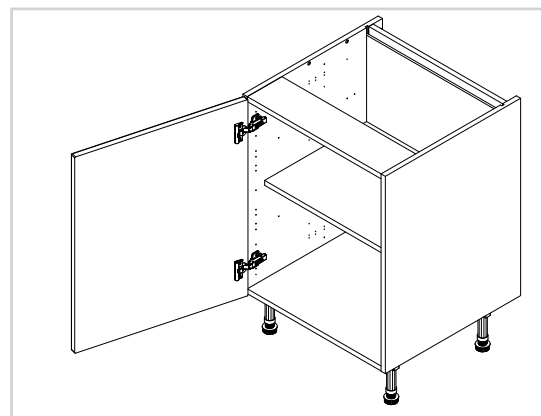

Store the toe kick clips and the remaining 5/8" screws.  
These will be used later when attaching the toe kick.

Store the L-brackets.  
These will be used later when installing the countertop (laminated or timber).

For door alignment please review the following installation guide:  
[Door - Door Hinge Adjustment.](#)