

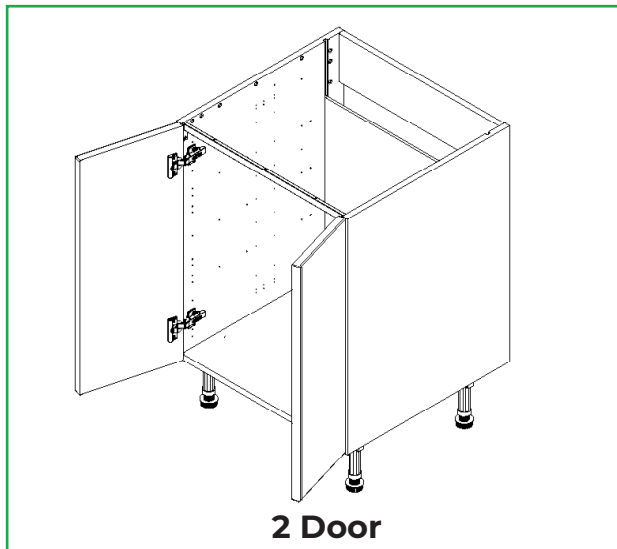

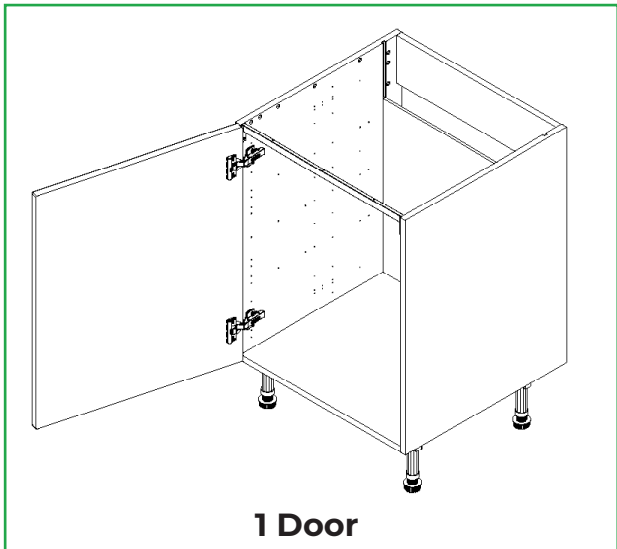







Base Cabinet

Cooktop Base (Door, Open Top, 4 Legs) -Fitting Guide

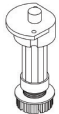

Cabinet Parts

 32x 5/8" Screws	 6x 1 1/4" Screws	 18x Cover Caps	 4x Shelf Pegs	 1x Shelf
 4x Legs	 2x Toe Kick Clips	 5x Door Buffers	 2x L-Brackets	

Tools Required

 Drill	 Stud Finder	 Jigsaw	 Mallet	 Screwdriver	 Clamp	 Spirit Level	 Tape Measure
---	--	---	---	--	---	---	---

Remember to take care when unpacking. Please keep your workspace clean, clear, and tidy when working. This will help keep all items safe from damage. Any waste cardboard or plastic should be flattened down and placed in the trash can.

A minimum of two people will be needed to lift the cabinet.

Removing the frontal

Before installing the cabinet, remove the frontal by pulling the release catch.

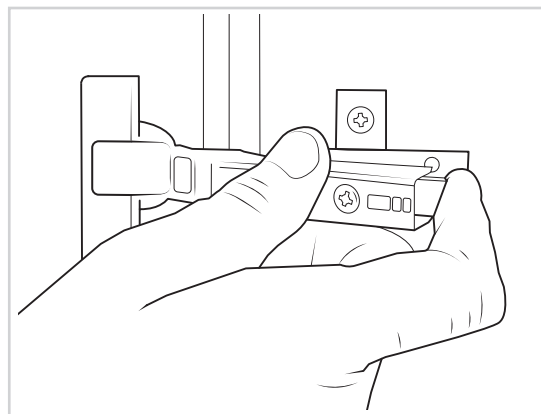

Removing the fittings

Remove all content so the cabinet is empty.

All fittings should be kept on a clean, level surface.

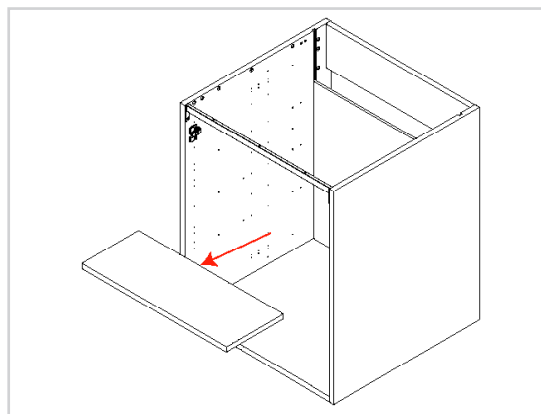

Securing the legs

Secure each of the cabinet legs to the cabinet using **2x 5/8"** screws per leg.

Make sure the legs are positioned as seen in the image to support the end panel.

Set the leg height to **4 9/16"**. The leg height can be adjusted by turning the foot of the leg clockwise or anti-clockwise.

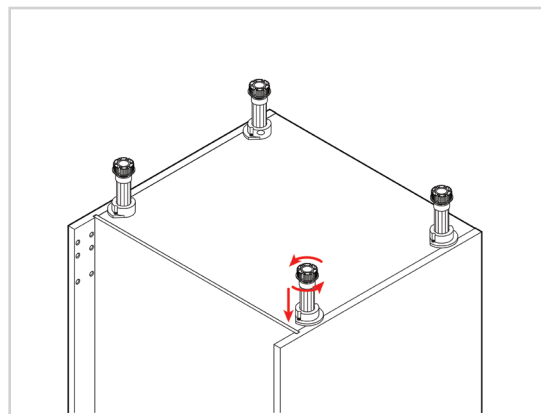

Lifting the cabinet into place

When lifting the cabinet into place, do **not** tilt, as this can damage the legs.

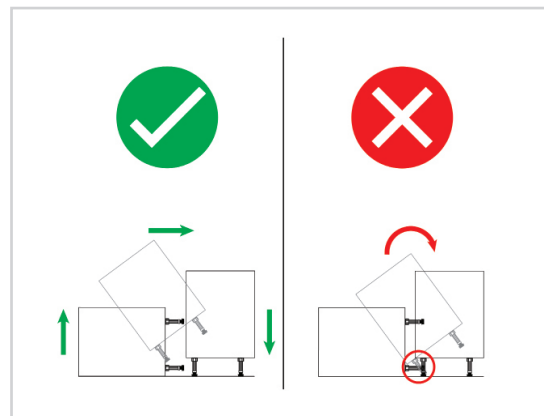

Locating the stud

Using a stud finder, locate the studs where the cabinet will be installed and mark the wall where the cabinet will sit.

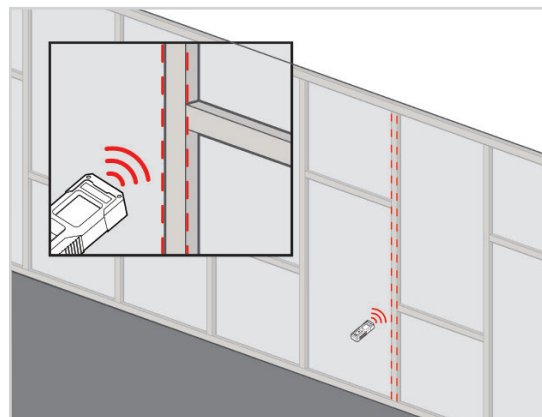

For help on determining the sort of wall you have, please refer to the “Room Preparation Guide.”

Notching out the end panels (when required)

In order to allow for any horizontal pipework running behind the cabinet, some cabinets will require the back of the cabinet's side to be notched out.

Create a notch for the horizontal pipes at the back of the end panels using a jigsaw.

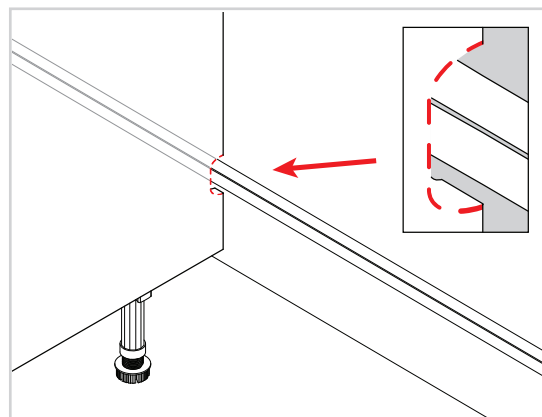

Sliding the cabinet into place

Slide the cabinet against the wall and align it with the wall markings and the services.

Use a spirit level to ensure the cabinet is level from front to back, left to right, and diagonally. Adjust the legs if required.

The leg height can be adjusted by turning the foot of the leg clockwise or anti-clockwise.

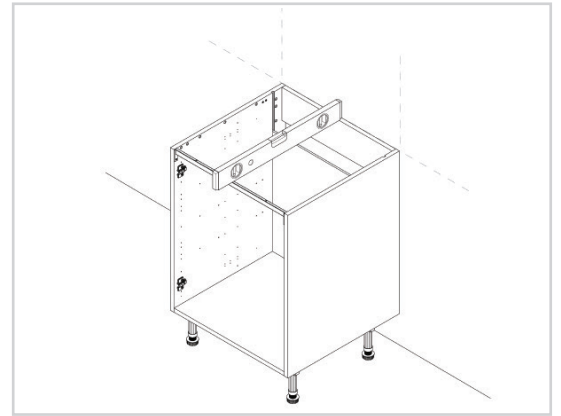

Before drilling into the wall, you **MUST** check for any hidden services or pipework within the walls.

Finding the center point

Find the center point measurement of the rear top rail and lightly mark this position.

Transfer the measurement onto the wall at the cabinet markings, which were drawn at the room preparation stage.

This will be the position of the wall fixing.

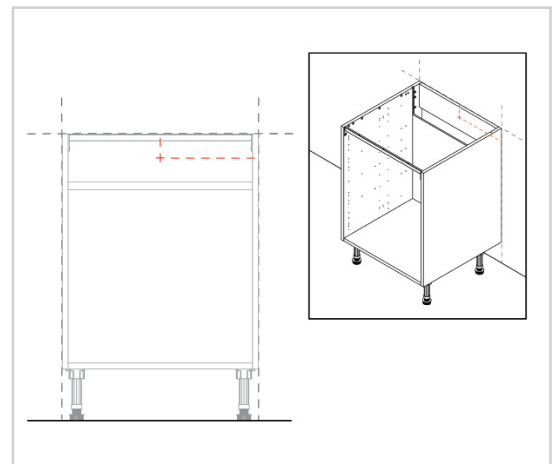

Drilling the cabinet and wall

Drill a hole through both the rear top rail and the wall at the marked locations.

For guidance on the appropriate wall fixing/screws for each wall type, please consult the **“Room Preparation Guide.”**

Once complete, lift and move the cabinet away from the wall, then drill a pilot hole at the marked position.

Lift and reposition the cabinet, ensuring it is level and in line with the wall markings.

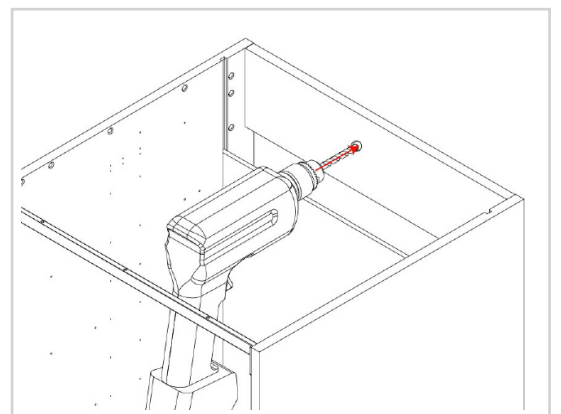

No screws are provided for attaching the cabinet to the wall.
This is due to variations in wall construction.

Inserting the screws

Insert the screws into the drilled hole and tighten to the wall.

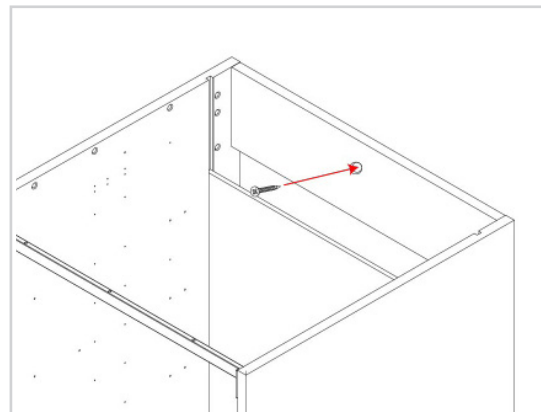

Securing adjacent cabinets

Any adjacent cabinets need to be secured using the **1 1/4"** screws provided. Screw to the rear of both hinge plates and to the rear of the cabinet at the top and bottom.

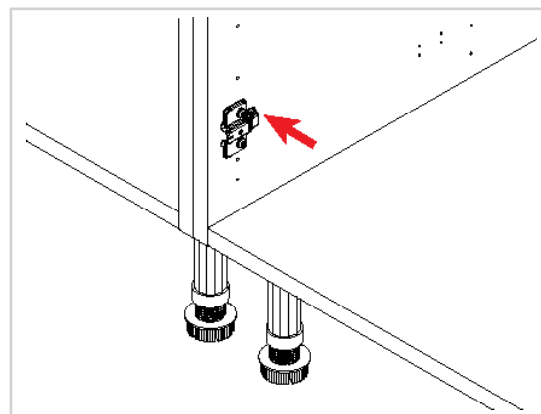

Finding the shelf height

Position the shelf pegs into the pre-drilled holes. The shelf can be positioned at **3** different heights, as shown in the diagram.

Place the shelf in position so the pin of the shelf peg is inserted into the pre-drilled holes.

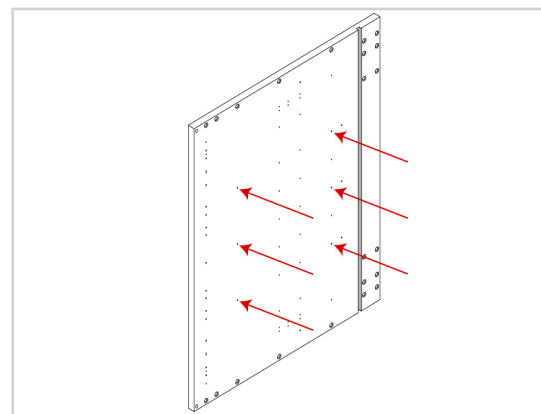

Inserting the shelf into position

The shelf touches the back panel when installed, if there is a gap between the back panel and shelf, then the shelf has been installed back to front, and the shelf needs to be rotated.

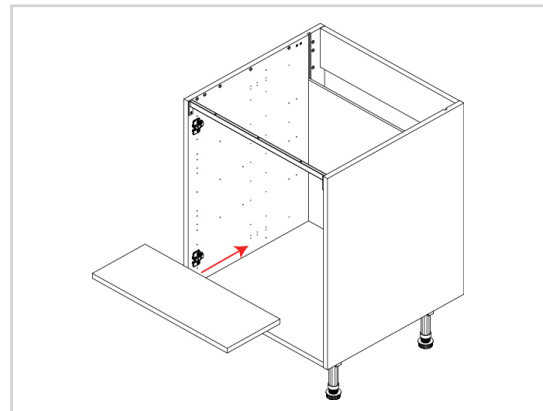

Attaching the frontal

The frontal should be re-attached to the cabinet by clipping the hinges onto the hinge plates.

The bar of the hinge needs to be positioned into the hooks on the hinge plate. Then the rear of the hinge is pushed to the hinge plate until it clicks.

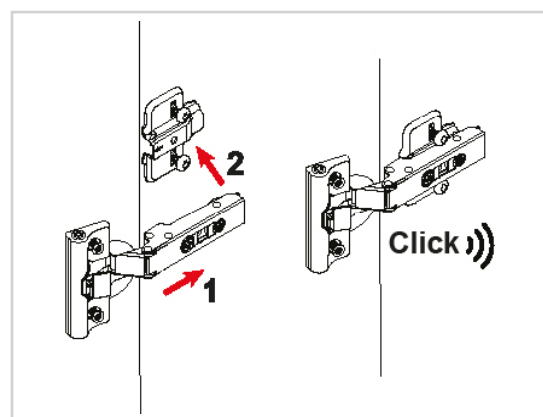

Adding the door buffers

Position door buffers on the cabinet, as illustrated in the images.

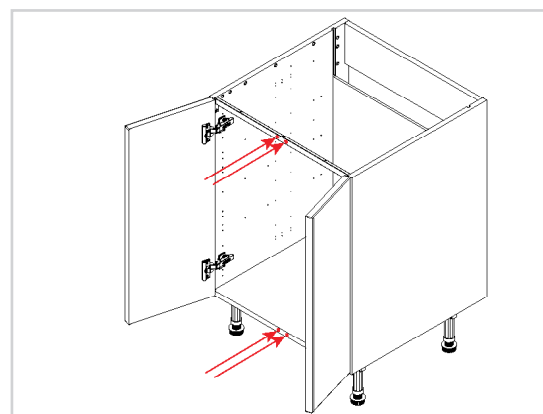
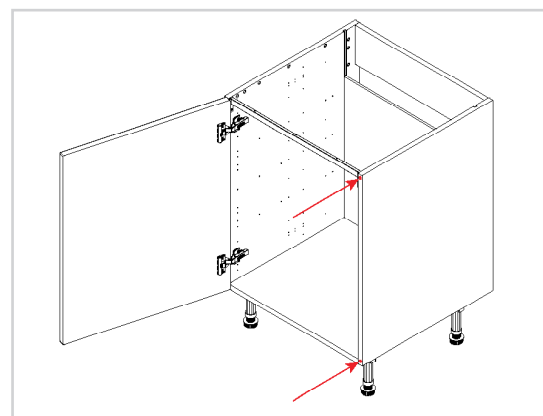

Cleaning the cabinet

Finally, the cabinet should be thoroughly cleaned to remove any debris that may have accumulated during the installation.

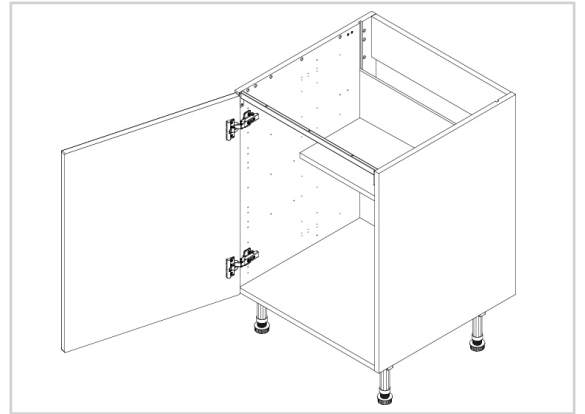

Store the toe kick clips and the remaining 5/8" screws.
These will be used later when attaching the toe kick.

Store the L-brackets.
These will be used later when installing the countertop (laminated or timber).

For door alignment please review the following installation guide:
Door - Door Hinge Adjustment.