



## DOMINA PRO 900 - INDUCTION IN98T



### 4 INDUCTORS TOP

#### TECHNICAL DATA:

External dimensions - WxDxH (cm)	80x90x25
Nr. Inductors 5 kW	4
IPX5	●

#### ADDITIONAL TECHNICAL DATA:

Total power (kW)	20
Supply (N)	400V 3 50/60Hz
Weight (kg)	83
Volume (m3)	0,4

The sealed 6mm ceramic top offers high cleaning comfort thanks to the flat surface and cleanability of glass ceramic. It is watertight fixed to the worktop, preventing any liquid infiltration. The cooking surface only heats up when in direct contact with induction friendly pans and pots, and the amount of heat is proportional to the surface of contact. The zone of the cooking surface not in contact with the pan remains deactivated and thus cold allowing a more comfortable working environment (lower heat emission) and a energy savings equal to 50% compared to traditional stoves. Each inductor has 6 different power levels and an indicator light shows when the top is in operation.

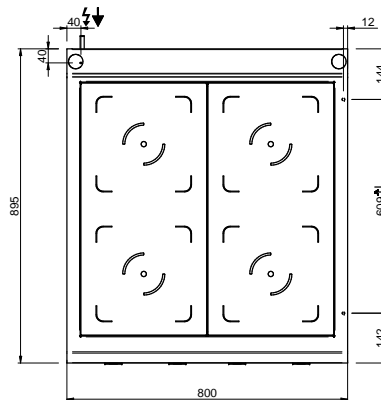
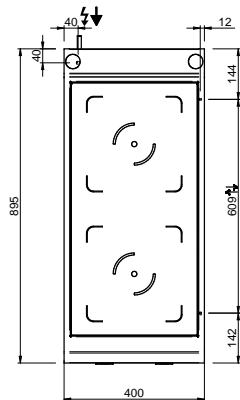
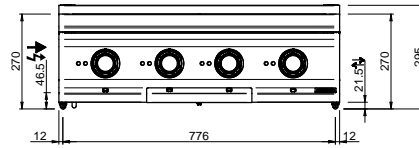
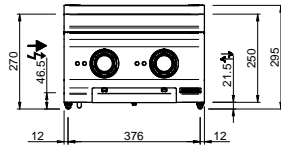

LEGENDA SIMBOLI / LEGEND



INGRESSO GAS / GAS INLET  
(EN 10226-1) Ø M 1/2"



INGRESSO ACQUA /  
WATER INLET Ø M 1/2"



ATTACCO EQUIPOTENZIALE /  
EQUIPOTENTIAL



ALIMENTAZIONE ELETTRICA /  
POWER SUPPLY



SCARICO ACQUA / OLII  
WATER / OILS DRAIN



REGOLAZIONE PIEDINI /  
FEET ADJUSTMENT (h 0/+50)  
/ TOP VERSION (h 0/+5)