



RULEBOOK

2021

2021 NZRCS Executive Committee

President

Aaron Young

027 224 0254

aaron@planitdeziqn.co.nz

Administrator/Treasurer

Sean Challis

021 022 15051

challiss@hotmail.co.nz

Stockcar Technical Officer

Daniel Wheeler

027 975 8555

d_wheeler@hotmail.co.nz

Streetstock Technical Officer

Joshua Gubb

027 268 9737

joshua.gubb@carters.co.nz

Saloon/ Modified Technical Officer

Tyler Walker

027 842 6754

tpwalker33s@gmail.com

Contents

		Page
	Executive Committee Details	1
	Contents	2
1	General	3
2	Technical	4
3	Trial Process	5
4	Radio	6
5	Track Design & Safety	7
6	Code of Conduct	8
7	Protest	9
8	Remit Process	10
9	Transponders	11
10	Stock Silver Can Motor	12
11	Batteries	12
12	Race Meetings	13

Technical Sections

	Page
RC Electric Superstock and Stockcar Rules	20
RC Electric Streetstock Rules	22
RC Saloon Car Rules	24
RC Modified Car Rules	25

Club Contacts	26
---------------	----

Life Members

2013	<i>Jenny Tamanui</i>	<i>Pink Lady</i>
2014	<i>Steve Davies</i>	<i>Mad Maori</i>
2015	<i>Tom Tamanui</i>	<i>Freight Train</i>
2018	<i>Karl McKay</i>	<i>Karlos</i>
2018	<i>John Plowman</i>	<i>JP</i>
2018	<i>Paul McKay</i>	<i>Mackie</i>
2019	<i>Robert Green</i>	<i>Dad Ace</i>
2019	<i>Richard Alexander</i>	<i>Pumba</i>

1 GENERAL

1. This rule book covers the following classes:
 - Radio control 1/10th electric Superstocks (CONTACT class)
 - Radio control 1/10th electric Stockcars (CONTACT class)
 - Radio control 1/10th electric Streetstocks (CONTACT class)
 - Radio control 1/10th electric Saloon Cars (NON CONTACT class)
 - Radio control 1/10th electric Modifieds (NON CONTACT class)
2. Any driver who is a current financial member of a NZ RC Speedway "NZRCS" affiliated Club must hold a NZ Radio Control Car Association Inc "NZRCA" National Racing Licenses which will entitle them to compete at any NZRCS sanctioned race meetings.
An exemption may be made for overseas drivers.
NZRCS Rules apply to Club Days, Club Champs and National events
3. **The license list will be posted on the NZRCA webpage.**
4. Any class must have a recommended minimum entry level of 6 competitors before it can be run at an NZRCS sanctioned meeting. The executive committee will determine whether there is sufficient class numbers to sanction an event. Their decision is final.
5. The following events will be considered an NZRCS sanctioned event.
These events may be run over the different racing classes.
The Executive may add or remove sanctioned events.
 - New Zealand Title – *Superstocks, Saloons, Streetstocks, Modified, Stockcar 540s*
 - New Zealand Under 16's – 540 Motor Only
 - New Zealand Grand Prix
 - North Island Championship
 - South Island Championship
 - New Zealand Superstock Teams Champs
 - New Zealand Streetstock Team Champs
 - New Zealand Stockcar Teams Champs
6. Clubs can't hold the same title meeting in consecutive years unless no other club applies.
Not including team's titles
7. **This "Rule Book" posted on NZRCA webpage after remit process and takes effect on the January 1st each year.**
8. For age limited events, ie under 16's, the age of the competitor is deemed to be that taken on the day of the event.

This rule book is a guide line that must be adhered to.

NOTE: *If it is NOT in here, it does not mean it will be allowed, and final say is at the discretion of the NZRCS Executive Committee*

2 TECHNICAL

1. All cars at NZRCS sanctioned events will be checked by the nominated scrutineer. With the assistance of the NZRCS technical representative for that particular class or if unavailable, with the assistance of a NZRCS representative, other than the hosting clubs representative.
Scrutineer should be technically competent to officiate on that particular class.
2. Technical inspection/**Vehicle Checking must take place before meeting starts. All cars to be presented race ready, (Superstocks plugged in to show 'Blinky' mode).** Cars must be presented for inspection after being requested by the Officials
3. Before, during and after the racing any car may be checked randomly by the Officials for any possible technical infringement. Race distortion or damage is to be disregarded **if checked during and after racing.** Every effort should be made to retain the original scrutinised vehicle
4. 1 competitor may only race the 1 vehicle per class they get scrutineered.
This does not apply to Teams Championships, when Reserve Rule 12.6.c will apply.
5. Responsibility of drivers to ensure that his/her car complies with the regulations at all times that it is on the track.
6. Transmitter may be checked.
7. When a car or transmitter does not comply with the rules, changes must be carried out before presenting it for final approval.
8. No vehicle to race without a securely fitted painted body shell/bonnet.
Superstocks/Stockcars/Modifieds – Includes plastic/alloy wings, body, bonnet and panels.
Streetstocks – Secure body
Saloons – Secure plastic body.
Failure to do so could result in disqualification at the discretion of the race director.
9. Numbers and track Designated Letter *This applies to all classes*
 - Numbers must be a minimum 30mm in height measured from the top to the bottom of the inner number.
 - Track Code must be a minimum 12mm in height measured from the top to the bottom of the inner letter.
 - Numbers and Track Code must not over lap and the Track Code is to be at either the beginning or end of the Number.
 - Must be legible and of contrasting colours EG- light on dark or dark on light.
 - Numbers must be between 4 and 999 with the exception of 1NZ, 2NZ, 3NZ.
 - Numbers starting with 0 are NOT permitted.
 - Superstocks and Stockcars to run Numbers on each Body Sides. Tanks/Spunks may run on each sidepod panels.
Wing Numbers are optional.
 - Streetstocks to run Numbers on each side of the doors or roof.
Fin Numbers are optional
 - Saloons to run Numbers on each side of the body
 - Modifieds to run Numbers on each side of the body and/or wing.

10. All cars must be compressed then released before height measuring is carried out.
i.e. Superstock/Stockcar/Streetstock bumpers and Streetstock roof height
11. Glitch Busters/Capacitors allowed in all classes.
To be plugged into receiver to help aid with radio glitching / interference
12. Competitors and race day officials must wear covered footwear, No Jandals.
13. Track Officials – minimum required.
Race Director – experienced non-competing person who will oversee all other officials.
Race Controller – Controls Race Start/Finishing/Lap Timing
Race Marshalls – A least 2 competent people, may be taken from competitor pool
14. Modules or devices which allow remote adjustment of the ESC (Bluetooth, Wifi etc) via Mobile phone or any other device are not permitted to be attached to the ESC or vehicle during racing.
15. Gyroscope, AVS, Driver Assistance Devices or Electronic Aids of similar effect are not permitted to be used in any class of racing.

4 RADIO

1. It is the responsibility of all drivers to ensure that their equipment does not cause interference to others.
2. Radios must have changeable frequencies.
Entrants should have a spare frequency available when entering a meeting.
3. Or; of the DSM (Digital Spectrum Modulation) type of an approved type to meet the relevant NZ radio standard that is outlined in the Radio communications (radio standard) as set down by Radio Spectrum management, part of the NZ Ministry of Economic Development.
4. Transmitter must not be powered by a voltage exceeding their designed level. Deliberate violation of this rule will result in disqualification from the meeting.
5. Changing of a frequency during a meeting without letting the Race Director know **may** result in disqualification from the meeting.
6. Only the following list of frequencies may be used, with the exception of DSM users. The penalty for not complying with this list of frequencies is that the operator (ie the driver) is liable for a fine up to \$10,000 plus loss of radio equipment.
7. A frequency peg board or notice board should be used.
8. A transmitter pound may be used at the discretion of the organizer.
9. The Race Director will have the final say on any issues in respect of radio frequency and transmitter issues.

LEGAL FREQUENCIES

27 mhz	29 mhz	35 mhz	36 mhz	40 mhz	72 mhz
26.975	29.725	35.45	36.05	40.660 - 40.700	72.250 - 73.000
26.995	29.745	35.55	36.15	40.800 - 41.000	
27.025	29.765	35.65	36.25		
27.045	29.785	35.75	36.35		
27.075	29.805	35.85	36.45		
27.095	29.825	35.95	36.55		
27.125	29.835				
27.145	29.845				
27.175	29.855				
27.195	29.865				
27.225	29.875				
27.255	29.885				
	29.925				
	29.935				
	29.945				
	29.955				
	29.965				
	29.975				
	29.985				

Frequencies which are strictly prohibited include:

29.775 – 29.785, 29.890 – 29.910, 40.500 – 40.660, 40.700 – 40.800, 75 mhz

5 TRACK DESIGN & SAFETY

1. All tracks at sanctioned NZRCS events must be constructed of wood, alloy or steel or combinations thereof. Other materials must be approved by the Executive Committee.
2. All tracks must have a safety or catch fence that is a minimum height of *300mm* off *the racing surface and consist of a minimum of 3 wires*.
3. Where practical a further safety barrier should be used to keep viewers safe.
4. Where practical the track should retain its original shape during the racing, including the infield.
5. If the Executive Committee deem the track to not meet the required standards the track can be repaired, replaced or amended until such time as it does meet those requirements. Their decision is final.
6. All tracks should have at easy access first aid box, fire extinguisher & car bin with lid. These should be displayed and highlighted there locations at the drivers brief prior to the start of the race meeting.
7. No grip or de-gripping compounds to be added to tracks when hosting National events.
8. All tracks are to have secured 'exit / track entry' ramp / ramps positioned in the infield on the back straight, or sections of the infield, to allow cars knocked from the track into the infield to re-enter the race and not be stuck.
9. Transponder loop and start/finish must be on the same straight of the track.

6 CODE OF CONDUCT

INAPPROPRIATE BEHAVIOUR PENALTIES

1. The NZRCS Executive reserves the right to issue fines/suspensions to member/s for inappropriate behaviours towards any NZRCS Executive or member. Inappropriate behaviour includes on the use of public forums or social media.

The NZRCS Executive can issue any or all of the below:

- (a) Reprimand which can be private or public.
 - (b) Relegate finishing positions.
 - (c) Exclude from the results of the event.
 - (d) Suspend NZRCA Licence for an infinite number of days, starting from the date of the offence.
2. When a complaint is heard, the NZRCS executive shall meet with a minimum of the President, Secretary, Treasurer, the 1 Technical Officers and the Club Executive Committee of the parties concerned to be fully informed of the meeting taking place and the outcome.
 3. Members wanting to make a formal complaint are to submit their complaint in writing to the NZRCS with all appropriate evidence, and must be supported with a fee of \$20 that will be refunded if the complaint is upheld.

7 PROTESTS

1. All protests can be verbally made to the Race Director within 10 minutes of the completion of the race concerned.
The protest must then be made in writing accompanied by a \$20 protest fee (refundable if protest upheld).
The protest will be considered by the Protest Committee.
2. Only competitors from the race concerned may launch a protest, except in Rule 1.6 Code of Conduct protests.
The person being protested against has the right to defend themselves before the protest Committee.
Should a member of the protest committee be involved in the protest, they are to be excluded from deliberations, but may nominate a person from their home Club to present a defence.
3. The Race Director must decide the appropriate time to hear a protest.
If the protest concerns the immediate running of the meeting the race schedule may have to be delayed for the hearing of the protest.
If the protest does not concern the immediate running of the meeting the Race Director can adjourn the protest until a more appropriate time.
4. If no protests are received within the 10 minute period the provisional results become the "Official Final Results".
5. The applicant of a protest can not appeal against the decision.
6. The Race Director, after consultation with his/her organising staff, may without a protest being made, correct results that they deem necessary.
7. Protest against the decisions of the Protest Committee is not possible.
The Protest Committee decision is final.
8. Protest committee at NZRCS sanctioned meetings must be made up of a fair representation of the number of clubs present at the event

8 REMIT PROCESS

1. Remits (notices of motion) must be submitted in accordance with Clause 4.2 NZ RC Speedway Handbook.

On the 1 st JUNE	Remits documents sent out
By 31 st JULY	Remits Close
By 31 st AUGUST	All remits correlated and sent out for Club Votes
By 31 SEPTEMBER	Remit club votes close
By 31 st OCTOBER	Admin to correlate club votes and send to executives for review
By 31 st NOVEMBER	Executives except
1 st DECEMBER	Results published and reissue of rule book.

Changes take effect 1st January.

2. Remits can only be made by affiliated Clubs and not individual NZRCS members.
3. **A remit must receive 60% of the total votes of voting clubs per remit to go through. An abstain vote will not count as a vote.**
4. The NZRCS Executive Committee has the right to amend rules throughout the year but they must go through the club voting process and gain a majority of the votes for the rule change to be passed.

9 TRANSPONDERS

1. Will be used, but no penalty for a competitor choosing to not use one.
2. Where ever feasible, **an** AMBrc Transponder System will be used.
3. It is every driver's responsibility to make sure transponders are working and fitted/attached correctly, so as to not detach during racing.
All club handout AMB transponder mounts must be correctly welded between the frame rails with a 7mm hole in them.
The size of the mount required is 40mm x 40mm x 1.2mm steel.
All sizes are minimum requirement.
It also required that a foam pad be placed over the steel to hold the transponder rigid.
Alternative Plastic holder with felt padding is acceptable.
These have to be checked and approved by NZRCS Executive to ensure the Transponder is kept safe and securely mounted in car.
4. AMBrc Transponders unless they are personal transponders are NOT allowed to be affixed directly to the body or bonnet. Loan transponder to be mounted in mounts approved by the NZRCS Tech Rep.
5. The Hosting club, before the start of an event will complete a transponder check of all competing vehicles to ensure the hosting clubs hardware is receiving the competitor's transponder signal.
6. It is the responsibility of the competitor to ensure the Hosting clubs hardware receives a clear signal from the competing vehicle.
7. If the Competitors vehicle signal is lost or not received during or part way through a race, no dialog will be entered into.
8. Manual lap scoring won't be permitted.

10 STOCK SILVER CAN MOTORS

1. Only permitted motors are unopened, unmodified 27 turn Johnson 540 or Mabuchi 540 closed can, sealed end bell, bushed, with non-replaceable brushes and bushes.
2. These will be Mabuchi RS540sh, Johnson 540-J
3. Tamiya Mabuchi "Sport Tuned" or "Torque tuned" 25 turn motors are not allowed, nor any other variants such as 540st or 4 hole variants etc.
4. A stock motor run at 8 volts unloaded must draw no more than 1.7amps.
5. The "zapping" of a stock motor is classed as a modification and thus illegal.
6. If stock motors are provided by the organizers they are not allowed to leave the grounds of the host club at any time over the period of the sanctioned meeting.
7. Torque sleeves are not permitted.

11 BATTERIES

This applies to all classes. Must be secured to the inside of the vehicle.

Hard Case Lithium Polymer (Lipo)

1. The use of Lipo Batteries is to be as per the following mandates.
2. Batteries are to be Lipo 2S 7.4v or LiHV 2S 7.6v ONLY
3. Maximum Charged Voltage of 8.4v. **All 7.6v HV Lipo batteries are to be checked before racing on an approved volt meter supplied by NZRCS.**
4. Lipo/LiHV Lipo Batteries MUST be removed from vehicles and charged in a closed Lipo Bag at all times.
5. All Lipo/LiHV Lipo Batteries MUST be Hard Cased (Excluding Transmitter battery packs)
6. The use of LiHV Lipo Battery packs is allowed, providing the charged battery voltage does not exceed that stated in Rule 11.3
7. Failure to comply with any of the above rulings shall result in the competitor disqualified from the event and face the NZRCS Committee for any further disciplinary action.

NiCd & NiMH Batteries

1. Must consist of 6 x 1.2v 'Sub C' sized cells totalling 7.2v
2. Battery capacity is open

12 RACE MEETINGS

12.1 NZRCS SANCTIONED EVENTS

- a. The Organiser of the event is responsible for ensuring competitors and officials are aware of the race program and timetable.
- b. All vehicles will be scrutineered and subject to technical rules before the event begins. Any vehicle wishing to race must pass said scrutineering (including any re-checks) before the vehicle is allowed on the track.
If it does compete without passing scrutineering then its results will not count and the competitor may be subject to disciplinary action.
For teams events the teams result will not count and the opposing team will score full points.
- b1. All finalists within all classes of an NZRCS National Championship must be left on the track after the finish of the third and final heat whilst cars (a minimum of at least the top 6) are selected for Re-Scrutineering - **Cars may be turned off/Batteries disconnected while on track. Anything else will be deemed as car tampering and will lead to disqualification.**
- b2. After a Teams last race of a NZRCS Teams National Championships, all cars are to be left on the track, and 6 vehicles will be randomly selected from both teams for Re-Scrutineering - **Cars may be turned off/Batteries disconnected while on track. Anything else will be deemed as car tampering and will lead to disqualification.**
- b3. **Re-Scrutineering is to include the checking of motors, ESC in stock/blinky mode (Superstocks) and car weights. If found to be illegal, you will be disqualified from the meeting and may face further punishment from NZRCS, I.E Illegal motor.**
- c. A drivers briefing must be held prior to each race day. All drivers and officials must be present.
- d. The race director for the day must not be competing on that day he/she is a race director of.

The following items should be covered:

- Introduction of Race Director and other officials
- Security and safety
- Starting procedure
- Finish procedure
- Red Light
- Protest rules and officials

12.2 RACE - START/FINISH

START

- a. The number of starters permitted to start in any race will be decided by the Race Director, and his decision will be final and binding.
- b. When the Race Director calls the race, vehicles must line up in the grid they have drawn.
- c. If you are unable to make it you can call for 2 minutes.
Only 1 2-minute audible sound (or such means) be able to be heard for all competitors per race can be called.
- d. Deliberate aggressive contact before a race is strictly forbidden, and may result in disqualification.
- e. Race will commence after the sequence of audio beeps from the Lap Scoring system or Start Horn.
- f. During this countdown period, vehicles must remain stationary.
Deliberate movement of vehicle is strictly forbidden and may result in disqualification.
- g. Creeping vehicles deemed to be caused by Radio issues may be removed from their starting positions and placed at the rear of the field front bumper flat against the outer wall until the race has commenced.
- h. If movement is accidental, correct grid position may be retained before race commencement without further repercussions.
- i. It is the driver's responsibility to retain correct grid position.
- j. Race Restarts, if called by the race director Cars must be immediately re gridded no repairing or removing of cars from the track for the purposes of repairs.
Competitors must not touch their cars.
- k. Vehicles may not start racing until the final countdown beep or start horn is sounded.
At this time a GREEN light may be displayed.
- l. **All vehicles must race in the correct direction. Any reversing off the start line will result in disqualification. (to be watched and judged by race director)**
- m. False starts will be at the discretion of the Race Director, who may restart the race, or disqualify offending vehicle.
All vehicles must re-grid again if called by the Race Director.

FINISH

- a. Race completion will be by means of an audible sound.
- b. Racing will continue until all able vehicles have completed the lap they were on when the end of race is called.
- c. At completion of this lap, an audible sound may be heard, and/or RED lights may be displayed.
- d. All vehicles must then come to a complete STOP, and vehicles are to be safely removed from the track as soon as possible.
- e. Vehicles may be driven SLOWLY to aid in extraction from track.
- f. Racing or deliberate hitting after the race is completed will NOT be tolerated, and disqualification may result.
- g. To be classed as a finisher, your vehicle must complete the final lap of the race (Your car may be pushed across the finish line, ONLY if the pushing vehicle has not completed the final lap).
All non-finishers will receive a DNF
- h. Race results at national events must be posted for competitors to see within 10 minutes from the end of the race.

12.3 RACE FORMAT

- a. Qualifying
3 Qualifying Heats per group (Open group numbers)
15 laps per race (Race numbers depending on groups)
- b. Finals
3 Final Heats 20 laps per race
(The number of finalists at a national meeting must be 20 cars for contact classes, the maximum number allowed for non-contact classes, or the minimum available cars for the event)

12.4 RED LIGHTS

- a. If your vehicle is rolled onto its side or roof and is unable to continue, the race will be stopped, and the vehicle will be removed from the track by a Race Director / track Official and receive a DNF.
- b. Competitors cannot remove vehicles during racing.
If you require your vehicle to be removed, hand must be raised above your head, and the attention of the Race Director is required.
Under their discretion, race may be stopped, and vehicle removed by a Track Official.
- c. If battery or any other electronics becomes dislodged and is deemed dangerous and/or is deemed to hinder in the control of the vehicle by the Race Director/Track Official, the race will be stopped, and the vehicle removed by a Track Official, and will receive a DNF.

12.5 RACE IN PROGRESS

- a. During racing, competitors shall take all proper care.
- b. Stationary vehicles are to be avoided wherever possible, and competitors will not attempt to force or steer other vehicles into stationary vehicles. *"This rule does not apply for teams racing"*
- c. Vehicles must race in an anti clockwise direction, or clockwise as directed by Race Director for Streetstocks only.
- d. Where the class is defined as a Non-Contact class then no deliberate contact is allowed.
- e. Should a competitor find himself in a position where he cannot drive in the correct racing direction, he must not attack until in the correct position, defined as anywhere from a right angle back to the direction of flow of traffic.
- f. Attacking from a stationary position or hitting stationary vehicles is not permitted and may result in disqualification.
- g. Those who wish to wait for an opposing member should be moving, however slowly at all times in the correct direction (it must be remembered that this competition is called racing and parked vehicles are not to be considered as part of the competition).
- h. Any competitor using the inside or outside wall as an advantage, including attacking from and using it as an aid to get around the track, IN THE OPINION OF THE RACE DIRECTOR may be disqualified.
- i. Any competitor deliberately driving infield (except to avoid oncoming cars) for a sanctuary (to gain advantage) may be disqualified.
- j. Any competitor purposely driving in the opposite direction may be disqualified.
During racing, the race may be stopped at any time by the Race Director and/or the Lap Scorers. This is done by audio sound and/or a RED light.
At this time ALL vehicles must cease from racing, and come to a complete STOP.
HOWEVER vehicles must move slowly forward and away from the NO STOPPING ZONE near the transponder bridge.
- k. Vehicles must NOT move unless requested by Race Director, failure to do so, may result in disqualification.
- l. Racing will recommence by audio sound and /or a GREEN light.
- m. A vehicle moving forward before this time may be disqualified
- n. Only a race director or nominated official can remove a car or cars from a race due to an infringement.
If an official has seen an infringement then he/ she has to let race director know so race director can action accordingly.
- o. **Spotters are NOT allowed in any forms of Teams or Individual Racing. Non racing drivers must stand away from the designated racers area, this includes a teams 5th or 6th driver. Permission can be requested from the NZRCS committee for junior classes only.**

12.6 TEAMS RULES

- a. Superstock and Streetstock teams are to be made up of a maximum of 5 vehicles, with a minimum of 4 drivers per team.
- b. Stockcar teams are to be made up of a maximum of 6 vehicles, with a minimum of 5 drivers per team.
- c. General National Race Meeting rules will apply.
Entry fee is at the discretion of the hosting club.
A driver may only enter and race for a single team.
A driver entered in one team may be designated to 'spot' for another team but is not allowed to race for them, nor is that designated spotter allowed to change once racing has commenced.
- d. Which 4 vehicles are up to the discretion of the respective team.
- e. **RESERVE RULE:**
The team's 5th vehicle (6th vehicle in Stockcar teams events), is the reserve vehicle.
Replacement can be made at any time up to race commencement.
Each member of the team can race any of the teams' scrutineered cars.
Substitution may also be made during the gridding process.
A 2-minute call may be made to substitute vehicles (if a 2 minute call has not been made already).
Once the race has commenced, there will be NO substitutions
- f. Team winning Team Champs can Host it consecutively unlimited years
- g. **CLUB TEAMS**
Each club is able to enter a maximum of three teams.
All team members to be current financial club members of the club they are representing and be registered to NZRCS.
- h. **WINNING TEAM**
The winning Team gains title and the Teams Club gains hosting rights
- i. **SELECT TEAMS**
Select Teams are to consist of a maximum of 5 vehicles, a minimum of 4 drivers from various clubs per team, with a maximum of 2 team members from a particular club.

NORMAL TEAMS RULES APPLY
Before the event the Team must nominate which club they will give hosting rights to should they win.

WINNING SELECT TEAM
If the Select Team wins the Teams Nationals, the Team gains title but hosting rights go to their nominated Club
- j. **STOCKCAR TEAMS**
Generic Team Rules above will apply.
Exceptions
1: Maximum 6 vehicles per Team, with a minimum of 5 drivers.
2: Maximum 5 vehicles from each team (maximum total 10 cars) per race.

3: Motors must be Stock 27 turn as per Rule 10 Stock Silver Can Motors.

k. POINTS

NZRCS Sanctioned Teams Events to run the following points system...

1st 100

2nd 40

3rd 25

4th 20

5th 10

l. The format for NZRCS Sanctioned Teams Events MUST be one of the following:

- Full "round robin" format
- Full "round robin" format with semi finals and finals.
- Qualifying & Finals Format:
At the hosting clubs discretion

FINALS FORMAT:

Semi Final's

1st vs 4th

2nd vs 3rd

Consolation (for 3rd & 4th overall)

Semi 1 Loser vs Semi 2 Loser

Final (for 1st & 2nd overall)

Semi 1 Winner vs Semi 2 Winner

It is at the hosting clubs discretion if they would like to host a B & C main final to give all teams some racing in the finals.

TECHNICAL SECTIONS

SUPERSTOCKS AND STOCKCAR RULES

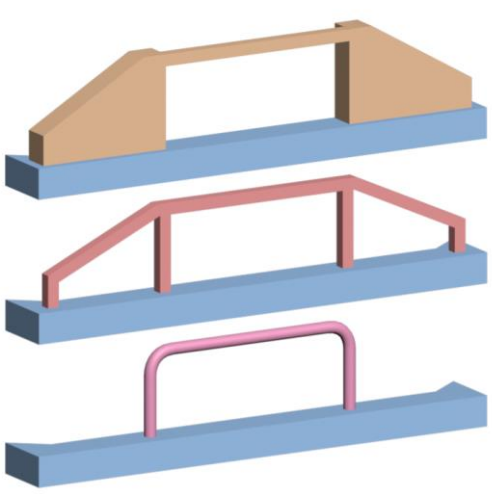
1	Chassis	Constructed of steel, stainless steel, and/or aluminium
2	Donor Vehicles	1/10 Scale ONLY Donor type is open Donor make is open
3	Drive Train	4wd or 2wd is allowed
4	Vehicle Weight <i>Race ready incl battery</i>	Minimum: 3.500kgs Maximum: 4.500kgs
5	Vehicle Dimensions	Maximum Width – 320mm Maximum Length – 450mm
6	Bumpers	(Includes front, rear and sides) Minimum height of 20mm (Measured from the ground to the bottom of the bumper) Maximum height of 40mm (Measured from the ground to the bottom of the bumper) Must sit proud by a minimum of 3mm of anything below bumpers. (Excludes Wheel Guards)
7	Rear Wheel Guards	(Excluded from bumper measurements) Can be fixed to chassis or removable Maximum 100mm in Length Maximum 25mm in Height Maximum 14mm in Thickness Must not exceed past the bottom of the baseplate.
8	Front Hoop	All cars must run a hoop above the front bumper Minimum height of 60mm (measured from the ground to the top surface of the hoop) Minimum width of 75mm (measured between uprights) The overrider and extra braces must be at 90 degrees with the front bumper for a minimum of 12mm measured vertically. (see diagram attached) 

9	Front Bumper to Side Rail Clearance	Side rails must finish in line or behind the rear edge of the front rim Minimum clearance of 60mm. If front bumper damage occurs during racing, every effort must be made to correct. (At track Marshall and RC speedway committee's discretion)
10	Motors	<p><u>10A Brushed Motors</u></p> <ul style="list-style-type: none"> • Must be a factory 23 or higher turned motor • Must have a factory fixed end bell and can • Adjustable timing is not allowed • Brushes Springs and bushings are allowed to be replaced with aftermarket items <p><u>10B Motors 540 Stockcar</u></p> <ul style="list-style-type: none"> • Silver Can standard as per Clause 10. 540 only (27 Turn) • Aftermarket alloy hop up heat sinks are allowed <p><u>10C Brushless Motors</u></p> <ul style="list-style-type: none"> • One: 540 size 17.5 turn brushless motors as per <i>ROAR</i> approved list only. • It is the responsibility of the competitor to prove that their motor has the correct number of winds to comply with this rule, an inspection can take place at any time by NZRCS or the race director should they deem necessary. • Type and brand of ESC used is open, but must be either 'Stock Spec' (have no boost/turbo or timing advance programming) or be running in 'blinky' mode
11	ESC Speedcontroller	<p>Superstock Brushed ESC</p> <ul style="list-style-type: none"> • Open to any ESC <p>Superstock Brushless ESC</p> <ul style="list-style-type: none"> • Open to any ESC • Must be run as "Stock Spec" or in "Blinky" Mode. I.E Have no boost/turbo or timing advanced programming. • ESC can not be altered during racing as per Technical Rule #14 <p>Stockcar ESC</p> <ul style="list-style-type: none"> • Open to any ESC
12	Batteries	Refer Technical Rule 11
13	Wheels and Tires	Must be of 1/10 scale Tyre choice is open Tyre grip aiding compounds are not allowed

<p>14</p>	<p><i>Bodies, Bonnets & Wings</i></p>	<p>Superstocks/Stockcars must run either, a plastic/fibreglass NZ Style Stockcar body and bonnet or NZ Rees style skeleton panels, roof panel, Side Panels and Stockcar bonnet.</p> <p>Body, body panels and bonnet must be securely fitted on race commencement. As per Technical Rule # 8. This does not include race damage from that race meeting.</p> <p>NZ Style Wings must be confined to within the roof area of the body or Roof panel. They must not extend in front or behind and be confined to the drip rails either side of the roof/roof panel. They are to be mounted on the roof area, not on the front visor.</p> <p>Bodies, panels and bonnets must not be changed unless damaged beyond all repair. The Race Director must be informed before the change is made.</p> <p>Clear Body and bonnet must have a colour applied in full. Running a clear body and bonnet is unacceptable.</p>
<p>15</p>	<p><i>Numbers</i></p>	<p>Refer Technical Rule 2.9</p>
<p><i>NOTE</i> your vehicle must resemble a STOCKCAR, not a box on wheels. Running gear can be replaced, but must retain the same steel Stockcar chassis throughout the meeting</p>		

STREETSTOCKS RULES

INTENTION OF THIS CLASS

This class is a "feeder" class. Aimed at new and existing competitors.

The intention of the class is to be a breeding ground for future racers and or a class for people on a low bud

DONOR CAR

1	Donor Car	Donor car is to be Tamiya "TT01, TT01D or TT01E"
2	Motor	<ul style="list-style-type: none">• Standard 540 Silver Can as per Rule 10 STOCK SILVER CAN MOTORS• Aftermarket alloy hop up heat sinks are allowed. <p>Wires can be removed and either 1, Hard wired from ESC. or 2, replaced with thicker gauge wire and alternative plugs fitting, Deans etc.</p> <p>NOTE: If you are found to have an illegal motor or armature, you are liable for a 1 year stand down from racing. If you are caught again after a stand down, you will be banned for life.</p>
3	ESC Speedcontroller	ESC (Speed Controller) Tamiya "TBLE 02s" "TEU101BK", TEU104BK", "TEU105BK" and "HOBBYWING 1060" speed controllers only. Aftermarket plugs (ie Deans etc) are allowed. Aftermarket <i>Glitch Busters / capacitors are allowed.</i> To be plugged into receiver to help aid with radio glitching / interference.
4	Parts	Donor cars must be made of plastic materials only. No alloy hop up parts, Carbon fibre or steel aftermarket parts. All plastic parts must be Tamiya manufactured parts only (composite plastics are allowed) Any bearings are allowed Any steel screws, nuts and bolts are allowed Tamiya plastic 2 degree rear hubs (part number 53673) are allowed. Tamiya servo saver (part number 51000) is allowed.
5	Wheels and Tires	Tyre and wheel choice is open but no wider than 30mm. Radial type tyres only, NO Pin style tyres allowed. Tire grip aiding compounds are not allowed
6	Shocks	Shocks must be Tamiya manufactured plastic (oil filled allowable). Any spring allowed. No sway bars.
7	Batteries	Refer Technical Rule 11

8	<i>Differentials</i>	Standard differentials only (No one way, ball or locked diff's). Must spin freely. Gearing must be 61 Tooth Spur and 19, 20, 21 or 22 Tooth Pinion.
9	<i>Battery Posts</i>	Battery posts (front and/or rear) may be removed or modified and replaced with hand fabricated items. Battery brace / strap may be removed or modified and replaced with hand fabricated items.
10	<i>Numbers</i>	Refer Technical Rule 2.9

FABRICATION SPECIFICATIONS

1	Must resemble a Streetstock, Panel Wagon, Coupe (two doors) sedan (four doors) station wagon and panel van (Falcon type) body styles only. No Utes, Cargo Vans (Hiace type) or buses. All windows must be removed.
2	<i>All Body panels (including bonnet and roof) and baseplates</i> to be constructed from Steel or Aluminum ONLY Any car that loses its body during a race will be disqualified.
3	Maximum width (including bumpers) is 230mm
4	Minimum height ground to top of roof, excluding fin, is 120mm
5	Bumpers are to be constructed of either 6mm OD round maximum or 6mm square maximum. Roll Cages and Radiator Hoops are Optional
6	Furniture tube (square or round 12.7mm OD maximum) can be used as an alternative front bumper only, but must be wrapped with 6mm OD round or square maximum. There must also be a minimum gap between them of 6mm. No more than 3 spacers can be used between them. No over riders or under riders are allowed on front bumper. Radiator hoops must be part of the body or beneath the body not in front of it
7	The maximum amount of furniture tube (square or round) of any size (larger than 6mm OD) allowable in the complete construction of any Streetstock is 250mm maximum.
8	Bumper heights are to be a minimum of 20mm (measured from the ground to the bottom of the bumper). Must sit proud by a minimum of 3mm of anything below bumpers. (see diagram attached)

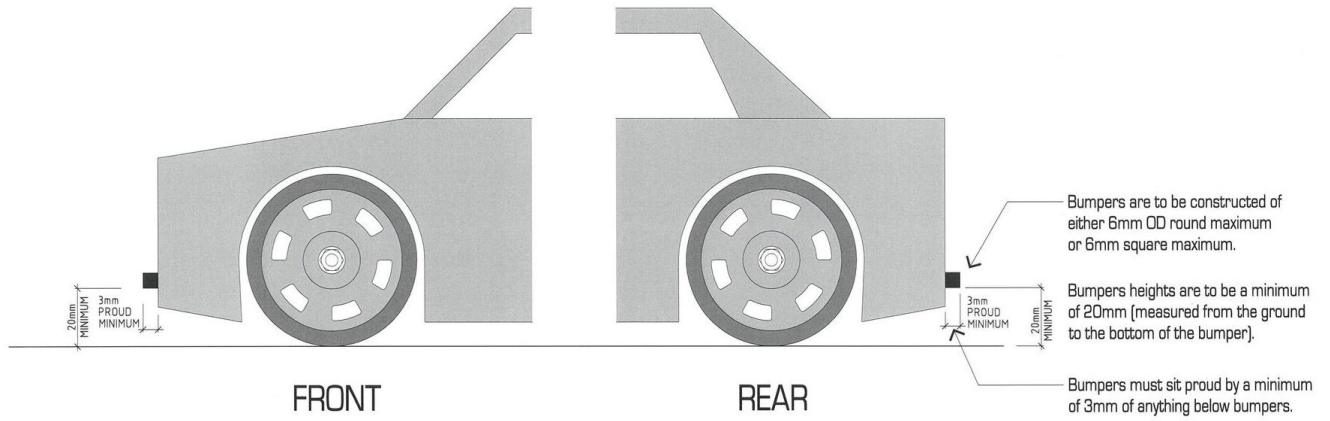

- 9** Cars to be weighed race ready *with* battery.
 Minimum weight: *3.300kg's.*
 Maximum weight: *3.600kg's.*
- Additional weights can be used but must be drilled and bolted to solid structure of the car

SALOON RULES

1	Saloon cars must be 1/10 th On-Road Car Homebuilts allowed
2	Batteries Refer Technical Rule 11
3	Radio Gear – Open
4	Tire choice is limited to radial tire patterns only No pin style tyres allowed Tire grip aiding compounds are not allowed
5	ESC open
6	<i>Motor</i> Silver can standard as per Clause 10: 540 only (27turn). Aftermarket alloy hop up heat sinks are allowed
7	Body must resemble a Saloon car, all windows must be cut out or left transparent (clear). Wings must be speedway style not touring style, ie base of wing must be flush with boot lid. No pedestal type wings.
8	Any Hop ups are permitted
9	No alloy or steel plates protruding from the chassis in any direction
10	Numbers Refer Technical Rule 2.9
11	Cars to be weighed race ready with battery Maximum Weight: 2.000kg's

RACE RULES

- Race length to be decided by event organizer.
- Non contact.
- Raced anti clockwise.
- Deliberate contact will be black flagged.
- Minimum of 6 cars -Maximum of 12 cars per heat.

The event is not limited to 12 cars

MODIFIED RULES

1	1/10th on road donor <i>Must resemble a New Zealand Modified class vehicle.</i>
2	No mini pins, rally blocks, must be radial, slick or drift tires
3	Motors and batteries are open
4	Batteries Refer Technical Rule 11
5	Brushless motors ok
6	2 or 4 wheel drive allowed
7	Rolling starts
8	Qualifying fields to be determined by host club Finals to have a max of 8 cars
9	Numbers Refer Technical Rule 2.9
10	Weight with battery Minimum 1.8KG Maximum 2.6KG

Club Contacts and Details

Auckland Sean Challis challiss@hotmail.co.nz	Bay of Plenty Tony Clarke Tony.Clarke@calisuzu.co.nz
Hawkes Bay Richard Alexander richiea41b@gmail.com	Nelson Nathan Harvey nelsonrcspeedway@gmail.com
Christchurch Barbara Hansen chchrcstockcarclub@gmail.com	Palmerston North Darian deRidder darian@advancedsheetmetals.co.nz
Gisborne Liam Wire liamwire17g2016@gmail.com	Taranaki (Stratford) Aaron Young aaron@planitdezygn.co.nz
Greymouth Peter Toal mcdoin@hotmail.com	Horowhenua (Levin) Stu Russell stockyboynz@gmail.com
Huntly Geoff Webb gwmotorsport@gmail.com	Wanganui Tanya Chaplow chappys_lot@xtra.co.nz
Taupo Steve Davies madmaori@orcon.net.nz	Wellington Cam Rollo rcspeedwaywellington@gmail.com

Most Clubs are on Facebook