

EFM[®]32

... the world's most energy friendly microcontrollers

USB Hardware Design Guide

AN0046 - Application Note



This application note gives recommendations on hardware design for implementing USB host and device applications using USB capable EFM32 microcontrollers.

This application note includes:

- This PDF document
- USB Verification Report

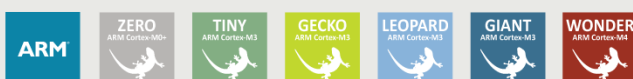

1 Introduction

Some EFM32 microcontrollers, for instance selected members of the Giant Gecko and Leopard Gecko families, offer on-chip USB support. The USB peripheral embedded on these devices include the USB PHY and an internal voltage regulator, thus requiring only a minimum number of external components. The on-chip voltage regulator's primary purpose is to power the EFM32 USB PHY. But as it can deliver more current than the EFM32 needs, it can be used to power other components as well, even in non-USB applications. This can be very useful when component cost or PCB area is of concern.

This document will explain how to connect the USB pins of an EFM32 microcontroller, and will give general guidelines on PCB design for USB applications. First some quick rules-of-thumb for routing and layout are presented before a more detailed explanation follows.

The information in this document is meant to supplement the information already presented in Energy Micro application notes AN0002 Hardware Design Considerations and AN0016 Oscillator Design Considerations, and it is recommended to follow these guidelines as well.

The EFM32GG-STK3700 has been tested and passes the requirements as a USB Device. A test report confirming this is attached.

2 USB Connection

This section gives a brief overview of the different USB roles an EFM32 Microcontroller is capable of. For more in-depth details, please refer to the device family reference manual.

USB can be operated in 2 different modes; host or device, with hub being a special version of a USB device. A supplement to the USB standard introduces "On-The-Go" mode, which enables a USB product to operate as either a host or a device depending on which kind of controller is in the other end of the cable. A typical example for this would be a smartphone or a tablet that can both connect to a computer as a USB Mass Storage Device, or act as a host if a memory card reader or a USB memory stick is connected.

A USB capable EFM32 microcontroller can operate as a host, a device or as an OTG dual role device. EFM32 microcontrollers do not support operation as a USB hub. The Energy Micro provided USB stack only supports host mode and device mode.

2.1 EFM32 USB Pin Descriptions

The USB peripheral on EFM32 microcontrollers feature the following pins:

USB_DP - Data line

USB_DM - Inverted data line

USB_VBUS - Sensing if VBUS is connected.

USB_VBUSEN - VBUS Enable, a control signal for enabling VBUS in host applications. Connect to external VBUS switch.

USB_DMPU - Data Minus Pull-Up, a control signal for enabling external 4.7 kohm pull-up on USB_DM for low-speed operation. If VDD is 3.3 V pull-up may be connected directly to USB_DMPU pin.

USB_ID - ID for determining which device should act as bus master in a link between two OTG Dual Role devices. Connect to ID pin on USB Micro-AB receptacle.

USB_VREGI - Voltage regulator input.

USB_VREGO - Voltage regulator output.

2.2 EFM32 as USB Host

In host mode, the EFM32 acts as the bus master and is responsible of enumerating the USB devices, a process that includes inquiring connecting devices for configuration information and assigning them an address on the USB bus. The USB host also controls data flow on the bus by sequentially polling all devices for data, meaning that no device can transmit on the bus without a host request.

A USB host must be able to supply power to a connected USB device through the +5 V VBUS line.

Figure 2.1. USB Host Schematics

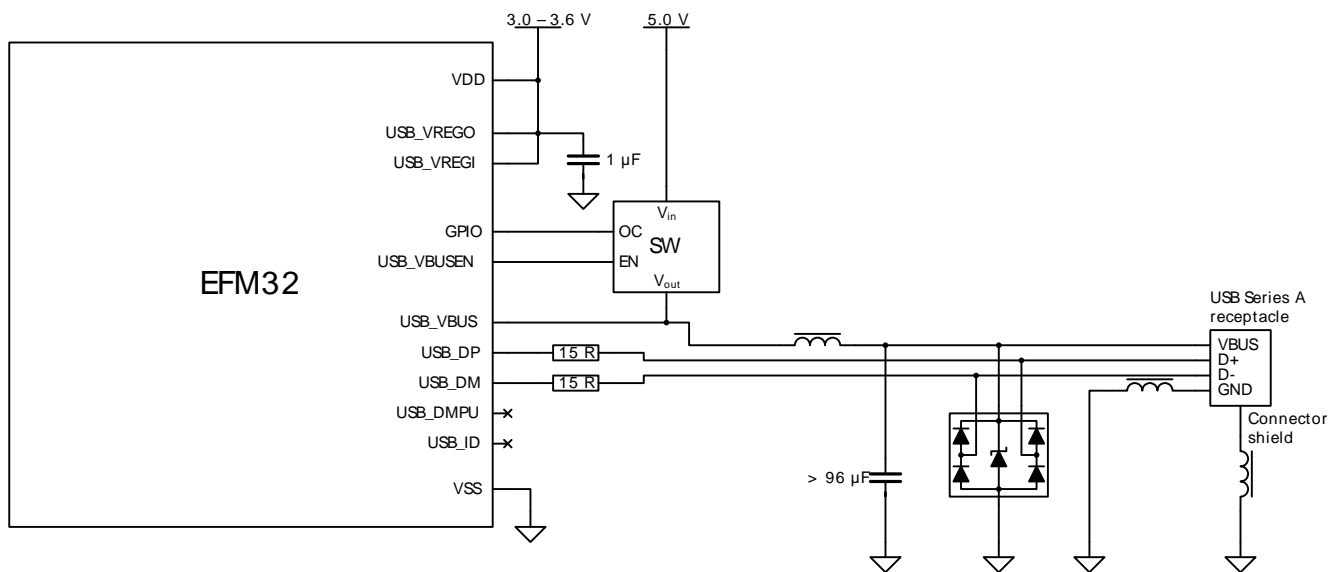

When designing hardware for USB Host, remember the following:

- Use a 48 MHz (2500 ppm) crystal.
- Use ferrite beads for VBUS, GND and receptacle shield. Place near receptacle.
- Use a switch that can shut off VBUS if current exceeds 500 mA.
- Provide at least 96 uF decoupling capacitance on VBUS. Place near USB receptacle.
- Terminate D+ and D- with 15 ohm serial resistors. Place near EFM32.
- Use an ESD protection device. Place near USB receptacle.
- Select a USB Series A type receptacle.

2.3 EFM32 as USB Device

USB devices are bus slaves that provide functionality to the USB host. Devices must provide configuration information to the host so that the host can configure the connection. Devices are separated in different classes depending on their functionality. Two different types of device classes exist; hubs and functions. Hubs provide a host with more attachment points, while functions provides additional functionality. Examples of functions are human interface devices, mass storage devices and communication devices.

USB devices will transmit data or control information over the bus when requested by the host. EFM32 microcontrollers can not operate as a USB hub device. As a USB host provides +5 V over the VBUS line, a USB device can either be powered over the USB cable, or it can be self powered. The following sections present schematics for how to connect an EFM32 as both a bus powered device and a self powered device. Please refer to the USB specifications for details on how much current can be drawn over the USB bus for different configurations.

2.3.1 Self Powered Device

Figure 2.2. USB Self Powered Device Schematics

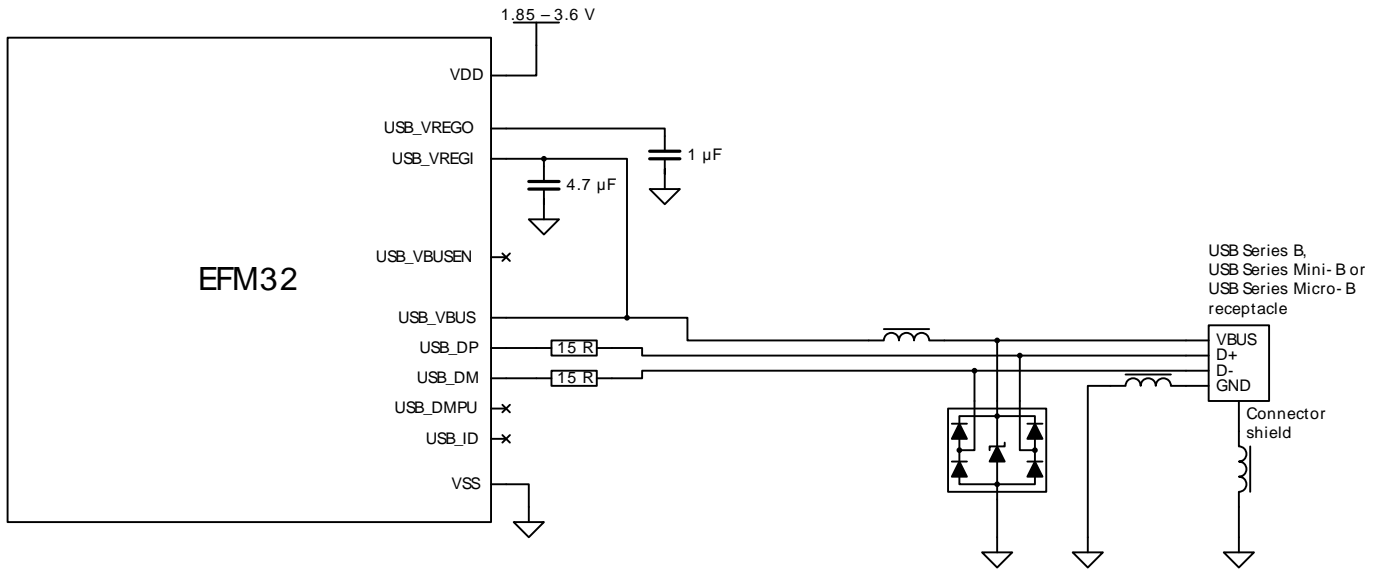

When designing hardware for a self powered USB Device, consider the following:

- Use a 48 MHz (2500 ppm) crystal.
- Use ferrite beads for VBUS, GND and receptacle shield. Place near receptacle.
- Provide at least 4.7 uF decoupling capacitance on USB_VREGI. Place near EFM32.
- Keep total load capacitance on VBUS below 10 uF
- Provide at least 1 uF decoupling capacitance on USB_VREGO. Place near EFM32.
- Terminate D+ and D- with 15 ohm serial resistors. Place near EFM32.
- Use an ESD protection device. Place near USB receptacle.

2.3.2 Bus Powered Device

Figure 2.3. USB Bus Powered Device Schematics

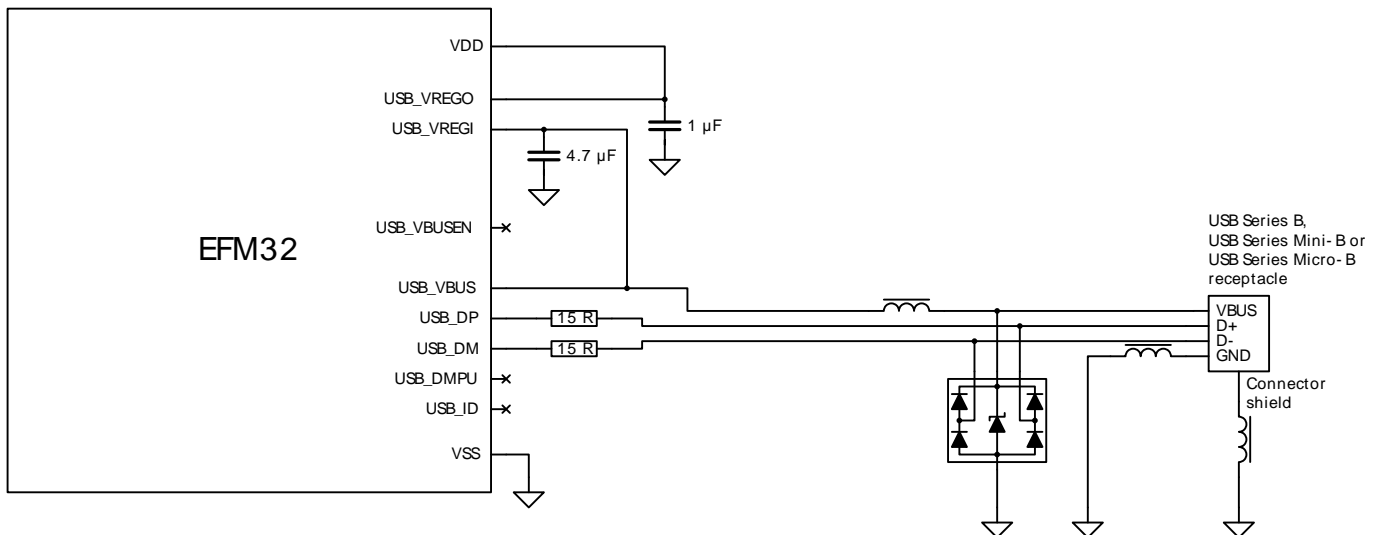

When designing hardware for a bus powered USB Device, consider the following:

- Use a 48 MHz (2500 ppm) crystal.
- Use ferrite beads for VBUS, GND and receptacle shield. Place near receptacle.
- Provide at least 4.7 uF decoupling capacitance on USB_VREGI. Place near EFM32.
- Keep total load capacitance on VBUS below 10 uF
- Provide at least 1 uF decoupling capacitance on USB_VREGO. Place near EFM32.
- Connect USB_VREGO to VDD.
- Provide decoupling capacitance on VDD as per AN0002 Hardware Design Considerations.
- Terminate D+ and D- with 15 ohm serial resistors. Place near EFM32.
- Use an ESD protection device. Place near USB receptacle.

2.3.3 Low-speed

Speed identification of USB devices is done with a pull-up on one of the data lines. A low-speed capable device is identified by a 1.5 kohm pull-up resistor on the D- line. The internal pull-up resistor on EFM32 microcontrollers is approximately 2.2 kohm, so an external 4.7 kohm resistor must be placed in parallel to be standard compliant. This resistor should be connected to the USB_DMPU pin so it can be switched on and off by the USB PHY.

Even if omitting the external pull-up resistor will most likely work, it will not be USB compliant because the internal resistor value is outside the USB specification.

It should also be noted that according to USB specification, low-speed mode is defined to support a limited number of low-bandwidth devices, such as mice. Low-speed devices are not allowed to use standard USB cables, and a separate specification for low-speed cables exist.

Figure 2.4. USB Low-speed Device Schematics

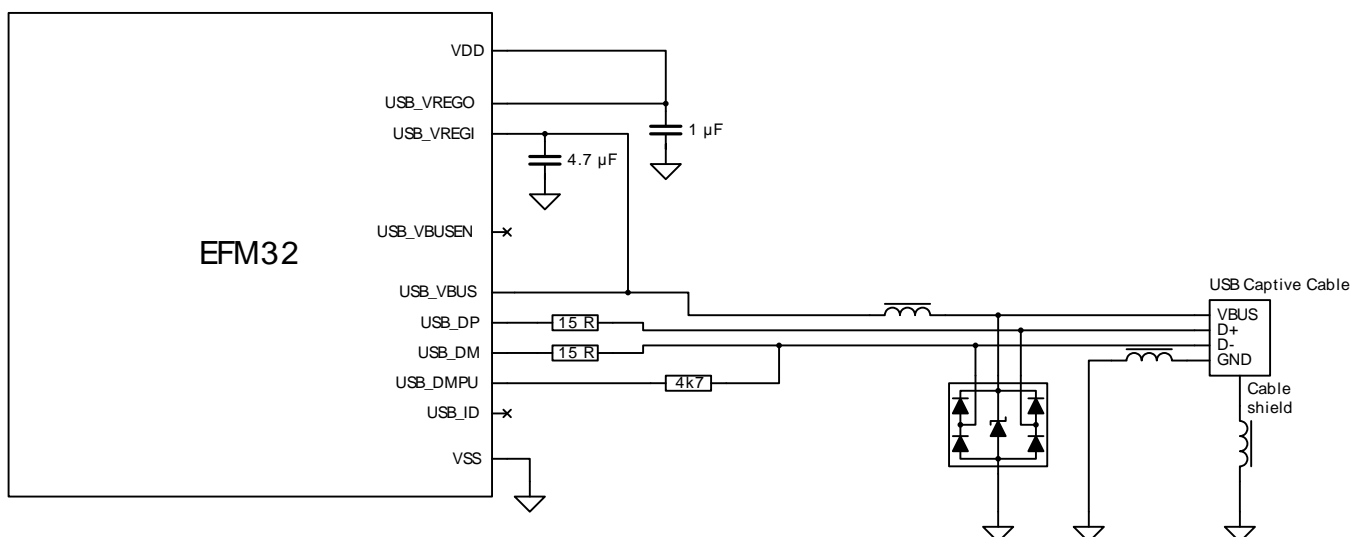

When designing hardware for a Low-speed USB Device, consider the following:

- Use a 48 MHz 2500 ppm crystal.
- Use ferrite beads for VBUS, GND and receptacle shield. Place near receptacle.
- Connect a 4.7 kohm resistor between USB_DMPU and D-
- Provide at least 4.7 uF decoupling capacitance on USB_VREGI. Place near EFM32.
- Keep total load capacitance on VBUS below 10 uF
- Provide at least 1 uF decoupling capacitance on USB_VREGO. Place near EFM32.

- Terminate D+ and D- with 15 ohm serial resistors. Place near EFM32.
- Use an ESD protection device. Place near USB receptacle or where the cable connects to the PCB.
- Do not use a standard USB receptacle.

In the above schematics, a bus powered device is shown. A low speed device may also be self powered, but if VDD is below USB_VREGO (3.3 V) the external pull-up should be connected to USB_VREGO instead of USB_DMPU and a switch should be used to turn it on or off through USB_DMPU. If this is not done, there will be a leakage current from VREGO to VDD through the pull-up.

2.4 EFM32 as USB On-The-Go Dual Role Device

On-The-Go Dual Role Device (OTG) is not yet supported in the Energy Micro USB stack, but EFM32 hardware is OTG capable.

When operating as a OTG Dual Role Device, a USB product is capable of operating both as a USB host and a USB device. A dual role capable device must use a Micro-AB receptacle which can accept both a Micro-A plug and a Micro-B plug. Two dual role devices can be connected together with a cable that has a Micro-A plug in one end and a Micro-B plug in the other end. In this case the device where the Micro-A plug is inserted will act as host and must provide +5 V on VBUS. The plug type is detected by the ID pin, which is shorted to GND on a Micro-A plug.

Figure 2.5. USB On-the-Go Dual Role Device Schematics

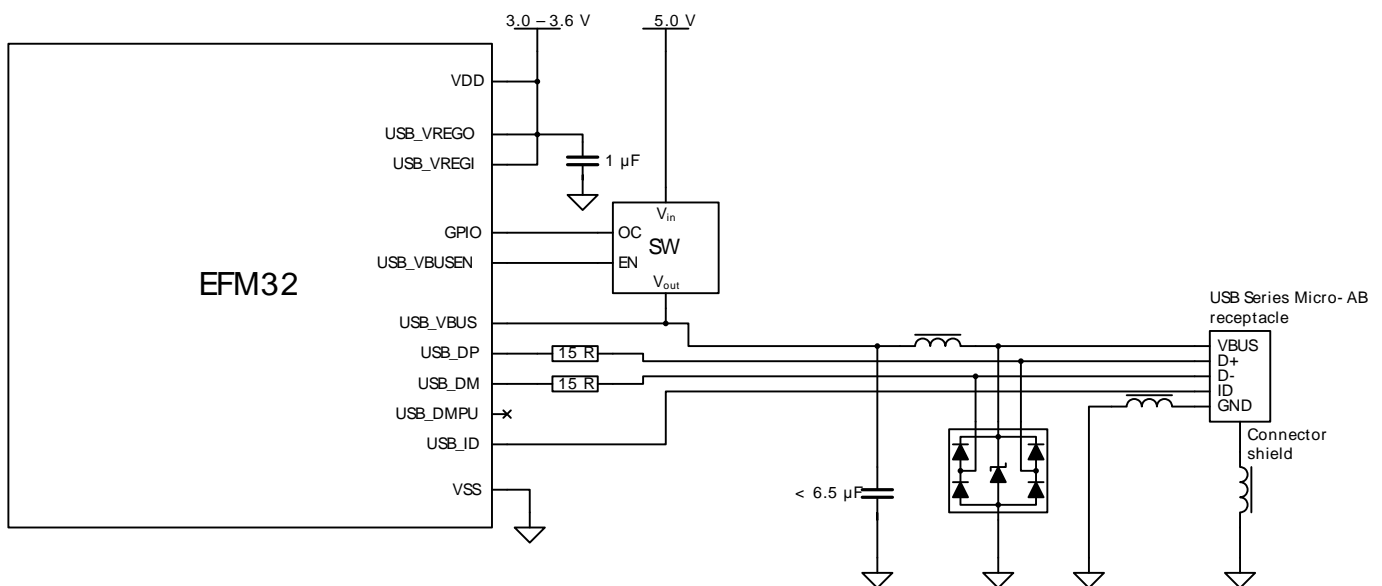

When designing hardware for an OTG Dual Role Device, consider the following:

- Use a 48 MHz 2500 ppm crystal.
- Use ferrite beads for VBUS, GND and receptacle shield. Place near receptacle.
- Connect the ID pin on the receptacle to USB_ID
- Ensure that total capacitance on VBUS is less than 6.5 uF
- Provide at least 1 uF decoupling capacitance on USB_VREGO. Place near EFM32.
- Terminate D+ and D- with 15 ohm serial resistors. Place near EFM32.
- Use an ESD protection device. Place near USB receptacle or where the cable connects to the PCB.
- Use a USB Series Micro-AB receptacle.

3 PCB Design Guidelines

This section presents some basic guidelines for high-speed PCB design as well as some specific rules of thumb for USB full-speed design.

3.1 Recommended Routing Rules of Thumb

- Route D+ and D- as 90 ohm differential pair
- Always provide a good return path (ground) for current
- Do not route over a gap in the reference plane
- Keep away from the edge of the reference plane
- Keep skew less than 400 ps
- Route D+ and D- on top layer
- Route D+ and D- as short as reasonably possible

3.2 PCB Stackup

When designing high speed signal traces on a PCB, thought must be given to the PCB stackup. The two common approaches are to either route high speed signals on an inner layer, or to keep them on the top layer. The advantage of using an inner layer is improved noise immunity and to avoid any track impedance discontinuities when routing the signal under components, connectors etc. The benefits with outer layer routing is to avoid vias which easily cause discontinuities in the return current path unless special care is taken. For USB signals on EFM32 microcontrollers the preferred solution is normally to route the signal on an outer layer, as PCB traces usually are short.

Independently of whether the signals are routed on an inner or outer layer, they should always be routed over a solid reference plane. Thus the PCB should have minimum 2 layers.

3.3 Routing

When a signal trace on a PCB is long relative to the highest frequency component of the signal, transmission line effects must be taken into consideration. The transition between when a wire should be modeled as a transmission line and a wire with "no length" is gradual, but common practice is to apply transmission line models when the trace length is more than 1/10th of the wavelength of the highest frequency component on the trace. For traces shorter than this, it is safe to assume that the voltage level is the same over the entire trace.

For digital signals the shortest wavelength is dependent on the signal bandwidth which again depends on the shortest rise and fall times. Faster rise times equals higher frequency content. A common approximation is that

$$BW \approx \frac{0.35}{t_r}$$

where t_r is the minimum rise time from 10-90%. USB specifies a minimum rise time of 4 ns, which equals a maximum signal bandwidth of 87.5 MHz or a minimum wavelength of 1.7 meters on a typical PCB trace. Thus if PCB traces are shorter than 170 mm, it can be argued that the characteristic impedance of a track is not important. However, good design practice is to route USB signals as an impedance matched differential pair according to specification.

3.3.1 Differential Pairs

The USB data lines, D- and D+, should be routed as a differential pair. The trace impedance should be matched to the USB cable differential impedance, which is nominally 90 ohms for the signal pair.

The impedance of a signal track is mainly determined by its geometry (i.e. trace width and height above the reference plane) and the dielectric constant of the material between the traces and a reference plane. When two tracks are closely spaced, they will be coupled and the differential impedance will also be dependent on the distance between the two tracks comprising the pair.

In general one can say that if the two traces of a differential pair is spaced far apart, the differential impedance will be twice the impedance of each trace. I.e. the two traces can be considered a shunt impedance. When the distance between the two traces is reduced, coupling between the traces will cause the differential impedance to decrease. Thus to create a differential pair with 90 ohms impedance, the single ended impedance of each trace should be above 45 ohms. Reducing the trace width will increase the single-ended impedance while reducing the distance between the traces in a pair reduces the impedance. This allows routing of very closely spaced differential pairs that use little PCB area. Note, however that thin traces will be more difficult to manufacture, and that for high frequencies loss due to skin effect comes into play.

Most PCB design tools support differential pairs, and can create such pairs with specified parameters. If such a tool is not available, there are many online impedance calculators that can calculate track parameters.

To avoid differential imbalance, skew (or trace length difference) between the two traces in a differential pair should be under control. A common rule of thumb is to keep the skew less than 1/10th of the fastest rise time. For USB full-speed this translates to 400 ps or 60 mm. However, this is the total skew over the entire communication link so skew in the USB cable as well as in the other communicating party must also be included. According to the USB specification the maximum allowed skew in a cable is 100 ps, which leaves a maximum of 300 ps (45 mm) of skew to be distributed amongst the host and device. Still, as you never know the characteristics of the other end, good design practice is to keep skew at a reasonable minimum.

When high speed signals are routed from one layer to another, care should also be taken to provide a path for the return signals. Remember that even differential signals use a reference plane as return path. This is particularly important when designing PCBs with many layers.

Figure 3.1. Changing layers on PCB

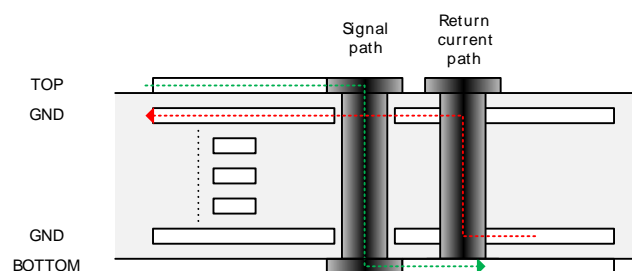

Stubs should also be avoided as they may cause signal reflections. For USB, this is seldom a problem as the data traces are point-to-point. If a test point is desired, the signal should be routed through the test point, in a fly-by manner, rather than having a long trace from the trace to the test point.

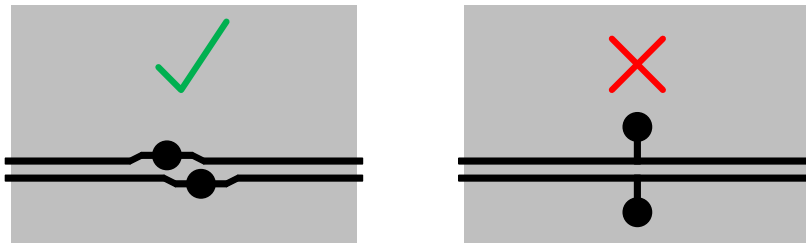
Figure 3.2. Recommended routing of test points

3.3.2 Reference Planes

Routing high speed signals across a split in the reference plane should be avoided. In high speed digital design, one always has to consider the complete current loop from a transmitter output and back to the transmitter reference terminal, including the return current in ground or another reference plane.

The path of the current from the transmitter output to the receiver is usually well defined, whereas the path of the return current often can be more complex. For low frequencies, the return impedance is dominated by resistance in the reference plane and the return current will be distributed over much of the reference plane. For higher frequencies, the inductance of the current loop will come into play, and as frequency increases the return current will start seeking a path as close to the signal trace as possible. However, if the trace crosses a split in the reference plane, the return current will be forced to follow a longer path, thereby creating a larger loop area which will both radiate more and be more susceptible to noise.

If crossing a split cannot be avoided, a good path for the high frequency return current should be provided. For instance by connecting the two planes with one capacitor (100 nF in a 0603 or smaller package could be a good size) per trace located near the high speed trace. A voltage plane can also be used as reference plane for a high speed signal as long as a proper path for the return current is provided.

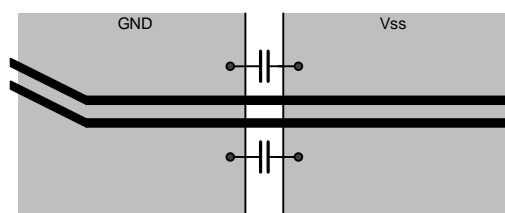
Figure 3.3. Crossing a split in the reference plane

When crossing from one plane to another, the crossing angle should be 90 degrees.

3.4 Input Impedance

Regardless of which routing strategy is chosen, care should be taken to ensure that the input impedance is within specification to avoid any reflections back on the cable.

The USB standard specifies a maximum input capacitance of 150 pF for a downstream port (i.e. host mode) and 100 pF on an upstream port (device mode).

For low-speed devices with captive cables, special requirements exist. Please refer to the USB specification for details.

To ensure a constant impedance, it is recommended to route the USB signals more than $3 \cdot H$ away from the edge of the reference plane. See figure.

Figure 3.4. Distance to edge of reference plane

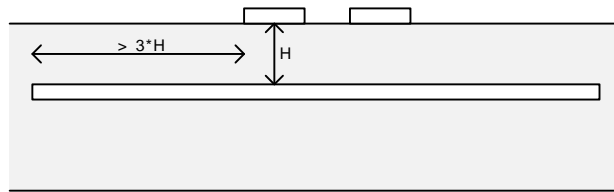

4 USB Electrical Specifications

The EFM32 USB peripheral are USB 2.0 compliant and can operate as a USB host, USB device and as an On-The-Go dual-role device. The USB 2.0 standard specifies three data rates:

- Low-speed (1.5 Mbps),
- Full-speed (12 Mbps), and
- High-speed (480 Mbps).

A USB 2.0 compliant device does not need to support all three data rates. The EFM32 supports full-speed and low-speed.

The following sections gives a brief overview of the electrical requirements on a USB interface. For extensive information, please refer to the USB specification. As EFM32 devices only support Full-speed and Low-speed data rates, this document gives most attention to these.

4.1 Signalling Levels

USB 2.0 defines two different signaling levels. There is one requirement for Full-speed and Low-speed data rates and another requirement for High-speed data rate.

Figure 4.1. USB Full-speed/low-speed Signal Levels

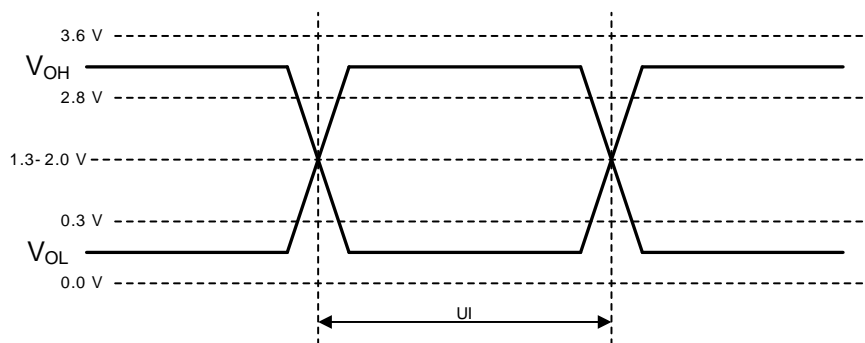

Low-speed and full-speed: V_{OD} : 0.0 - 0.3 V V_{OH} : 2.8 - 3.6 V

Low-speed: Bit period (UI) = 667 ns Full-speed: Bit period (UI) = 83 ns

4.2 Signal Rise and Fall Times

Rise and fall times are measured from 10-90% of the signal low and high levels.

Figure 4.2. USB Full-speed/low-speed Rise Time and Fall Time

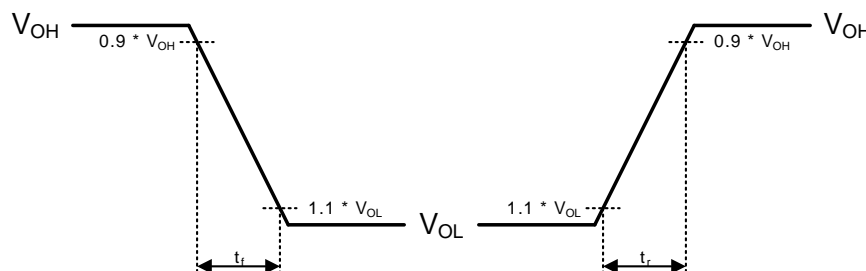

4.2.1 Full-speed

Full speed: Rise/fall time (10-90%) 4-20 ns

4.2.2 Low-speed

Low speed: Rise/fall time (10-90%) 75-300 ns.

4.3 Speed Identification

A USB device must identify its data rate capabilities to the USB host. To do this, the USB standard has set up a scheme where USB hosts have a weak pull-down resistor on both data lines, and devices have a strong pull-up resistor on one of the data lines. The size of these resistors are set to ensure that the pull-up on the device-end will pull the data line from 0 V to high (3.0-3.6 V) as seen from the host.

Nominal values for these resistors are 15 ohm for the pull-downs on the host side, and 1.5 kohm for the pull-up on the device-end.

When a device is connected to a host, the host checks which of the data lines is pulled high.

- Full-speed capable devices has the pull-up on D+
- Low-speed capable devices has the pull-up on D-

High-speed USB connections are initialized as a full-speed connection, before a negotiation sequence sets up the transition to high-speed.

4.4 USB Connectors

Several different USB connectors exist. The USB standard clearly defines which connector type are allowed for the different operating modes.

Series A receptacles are used for USB hosts and Series B receptacles are used for USB devices while Series Micro-AB receptacles are used for On-the-Go devices that are capable of acting in both host and device mode. Series Micro-AB receptacles accept both Micro-A and Micro-B connectors.

4.4.1 USB Receptacles

Figure 4.3. USB Series A Receptacle for USB Host

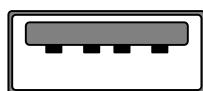

Figure 4.4. USB Series B Receptacle for USB Device

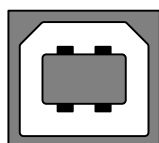

Figure 4.5. USB Series Mini-B Receptacle for USB Device. Smaller form factor.

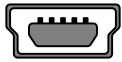

Figure 4.6. USB Series Micro-AB Receptacle for USB OTG Dual Role Devices only. Even smaller form factor.



Figure 4.7. USB Series Micro-B Receptacle for USB Device



5 Power

The EFM32 feature an on-chip 5 V to 3.3 V regulator that is used to power the internal USB PHY. This ensures that the USB signalling levels remain constant and within specification regardless of the voltage level on the rest of the device.

But as the regulator can output up to 50 mA, it can also be used to power both the rest of the EFM32 as well as external components. Please refer to the device family reference manual for more details on how to connect the regulator for different configurations.

If another 3.3 V source is available, and the internal regulator is not desirable to use, the USB PHY can be powered by applying 3.3 V to USB_VREGO. In this configuration, USB_VREGI must also be connected to 3.3 V to stabilize the regulator.

The voltage regulator can also be used even if the USB functionality is not used.

5.2 Bus Power Switch

In Figure 5.1 (p. 15) a simple switch is presented. This switch enables a self-powered device to switch from battery power to +5V when connected to a USB host. This is typically useful for extending the battery life of USB enabled devices by avoiding current consuming USB operations from draining the battery.

Figure 5.1. USB Battery Power Switch

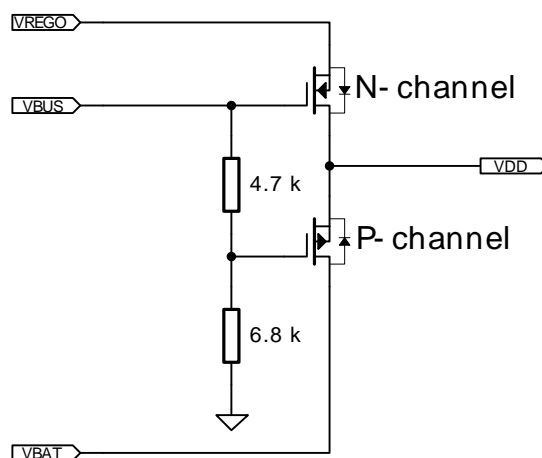

The two MOSFETs used in this circuit are an FDC6420C which contains one N-channel and one P-channel MOSFET. USB VBUS is used to control the switching transistors. When VBUS is present, the N-channel FET is switched on and the P-channel FET is switched off and vice versa. Note that the P-channel transistor is oriented with the source towards VDD to prevent applying high voltage to the battery through the body diode. The switching time can be fine tuned by changing the resistor values in the voltage divider on the transistor gates.

Note that this simple switch has certain limitations. The main being that the MOSFETs are depending on a certain voltage difference between gate and source to switch on and off, and that when switching VBUS on and off there will be a short time when both transistors are off. During this time, VDD will drop slightly until the body diode starts conducting.

The switching characteristics are also temperature dependent, so VDD will drop more for lower temperatures. The above circuit has been tested on battery voltages above 2.5 V in temperatures from 0 to 55 degrees C.

It is therefore recommended to use the above circuit as a starting point only, and always ensure that the operation will be as expected considering application specific requirements on VDD current consumption, operating temperatures and battery voltages.

6 Environmental Considerations

In this section these phenomena are discussed:

- EMI (Electromagnetic Interference); electromagnetic noise generated by an apparatus
- EMC (Electromagnetic Compatibility); an apparatus' immunity against electromagnetic noise
- ESD (Electrostatic Discharge); an apparatus' immunity against electrostatic discharges

6.1 Isolation of Cable Shield

Any cable will act as an antenna that can radiate as well as and pick up electromagnetic noise. As the USB cable shield is terminated to the USB receptacle chassis, care should be taken to decouple the USB receptacle chassis from signal ground.

To avoid problems with EMI and EMC, the USB connector should be surrounded by a solid ground plane. A ferrite bead can be used to isolate both the ground connectors of the connector and the +5 V line.

6.2 ESD Protection

The USB pins on EFM32 devices are tolerant of a 2 kV discharge according to the Human Body Model (HBM). Designers should be aware that the HBM model is only intended to model ESD events that may happen in a production environment. I.e. a device that is designed to withstand a HBM discharge will survive being handled during production.

Outside the controlled environment of a production facility, ESD events are of a different character. To account for this, a series of system level ESD tests are defined in the standard IEC61000-4-2.

Figure 6.1. Comparison of IEC 61000-4-2 and Human Body Model ESD pulses

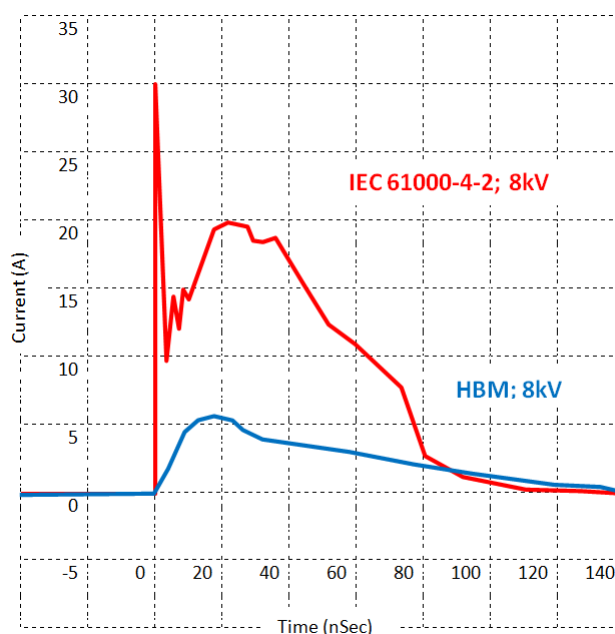

As seen in Figure 6.1 (p. 17) by Protek Devices, there is a significant difference both in the peak level and the rise-time of the test pulses between HBM and IEC 61000-4-2. A common problem is that devices whose protection are only HBM compliant can be damaged by the quick initial ESD spike before the protection circuits are activated.

To protect the EFM32 from damage from ESD discharges on the USB interface, external ESD protection must be used. On the EFM32 kits, an NXP IP4220CZ6 ESD protection device is used as shown in Figure 6.2 (p. 18). Note that this device has a maximum output voltage of 9 V, which is considerably

higher than the tolerance rating of an EFM32. However, as most of the energy of an applied ESD event will be dissipated in the ESD protection device, the residue energy is well below the levels that the EFM32 tolerates, and the total ESD protection is sufficient.

Figure 6.2. Recommended ESD Protection

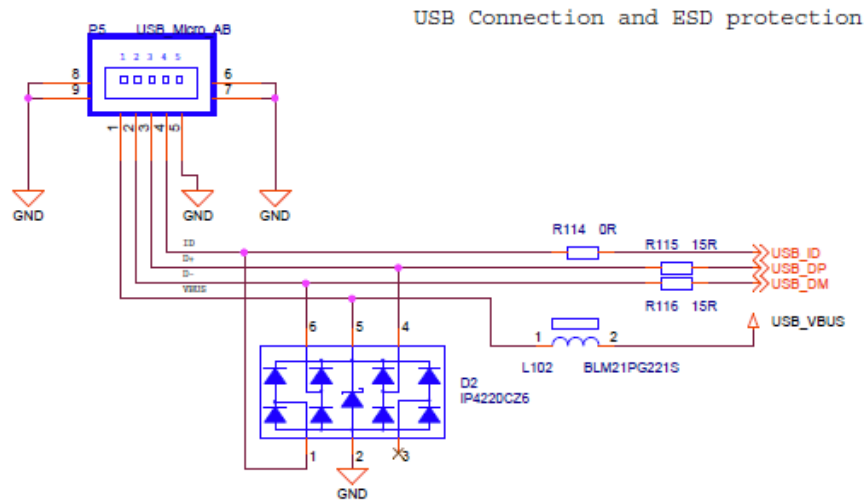

The EFM32GG-STK3700 Giant Gecko Starter Kit has been tested according to IEC 61000-4-2 and has passed an 8 kV contact discharge.

The ESD protection circuitry should be placed near the USB connector to prevent the high voltages and frequencies of an ESD event to propagate far into the PCB.

7 Further Reading

Universal Serial Bus Specification (Revision 2.0) including USB On-The-Go and Embedded Host Supplement to the USB Revision 2.0 Specification.

http://www.usb.org/developers/docs/usb_20_110512.zip

Human Body Model vs. IEC 61000-4-2 (Protek Devices)

http://www.protekdevices.com/Assets/Documents/Technical_Articles/ta1036.pdf

High Speed USB Platform Design Guidelines (Intel)

http://www.usb.org/developers/docs/hs_usb_pdg_r1_0.pdf

AN0002 Hardware Design Considerations (Energy Micro)

http://cdn.energymicro.com/dl/an/pdf/an0002_efm32_hardware_design_considerations.pdf

AN0016 Oscillator Design Considerations (Energy Micro)

http://cdn.energymicro.com/dl/an/pdf/an0016_efm32_oscillator_design_considerations.pdf

8 Revision History

8.1 Revision 1.01

2013-09-03

New cover layout

8.2 Revision 1.00

2013-01-25

Initial revision.

A Disclaimer and Trademarks

A.1 Disclaimer

Silicon Laboratories intends to provide customers with the latest, accurate, and in-depth documentation of all peripherals and modules available for system and software implementers using or intending to use the Silicon Laboratories products. Characterization data, available modules and peripherals, memory sizes and memory addresses refer to each specific device, and "Typical" parameters provided can and do vary in different applications. Application examples described herein are for illustrative purposes only. Silicon Laboratories reserves the right to make changes without further notice and limitation to product information, specifications, and descriptions herein, and does not give warranties as to the accuracy or completeness of the included information. Silicon Laboratories shall have no liability for the consequences of use of the information supplied herein. This document does not imply or express copyright licenses granted hereunder to design or fabricate any integrated circuits. The products must not be used within any Life Support System without the specific written consent of Silicon Laboratories. A "Life Support System" is any product or system intended to support or sustain life and/or health, which, if it fails, can be reasonably expected to result in significant personal injury or death. Silicon Laboratories products are generally not intended for military applications. Silicon Laboratories products shall under no circumstances be used in weapons of mass destruction including (but not limited to) nuclear, biological or chemical weapons, or missiles capable of delivering such weapons.

A.2 Trademark Information

Silicon Laboratories Inc., Silicon Laboratories, the Silicon Labs logo, Energy Micro, EFM, EFM32, EFR, logo and combinations thereof, and others are the registered trademarks or trademarks of Silicon Laboratories Inc. ARM, CORTEX, Cortex-M3 and THUMB are trademarks or registered trademarks of ARM Holdings. Keil is a registered trademark of ARM Limited. All other products or brand names mentioned herein are trademarks of their respective holders.

B Contact Information

Silicon Laboratories Inc.

400 West Cesar Chavez

Austin, TX 78701

Please visit the Silicon Labs Technical Support web page:

<http://www.silabs.com/support/pages/contacttechnicalsupport.aspx>

and register to submit a technical support request.

Table of Contents

- 1. Introduction 2
- 2. USB Connection 3
 - 2.1. EFM32 USB Pin Descriptions 3
 - 2.2. EFM32 as USB Host 3
 - 2.3. EFM32 as USB Device 4
 - 2.4. EFM32 as USB On-The-Go Dual Role Device 7
- 3. PCB Design Guidelines 8
 - 3.1. Recommended Routing Rules of Thumb 8
 - 3.2. PCB Stackup 8
 - 3.3. Routing 8
 - 3.4. Input Impedance 10
- 4. USB Electrical Specifications 12
 - 4.1. Signalling Levels 12
 - 4.2. Signal Rise and Fall Times 12
 - 4.3. Speed Identification 13
 - 4.4. USB Connectors 13
- 5. Power 15
 - 5.1. 15
 - 5.2. Bus Power Switch 15
- 6. Environmental Considerations 17
 - 6.1. Isolation of Cable Shield 17
 - 6.2. ESD Protection 17
- 7. Further Reading 19
- 8. Revision History 20
 - 8.1. Revision 1.01 20
 - 8.2. Revision 1.00 20
- A. Disclaimer and Trademarks 21
 - A.1. Disclaimer 21
 - A.2. Trademark Information 21
- B. Contact Information 22
 - B.1. 22

List of Figures

2.1. USB Host Schematics	4
2.2. USB Self Powered Device Schematics	5
2.3. USB Bus Powered Device Schematics	5
2.4. USB Low-speed Device Schematics	6
2.5. USB On-the-Go Dual Role Device Schematics	7
3.1. Changing layers on PCB	9
3.2. Recommended routing of test points	10
3.3. Crossing a split in the reference plane	10
3.4. Distance to edge of reference plane	11
4.1. USB Full-speed/low-speed Signal Levels	12
4.2. USB Full-speed/low-speed Rise Time and Fall Time	12
4.3. USB Series A Receptacle for USB Host	13
4.4. USB Series B Receptacle for USB Device	13
4.5. USB Series Mini-B Receptacle for USB Device. Smaller form factor.	14
4.6. USB Series Micro-AB Receptacle for USB OTG Dual Role Devices only. Even smaller form factor.	14
4.7. USB Series Micro-B Receptacle for USB Device	14
5.1. USB Battery Power Switch	15
6.1. Comparison of IEC 61000-4-2 and Human Body Model ESD pulses	17
6.2. Recommended ESD Protection	18

silabs.com

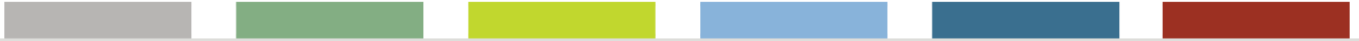

ZERO
ARM Cortex-M0+



TINY
ARM Cortex-M3



GECKO
ARM Cortex-M3



LEOPARD
ARM Cortex-M3



GIANT
ARM Cortex-M3



WONDER
ARM Cortex-M4

