

Primatech

P250F

**PNEUMATIC FLOORING TOOL
OPERATING INSTRUCTIONS**



WARNING

Read these instructions thoroughly before using this tool and keep it handy for reference.

PRIMATECH PNEUMATIC TOOL P250F

The pneumatic flooring tool P250F is a professional precision tool specially developed for the installation standard 3/4" solid hardwood flooring. It has been designed for easy maintenance where major components can be accessed within seconds without the need of any tool. Weighting only 10.3 pounds (4.7 kg), this ergonomically designed tool makes the installation of hardwood floor very easy, allowing the operator to set and fasten the boards in the standing position. It is offered in 3 different configurations:

- standard L-type 16GA nails in lengths of 1½" (38 mm), 1¾" (45 mm) or 2" (50 mm)
- T-type 16GA nails in length of 1½" (38 mm) or 2" (50 mm)
- ½" crown 15½GA staples in lengths of 1½" (38 mm), 1¾" (45 mm) or 2" (50 mm)



The P250F is built around the **Primpact** valve engine, a breakthrough technology for pneumatic tools. Primpact main features are:

- short nose and compact valve design with an all-around striking surface
- high-speed action and few moving parts, for a powerful yet soft stroke and increased precision.
- reciprocal striking system that regulates the depth of penetration independently from the mallet impact
- finely threaded screw-in module assembly

For best result, only PRIMATECH fasteners should be used. Read carefully these instructions before operating this tool. It is important to understand warnings/cautions and the safety measures to ensure safe use of this tool.

Additional information is available directly from the manufacturer:



1135 Jérémie-Fortin, Québec, QC
Canada, G1J 1R8

Phone: 1 (800) 363-1962 or 1 (418) 522-7744
Fax: 1 (418) 522-7466
email: support@primatech.ca
web: <http://support.primatech.ca>

SAFETY MEASURES

These important guidelines should always be followed to work safely with the PRIMATECH pneumatic tool model P250F:

- Read these instructions thoroughly before using this tool and keep it handy for reference if necessary.
- Always keep hands, feet or other body parts away from the fastener ejection area.
- Never aim the tool in any direction other than the working area.
- Always carry or manipulate the tool by its handle while the air supply hose is connected.
- Never hit the head cap of the actuator if the plastic base is not sitting perfectly on the working surface.
- Never leave the tool laying down on its side while the air supply hose is connected; the tool should always be left on the floor, standing on its plastic base.
- Do not alter or remove safety.
- Always disconnect the air supply hose when the tool is not in use or when move to another work area.
- Never service or repair the tool, clear obstructions or make adjustments while the air supply hose is connected.
- Only compressed air should be used to power this tool; do not exceed 110 psi (7.6 bar).
- Never use oxygen or any other compressed gas as a power source for this tool. Explosion may occur.
- Always wear OSHA-required Z-87 safety glasses with side shields.
- Always wear proper ear and foot protection while the air supply hose is connected.
- Always remove fasteners from the magazine before servicing tool.



DO NOT REMOVE OR ALTER SAFETY. DO NOT USE A TOOL WITH A DEFECTIVE SAFETY. NEVER DEPRESS THE SAFETY CONTACT WITH YOUR HANDS WHEN TOOL IS CONNECTED TO AIR SUPPLY. EXTREME CAUTION IS ADVISED WHEN USING THIS TOOL.

Eye protection is recommended and should be worn by the operator and other in working area. Accidental ejection of fasteners or wood debris could cause severe eye injury.



In some environments, ear protection might be required, as working condition may include exposure to high noise levels which lead to hearing damage.



Wearing safety boots and safety hat is also highly recommended.



NOTE: All the personal protection equipments must meet national standards.



CONNECTION & AIR SUPPLY SYSTEM

To ensure maximum performance and efficiency, and also a minimum of care, this tool requires clean & dry air. The use of a filter and a pressure regulator is recommended.

This tool needs a detachable male coupler with 3/8" NPT male threads. The use of a 3/8" (1 cm) diameter air supply hose is recommended. A smaller hose or a hose longer than 50' (15 m) could cause a pressure drop when the tool is activated repeatedly.



ALWAYS USE A FREE-FLOW CONNECTION FOR THE COMPRESSED AIR SUPPLY TO PREVENT THAT THE TOOL STAYS CHARGED AFTER DISCONNECTING THE AIR SUPPLY HOSE.



UNLOAD TOOL BEFORE CONNECTING AIR TO PREVENT ACCIDENTAL DISCHARGE.



AFTER MOVING TOOL TO A DIFFERENT WORK AREA, OR AFTER ANY MAINTENANCE TO THE TOOL, ALWAYS ENSURE PROPER OPERATION BY ACTUATING TOOL SEVERAL TIMES WITHOUT FASTENERS OVER THE SUBFLOORING .

Dirt, dust, and other particles in the air supply can cause sluggish operation or premature wear of many components of the tool. Drain water from the compressor tank regularly. The compressor start-stop limits should be set to deliver an air pressure of at least 100 psi (7 bar) at all times. Consult the compressor manual or dealer for instructions on how to make this adjustment.

At 80 psi (5.5 bar) and 40 hits per minute, this tool consumes approximately 1.9 cu.ft (50 l) of air per minute at 70EF (21EC). Higher air pressure will increase the consumption of compressed air.

This tool is designed to be operated with a compressed air pressure of 80 to 100 psi (5.5-7.0 bar). Air pressure of 90 psi (6.2 bar) is adequate for most situations, although occasionally, a higher pressure could be necessary. Always use the tools at minimum operating pressure in order to avoid unnecessary high noise level. In these more difficult cases, the compressed air pressure can be increased up to 100 psi (7.0 bar). It is very important not to exceed this maximum pressure to prevent leaks, premature wear or damages to the tool.

Check the compressed air supply hose before connecting to ensure that it is free from dirt or particles that can alter the performance of the tool. Pay special attention to any air leaks. Do not use a compressed air pressure higher than 110 psi (7.6 bar). Higher pressure can cause premature wear or damage to certain components. After assembly, check all the connections to prevent the leaks and to have maximum efficiency.



TO PREVENT ACCIDENTAL DAMAGE TO THE FINISHED SURFACE OF THE INSTALLED FLOOR, REST THE TOOL ONTO THE SUBFLOORING WHEN CONNECTING AIR, LOADING TOOL OR PERFORMING ANY MAINTENANCE TO THE TOOL.

LOADING THE TOOL

This tool comes in one of 3 different configurations:

- L-type 16ga nails in lengths of 1½" (38 mm), 1¾" (45 mm) or 2" (50 mm)
- T-type 16ga nails in lengths of 1½" (38 mm) or 2" (50 mm)
- ½" crown 15½ga staples in lengths of 1½" (38 mm), 1¾" (45 mm) or 2" (50 mm)



USE ONLY THE TYPE OF FASTENERS IDENTIFIED ON THE MAGAZINE. THE USE OF ANY OTHER TYPE OF FASTENERS WILL DAMAGE THE TOOL.

P250FL – Loading the tool with L-type 16ga nails:

This tool is fitted with the **LOADXTEND** technology. Its automatic magazine holds & feeds 200 nails (2 strips) in an assembly no longer than a conventional one. Its exclusive pusher locks into a pre-armed position, allowing nails to be fed by gravity until it automatically engages behind. To load the tool:

- Insert one or two rows of flooring nails into the back end of the magazine.
- Pull the pusher back completely and release it until it locks in position or engages behind the nails.
- To remove nails from the magazine, simply squeeze the pusher with your thumb and index finger and allow it to recoil slowly. You can then slide out remaining nails.

P250FT – Loading the tool with T-type nails:

- Insert a row of T-type nails into the back end of the magazine.
- Pull back on the pusher until it engages behind the nails.
- To remove nails from the magazine, simply squeeze the pusher with your thumb and index finger and allow it to recoil slowly. You can then slide out remaining nails.

P250FS – Loading the tool with flooring staples:

This tool is fitted with the **LOADXTEND** technology. Its automatic magazine hold & feed 4 strips of flooring staples in an assembly no longer than a conventional one. Its exclusive pusher locks into a pre-armed position, allowing staples to be fed by gravity until it automatically engages behind. To load the tool:

- Insert up to 4 strips of flooring staples into the back of the magazine.
- Pull the pusher back completely and release it until it locks in position or engages behind the last strip.
- To remove staples from the magazine, pull back completely and hold the pusher, tilt the tool to slide back remaining staples.

OPERATION

Unload tool and rest it onto the subflooring. Connect the hose and cycle tool once or twice without fastener. After loading the tool, the tool is ready for use.

Use only the 2.5 lbs (1.1 kg) hammer supplied with the tool. The use of other type of hammers may affect performance. The rubber face of the hammer can be used with care to help position the boards.

With the flooring firmly in place, position the tool onto the flooring and apply downward pressure to ensure proper seating of the fastener. Strike the head cap with the hammer to activate the tool. **Use only the RUBBER FACE of the hammer to activate the tool. Using the steel end will damage the tool and void the warranty.** If wood is slightly twisted, hitting the tool with more force will assist in pulling the board up snugly. **NEVER** strike the head cap when the tool is not sitting on the working surface.



OPERATING THE TOOL WHEN THE SAFETY CONTACT IS NOT FULLY DEPRESSED WILL CAUSE PREMATURE WEAR OR DAMAGE TO THE DRIVING BLADE, PISTON AND CYLINDER.

Be it raw, factory finished or engineered, hardwood is a natural material subject to various factors, such as humidity, subflooring, installation procedure, type of tools, fasteners, *etc.* Installer should always ensure optimal surface preparation, comply with all manufacturers recommendations and conduct a pre-installation test prior to beginning any installation.



BEFORE STARTING AN INSTALLATION, FASTEN DOWN FEW BOARDS TO ASCERTAIN THAT YOU ARE USING THE RIGHT FASTENER AND THAT THE TOOL IS PROPERLY ADJUSTED.

MAINTENANCE & REPAIR

Most adjustments to the tool can be made with the 3/16" Allen wrench supplied with the tool.

Disassembly of the tool must be done in a clean environment. Some parts can be easily damaged if disassembled with improper tools or by inadequate methods. Maintenance should only be performed by trained personnel. Use only genuine PRIMATECH replacement parts.



TO PREVENT INJURY, ALWAYS DISCONNECT THE AIR SUPPLY HOSE WHEN SERVICING OR DISASSEMBLING THE TOOL.

When servicing the tool, do not twist or force any parts. Damage may result from such abuse. Contact your PRIMATECH distributor for more information.

When opening the tool for maintenance, always clean all components of dirt, grit, or particles. Inspect the tool carefully for broken parts or excessive wear, and replace if necessary. When ordering parts, be sure to specify the right part number, as well as the tool serial number.



AFTER ANY MAINTENANCE TO THE TOOL, REMOVE ALL FASTENERS BEFORE CONNECTING AIR AND ACTUATE THE TOOL REPEATEDLY OVER A PIECE OF WOOD OR SUBFLOORING TO INSURE PROPER OPERATION.

DISASSEMBLING THE TOOL

All pneumatic components required are packed in a module assembly which is simply inserted & removed from the tool. This section describes how to disassemble the tool to access its internal components.

- [1] Loosen up the head lock and rotate it $\frac{1}{4}$ turn to disengage it from the head.
- [2] It is usually not necessary to remove the head cap. Simply unscrew the head completely and take out the whole assembly. You may engage the long arm of the Allen key into one of the side holes and use it as a lever.
- [3] Pull out by hand the cylinder from the head. Do not use screwdriver or vise. If the cylinder remains into the main body, pull it out of it.
- [4] Pull out the valve assembly from the head. Inspect wear ring & lubricate. Do not attempt to disassemble the valve assembly.
- [5] Pull out the piston assembly; the bumper will also come with it. Inspect wear ring and lubricate.

It is usually not necessary to pull-out the seal bushing for maintenance.

PREVENTIVE MAINTENANCE

This tool requires minimal lubrication. Use only detergent-free oil such as Primatech P-090. Few drops of oil weekly in the air inlet is sufficient. Other types of lubricant may degrade the seals.



Check periodically to make sure that the head assembly is fully screwed onto the main body. A loosen head will damage the threads.

CLEANING THE VALVE

If the tool becomes sluggish or does not set the fastener correctly, it may indicate excessive dirt, dust, other particles, or even water, in the tool. The first step in troubleshooting is to clean up the head assembly.

- Disassemble the head assembly as described in previous section.
- Perform a visual inspection of the valve assembly. Ensure that the actuator is sliding easily. Clean and lubricate lightly. Do not attempt to take apart the actuator assembly.
- Clean the inside wall of the head and lubricate lightly with a non-detergent oil. Insert the valve assembly into the head and ensure that it is sliding easily.
- Ensure the piston assembly is sliding easily into the cylinder. It should offer some resistance, but if it moves too easily, it may be required to replace the piston wear-ring.

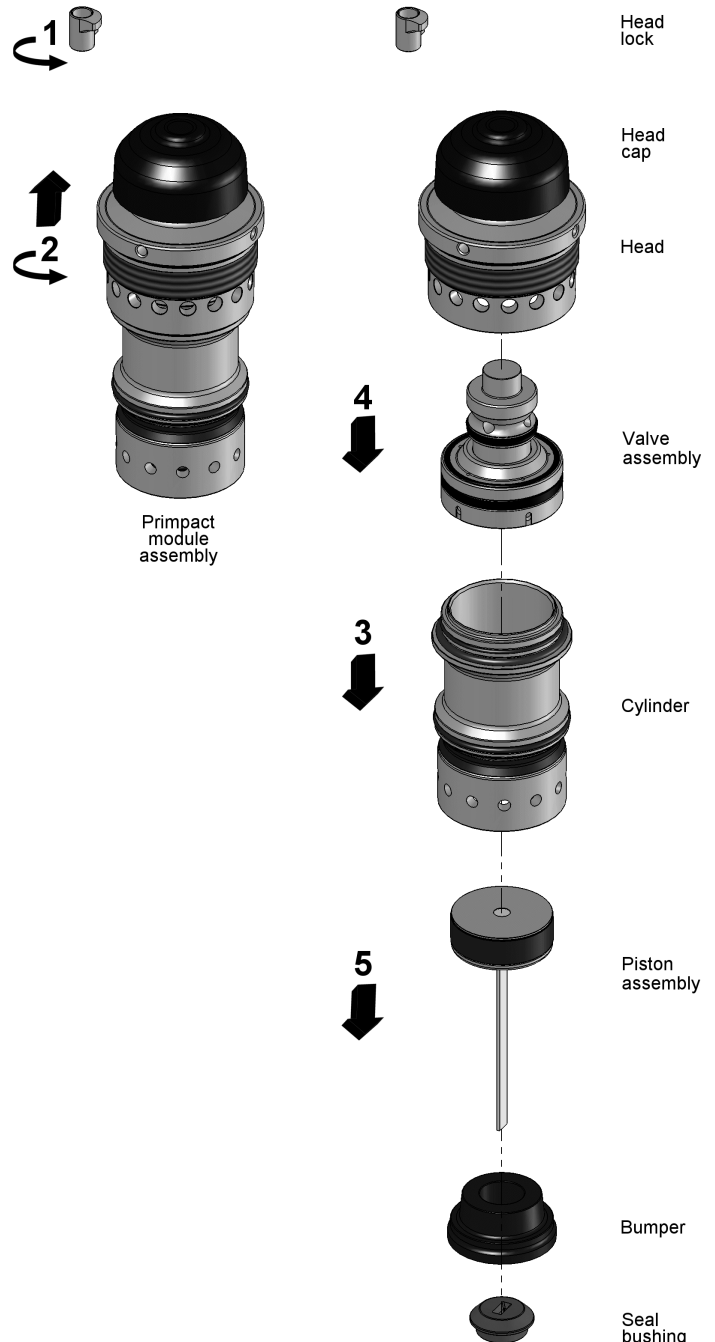

ASSEMBLING THE TOOL

This section describes how to re-assemble the tool after maintenance. The following procedure assumes that the gate/foot assembly along with the resting block are already installed.

- [1] Insert the seal bushing in the lower section of main body and engage it onto the upper portion of the gate/foot assembly. A flat screwdriver can help locate it correctly. Use the wooden handle of the hammer to tap the seal bushing completely in place.

Note: select the appropriate replacement part:

- use P-525B for the "L" or "T" nailers
- use P-525C for staplers

- [2] With the tool in the upright position, push the bumper in place, indexed onto the seal bushing.
- [3] Insert the piston assembly into the tool and engage the driving blade thru the opening of the seal bushing. Depress the safety contact and engage down the driving blade has completely into gate/foot assembly guiding channel.
- [4] Check & lubricate the valve assembly. Insert into the head and ensure that it is sliding easily.
- [5] Snap the cylinder onto the head. Check that the band-valve on the cylinder is properly installed.
- [6] With the head lock loosened, insert the whole module assembly into the main body; the main cylinder engaging onto the piston assembly. Insert the Allen key into one of the side holes and screw the head assembly completely. Take care not do damage the threads. Tighten by hand.



NEVER APPLY THREADLOCKER OR ADHESIVE ONTO HEAD THREADS.

- [7] Rotate the head lock clockwise and tighten with moderate force with the Allen key.



AFTER REASSEMBLY, ALWAYS ACTUATE THE TOOL REPEATEDLY WITHOUT FASTENERS AGAINST A PIECE OF WOOD TO INSURE PROPER OPERATION.

This tool features a head lock to maintain firmly in place the head assembly during operation. Before inserting the head assembly, ensure that the lock is free to swivel and rotate it away from the head opening. After inserting the head assembly in place, rotate the lock and tighten with the Allen key using moderate force. To remove the head assembly, simply unscrew the head lock ¼ turn and rotate it counter-clockwise.

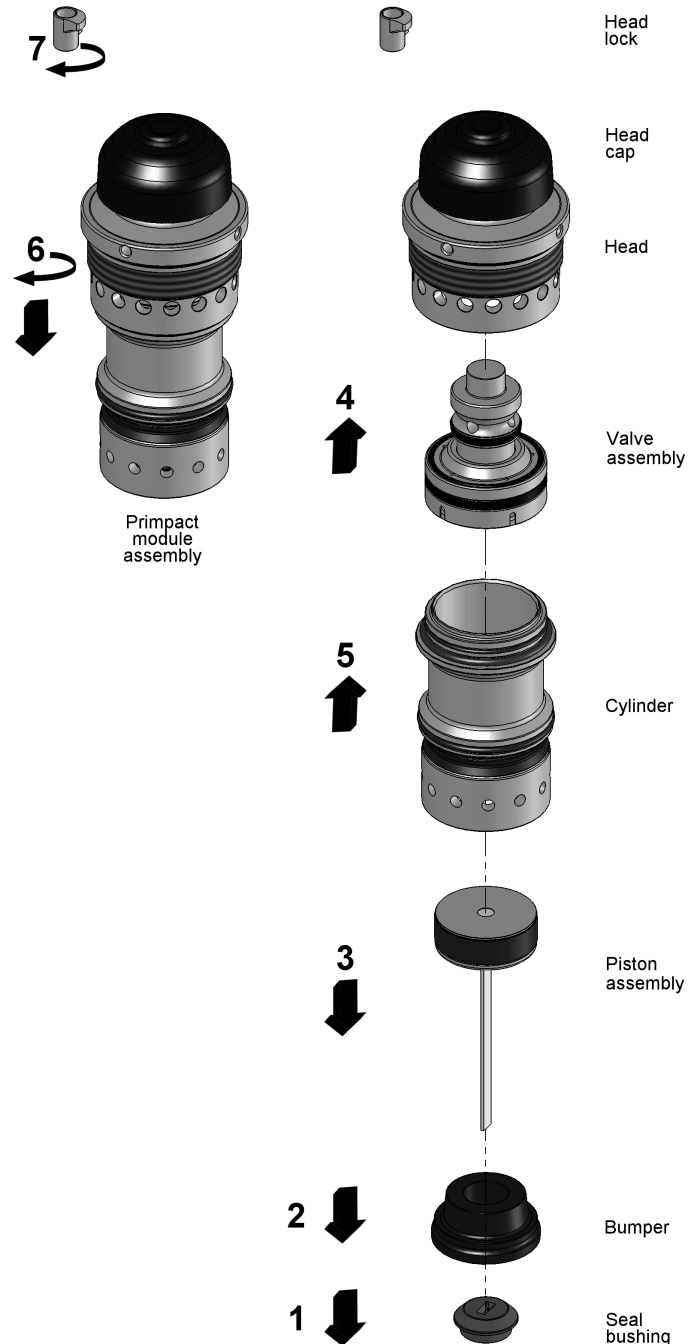
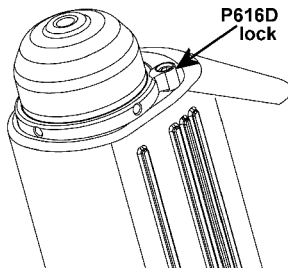

REPLACING THE DRIVING BLADE

The driving blade is sold separately or supplied as a complete subassembly with the piston.

- Follow steps [1] & [2] of the section 'Disassembling the tool' to remove the head assembly. Pull the cylinder out of the main body if necessary. It is usually not necessary to disassemble the head assembly.
 - Pull-out the piston assembly.
 - Remove any debris and assess condition of cylinder. If marked or gouged, use a fine sand paper to smooth out walls. The piston must be allowed to move without restriction.
 - Lock the piston in a vise, using a rag to prevent scoring. Always use the top and bottom faces to secure the piston in place.
 - Remove the broken driver using a 1/2" closed-end wrench.
 - Put one drop of medium strength adhesive sealant onto the threads of the piston.
-
- Insert the P-622C lock washer and screw the new driving blade onto the piston. Tighten very hard (140 lb/in minimum). Make sure that the lock washer P-622C is completely flattened.

Note: select the appropriate driving blade:

- use P-423 driving blade for the "L" or "T" nailers
 - use P-237 driving blade for staplers
-
- Remove the bumper, inspect & remove debris.
 - Reassemble tool following instructions in previous section.

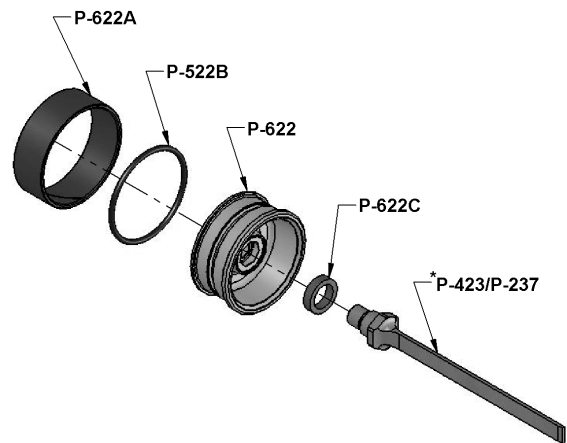

TROUBLESHOOTING PRIMACT PNEUMATIC NAILERS/STAPLERS

This technical note will help to diagnose common problems and will give suggestions to solve them. Consult our on-line Technical Support site at support.primatech.ca for updated documents and more tips.



TO PREVENT INJURY, ALWAYS DISCONNECT THE AIR SUPPLY HOSE WHEN ADJUSTING, SERVICING OR DISASSEMBLING THE TOOL.

FIRST: CHECK THE COMPRESSED AIR SUPPLY

Many of problems come from a faulty or inadequate compressed air supply system. Before attempting to repair the tool, the following points should be checked:

- Check the pressure at the output of the compressor; adjust to 80-100 psi (5.5-7.0 bar) as required.
- Check the tank pressure of the compressor & adjust the start/stop limits.
- Check the air delivery system; a 3/8" hose is recommended.
- Use fewer tools simultaneously; do not exceed the capacity of the compressor or of the delivery system.
- Drain water from the compressor.

SECOND: CHECK FOR AIR LEAKS

At rest, this tool should not have any air leaks. Before attempting to repair the tool and replace parts, check the following:

- Check all seals in head, valve and cylinder assemblies; replace if necessary.
- Check the top edge of main cylinder for burrs or dents.
- Clean & lubricate the head and valve assemblies; re-assemble the head assembly carefully.
- Check the interior of the head for scratches.

TOOL DOES NOT DRIVE FASTENERS

- Check for fasteners in the feeder channel.
- Check that the proper type of fasteners is used; 16GA & 18GA nails are not interchangeable.
- Make sure the feeder clip is engaged behind the fasteners.
- Check the front end of the feeder channel for burrs or damages.
- Check the safety mechanism.
- Check if the driver is stuck in down position.
- Check for obstruction in the fastener ejection area.

TOOL DOES NOT ACTIVATE

- Check air supply.
- Inspect the head assembly and check all seals; reassemble carefully.

HEAD ASSEMBLY LOOSENS UP DURING OPERATION P250 & Q550 PRIMACT tools only

- Loosen (¼ turn) the head lock to disengage it from the head..
- Fully screw it in place the head assembly using moderate force.
- Lock in place with the head lock.
- Check regularly that the head is always fully screwed.

FASTENERS ARE NOT SET COMPLETELY

- First, check air supply (see first note).
- Clean and lubricate tool; particularly the head assembly.
- Increase air pressure when working with harder woods; do not exceed 110 psi (7.6 bar).
- Check the driving blade for broken end.
- Check piston wear-ring; replace if piston is sliding too easily.
- Check seal bushing.
- Check the adjustment of the base and ensure the tool is well seated on the floor while ejecting.

DRIVING BLADE DOES NOT RETURN

- Check for jammed fastener or obstruction.
- Check gate/foot and end of feeder channel for damages or burrs..
- Check the driving blade.
- Inspect the head assembly and check all seals; clean & lubricate..
- Check band-valve on cylinder.
- Check that the bumper and seal bushing are in place; severe damages will occur if missing.

BROKEN OR WORN DRIVING BLADE

Replace the driving blade ; failure to follow the instructions carefully will result in repeated breakage of the driving blade.

OTHER PROBLEMS

Contact technical support
by phone

1 (800) 363-1962
1 (418) 522-7744

by email
on-line

support@primatech.ca
<http://support.primatech.ca>



TOOL WARRANTY AND LIMITATIONS

Primatech warrants that newly purchased fastening tools, parts and accessories will be free from defects in material and workmanship (excluding wear parts) for the period shown below, after the date of purchase by the original user as evidenced by a valid purchase invoice.

ONE-YEAR LIMITED WARRANTY will apply to all parts, except those subjected to normal wear

SEVEN-YEAR EXTENDED LIMITED WARRANTY covers tool casing.

WARRANTY STATEMENT

Primatech 's sole liability hereunder will be to replace any part or accessory which proves to be defective within the specific time period. Any replacement part or accessories provided in accordance with this warranty will carry a warranty for the remainder of the period of warranty applicable to the part it replaces. When repair or replacement of part or tool is required, the complete tool or part(s) must be returned to Primatech or at such authorized warranty service point of Primatech, transportation prepaid, with a copy of proof of purchase evidencing that the part or tool is within the warranty period. Serial # must be intact and legible for warranty to apply.

This warranty is void as to any tool which has been subjected to misuse, abuse, accidental or intentional damage, used with fasteners not meeting Primatech specifications, size or quality, improperly maintained, repaired with other than genuine Primatech replacement parts, damaged in transit or handling, or which, in Primatech 's sole opinion, has been altered, modified or repaired in a way that affects or detracts from the performance of the tool.

PRIMATECH MAKES NO WARRANTY, EXPRESSED OR IMPLIED, RELATING TO MERCHANTABILITY, FITNESS, OR OTHERWISE, EXCEPT AS STATED ABOVE, and Primatech's liability AS STATED ABOVE AND AS ASSUMED ABOVE is in lieu of all other warranties arising out of, or in connection with, the use and performance of the tool, except to the extent otherwise provided for by applicable law.

PRIMATECH SHALL IN NO EVENT BE LIABLE FOR ANY DIRECT, INDIRECT, OR CONSEQUENTIAL DAMAGES WHICH MAY ARISE FROM LOSS OF ANTICIPATED PROFITS OR PRODUCTION, SPOILAGE OF MATERIALS, INCREASED COST OF OPERATION, OR OTHERWISE. Any liability, if any, connected with the use of the tool shall terminate upon the expiration of the warranty period specified above.