

**ENGINE**

Model	Yanmar 4TNV88-C-PYB Tier 4 Final Certified
Cylinders	4
Bore/Stroke	3.46 x 3.54 in (88 x 90 mm)
Displacement	133.6 in <sup>3</sup> (2.2 L)
Fuel injection	Direct
Fuel	Diesel
Fuel filter	Full flow, paper element
Cooling	Liquid
Net horsepower @ 2400 RPM – SAE J1349:	37.4 hp (27.9 kW)
Net max. torque @ 1440 RPM:	97.2 lb-ft (131.8 N·m)

**DRIVETRAIN**

Travel speeds:	Forward/Reverse
Low	1.4 mph (2.2 kph)
High	2.5 mph (4.0 kph)
Gradeability	58% (30°)
Drawbar pull	12,342 lb (54.9 kN)

**ELECTRICAL**

Voltage	12 Volts – Negative ground
Alternator rating	55 amp
Battery	1 x 12 Volt – Low-maintenance

**OPERATOR ENVIRONMENT**

ROPS/FOPS four post canopy; Pilot operated hand controls and foot pedals; Adjustable seat with seat belt; Two-piece floor mat; Fold-open/-up front window – cab; Arm rests.

Display:  
Engine oil pressure; Water temperature lamp;  
Air filter lamp; Water separator detection lamp;  
Low fuel warning lamp; Battery charge lamp;  
Glow plug indicator lamp; Water temperature gauge; Fuel gauge and hour meter.

**OPERATING WEIGHT**

Cab with 165 lb (75 kg) operator, 247 lb (112 kg) bucket, full fuel and standard equipment:  
11,312 lb (5 130 kg)

**HYDRAULICS**

Pumps Tandem variable displacement axial piston pump

Capacity:  
Max. flow 2 x 13.2 gpm  
(2 x 49.9 L/min)

Auxiliary Flow 13.2 gpm (49.9 L/min)

System relief pressure:  
Standard 3,336 psi (230.0 bar)

Pilot control hydraulic system:  
Pump 1 x gear pump  
Max. capacity 4.0 gpm (15.2 L/min)  
Relief pressure 514 psi (35.4 bar)

Control valves 11-spool  
Pilot control for left/right track travel, boom, arm, bucket and swing  
Manual control for breaker and backfill blade

Swing/Dozer blade motor:  
Fixed displacement axial piston design

Travel:  
Motor 2 x 2-speed axial piston design  
Final drive Planetary gear reduction

Boom cylinder One (1)  
Bore diameter 3.94 in (100 mm)  
Rod diameter 2.17 in (55 mm)  
Stroke 27.52 in (699 mm)

Arm cylinder One (1)  
Bore diameter 3.54 in (90 mm)  
Rod diameter 1.97 in (50 mm)  
Stroke 28.19 in (716 mm)

Bucket cylinder One (1)  
Bore diameter 2.95 in (75 mm)  
Rod diameter 1.57 in (40 mm)  
Stroke 21.50 in (546 mm)

**SERVICE CAPACITY**

Fuel tank	19.8 gal (75 L)
Hydraulic tank:	
Refill capacity	7.4 gal (27.9 L)
Total system	15.2 gal (57.7 L)
Engine oil w/ filter change	2.0 gal (7.4 L)
Radiator	1.6 gal (6.0 L)

**OTHER SPECIFICATIONS**

Swing/Dozer blade speed	0 – 8.5 RPM
Swing/Dozer blade brake	Hydraulic brake
Boom:	
Swing	70° left/59° right
Length	10 ft 2 in (3.10 m)
Arm:	
Length	5 ft 6 in (1.69 m)
Number of rollers:	
Top	1 per side
Bottom	5 per side
Dozer blade travel:	Up/Down
	14.8 in/15.2 in (375 mm/385 mm)

# LIFT CAPACITIES

**Canopy Model — 5 ft 6 in (1.69 m) Arm** Lift capacities using 15.7 in (400 mm) shoes, 551 lb (250 kg) counterweight and 247 lb (112 kg) bucket, blade down.

Load (Lift Point Height)	5 ft (1.5 m)		7.5 ft (2.3 m)		10 ft (3.0 m)		12.5 ft (3.8 m)		15 ft (4.6 m)		17.5 ft (5.3 m)		MAXIMUM REACH		
	END	SIDE	END	SIDE	END	SIDE	END	SIDE	END	SIDE	END	SIDE	Radius	END	SIDE
+15 ft (4.6 m)							1,740 lb* (780 kg)*	1,740 lb* (780 kg)*					13 ft 5 in (4.11 m)	1,880 lb* (850 kg)*	1,870 lb (840 kg)
+12.5 ft (3.8 m)							1,660 lb* (750 kg)*	1,660 lb* (750 kg)*	1,840 lb* (830 kg)*	1,560 lb (700 kg)			15 ft 7 in (4.76 m)	1,740 lb (780 kg)	1,440 lb (650 kg)
+10 ft (3.0 m)							1,860 lb* (840 kg)*	1,860 lb* (840 kg)*	1,860 lb (840 kg)	1,550 lb (700 kg)			16 ft 11 in (5.17 m)	1,480 lb (670 kg)	1,230 lb (550 kg)
+7.5 ft (2.3 m)					2,640 lb* (1 190 kg)*	2,640 lb* (1 190 kg)*	2,280 lb* (1 030 kg)*	2,050 lb (920 kg)	1,820 lb (820 kg)	1,510 lb (680 kg)	1,390 lb (630 kg)	1,140 lb (510 kg)	17 ft 9 in (5.43 m)	1,340 lb (600 kg)	1,110 lb (500 kg)
+5 ft (1.5 m)			4,920 lb* (2 230 kg)*	4,280 lb (1 940 kg)	3,420 lb (1 550 kg)	2,760 lb (1 250 kg)	2,380 lb (1 070 kg)	1,950 lb (880 kg)	1,770 lb (800 kg)	1,450 lb (650 kg)	1,360 lb (610 kg)	1,120 lb (500 kg)	18 ft 2 in (5.54 m)	1,270 lb (570 kg)	1,040 lb (470 kg)
+2.5 ft (0.8 m)			2,900 lb* (1 310 kg)*	2,900 lb* (1 310 kg)*	3,230 lb (1 460 kg)	2,590 lb (1 170 kg)	2,280 lb (1 030 kg)	1,860 lb (840 kg)	1,710 lb (770 kg)	1,400 lb (630 kg)	1,330 lb (600 kg)	1,090 lb (490 kg)	18 ft 1 in (5.53 m)	1,260 lb (570 kg)	1,030 lb (460 kg)
Groundline			4,010 lb* (1 810 kg)*	3,940 lb (1 780 kg)	3,140 lb (1 420 kg)	2,500 lb (1 130 kg)	2,210 lb (1 000 kg)	1 790 lb (810 kg)	1,670 lb (750 kg)	1,360 lb (610 kg)	1,320 lb (590 kg)	1,070 lb (480 kg)	17 ft 8 in (5.39 m)	1,300 lb (580 kg)	1,060 lb (480 kg)
-2.5 ft (-0.8 m)	4,000 lb* (1 810 kg)*	4,000 lb* (1 810 kg)*	5,190 lb (2 350 kg)	3,950 lb (1 790 kg)	3,110 lb (1 410 kg)	2,470 lb (1 120 kg)	2,180 lb (980 kg)	1,760 lb (790 kg)	1,650 lb (740 kg)	1,350 lb (610 kg)			16 ft 9 in (5.11 m)	1,400 lb (630 kg)	1,150 lb (520 kg)
-5 ft (-1.5 m)	5,810 lb* (2 630 kg)*	5,810 lb* (2 630 kg)*	5,240 lb (2 370 kg)	4,010 lb (1 810 kg)	3,120 lb (1 410 kg)	2,490 lb (1 120 kg)	2,190 lb (990 kg)	1,770 lb (800 kg)	1,660 lb (750 kg)	1,360 lb* (610 kg)*			15 ft 3 in (4.65 m)	1,630 lb (730 kg)	1,330 lb (600 kg)
-7.5 ft (-2.3 m)	8,040 lb* (3 640 kg)*	8,040 lb* (3 640 kg)*	5,350 lb (2 420 kg)	4,100 lb (1 850 kg)	3,190 lb (1 440 kg)	2,540 lb (1 150 kg)	2,240 lb (1 010 kg)	1,820 lb (820 kg)					12 ft 11 in (3.95 m)	2,130 lb (960 kg)	1,730 lb (780 kg)
-10 ft (-3.0 m)	5,820 lb* (2 630 kg)*	5,820 lb* (2 630 kg)*	3,540 lb* (1 600 kg)*	3,540 lb* (1 600 kg)*									8 ft 11 in (2.71 m)	2,780 lb* (1 260 kg)*	2,780 lb* (1 260 kg)*

**Cab Model — 5 ft 6 in (1.69 m) Arm** Lift capacities using 15.7 in (400 mm) shoes, 551 lb (250 kg) counterweight and 247 lb (112 kg) bucket, blade down.

Load (Lift Point Height)	5 ft (1.5 m)		7.5 ft (2.3 m)		10 ft (3.0 m)		12.5 ft (3.8 m)		15 ft (4.6 m)		17.5 ft (5.3 m)		MAXIMUM REACH		
	END	SIDE	END	SIDE	END	SIDE	END	SIDE	END	SIDE	END	SIDE	Radius	END	SIDE
+15 ft (4.6 m)							1,740 lb* (780 kg)*	1,740 lb* (780 kg)*					13 ft 5 in (4.11 m)	1,880 lb* (850 kg)*	1,880 lb* (850 kg)*
+12.5 ft (3.8 m)							1,660 lb* (750 kg)*	1,660 lb* (750 kg)*	1,840 lb* (830 kg)*	1,610 lb (730 kg)			15 ft 7 in (4.76 m)	1,800 lb (810 kg)	1,490 lb (670 kg)
+10 ft (3.0 m)							1,860 lb* (840 kg)*	1,860 lb* (840 kg)*	1,880 lb* (850 kg)*	1,600 lb (720 kg)			16 ft 11 in (5.17 m)	1,530 lb (690 kg)	1,270 lb (570 kg)
+7.5 ft (2.3 m)					2,640 lb* (1 190 kg)*	2,640 lb* (1 190 kg)*	2,280 lb* (1 030 kg)*	2,110 lb (950 kg)	1,880 lb (850 kg)	1,560 lb (700 kg)	1,440 lb (650 kg)	1,180 lb (530 kg)	17 ft 9 in (5.43 m)	1,390 lb (630 kg)	1,140 lb (510 kg)
+5 ft (1.5 m)			4,920 lb* (2 230 kg)*	4,400 lb (1 990 kg)	3,520 lb (1 590 kg)	2,840 lb (1 280 kg)	2,450 lb (1 110 kg)	2,010 lb (910 kg)	1,830 lb (830 kg)	1,500 lb (680 kg)	1,410 lb (630 kg)	1,160 lb (520 kg)	18 ft 2 in (5.54 m)	1,320 lb (590 kg)	1,080 lb (480 kg)
+2.5 ft (0.8 m)			2,900 lb* (1 310 kg)*	2,900 lb* (1 310 kg)*	3,340 lb (1 510 kg)	2,670 lb (1 210 kg)	2,350 lb (1 060 kg)	1,920 lb (870 kg)	1,770 lb (800 kg)	1,450 lb (650 kg)	1,380 lb (620 kg)	1,130 lb (510 kg)	18 ft 1 in (5.53 m)	1,310 lb (590 kg)	1,070 lb (480 kg)
Groundline			4,010 lb* (1 810 kg)*	4,010 lb* (1 810 kg)*	3,240 lb (1 460 kg)	2,580 lb (1 170 kg)	2,290 lb (1 030 kg)	1,850 lb (830 kg)	1,730 lb (780 kg)	1,410 lb (630 kg)	1,360 lb (610 kg)	1,110 lb (500 kg)	17 ft 8 in (5.39 m)	1,340 lb (600 kg)	1,100 lb (490 kg)
-2.5 ft (-0.8 m)	4,000 lb* (1 810 kg)*	4,000 lb* (1 810 kg)*	5,350 lb (2 420 kg)	4,080 lb (1 850 kg)	3,210 lb (1 450 kg)	2,550 lb (1 150 kg)	2,260 lb (1 020 kg)	1,820 lb (820 kg)	1,710 lb (770 kg)	1,390 lb (630 kg)			16 ft 9 in (5.11 m)	1,450 lb (650 kg)	1,190 lb (530 kg)
-5 ft (-1.5 m)	5,810 lb* (2 630 kg)*	5,810 lb* (2 630 kg)*	5,410 lb (2 450 kg)	4,130 lb (1 870 kg)	3,230 lb (1 460 kg)	2,750 lb (1 160 kg)	2,260 lb (1 020 kg)	1,830 lb (830 kg)	1,720 lb (780 kg)	1,400 lb (630 kg)			15 ft 3 in (4.65 m)	1,680 lb (760 kg)	1,370 lb (620 kg)
-7.5 ft (-2.3 m)	8,040 lb* (3 640 kg)*	8,040 lb* (3 640 kg)*	5,520 lb (2 500 kg)	4,220 lb (1 910 kg)	3,290 lb (1 490 kg)	2,620 lb (1 180 kg)	2,310 lb (1 040 kg)	1,880 lb (850 kg)					12 ft 11 in (3.95 m)	2,200 lb (990 kg)	1,790 lb (810 kg)
-10 ft (-3.0 m)	5,820 lb* (2 630 kg)*	5,820 lb* (2 630 kg)*	3,540 lb* (1 600 kg)*	3,540 lb* (1 600 kg)*									8 ft 11 in (2.71 m)	2,780 lb* (1 260 kg)*	2,780 lb* (1 260 kg)*

NOTE: \*Lift capacities do not exceed 75% of the minimum tipping load or 87% of the hydraulic lift capacity. Capacities that are marked with an asterisk are hydraulic limited.

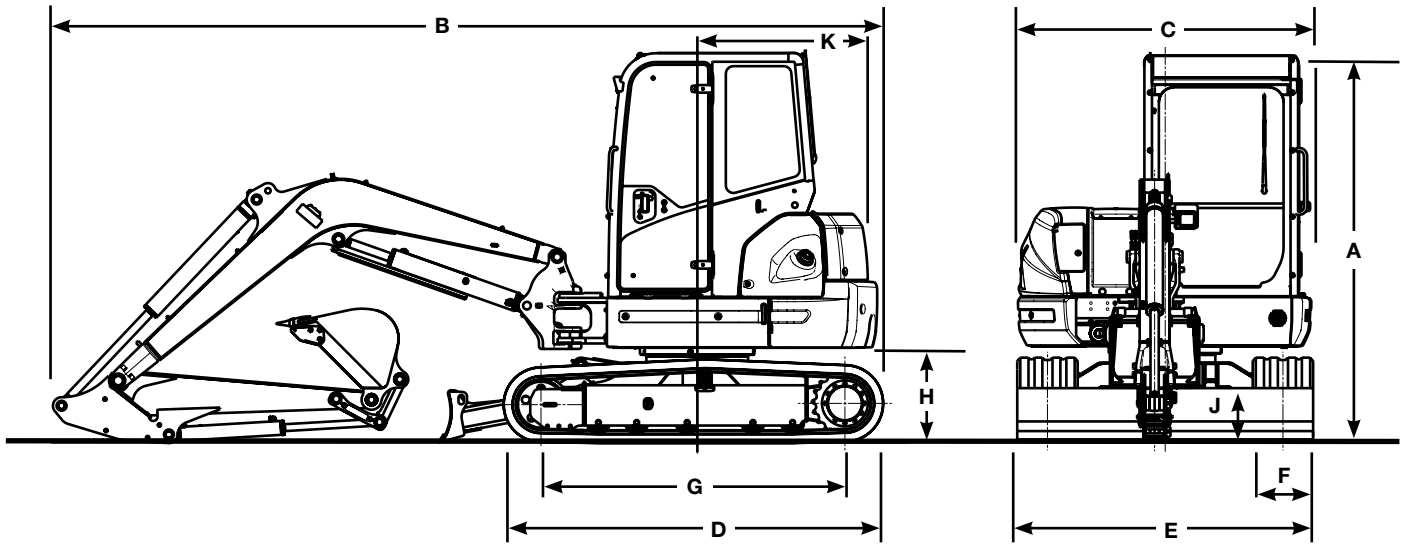

Line drawings are for illustrative purpose only and may not be exact representation of unit.

## DIMENSIONS

	<b>5 ft 6 in (1.69 m) Arm</b>
<b>A.</b> Overall height	8 ft 4 in (2.53 m)
<b>B.</b> Overall length	18 ft 1 in (5.50 m)
<b>C.</b> Width of upper structure	6 ft 4 in (1.94 m)
<b>D.</b> Track overall length	8 ft 2 in (2.50 m)
<b>E.</b> Track overall width with 15.7 in (400 mm) shoes	6 ft 5 in (1.96 m)
<b>F.</b> Track shoe width	15.7 in (400 mm)
<b>G.</b> Center to center – idler to sprocket	6 ft 6 in (1.99 m)
<b>H.</b> Upper structure ground clearance	2 ft 0 in (0.61 m)
<b>J.</b> Backfill blade height	1 ft 2 in (0.35 m)
<b>K.</b> Tail swing radius	3 ft 10 in (1.17 m)
Boom swing	Left 70°/Right 59°
Tail swing overhang	7.5 in (0.19 m)
Operating weight	11,312 lb (5 130 kg)
Ground pressure	4.35 psi (0.30 bar)

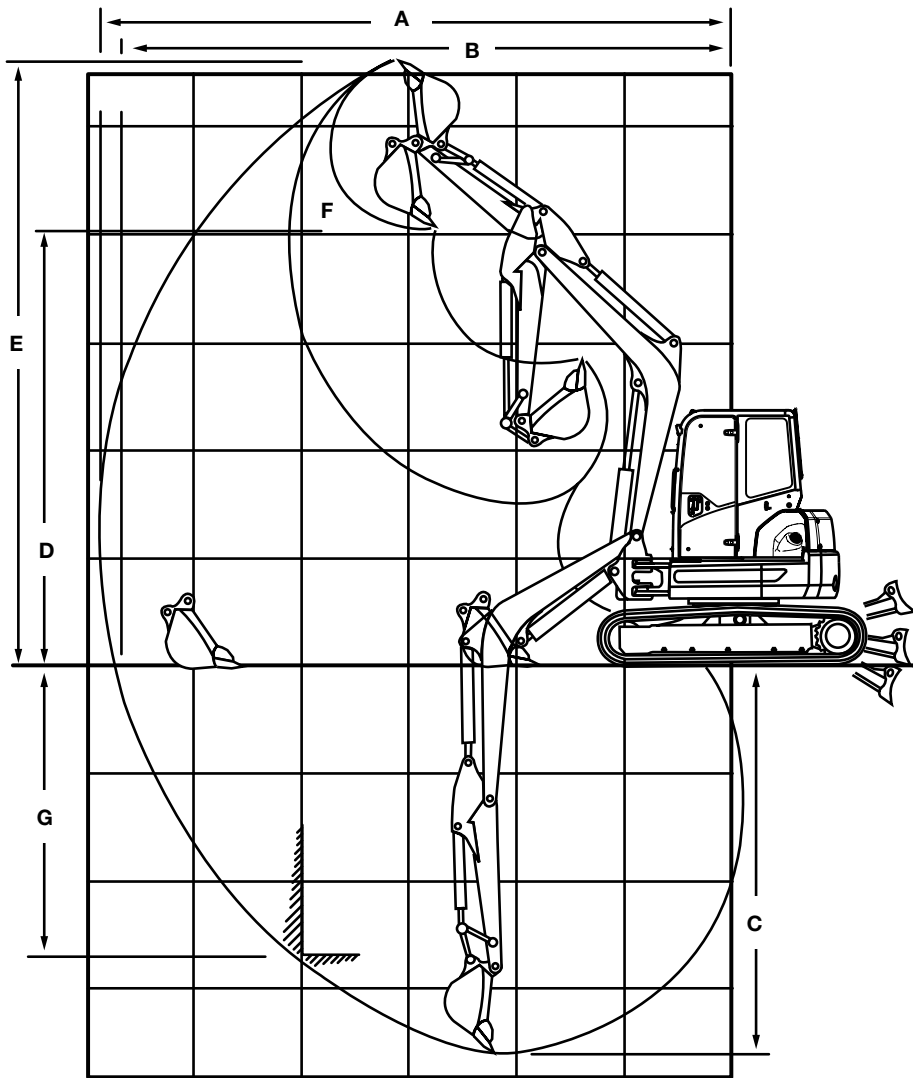

Line drawings are for illustrative purpose only and may not be exact representation of unit.

## DIMENSIONS

	<b>5 ft 6 in (1.69 m) Arm</b>
<b>A.</b> Maximum dig radius	20 ft 6 in (6.24 m)
<b>B.</b> Dig radius at groundline	20 ft 0 in (6.10 m)
<b>C.</b> Maximum dig depth	12 ft 10 in (3.90 m)
<b>D.</b> Dump height	14 ft 3 in (4.35 m)
<b>E.</b> Overall reach height	19 ft 5 in (5.93 m)
<b>F.</b> Bucket rotation	178°
<b>G.</b> Vertical straight wall dig depth	10 ft 4 in (3.14 m)
Arm digging force	5,300 lb (23.6 kN)
Bucket digging force, 1 position bucket	7,000 lb (31.1 kN)
Bucket digging force, 2 position bucket	11,128 lb (49.4 kN)

## STANDARD EQUIPMENT

### OPERATOR ENVIRONMENT

See page 1

### ENGINE

Yanmar 4TNV88-C-PYB diesel  
Tier 4 Final Certified  
4-cycle  
Water cooled  
Direct injection  
One-touch decelerator  
Engine access under rear hood  
Dry-type air cleaner  
Glow plug starting aid  
ECO mode

### ELECTRICAL

12-volt electrical starting system  
Heavy-duty battery  
Horn

### HYDRAULICS

Auxiliary hydraulics (single/bi-directional) and ... plumbing to arm  
Large hydraulic oil cooler  
Control pattern selector valve

### TRACK DRIVE

Rubber tracks  
Automatic 2-speed travel  
Fully hydrostatic drive system  
Sealed and lubricated track rollers  
Track tension adjustment – grease-type  
Disc-type parking brake – auto-release and -apply

### UPPER STRUCTURE

Minimal tail swing  
Swing lock  
Swing brake  
Swing shock valve

### OTHER

Swing boom – 70° left/59° right  
Hydraulic backfill blade  
Eco-friendly diesel fuel drain  
Reinforced boom work light  
Boom cylinder guard  
Thumb bracket

## OPTIONAL EQUIPMENT

### OPERATOR ENVIRONMENT

Cab with heat and AC  
LCD Monitor

### OTHER

Steel tracks  
Mechanical coupler  
2nd auxiliary hydraulics  
4-way hydraulic dozer blade  
Front guard

## BUCKETS

Width	SAE Heaped Capacity	Weight
12 in (305 mm)	3.0 ft <sup>3</sup> (0.085 m <sup>3</sup> )	314 lb (142 kg)
18 in (457 mm)	4.5 ft <sup>3</sup> (0.127 m <sup>3</sup> )	362 lb (164 kg)
24 in (610 mm)	6.3 ft <sup>3</sup> (0.178 m <sup>3</sup> )	435 lb (197 kg)
36 in (914 mm)	9.8 ft <sup>3</sup> (0.277 m <sup>3</sup> )	525 lb (238 kg)



NOTE: All specifications are stated in accordance with SAE Standards or Recommended Practices, where applicable.

NOTE: All engines meet current EPA emissions requirements.

IMPORTANT: Case Construction Equipment Inc. reserves the right to change these specifications without notice and without incurring any obligation relating to such change. Case Construction Equipment Inc. does not warrant the safety or reliability of attachments from other manufacturers.

CASE is a trademark registered in the United States and many other countries, owned by or licensed to CNH Industrial N.V., its subsidiaries or affiliates. CNH Industrial Capital is a trademark in the United States and many other countries, owned by or licensed to CNH Industrial N.V., its subsidiaries or affiliates.



[www.casece.com](http://www.casece.com)

Form No. CCE201404CX55B  
Replaces form no. CCE201103CX55B

Printed in U.S.A.  
CX55B<sub>MTS</sub> • Page 5 of 5

©2014 CNH Industrial America LLC  
All Rights Reserved



All Case construction equipment is biodiesel ready.