



A BRAND AE-VMFE

Advanced Performance Anti-Vibration Reduced Shank Carbide End Mills

Highly Efficient Deep Side Milling

PRIMARY TARGETS

- Customers milling deep walls.
- Depth up to $L/D = 8D$.

SOLUTIONS

- High efficient deep side milling with large step down.
- Available to use with different over hang, up to $8D$.

WHAT OUR CUSTOMERS SEE

- Less chattering + less deflection in deep side milling.

HOW DOES IT WORK?

Variable & Sharp Geometry

- Reduction of Chatter and Good Chip Formation.

Micro-Relief on Cutting Edge

- Add Stability for Long Wall Applications.

Reduced shank type

- No interference, no chip packing between shank and wall.



A
The A Brand

osgtool.com

OSG USA, Inc. : 800-837-2223

OSG Canada, Ltd. : 905-632-8032 • OSG Royco (Mexico) : +52 (722) 279-36-08 to 11

A Brand AE-VMFE

Advanced Performance Anti-Vibration Reduced Shank Carbide End Mills



A Brand AE-VMFE

The A Brand AE-VMFE for deep side milling is an anti-vibration carbide end mill series engineered to excel in a wide range of materials including carbon steel, alloy steel, stainless steel, titanium alloys and Ni-based alloys. With the AE-VMFE deep side milling at L/D of 5D or more can be machined with high efficiency and high accuracy by large step milling up to 2D with its 2.5D cutting length configuration.



Features & Benefits

- **Suppressed Chattering up to L/D of 8** with variable lead, unequal teeth spacing and micro-relief geometry.
- **2.5D Cutting Length** for highly efficient deep side milling is possible.
- **Suppresses Streak Generation** with R-shape on the shank side edge.

List Numbers

8245 - A Brand AE-VMFE (Metric)
8246 - A Brand AE-CR-VMFE (Metric)

Size Range

6mm-12mm
6mm-12mm

Highly Efficient Deep Side Milling

2.5D Cutting Length

Highly efficient deep side milling is possible with large step milling of up to 2xD*.
*The recommended depth of cut varies depending on the overhang length.

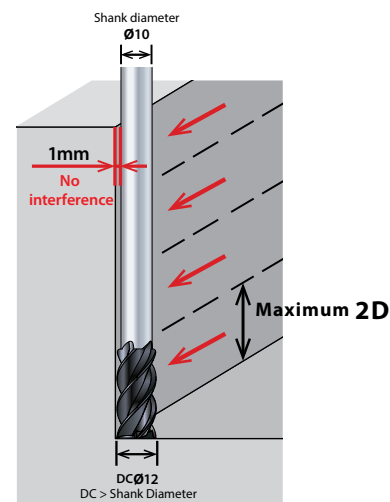

Long Length Reduced Shank Type

Supports Various Machining Depths

Reduced shank types are tools with an outer diameter that is larger than the shank diameter.

- Supports deep side milling and pocket milling of mold parts, etc.
- Supports various machining depth by changing the overhang length.

Reduced Streak Generation

R Shape on the Shank Side Edge

The R Shape on the shank side edge suppresses streak generation by side step milling.



For more information use your phone to scan the QR code to the right and visit: osgtool.com/a-brand-ae-vm



© Copyright 2024 OSG USA, INC. All rights reserved.
EDP#800347CA

osgtool.com
OSG USA, Inc. : 800-837-2223

OSG Canada, Ltd. : 905-632-8032 • OSG Royco (Mexico) : +52 (722) 279-36-08 to 11