

**Models: GLZS4B, GLZS5B, GLZS4M, GLXS3B, GLXS4B, GLXS5B, GLXS4M**

Except as otherwise provided in this document, if this heating or air conditioning unit has not been properly registered, all references in this document to “the warranty,” “this warranty,” or any similar construction, refer solely and exclusively to the Initial Term Warranty (defined below). If this heating or air conditioning unit has been properly registered (and any other applicable conditions set forth in this document are satisfied), all such references refer to the Initial Term Warranty together with the Registered Additional Term Warranty (defined below).

Who Is Providing The Warranty?

This warranty is provided to you by Daikin Comfort Technologies Manufacturing, Inc. (“Daikin”), which warrants all parts of this heating or air conditioning unit, as described below.

To What Type Of Installations Does This Warranty Apply?

This warranty applies to heating and air conditioning units installed in owner-occupied residences. Different warranties apply to units installed in residences not occupied by the owner and in commercial properties.

Is Registration Required?

Registration is strongly urged. As set out below, Initial Term Warranty coverage is available to owners who have not registered, but Registered Additional Term Warranty coverage is only available to registered owners. TO REGISTER, GO TO [WWW.GOODMANMFG.COM](http://WWW.GOODMANMFG.COM) AND CLICK “PRODUCT REGISTRATION.” Some states and provinces do not allow warranty coverage to be conditioned on registration, so the above requirement to register to obtain the Registered Additional Term Warranty may not apply to you. For a list of the states and provinces that do not allow warranty coverage to be conditioned on registration, please visit [www.goodmanmfg.com/warranty-information](http://www.goodmanmfg.com/warranty-information) or, to request a paper copy of this information, please call us at 1-855-502-3903.

What Units Does This Warranty Not Cover?

This warranty does not apply to:

- Units that are ordered over the Internet, by telephone, or by other electronic means unless the unit is installed by a

dealer adhering to all applicable federal, state, and local codes, policies, and licensing requirements.

- Units that are installed outside the United States, its territories, or Canada.
- Units that are operated in incomplete structures.
- Units that are installed in buildings other than owner-occupied residences, such as non-residential buildings or residences not occupied by the owner.

What Problems Does This Warranty Cover?

This warranty covers parts of this heating or air conditioning unit that fail under normal use and maintenance.

Other Warranties

This warranty is in lieu of all other express warranties. **ANY IMPLIED WARRANTIES BY DAIKIN, INCLUDING BUT NOT LIMITED TO WARRANTIES OF MERCHANTABILITY AND FITNESS FOR PARTICULAR PURPOSE, ARE LIMITED TO THE DURATION OF THIS WARRANTY.** Some states and provinces do not allow limitations on how long an implied warranty lasts, so the above limitation may not apply to you.

What Problems Does This Warranty Not Cover?

Daikin is not responsible for:

- Damage or repairs required as a consequence of faulty installation or application.
- Damage as a result of floods, fires, winds, lightning, natural disasters, accidents, corrosive atmosphere, or other conditions beyond Daikin’s control.
- Damage or the need for repairs arising from the use of components or accessories not compatible with this unit.
- Normal maintenance as described in the installation and operating manual, such as cleaning of the coils, filter cleaning and/or replacement, and lubrication.
- Parts or accessories not supplied or designated by the manufacturer.
- Damage or the need for repairs resulting from any improper use, maintenance, operation, or servicing.
- Damage or failure of the unit to start due to interruption, surge, or fluctuation in electrical service or inadequate electrical service.
- Any damage, or the need for any repairs, caused by frozen or broken water pipes, water damage, moisture intrusion, mold or other biological growth.
- Changes in the appearance of the unit that do not affect its performance.

**[www.goodmanmfg.com](http://www.goodmanmfg.com)**

For further information about this warranty, contact Homeowner Support by mail to 19001 Kermier Road, Waller, Texas 77484

Part No. PWGACHPR3BODA  
11/2025

**Thank goodness for Goodman.®**

**Models: GLZS4B, GLZS5B, GLZS4M, GLXS3B, GLXS4B, GLXS5B, GLXS4M**

- Replacement of fuses and replacement or resetting of circuit breakers.
- Damage or the need for repairs resulting from the use of unapproved refrigerant types or used or recycled refrigerant.

When Does Warranty Coverage Begin?

Warranty coverage begins on the "installation date." The installation date is one of three dates depending on the circumstances of purchase:

- (1) For units installed in a newly constructed residence, the installation date is the date the owner purchases the residence from the builder.
- (2) For units installed in existing residences, the installation date is the date that the unit is originally installed.
- (3) Except for California residents, if the date the owner purchases the residence from the builder or the date the unit is originally installed cannot be verified, the installation date is three months after the manufacture date. The first four digits of the serial number (YYMM) on the unit indicate the manufacture date. For example, a serial number beginning with "2511" indicates the unit was manufactured in November 2025.

How Long Does Warranty Coverage Last?

Registration is not required to obtain warranty coverage, but registration entitles the owner to the Registered Additional Term Warranty referred to in the following paragraph. If the unit is not registered, the warranty on all parts lasts for a period of up to 5 YEARS after the installation date (the "Initial Term Warranty").

If the unit is properly registered online within 60 days after the installation date, an additional warranty (the "Registered Additional Term Warranty") is provided. Some states and provinces do not allow warranty coverage to be conditioned on registration, so the above requirement to register online to obtain the Registered Additional Term Warranty may not apply to you. For a list of the states and provinces that do not allow warranty coverage to be conditioned on registration, please visit [www.goodmanmfg.com/warranty-information](http://www.goodmanmfg.com/warranty-information) or, to request a paper copy of this information, please call us at 1-855-502-3903.

The Registered Additional Term Warranty lasts for as long as the original registered owner or his or her spouse ("registered owner") own and reside in the residence in which the unit

was originally installed, for a period of up to 10 YEARS after the installation date, for all parts. The limitation of Registered Additional Term Warranty coverage to the original registered owner does not apply to any owner of a unit installed in any state that requires that the warranty of a heating or air conditioning unit be transferred if the property containing that unit is conveyed to a new owner. For a list of the states that require the warranty of a heating or air conditioning unit to be transferred if the property containing that unit is conveyed to a new owner, please visit [www.goodmanmfg.com/warranty-information](http://www.goodmanmfg.com/warranty-information) or, to request a paper copy of this information, please call us at 1-855-502-3903.

Neither the Initial Term Warranty nor the Registered Additional Term Warranty, if applicable, continues after the unit is removed from the location where it was originally installed.

The replacement of a part under this warranty does not extend the warranty period. In other words, Daikin warrants a replacement part only for the period remaining under the applicable warranty on the original part.

What Will Daikin Do To Correct Problems?

Daikin will furnish a replacement part, without charge for the part only, to replace any part that fails under normal use and maintenance during the warranty period. Furnishing of the replacement part is Daikin's only responsibility under this warranty.

**THE APPLICABLE REMEDIES DESCRIBED IN THIS SECTION ARE DAIKIN'S ONLY RESPONSIBILITIES, AND THE OWNER'S ONLY REMEDIES, FOR ANY BREACH OF THIS WARRANTY OR ANY IMPLIED WARRANTY.**

What Won't Daikin Do To Correct Problems?

Daikin will not pay for:

- Labor, freight, or any other cost associated with the service, repair, or operation of the unit, the deinstallation of any part that fails, or the installation of any replacement part.
- Electricity or fuel costs, or increases in electricity or fuel costs, for any reason, including additional or unusual use of supplemental electric heat.
- Lodging or transportation charges.
- Refrigerant.

**Models: GLZS4B, GLZS5B, GLZS4M, GLXS3B, GLXS4B, GLXS5B, GLXS4M**

**WHETHER ANY CLAIM IS BASED ON NEGLIGENCE OR OTHER TORT, BREACH OF WARRANTY OR OTHER BREACH OF CONTRACT, OR ANY OTHER THEORY, NEITHER DAIKIN NOR ANY OF ITS AFFILIATES SHALL IN ANY EVENT BE LIABLE FOR INCIDENTAL OR CONSEQUENTIAL DAMAGES, INCLUDING BUT NOT LIMITED TO LOST PROFITS, LOSS OF USE OF A UNIT, EXTRA UTILITY EXPENSES, OR DAMAGES TO PROPERTY.**

Some states and provinces do not allow the exclusion or limitation of incidental or consequential damages, so the above exclusion may not apply to you.

How Can The Owner Receive Warranty Service?

If there is a problem with the unit, contact a licensed contractor.

To receive a replacement part, a licensed contractor must bring the failed part to a Daikin heating and air conditioning products distributor.

For more information about the warranty, write to Homeowner Support, 19001 Kermier Road, Waller, Texas 77484.

This warranty gives you specific legal rights, and you may also have other rights that vary from state to state or province to province.

Quebec Residents

The arbitration provisions of this warranty shall not apply to residents of Quebec.

Where Can Any Legal Remedies Be Pursued?

ARBITRATION CLAUSE. IMPORTANT. PLEASE REVIEW THIS ARBITRATION CLAUSE. IT AFFECTS YOUR LEGAL RIGHTS.

1. **Parties:** This arbitration clause affects your rights against Daikin Comfort Technologies North America, Inc. and any of its subsidiaries, including but not limited to Daikin Comfort Technologies Manufacturing, Inc., and its or their employees or agents, successors, or assigns, all of whom together are referred to below as “we” or “us” for ease of reference.
2. **ARBITRATION REQUIREMENT: EXCEPT AS STATED BELOW, ANY DISPUTE BETWEEN YOU AND ANY OF US SHALL BE DECIDED BY NEUTRAL, BINDING ARBITRATION RATHER THAN IN COURT OR BY JURY TRIAL.** “Dispute” will be given the broadest possible meaning allowable by law. It includes any dispute, claim, or controversy arising from or relating to your

purchase of this heating or air conditioning unit, any warranty upon the unit, or the unit’s condition. It also includes determination of the scope or applicability of this Arbitration Clause. The arbitration requirement applies to claims in contract and tort, pursuant to statute, or otherwise.

3. **CLASS-ARBITRATION WAIVER: ARBITRATION IS HANDLED ON AN INDIVIDUAL BASIS. IF A DISPUTE IS ARBITRATED, YOU AND WE EXPRESSLY WAIVE ANY RIGHT TO PARTICIPATE AS A CLASS REPRESENTATIVE OR CLASS MEMBER ON ANY CLASS CLAIM YOU MAY HAVE AGAINST US OR WE AGAINST YOU, OR AS A PRIVATE ATTORNEY GENERAL OR IN ANY OTHER REPRESENTATIVE CAPACITY, TO THE MAXIMUM EXTENT PERMITTED BY LAW. YOU AND WE ALSO WAIVE ANY RIGHT TO PARTICIPATE IN ANY CLASS OR REPRESENTATIVE ACTION IN ANY FORM, INCLUDING ANY CLASS ARBITRATION, OR ANY CONSOLIDATION OF INDIVIDUAL ARBITRATIONS.**
4. **Discovery and Other Rights:** Discovery and rights to appeal in arbitration are generally more limited than in a lawsuit. This applies to both you and us. Other rights that you or we would have in court may not be available in arbitration. Please read this Arbitration Clause and consult the rules of the arbitration organizations listed below for more information.
5. **SMALL CLAIMS COURT OPTION: YOU MAY CHOOSE TO LITIGATE ANY DISPUTE BETWEEN YOU AND ANY OF US IN SMALL CLAIMS COURT, RATHER THAN IN ARBITRATION, IF THE DISPUTE MEETS ALL REQUIREMENTS TO BE HEARD IN SMALL CLAIMS COURT.**
6. **Governing Law:** For residents of the United States, the procedures and effect of the arbitration will be governed by the Federal Arbitration Act (9 U.S.C. § 1 et seq.) rather than by state law concerning arbitration. For residents of Canada, the procedures and effect of the arbitration will be governed by the applicable arbitration law of the province in which you purchased your unit. The law governing your substantive warranty rights and other claims will be the law of the state or province in which your unit was installed. Any court having jurisdiction may enter judgment on the arbitration award.
7. **Rules of the Arbitration:** If the amount in controversy is less than \$250,000, the arbitration will be decided by a single arbitrator. If the amount in controversy

Part No. PWGACHPR3BODA  
11/2025

**Thank goodness for Goodman.®**

**Models: GLZS4B, GLZS5B, GLZS4M, GLXS3B, GLXS4B, GLXS5B, GLXS4M**

is greater than or equal to \$250,000, the arbitration will be decided by a panel of three arbitrators. The arbitrator(s) will be chosen pursuant to the rules of the administering arbitration organization. United States residents may choose JAMS (18881 Von Karman Ave., Suite 350, Irvine, CA 92612, [www.jamsadr.com](http://www.jamsadr.com)) or, subject to our approval, any other arbitration organization. In addition, Canadian residents may choose the ADR Institute of Canada (234 Eglinton Ave. East, Suite 405, Toronto, Ontario, M4P 1K5, [www.amic.org](http://www.amic.org)). These organizations' rules can be obtained by contacting the organization or visiting its website. If the chosen arbitration organization's rules conflict with this Arbitration Clause, the provisions of this Arbitration Clause control. The award of the arbitrator(s) shall be final and binding on all parties.

8. *Location of the Arbitration Hearing:* Unless applicable law provides otherwise, the arbitration hearing for United States residents will be conducted in the federal judicial district in which you reside (in your hometown area) or, for Canadian residents, in the province in which you reside, and if you choose, will be in person.
9. *Costs of the Arbitration:* Each party is responsible for its own attorney, expert, and other costs and fees unless applicable law requires otherwise. Notwithstanding the preceding sentence, and unless applicable law requires otherwise, if you are a consumer under the JAMS rules:
  - (a) if you initiate arbitration, Daikin will pay your share of the costs and fees charged by the arbitration organization and arbitrator(s) beyond the first \$200; and
  - (b) if Daikin initiates arbitration, Daikin will pay all costs and fees charged by the arbitration organization and arbitrator(s).
10. *Survival and Enforceability of this Arbitration Clause:* This Arbitration Clause shall survive the expiration or termination, or any transfer, of the warranty on your unit. If any part of this Arbitration Clause, except waivers of class-action rights, is found to be unenforceable for any reason, the remainder of this clause and the warranty shall remain enforceable. If, in a case in which class-action allegations have been made, the waiver of class-action rights under this warranty is found to be unenforceable with respect to any part of the dispute, the parts of the dispute as to which the waiver of class-action rights have been found unenforceable will be severed and will proceed in court without reference or application of this Arbitration Clause. Any remaining parts will proceed in arbitration.

## Models: GLZS4B, GLZS5B, GLZS4M, GLXS3B, GLXS4B, GLXS5B, GLXS4M

Except as otherwise provided in this document, if this heating or air conditioning unit has not been properly registered, all references in this document to “the warranty,” “this warranty,” or any similar construction, refer solely and exclusively to the Initial Term Warranty (defined below). If this heating or air conditioning unit has been properly registered (and any other applicable conditions set forth in this document are satisfied), all such references refer to the Initial Term Warranty together with the Registered Additional Term Warranty (defined below).

### Who Is Providing The Warranty?

This warranty is provided to you by Daikin Comfort Technologies Manufacturing, Inc. (“Daikin”), which warrants all parts of this heating or air conditioning unit, as described below.

### To What Type Of Installations Does This Warranty Apply?

This warranty applies to heating and air conditioning units installed in residences not occupied by the owner. Different warranties apply to units installed in owner-occupied residences and in commercial properties.

### Is Registration Required?

Registration is strongly urged. As set out below, Initial Term Warranty coverage is available to owners who have not registered, but Registered Additional Term Warranty coverage is only available to registered owners. TO REGISTER, GO TO [WWW.GOODMANMFG.COM](http://WWW.GOODMANMFG.COM) AND CLICK “PRODUCT REGISTRATION.” Some states do not allow warranty coverage on a unit installed at residential real property to be conditioned on registration, so the above requirement to register to obtain the Registered Additional Term Warranty may not apply to you. For a list of the states that do not allow warranty coverage on a unit installed at residential real property to be conditioned on registration, please visit [www.goodmanmfg.com/warranty-information](http://www.goodmanmfg.com/warranty-information) or, to request a paper copy of this information, please call us at 1-855-502-3903.

### What Units Does This Warranty Not Cover?

This warranty does not apply to:

- Units that are ordered over the Internet, by telephone, or by other electronic means unless the unit is installed by a dealer adhering to all applicable federal, state, and local codes, policies, and licensing requirements.
- Units that are installed outside the United States, its territories, or Canada.

- Units that are operated in incomplete structures.
- Units that are installed in buildings other than residences not occupied by the owner, such as non-residential buildings or owner-occupied residences.

### What Problems Does This Warranty Cover?

This warranty covers parts of this heating or air conditioning unit that fail under normal use and maintenance.

### Other Warranties

**THIS WARRANTY IS PROVIDED IN LIEU OF ANY OTHER WARRANTIES, WHETHER BY DAIKIN OR ANY OF ITS AFFILIATES, EXPRESS OR IMPLIED, INCLUDING ANY IMPLIED WARRANTY OF MERCHANTABILITY OR FITNESS FOR A PARTICULAR PURPOSE.**

### What Problems Does This Warranty Not Cover?

Daikin is not responsible for:

- Damage or repairs required as a consequence of faulty installation or application.
- Damage as a result of floods, fires, winds, lightning, natural disasters, accidents, corrosive atmosphere, or other conditions beyond Daikin’s control.
- Damage or the need for repairs arising from the use of components or accessories not compatible with this unit.
- Normal maintenance as described in the installation and operating manual, such as cleaning of the coils, filter cleaning and/or replacement, and lubrication.
- Parts or accessories not supplied or designated by the manufacturer.
- Damage or the need for repairs resulting from any improper use, maintenance, operation, or servicing.
- Damage or failure of the unit to start due to interruption, surge, or fluctuation in electrical service or inadequate electrical service.
- Any damage, or the need for any repairs, caused by frozen or broken water pipes, water damage, moisture intrusion, mold or other biological growth.
- Changes in the appearance of the unit that do not affect its performance.
- Replacement of fuses and replacement or resetting of circuit breakers.
- Damage or the need for repairs resulting from the use of unapproved refrigerant types or used or recycled refrigerant.

**Models: GLZS4B, GLZS5B, GLZS4M, GLXS3B, GLXS4B, GLXS5B, GLXS4M**When Does Warranty Coverage Begin?

Warranty coverage begins on the "installation date." The installation date is one of two dates:

- (1) The installation date is the date that the unit is originally installed.
- (2) If the date the unit is originally installed cannot be verified, the installation date is three months after the manufacture date. The first four digits of the serial number (YYMM) on the unit indicate the manufacture date. For example, a serial number beginning with "2511" indicates the unit was manufactured in November 2025.

How Long Does Warranty Coverage Last?

Registration is not required to obtain warranty coverage, but registration entitles the owner to the Registered Additional Term Warranty referred to in the following paragraph. If the unit is not registered, the warranty on all parts lasts for a period of up to 5 YEARS after the installation date (the "Initial Term Warranty").

If the unit is properly registered online within 60 days after the installation date, an additional warranty (the "Registered Additional Term Warranty") is provided. Some states do not allow warranty coverage on a unit installed at residential real property to be conditioned on registration, so the above requirement to register to obtain the Registered Additional Term Warranty may not apply to you. For a list of the states that do not allow warranty coverage on a unit installed at residential real property to be conditioned on registration, please visit [www.goodmanmfg.com/warranty-information](http://www.goodmanmfg.com/warranty-information) or, to request a paper copy of this information, please call us at 1-855-502-3903.

The Registered Additional Term Warranty lasts for as long as the original registered owner ("registered owner") owns the residence in which the unit was originally installed, for a period of up to 10 YEARS after the installation date, for all parts. The limitation of Registered Additional Term Warranty coverage to the original registered owner does not apply to any owner of a unit installed at residential real property in any state that requires that the warranty of such unit be transferred if the property containing that unit is conveyed to a new owner. For a list of the states that require the warranty of a unit installed at residential real property to be transferred

if the property containing that unit is conveyed to a new owner, please visit [www.goodmanmfg.com/warranty-information](http://www.goodmanmfg.com/warranty-information) or, to request a paper copy of this information, please call us at 1-855-502-3903.

Neither the Initial Term Warranty nor the Registered Additional Term Warranty, if applicable, continues after the unit is removed from the location where it was originally installed.

The replacement of a part under this warranty does not extend the warranty period. In other words, Daikin warrants a replacement part only for the period remaining under the applicable warranty on the original part.

What Will Daikin Do To Correct Problems?

Daikin will furnish a replacement part, without charge for the part only, to replace any part that fails under normal use and maintenance during the warranty period. Furnishing of the replacement part is Daikin's only responsibility under this warranty.

**THE APPLICABLE REMEDIES DESCRIBED IN THIS SECTION ARE DAIKIN'S ONLY RESPONSIBILITIES, AND THE OWNER'S ONLY REMEDIES, FOR ANY BREACH OF THIS WARRANTY OR ANY IMPLIED WARRANTY.**

What Won't Daikin Do To Correct Problems?

Daikin will not pay for:

- Labor, freight, or any other cost associated with the service, repair, or operation of the unit, the deinstallation of any part that fails, or the installation of any replacement part.
- Electricity or fuel costs, or increases in electricity or fuel costs, for any reason, including additional or unusual use of supplemental electric heat.
- Lodging or transportation charges.
- Refrigerant.

**WHETHER ANY CLAIM IS BASED ON NEGLIGENCE OR OTHER TORT, BREACH OF WARRANTY OR OTHER BREACH OF CONTRACT, OR ANY OTHER THEORY, NEITHER DAIKIN NOR ANY OF ITS AFFILIATES SHALL IN ANY EVENT BE LIABLE FOR INCIDENTAL OR CONSEQUENTIAL DAMAGES, INCLUDING BUT NOT LIMITED TO LOST PROFITS, LOSS OF USE OF A UNIT, EXTRA UTILITY EXPENSES, OR DAMAGES TO PROPERTY.**

## Models: GLZS4B, GLZS5B, GLZS4M, GLXS3B, GLXS4B, GLXS5B, GLXS4M

### How Can The Owner Receive Warranty Service?

If there is a problem with the unit, contact a licensed contractor.

To receive a replacement part, a licensed contractor must bring the failed part to a Daikin heating and air conditioning products distributor.

For more information about the warranty, write to Homeowner Support, 19001 Kermier Road, Waller, Texas 77484.

### Where Can Any Legal Remedies Be Pursued?

ARBITRATION CLAUSE. IMPORTANT. PLEASE REVIEW THIS ARBITRATION CLAUSE. IT AFFECTS YOUR LEGAL RIGHTS.

1. **Parties:** This arbitration clause affects your rights against Daikin Comfort Technologies North America, Inc. and any of its subsidiaries, including but not limited to Daikin Comfort Technologies Manufacturing, Inc., and its or their employees or agents, successors, or assigns, all of whom together are referred to below as “we” or “us” for ease of reference.
2. **ARBITRATION REQUIREMENT: EXCEPT AS STATED BELOW, ANY DISPUTE BETWEEN YOU AND ANY OF US SHALL BE DECIDED BY NEUTRAL, BINDING ARBITRATION RATHER THAN IN COURT OR BY JURY TRIAL.** “Dispute” will be given the broadest possible meaning allowable by law. It includes any dispute, claim, or controversy arising from or relating to your purchase of this heating or air conditioning unit, any warranty upon the unit, or the unit’s condition. It also includes determination of the scope or applicability of this Arbitration Clause. The arbitration requirement applies to claims in contract and tort, pursuant to statute, or otherwise.
3. **CLASS-ARBITRATION WAIVER: ARBITRATION IS HANDLED ON AN INDIVIDUAL BASIS. IF A DISPUTE IS ARBITRATED, YOU AND WE EXPRESSLY WAIVE ANY RIGHT TO PARTICIPATE AS A CLASS REPRESENTATIVE OR CLASS MEMBER ON ANY CLASS CLAIM YOU MAY HAVE AGAINST US OR WE AGAINST YOU, OR AS A PRIVATE ATTORNEY GENERAL OR IN ANY OTHER REPRESENTATIVE CAPACITY, TO THE MAXIMUM EXTENT PERMITTED BY LAW. YOU AND WE ALSO WAIVE ANY RIGHT TO PARTICIPATE IN ANY CLASS OR REPRESENTATIVE ACTION IN ANY FORM, INCLUDING ANY CLASS ARBITRATION, OR ANY CONSOLIDATION OF INDIVIDUAL ARBITRATIONS.**
4. **Discovery and Other Rights:** Discovery and rights to appeal in arbitration are generally more limited than in a lawsuit. This applies to both you and us. Other rights that you or we would have in court may not be available in arbitration. Please read this Arbitration Clause and consult the rules of the arbitration organizations listed below for more information.
5. **SMALL CLAIMS COURT OPTION: YOU MAY CHOOSE TO LITIGATE ANY DISPUTE BETWEEN YOU AND ANY OF US IN SMALL CLAIMS COURT, RATHER THAN IN ARBITRATION, IF THE DISPUTE MEETS ALL REQUIREMENTS TO BE HEARD IN SMALL CLAIMS COURT.**
6. **Governing Law:** For residents of the United States, the procedures and effect of the arbitration will be governed by the Federal Arbitration Act (9 U.S.C. § 1 et seq.) rather than by state law concerning arbitration. For residents of Canada, the procedures and effect of the arbitration will be governed by the applicable arbitration law of the province in which you purchased your unit. The law governing your substantive warranty rights and other claims will be the law of the state or province in which your unit was installed. Any court having jurisdiction may enter judgment on the arbitration award.
7. **Rules of the Arbitration:** If the amount in controversy is less than \$250,000, the arbitration will be decided by a single arbitrator. If the amount in controversy is greater than or equal to \$250,000, the arbitration will be decided by a panel of three arbitrators. The arbitrator(s) will be chosen pursuant to the rules of the administering arbitration organization. United States residents may choose JAMS (18881 Von Karman Ave., Suite 350, Irvine, CA 92612, [www.jamsadr.com](http://www.jamsadr.com)) or, subject to our approval, any other arbitration organization. In addition, Canadian residents may choose the ADR Institute of Canada (234 Eglinton Ave. East, Suite 405, Toronto, Ontario, M4P 1K5, [www.amic.org](http://www.amic.org)). These organizations’ rules can be obtained by contacting the organization or visiting its website. If the chosen arbitration organization’s rules conflict with this Arbitration Clause, the provisions of this Arbitration Clause control. The award of the arbitrator(s) shall be final and binding on all parties.

Part No. PWGACHPR3BODA  
11/2025

**Thank goodness for Goodman®**

**Models: GLZS4B, GLZS5B, GLZS4M, GLXS3B, GLXS4B, GLXS5B, GLXS4M**

8. *Location of the Arbitration Hearing:* Unless applicable law provides otherwise, the arbitration hearing for United States residents will be conducted in the federal judicial district in which you reside (in your hometown area) or, for Canadian residents, in the province in which you reside, and if you choose, will be in person.
9. *Costs of the Arbitration:* Each party is responsible for its own attorney, expert, and other costs and fees unless applicable law requires otherwise. Notwithstanding the preceding sentence, and unless applicable law requires otherwise, if you are a consumer under the JAMS rules:
  - (a) if you initiate arbitration, Daikin will pay your share of the costs and fees charged by the arbitration organization and arbitrator(s) beyond the first \$200; and
  - (b) if Daikin initiates arbitration, Daikin will pay all costs and fees charged by the arbitration organization and arbitrator(s).
10. *Survival and Enforceability of this Arbitration Clause:* This Arbitration Clause shall survive the expiration or termination, or any transfer, of the warranty on your unit. If any part of this Arbitration Clause, except waivers of class-action rights, is found to be unenforceable for any reason, the remainder of this clause and the warranty shall remain enforceable. If, in a case in which class-action allegations have been made, the waiver of class-action rights under this warranty is found to be unenforceable with respect to any part of the dispute, the parts of the dispute as to which the waiver of class-action rights have been found unenforceable will be severed and will proceed in court without reference or application of this Arbitration Clause. Any remaining parts will proceed in arbitration.

## Models: GLZS4B, GLZS5B, GLZS4M, GLXS3B, GLXS4B, GLXS5B, GLXS4M

### Who Is Providing The Warranty?

This warranty is provided to you by Daikin Comfort Technologies Manufacturing, Inc. ("Daikin"), which warrants all parts of this heating or air conditioning unit, as described below.

### To What Type Of Installations Does This Warranty Apply?

This warranty applies to heating and air conditioning units installed in buildings other than residences. Different warranties apply to units installed in owner-occupied residences and in residences not occupied by the owner.

### What Units Does This Warranty Not Cover?

This warranty does not apply to:

- Units that are ordered over the Internet, by telephone, or by other electronic means unless the unit is installed by a dealer adhering to all applicable federal, state, and local codes, policies, and licensing requirements.
- Units that are installed outside the United States, its territories, or Canada.
- Units that are operated in incomplete structures.
- Units that are installed in residential buildings.

### What Problems Does This Warranty Cover?

This warranty covers parts of this heating or air conditioning unit that fail under normal use and maintenance.

### Other Warranties

**THIS WARRANTY IS PROVIDED IN LIEU OF ANY OTHER WARRANTIES, WHETHER BY DAIKIN OR ANY OF ITS AFFILIATES, EXPRESS OR IMPLIED, INCLUDING ANY IMPLIED WARRANTY OF MERCHANTABILITY OR FITNESS FOR A PARTICULAR PURPOSE.**

### What Problems Does This Warranty Not Cover?

Daikin is not responsible for:

- Damage or repairs required as a consequence of faulty installation or application.
- Damage as a result of floods, fires, winds, lightning, natural disasters, accidents, corrosive atmosphere, or other conditions beyond Daikin's control.
- Damage or the need for repairs arising from the use of components or accessories not compatible with this unit.
- Normal maintenance as described in the installation and operating manual, such as cleaning of the coils, filter cleaning and/or replacement, and lubrication.

- Parts or accessories not supplied or designated by the manufacturer.
- Damage or the need for repairs resulting from any improper use, maintenance, operation, or servicing.
- Damage or failure of the unit to start due to interruption, surge, or fluctuation in electrical service or inadequate electrical service.
- Any damage, or the need for any repairs, caused by frozen or broken water pipes, water damage, moisture intrusion, mold or other biological growth.
- Changes in the appearance of the unit that do not affect its performance.
- Replacement of fuses and replacement or resetting of circuit breakers.
- Damage or the need for repairs resulting from the use of unapproved refrigerant types or used or recycled refrigerant.

### When Does Warranty Coverage Begin?

Warranty coverage begins on the "installation date." The installation date is one of two dates:

- (1) The installation date is the date that the unit is originally installed.
- (2) If the date the unit is originally installed cannot be verified, the installation date is three months after the manufacture date. The first four digits of the serial number (YYMM) on the unit indicate the manufacture date. For example, a serial number beginning with "2511" indicates the unit was manufactured in November 2025.

### How Long Does Warranty Coverage Last?

The warranty on all parts lasts for a period of up to 5 YEARS after the installation date.

This warranty period does not continue after the unit is removed from the location where it was originally installed.

The replacement of a part under this warranty does not extend the warranty period. In other words, Daikin warrants a replacement part only for the period remaining under the applicable warranty on the original part.

**Models: GLZS4B, GLZS5B, GLZS4M, GLXS3B, GLXS4B, GLXS5B, GLXS4M**

What Will Daikin Do To Correct Problems?

Daikin will furnish a replacement part, without charge for the part only, to replace any part that fails under normal use and maintenance during the warranty period. Furnishing of the replacement part is Daikin's only responsibility under this warranty.

**THE REMEDIES DESCRIBED IN THIS SECTION ARE DAIKIN'S ONLY RESPONSIBILITIES, AND THE OWNER'S ONLY REMEDIES, FOR ANY BREACH OF ANY WARRANTY.**

What Won't Daikin Do To Correct Problems?

Daikin will not pay for:

- Labor, freight, or any other cost associated with the service, repair, or operation of the unit, the deinstallation of any part that fails, or the installation of any replacement part.
- Electricity or fuel costs, or increases in electricity or fuel costs, for any reason, including additional or unusual use of supplemental electric heat.
- Lodging or transportation charges.
- Refrigerant.

**WHETHER ANY CLAIM IS BASED ON NEGLIGENCE OR OTHER TORT, BREACH OF WARRANTY OR OTHER BREACH OF CONTRACT, OR ANY OTHER THEORY, NEITHER DAIKIN NOR ANY OF ITS AFFILIATES SHALL IN ANY EVENT BE LIABLE FOR INCIDENTAL OR CONSEQUENTIAL DAMAGES, INCLUDING BUT NOT LIMITED TO LOST PROFITS, LOSS OF USE OF A UNIT, EXTRA UTILITY EXPENSES, OR DAMAGES TO PROPERTY.**

How Can The Owner Receive Warranty Service?

If there is a problem with the unit, contact a licensed contractor.

To receive a replacement part, a licensed contractor must bring the failed part to a Daikin heating and air conditioning products distributor.

For more information about the warranty, write to Homeowner Support, 19001 Kermier Road, Waller, Texas 77484.

Where Can Any Legal Remedies Be Pursued?

**ARBITRATION CLAUSE. IMPORTANT. PLEASE REVIEW THIS ARBITRATION CLAUSE. IT AFFECTS YOUR LEGAL RIGHTS.**

1. *Parties:* This arbitration clause affects your rights against Daikin Comfort Technologies North America, Inc. and any of its subsidiaries, including but not limited to Daikin Comfort Technologies Manufacturing, Inc., and its or their employees or agents, successors, or assigns, all of whom together are referred to below as "we" or "us" for ease of reference.
2. **ARBITRATION REQUIREMENT: EXCEPT AS STATED BELOW, ANY DISPUTE BETWEEN YOU AND ANY OF US SHALL BE DECIDED BY NEUTRAL, BINDING ARBITRATION RATHER THAN IN COURT OR BY JURY TRIAL.** "Dispute" will be given the broadest possible meaning allowable by law. It includes any dispute, claim, or controversy arising from or relating to your purchase of this heating or air conditioning unit, any warranty upon the unit, or the unit's condition. It also includes determination of the scope or applicability of this Arbitration Clause. The arbitration requirement applies to claims in contract and tort, pursuant to statute, or otherwise.
3. **CLASS-ARBITRATION WAIVER: ARBITRATION IS HANDLED ON AN INDIVIDUAL BASIS. IF A DISPUTE IS ARBITRATED, YOU AND WE EXPRESSLY WAIVE ANY RIGHT TO PARTICIPATE AS A CLASS REPRESENTATIVE OR CLASS MEMBER ON ANY CLASS CLAIM YOU MAY HAVE AGAINST US OR WE AGAINST YOU, OR AS A PRIVATE ATTORNEY GENERAL OR IN ANY OTHER REPRESENTATIVE CAPACITY, TO THE MAXIMUM EXTENT PERMITTED BY LAW. YOU AND WE ALSO WAIVE ANY RIGHT TO PARTICIPATE IN ANY CLASS OR REPRESENTATIVE ACTION IN ANY FORM, INCLUDING ANY CLASS ARBITRATION, OR ANY CONSOLIDATION OF INDIVIDUAL ARBITRATIONS.**
4. *Discovery and Other Rights:* Discovery and rights to appeal in arbitration are generally more limited than in a lawsuit. This applies to both you and us. Other rights that you or we would have in court may not be available in arbitration. Please read this Arbitration Clause and consult the rules of the arbitration organizations listed below for more information.

**Models: GLZS4B, GLZS5B, GLZS4M, GLXS3B, GLXS4B, GLXS5B, GLXS4M**

5. **SMALL CLAIMS COURT OPTION: YOU MAY CHOOSE TO LITIGATE ANY DISPUTE BETWEEN YOU AND ANY OF US IN SMALL CLAIMS COURT, RATHER THAN IN ARBITRATION, IF THE DISPUTE MEETS ALL REQUIREMENTS TO BE HEARD IN SMALL CLAIMS COURT.**
6. *Governing Law:* For residents of the United States, the procedures and effect of the arbitration will be governed by the Federal Arbitration Act (9 U.S.C. § 1 et seq.) rather than by state law concerning arbitration. For residents of Canada, the procedures and effect of the arbitration will be governed by the applicable arbitration law of the province in which you purchased your unit. The law governing your substantive warranty rights and other claims will be the law of the state or province in which your unit was installed. Any court having jurisdiction may enter judgment on the arbitration award.
7. *Rules of the Arbitration:* If the amount in controversy is less than \$250,000, the arbitration will be decided by a single arbitrator. If the amount in controversy is greater than or equal to \$250,000, the arbitration will be decided by a panel of three arbitrators. The arbitrator(s) will be chosen pursuant to the rules of the administering arbitration organization. United States residents may choose JAMS (18881 Von Karman Ave., Suite 350, Irvine, CA 92612, [www.jamsadr.com](http://www.jamsadr.com)) or, subject to our approval, any other arbitration organization. In addition, Canadian residents may choose the ADR Institute of Canada (234 Eglinton Ave. East, Suite 405, Toronto, Ontario, M4P 1K5, [www.amic.org](http://www.amic.org)). These organizations' rules can be obtained by contacting the organization or visiting its website. If the chosen arbitration organization's rules conflict with this Arbitration Clause, the provisions of this Arbitration Clause control. The award of the arbitrator(s) shall be final and binding on all parties.
8. *Location of the Arbitration Hearing:* Unless applicable law provides otherwise, the arbitration hearing for United States residents will be conducted in the federal judicial district in which you reside (in your hometown area) or, for Canadian residents, in the province in which you reside, and if you choose, will be in person.
9. *Costs of the Arbitration:* Each party is responsible for its own attorney, expert, and other costs and fees unless applicable law requires otherwise. Each party is also responsible for one-half of any costs and fees charged by the arbitration organization and arbitrator(s) to administer the arbitration to the maximum extent permitted by law or rule. Where permissible by law, the prevailing party may be required to reimburse the other party for the costs and fees of the arbitration organization and arbitrator(s) in whole or in part by decision of the arbitrator(s) at the discretion of the arbitrator(s).
10. *Survival and Enforceability of this Arbitration Clause:* This Arbitration Clause shall survive the expiration or termination, or any transfer, of the warranty on your unit. If any part of this Arbitration Clause, except waivers of class-action rights, is found to be unenforceable for any reason, the remainder of this clause and the warranty shall remain enforceable. If, in a case in which class-action allegations have been made, the waiver of class-action rights under this warranty is found to be unenforceable with respect to any part of the dispute, the parts of the dispute as to which the waiver of class-action rights have been found unenforceable will be severed and will proceed in court without reference or application of this Arbitration Clause. Any remaining parts will proceed in arbitration.

**Models: CCVS80, CCVS96, GCVC80, GMVC80, GCVC96, GCVM97, GMVC96, GMVM97, GMVS80, GMVS96, GC9C96, GD9S96, GD9T80, GD9T96, GDVM97, GDVT80, GDVT96, GM9C96, GC9C80, GM9C80, GC9S96, GM9S96, GCEC96, GCEC80, GMEC80, GCE96, GMEC96, GMES96, GR9S96, GR9T80, GR9T96, GRVM97, GRVT80, GRVT96, GRVS80, GRVS96, CDVS96**

Except as otherwise provided in this document, if this heating or air conditioning unit has not been properly registered, all references in this document to “the warranty,” “this warranty,” or any similar construction, refer solely and exclusively to the Initial Term Warranty (defined below). If this heating or air conditioning unit has been properly registered (and any other applicable conditions set forth in this document are satisfied), all such references refer to the Initial Term Warranty together with the Registered Additional Term Warranty (defined below).

Who Is Providing The Warranty?

This warranty is provided to you by Daikin Comfort Technologies Manufacturing, L.P. (“Daikin”), which warrants all parts of this heating or air conditioning unit, as described below.

To What Type Of Installations Does This Warranty Apply?

This warranty applies to heating and air conditioning units installed in owner-occupied residences. Different warranties apply to units installed in residences not occupied by the owner and in commercial properties.

Is Registration Required?

Registration is strongly urged. As set out below, Initial Term Warranty coverage is available to owners who have not registered, but Registered Additional Term Warranty coverage is only available to registered owners and provides some additional remedies. TO REGISTER, GO TO [WWW.GOODMANMFG.COM](http://WWW.GOODMANMFG.COM) AND CLICK “PRODUCT REGISTRATION.” Some states and provinces do not allow warranty coverage to be conditioned on registration, so the above requirement to register to obtain the Registered Additional Term Warranty may not apply to you. For a list of the states and provinces that do not allow warranty coverage to be conditioned on registration, please visit [www.goodmanmfg.com/warranty-information](http://www.goodmanmfg.com/warranty-information) or, to request a paper copy of this information, please write to us at 19001 Kermier Rd., Waller, TX 77484, Attn: Homeowner Support, or call us at 1-855-502-3903.

**[www.goodmanmfg.com](http://www.goodmanmfg.com)**

For further information about this warranty, contact Homeowner Support by mail to 19001 Kermier Road, Waller, Texas 77484

What Units Does This Warranty Not Cover?

This warranty does not apply to:

- Units that are ordered over the Internet, by telephone, or by other electronic means unless the unit is installed by a dealer adhering to all applicable federal, state, and local codes, policies, and licensing requirements.
- Units that are installed outside the United States, its territories, or Canada.
- Units that are operated in incomplete structures.
- Units that are installed in buildings other than owner-occupied residences, such as non-residential buildings or residences not occupied by the owner.

What Problems Does This Warranty Cover?

This warranty covers parts of this heating or air conditioning unit that fail under normal use and maintenance.

Other Warranties

This warranty is in lieu of all other express warranties. **ANY IMPLIED WARRANTIES BY DAIKIN, INCLUDING BUT NOT LIMITED TO WARRANTIES OF MERCHANTABILITY AND FITNESS FOR PARTICULAR PURPOSE, ARE LIMITED TO THE DURATION OF THIS WARRANTY.** Some states and provinces do not allow limitations on how long an implied warranty lasts, so the above limitation may not apply to you.

What Problems Does This Warranty Not Cover?

Daikin is not responsible for:

- Damage or repairs required as a consequence of faulty installation or application.
- Damage as a result of floods, fires, winds, lightning, natural disasters, accidents, corrosive atmosphere, or other conditions beyond Daikin’s control.
- Damage or the need for repairs arising from the use of components or accessories not compatible with this unit.
- Normal maintenance as described in the installation and operating manual, such as cleaning of the coils, filter cleaning and/or replacement, and lubrication.
- Parts or accessories not supplied or designated by the manufacturer.
- Damage or the need for repairs resulting from any improper use, maintenance, operation, or servicing.

**Models: CCVS80, CCVS96, GCVC80, GMVC80, GCVC96, GCVM97, GMVC96, GMVM97, GMVS80, GMVS96, GC9C96, GD9S96, GD9T80, GD9T96, GDVM97, GDVT80, GDVT96, GM9C96, GC9C80, GM9C80, GC9S96, GM9S96, GCEC96, GCEC80, GMEC80, GCES96, GMEC96, GMES96, GR9S96, GR9T80, GR9T96, GRVM97, GRVT80, GRVT96, GRVS80, GRVS96, CDVS96**

- Damage or failure of the unit to start due to interruption, surge, or fluctuation in electrical service or inadequate electrical service.
- Any damage, or the need for any repairs, caused by frozen or broken water pipes, water damage, moisture intrusion, mold or other biological growth.
- Changes in the appearance of the unit that do not affect its performance.
- Replacement of fuses and replacement or resetting of circuit breakers.

#### When Does Warranty Coverage Begin?

Warranty coverage begins on the "installation date." The installation date is one of three dates depending on the circumstances of purchase:

- (1) For units installed in a newly constructed residence, the installation date is the date the owner purchases the residence from the builder.
- (2) For units installed in existing residences, the installation date is the date that the unit is originally installed.
- (3) Except for California residents, if the date the owner purchases the residence from the builder or the date the unit is originally installed cannot be verified, the installation date is three months after the manufacture date. The first four digits of the serial number (YYMM) on the unit indicate the manufacture date. For example, a serial number beginning with "2504" indicates the unit was manufactured in April 2025.

#### How Long Does Warranty Coverage Last?

Registration is not required to obtain warranty coverage, but registration entitles the owner to the Registered Additional Term Warranty referred to in the following paragraph. If the unit is not registered, the warranty lasts for a period of up to (1) 20 YEARS after the installation date for the heat exchanger and (2) 5 YEARS after the installation date for all other parts (the "Initial Term Warranty").

If the unit is properly registered online within 60 days after the installation date, an additional warranty (the "Registered Additional Term Warranty") is provided. Some states and provinces do not allow warranty coverage to be conditioned on registration, so the above requirement to register online to obtain the Registered Additional Term Warranty may not apply to you. For a list of the states

and provinces that do not allow warranty coverage to be conditioned on registration, please visit [www.goodmanmfg.com/warranty-information](http://www.goodmanmfg.com/warranty-information) or, to request a paper copy of this information, please write to us at 19001 Kermier Rd., Waller, TX 77484, Attn: Homeowner Support, or call us at 1-855-502-3903.

The Registered Additional Term Warranty lasts for as long as the original registered owner or his or her spouse ("registered owner") owns and resides in the residence in which the unit was originally installed, for a period of up to (1) for the heat exchanger, until the remedies applicable to units that are affected by failed heat exchangers (described in the following section) have been provided or the term of availability of those remedies has expired, and (2) 10 YEARS after the installation date for all other parts. The limitation of Registered Additional Term Warranty coverage to the original registered owner does not apply to any owner of a unit installed in any state that requires that the warranty of a heating or air conditioning unit be transferred if the property containing that unit is conveyed to a new owner. For a list of the states that require the warranty of a heating or air conditioning unit to be transferred if the property containing that unit is conveyed to a new owner, please visit [www.goodmanmfg.com/warranty-information](http://www.goodmanmfg.com/warranty-information) or, to request a paper copy of this information, please write to us at 19001 Kermier Rd., Waller, TX 77484, Attn: Homeowner Support, or call us at 1-855-502-3903.

Neither the Initial Term Warranty nor the Registered Additional Term Warranty, if applicable, continues after the unit is removed from the location where it was originally installed.

The replacement of a part or unit under this warranty does not extend the warranty period. In other words, Daikin warrants a replacement part or unit only for the period remaining under the applicable warranty on the original part or unit.

#### What Will Daikin Do To Correct Problems?

##### *Failed Heat Exchanger in a Registered Unit*

If the heat exchanger in any properly registered unit fails during the first 10 YEARS after the installation date, Daikin

**Models: CCVS80, CCVS96, GCVC80, GMVC80, GCVC96, GCVM97, GMVC96, GMVM97, GMVS80, GMVS96, GC9C96, GD9S96, GD9T80, GD9T96, GDVM97, GDVT80, GDVT96, GM9C96, GC9C80, GM9C80, GC9S96, GM9S96, GCEC96, GCEC80, GMEC80, GCE96, GMEC96, GMES96, GR9S96, GR9T80, GR9T96, GRVM97, GRVT80, GRVT96, GRVS80, GRVS96, CDVS96**

will, except as set forth below, furnish a new, equivalent unit to replace the entire unit, once only, without charge. Some states and provinces do not allow warranty coverage to be conditioned on registration, so the above requirement to properly register the unit to obtain unit replacement may not apply to you. For a list of the states and provinces that do not allow warranty coverage to be conditioned on registration, please visit [www.goodmanmfg.com/warranty-information](http://www.goodmanmfg.com/warranty-information) or, to request a paper copy of this information, please write to us at 19001 Kermier Rd., Waller, TX 77484, Attn: Homeowner Support, or call us at 1-855-502-3903.

If a new, equivalent unit is not available due to changes in any law, regulation, technology, refrigerant or other reason, Daikin will provide the latest new unit available, only once, during the first 10 YEARS after the installation date. However, installation of the latest new unit available may require changes to or replacement of other components and/or accessories to your heating, ventilation and air conditioning ("HVAC") system that you will be responsible for changing or replacing at your expense. If permitted by then applicable law and regulations, in lieu of receiving the latest new unit available, you may choose to receive a replacement heat exchanger, without charge, to replace any failed heat exchanger in a covered unit during the warranty period.

If the heat exchanger in any unit that is properly registered fails within the first 20 YEARS after the installation date, Daikin will furnish a replacement heat exchanger without charge. In addition, if the heat exchanger in any unit that is properly registered fails after the first 20 YEARS after the installation date, but within the first 99 YEARS after the installation date, Daikin will furnish a replacement heat exchanger without charge, once only. Some states and provinces do not allow warranty coverage to be conditioned on registration, so the above requirement to properly register the unit to obtain a replacement heat exchanger may not apply to you. For a list of the states and provinces that do not allow warranty coverage to be conditioned on registration, please visit [www.goodmanmfg.com/warranty-information](http://www.goodmanmfg.com/warranty-information) or, to request a paper copy of this information, please write to us at 19001 Kermier Rd., Waller, TX 77484, Attn: Homeowner Support, or call us at 1-855-502-3903.

#### *Remedies Generally*

Unless one of the remedies above applies, Daikin will furnish a replacement part, without charge for the part only, to replace any part that fails under normal use and maintenance during the warranty period.

#### *Other Remedies*

**THE APPLICABLE REMEDIES DESCRIBED IN THIS SECTION ARE DAIKIN'S ONLY RESPONSIBILITIES, AND THE OWNER'S ONLY REMEDIES, FOR ANY BREACH OF THIS WARRANTY OR ANY IMPLIED WARRANTY.**

#### What Won't Daikin Do To Correct Problems?

Daikin will not pay for:

- Labor, freight, or any other cost associated with the service, repair, or operation of the unit, the deinstallation of any unit or part that fails, or the installation of any replacement unit or part.
- Electricity or fuel costs, or increases in electricity or fuel costs, for any reason, including additional or unusual use of supplemental electric heat.
- Lodging or transportation charges.

**WHETHER ANY CLAIM IS BASED ON NEGLIGENCE OR OTHER TORT, BREACH OF WARRANTY OR OTHER BREACH OF CONTRACT, OR ANY OTHER THEORY, NEITHER DAIKIN NOR ANY OF ITS AFFILIATES SHALL IN ANY EVENT BE LIABLE FOR INCIDENTAL OR CONSEQUENTIAL DAMAGES, INCLUDING BUT NOT LIMITED TO LOST PROFITS, LOSS OF USE OF A UNIT, EXTRA UTILITY EXPENSES, OR DAMAGES TO PROPERTY.**

Some states and provinces do not allow the exclusion or limitation of incidental or consequential damages, so the above exclusion may not apply to you.

#### How Can The Owner Receive Warranty Service?

If there is a problem with the unit, contact a licensed contractor.

To receive a replacement unit when applicable, a licensed contractor must bring the unit to a Daikin heating and air conditioning products distributor.

**Models: CCVS80, CCVS96, GCVC80, GMVC80, GCVC96, GCVM97, GMVC96, GMVM97, GMVS80, GMVS96, GC9C96, GD9S96, GD9T80, GD9T96, GDVM97, GDVT80, GDVT96, GM9C96, GC9C80, GM9C80, GC9S96, GM9S96, GCEC96, GCEC80, GMEC80, GCES96, GMEC96, GMES96, GR9S96, GR9T80, GR9T96, GRVM97, GRVT80, GRVT96, GRVS80, GRVS96, CDVS96**

To receive a replacement part, a licensed contractor must bring the failed part to a Daikin heating and air conditioning products distributor.

For more information about the warranty, write to Homeowner Support, 19001 Kermier Road, Waller, Texas 77484.

This warranty gives you specific legal rights, and you may also have other rights that vary from state to state or province to province.

Quebec Residents

The arbitration provisions of this warranty shall not apply to residents of Quebec.

Where Can Any Legal Remedies Be Pursued?

ARBITRATION CLAUSE. IMPORTANT. PLEASE REVIEW THIS ARBITRATION CLAUSE. IT AFFECTS YOUR LEGAL RIGHTS.

1. *Parties:* This arbitration clause affects your rights against Daikin Comfort Technologies North America, Inc. and any of its subsidiaries, including but not limited to Daikin Comfort Technologies Manufacturing, L.P., and its or their employees or agents, successors, or assigns, all of whom together are referred to below as “we” or “us” for ease of reference.
2. **ARBITRATION REQUIREMENT: EXCEPT AS STATED BELOW, ANY DISPUTE BETWEEN YOU AND ANY OF US SHALL BE DECIDED BY NEUTRAL, BINDING ARBITRATION RATHER THAN IN COURT OR BY JURY TRIAL.** “Dispute” will be given the broadest possible meaning allowable by law. It includes any dispute, claim, or controversy arising from or relating to your purchase of this heating or air conditioning unit, any warranty upon the unit, or the unit’s condition. It also includes determination of the scope or applicability of this Arbitration Clause. The arbitration requirement applies to claims in contract and tort, pursuant to statute, or otherwise.
3. **CLASS-ARBITRATION WAIVER: ARBITRATION IS HANDLED ON AN INDIVIDUAL BASIS. IF A DISPUTE IS ARBITRATED, YOU AND WE EXPRESSLY WAIVE ANY RIGHT TO PARTICIPATE AS A CLASS REPRESENTATIVE OR CLASS MEMBER ON ANY CLASS CLAIM YOU MAY**

**HAVE AGAINST US OR WE AGAINST YOU, OR AS A PRIVATE ATTORNEY GENERAL OR IN ANY OTHER REPRESENTATIVE CAPACITY, TO THE MAXIMUM EXTENT PERMITTED BY LAW. YOU AND WE ALSO WAIVE ANY RIGHT TO PARTICIPATE IN ANY CLASS OR REPRESENTATIVE ACTION IN ANY FORM, INCLUDING ANY CLASS ARBITRATION, OR ANY CONSOLIDATION OF INDIVIDUAL ARBITRATIONS.**

4. *Discovery and Other Rights:* Discovery and rights to appeal in arbitration are generally more limited than in a lawsuit. This applies to both you and us. Other rights that you or we would have in court may not be available in arbitration. Please read this Arbitration Clause and consult the rules of the arbitration organizations listed below for more information.
5. **SMALL CLAIMS COURT OPTION: YOU MAY CHOOSE TO LITIGATE ANY DISPUTE BETWEEN YOU AND ANY OF US IN SMALL CLAIMS COURT, RATHER THAN IN ARBITRATION, IF THE DISPUTE MEETS ALL REQUIREMENTS TO BE HEARD IN SMALL CLAIMS COURT.**
6. *Governing Law:* For residents of the United States, the procedures and effect of the arbitration will be governed by the Federal Arbitration Act (9 U.S.C. § 1 et seq.) rather than by state law concerning arbitration. For residents of Canada, the procedures and effect of the arbitration will be governed by the applicable arbitration law of the province in which you purchased your unit. The law governing your substantive warranty rights and other claims will be the law of the state or province in which your unit was installed. Any court having jurisdiction may enter judgment on the arbitration award.
7. *Rules of the Arbitration:* If the amount in controversy is less than \$250,000, the arbitration will be decided by a single arbitrator. If the amount in controversy is greater than or equal to \$250,000, the arbitration will be decided by a panel of three arbitrators. The arbitrator(s) will be chosen pursuant to the rules of the administering arbitration organization. United States residents may choose JAMS (1920 Main Street, Ste. 300, Irvine, CA 92614, www.jamsadr.com) or, subject to our approval, any other arbitration organization. In addition, Canadian residents may choose the ADR Institute

**Models: CCVS80, CCVS96, GCVC80, GMVC80, GCVC96, GCVM97, GMVC96, GMVM97, GMVS80, GMVS96, GC9C96, GD9S96, GD9T80, GD9T96, GDVM97, GDVT80, GDVT96, GM9C96, GC9C80, GM9C80, GC9S96, GM9S96, GCEC96, GCEC80, GMEC80, GCE96, GMEC96, GMES96, GR9S96, GR9T80, GR9T96, GRVM97, GRVT80, GRVT96, GRVS80, GRVS96, CDVS96**

of Canada (234 Eglinton Ave. East, Suite 405, Toronto, Ontario, M4P 1K5, [www.amic.org](http://www.amic.org)). These organizations' rules can be obtained by contacting the organization or visiting its website. If the chosen arbitration organization's rules conflict with this Arbitration Clause, the provisions of this Arbitration Clause control. The award of the arbitrator(s) shall be final and binding on all parties.

8. *Location of the Arbitration Hearing:* Unless applicable law provides otherwise, the arbitration hearing for United States residents will be conducted in the federal judicial district in which you reside (in your hometown area) or, for Canadian residents, in the province in which you reside, and if you choose, will be in person.
9. *Costs of the Arbitration:* Each party is responsible for its own attorney, expert, and other costs and fees unless applicable law requires otherwise. Notwithstanding the preceding sentence, and unless applicable law requires otherwise, if you are a consumer under the JAMS rules:  
(a) if you initiate arbitration, Daikin will pay your share of the costs and fees charged by the arbitration organization and arbitrator(s) beyond the first \$200; and (b) if Daikin initiates arbitration, Daikin will pay all costs and fees charged by the arbitration organization and arbitrator(s).
10. *Survival and Enforceability of this Arbitration Clause:* This Arbitration Clause shall survive the expiration or termination, or any transfer, of the warranty on your unit. If any part of this Arbitration Clause, except waivers of class-action rights, is found to be unenforceable for any reason, the remainder of this clause and the warranty shall remain enforceable. If, in a case in which class-action allegations have been made, the waiver of class-action rights under this warranty is found to be unenforceable with respect to any part of the dispute, the parts of the dispute as to which the waiver of class-action rights have been found unenforceable will be severed and will proceed in court without reference or application of this Arbitration Clause. Any remaining parts will proceed in arbitration.

**Models: CCVS80, CCVS96, GCVC80, GMVC80, GCVC96, GCVM97, GMVC96, GMVM97, GMVS80, GMVS96, GC9C96, GD9S96, GD9T80, GD9T96, GDVM97, GDVT80, GDVT96, GM9C96, GC9C80, GM9C80, GC9S96, GM9S96, GCEC96, GCEC80, GMEC80, GCES96, GMEC96, GMES96, GR9S96, GR9T80, GR9T96, GRVM97, GRVT80, GRVT96, GRVS80, GRVS96, CDVS96**

Except as otherwise provided in this document, if this heating or air conditioning unit has not been properly registered, all references in this document to “the warranty,” “this warranty,” or any similar construction, refer solely and exclusively to the Initial Term Warranty (defined below). If this heating or air conditioning unit has been properly registered (and any other applicable conditions set forth in this document are satisfied), all such references refer to the Initial Term Warranty together with the Registered Additional Term Warranty (defined below).

#### Who Is Providing The Warranty?

This warranty is provided to you by Daikin Comfort Technologies Manufacturing, L.P. (“Daikin”), which warrants all parts of this heating or air conditioning unit, as described below.

#### To What Type Of Installations Does This Warranty Apply?

This warranty applies to heating and air conditioning units installed in residences not occupied by the owner. Different warranties apply to units installed in owner-occupied residences and in commercial properties.

#### Is Registration Required?

Registration is strongly urged. As set out below, Initial Term Warranty coverage is available to owners who have not registered, but Registered Additional Term Warranty coverage is only available to registered owners. TO REGISTER, GO TO [WWW.GOODMANMFG.COM](http://WWW.GOODMANMFG.COM) AND CLICK “PRODUCT REGISTRATION.” Some states do not allow warranty coverage on a unit installed at residential real property to be conditioned on registration, so the above requirement to register to obtain the Registered Additional Term Warranty may not apply to you. For a list of the states that do not allow warranty coverage on a unit installed at residential real property to be conditioned on registration, please visit [www.goodmanmfg.com/warranty-information](http://www.goodmanmfg.com/warranty-information) or, to request a paper copy of this information, please write to us at 19001 Kermier Rd., Waller, TX 77484, Attn: Homeowner Support, or call us at 1-855-502-3903.

#### What Units Does This Warranty Not Cover?

This warranty does not apply to:

- Units that are ordered over the Internet, by telephone, or by other electronic means unless the unit is installed by a

dealer adhering to all applicable federal, state, and local codes, policies, and licensing requirements.

- Units that are installed outside the United States, its territories, or Canada.
- Units that are operated in incomplete structures.
- Units that are installed in buildings other than residences not occupied by the owner, such as non-residential buildings or owner-occupied residences.

#### What Problems Does This Warranty Cover?

This warranty covers parts of this heating or air conditioning unit that fail under normal use and maintenance.

#### Other Warranties

**THIS WARRANTY IS PROVIDED IN LIEU OF ANY OTHER WARRANTIES, WHETHER BY DAIKIN OR ANY OF ITS AFFILIATES, EXPRESS OR IMPLIED, INCLUDING ANY IMPLIED WARRANTY OF MERCHANTABILITY OR FITNESS FOR A PARTICULAR PURPOSE.**

#### What Problems Does This Warranty Not Cover?

Daikin is not responsible for:

- Damage or repairs required as a consequence of faulty installation or application.
- Damage as a result of floods, fires, winds, lightning, natural disasters, accidents, corrosive atmosphere, or other conditions beyond Daikin’s control.
- Damage or the need for repairs arising from the use of components or accessories not compatible with this unit.
- Normal maintenance as described in the installation and operating manual, such as cleaning of the coils, filter cleaning and/or replacement, and lubrication.
- Parts or accessories not supplied or designated by the manufacturer.
- Damage or the need for repairs resulting from any improper use, maintenance, operation, or servicing.
- Damage or failure of the unit to start due to interruption, surge, or fluctuation in electrical service or inadequate electrical service.
- Any damage, or the need for any repairs, caused by frozen or broken water pipes, water damage, moisture intrusion, mold or other biological growth.
- Changes in the appearance of the unit that do not affect its performance.

**Models: CCVS80, CCVS96, GCVC80, GMVC80, GCVC96, GCVM97, GMVC96, GMVM97, GMVS80, GMVS96, GC9C96, GD9S96, GD9T80, GD9T96, GDVM97, GDVT80, GDVT96, GM9C96, GC9C80, GM9C80, GC9S96, GM9S96, GCEC96, GCEC80, GMEC80, GCE96, GMEC96, GMES96, GR9S96, GR9T80, GR9T96, GRVM97, GRVT80, GRVT96, GRVS80, GRVS96, CDVS96**

- Replacement of fuses and replacement or resetting of circuit breakers.

#### When Does Warranty Coverage Begin?

Warranty coverage begins on the “installation date.” The installation date is one of two dates:

- (1) The installation date is the date that the unit is originally installed.
- (2) If the date the unit is originally installed cannot be verified, the installation date is three months after the manufacture date. The first four digits of the serial number (YYMM) on the unit indicate the manufacture date. For example, a serial number beginning with “2504” indicates the unit was manufactured in April 2025.

#### How Long Does Warranty Coverage Last?

Registration is not required to obtain warranty coverage, but registration entitles the owner to the Registered Additional Term Warranty referred to in the following paragraph. If the unit is not registered, the warranty lasts for a period of up to (1) 20 YEARS after the installation date for the heat exchanger and (2) 5 YEARS after the installation date for all other parts (the “Initial Term Warranty”).

If the unit is properly registered online within 60 days after the installation date, an additional warranty (the “Registered Additional Term Warranty”) is provided. Some states do not allow warranty coverage on a unit installed at residential real property to be conditioned on registration, so the above requirement to register to obtain the Registered Additional Term Warranty may not apply to you. For a list of the states that do not allow warranty coverage on a unit installed at residential real property to be conditioned on registration, please visit [www.goodmanmfg.com/warranty-information](http://www.goodmanmfg.com/warranty-information) or, to request a paper copy of this information, please write to us at 19001 Kermier Rd., Waller, TX 77484, Attn: Homeowner Support, or call us at 1-855-502-3903.

The Registered Additional Term Warranty lasts for as long as the original registered owner (“registered owner”) owns the residence in which the unit was originally installed, for a period of up to (1) 20 YEARS after the installation date for the heat exchanger, and (2) 10 YEARS after the installation date

for all other parts. The limitation of Registered Additional Term Warranty coverage to the original registered owner does not apply to any owner of a unit installed at residential real property in any state that requires that the warranty of such unit be transferred if the property containing that unit is conveyed to a new owner. For a list of the states that require the warranty of a unit installed at residential real property to be transferred if the property containing that unit is conveyed to a new owner, please visit [www.goodmanmfg.com/warranty-information](http://www.goodmanmfg.com/warranty-information) or, to request a paper copy of this information, please write to us at 19001 Kermier Rd., Waller, TX 77484, Attn: Homeowner Support, or call us at 1-855-502-3903.

Neither the Initial Term Warranty nor the Registered Additional Term Warranty, if applicable, continues after the unit is removed from the location where it was originally installed.

The replacement of a part under this warranty does not extend the warranty period. In other words, Daikin warrants a replacement part only for the period remaining under the applicable warranty on the original part.

#### What Will Daikin Do To Correct Problems?

Daikin will furnish a replacement part, without charge for the part only, to replace any part that fails under normal use and maintenance during the warranty period. Furnishing of the replacement part is Daikin’s only responsibility under this warranty.

**THE APPLICABLE REMEDIES DESCRIBED IN THIS SECTION ARE DAIKIN’S ONLY RESPONSIBILITIES, AND THE OWNER’S ONLY REMEDIES, FOR ANY BREACH OF THIS WARRANTY OR ANY IMPLIED WARRANTY.**

#### What Won’t Daikin Do To Correct Problems?

Daikin will not pay for:

- Labor, freight, or any other cost associated with the service, repair, or operation of the unit, the deinstallation of any part that fails, or the installation of any replacement part.

**Models: CCVS80, CCVS96, GCVC80, GMVC80, GCVC96, GCVM97, GMVC96, GMVM97, GMVS80, GMVS96, GC9C96, GD9S96, GD9T80, GD9T96, GDVM97, GDVT80, GDVT96, GM9C96, GC9C80, GM9C80, GC9S96, GM9S96, GCEC96, GCEC80, GMEC80, GCES96, GMEC96, GMES96, GR9S96, GR9T80, GR9T96, GRVM97, GRVT80, GRVT96, GRVS80, GRVS96, CDVS96**

- Electricity or fuel costs, or increases in electricity or fuel costs, for any reason, including additional or unusual use of supplemental electric heat.
- Lodging or transportation charges.

**WHETHER ANY CLAIM IS BASED ON NEGLIGENCE OR OTHER TORT, BREACH OF WARRANTY OR OTHER BREACH OF CONTRACT, OR ANY OTHER THEORY, NEITHER DAIKIN NOR ANY OF ITS AFFILIATES SHALL IN ANY EVENT BE LIABLE FOR INCIDENTAL OR CONSEQUENTIAL DAMAGES, INCLUDING BUT NOT LIMITED TO LOST PROFITS, LOSS OF USE OF A UNIT, EXTRA UTILITY EXPENSES, OR DAMAGES TO PROPERTY.**

How Can The Owner Receive Warranty Service?

If there is a problem with the unit, contact a licensed contractor.

To receive a replacement part, a licensed contractor must bring the failed part to a Daikin heating and air conditioning products distributor.

For more information about the warranty, write to Homeowner Support, 19001 Kermier Road, Waller, Texas 77484.

Where Can Any Legal Remedies Be Pursued?

ARBITRATION CLAUSE. IMPORTANT. PLEASE REVIEW THIS ARBITRATION CLAUSE. IT AFFECTS YOUR LEGAL RIGHTS.

1. *Parties:* This arbitration clause affects your rights against Daikin Comfort Technologies North America, Inc. and any of its subsidiaries, including but not limited to Daikin Comfort Technologies Manufacturing, L.P., and its or their employees or agents, successors, or assigns, all of whom together are referred to below as “we” or “us” for ease of reference.
2. **ARBITRATION REQUIREMENT: EXCEPT AS STATED BELOW, ANY DISPUTE BETWEEN YOU AND ANY OF US SHALL BE DECIDED BY NEUTRAL, BINDING ARBITRATION RATHER THAN IN COURT OR BY JURY TRIAL.** “Dispute” will be given the broadest possible meaning allowable by law. It includes any dispute, claim, or controversy arising from or relating to your purchase of this heating or air conditioning unit, any

warranty upon the unit, or the unit’s condition. It also includes determination of the scope or applicability of this Arbitration Clause. The arbitration requirement applies to claims in contract and tort, pursuant to statute, or otherwise.

3. **CLASS-ARBITRATION WAIVER: ARBITRATION IS HANDLED ON AN INDIVIDUAL BASIS. IF A DISPUTE IS ARBITRATED, YOU AND WE EXPRESSLY WAIVE ANY RIGHT TO PARTICIPATE AS A CLASS REPRESENTATIVE OR CLASS MEMBER ON ANY CLASS CLAIM YOU MAY HAVE AGAINST US OR WE AGAINST YOU, OR AS A PRIVATE ATTORNEY GENERAL OR IN ANY OTHER REPRESENTATIVE CAPACITY, TO THE MAXIMUM EXTENT PERMITTED BY LAW. YOU AND WE ALSO WAIVE ANY RIGHT TO PARTICIPATE IN ANY CLASS OR REPRESENTATIVE ACTION IN ANY FORM, INCLUDING ANY CLASS ARBITRATION, OR ANY CONSOLIDATION OF INDIVIDUAL ARBITRATIONS.**
4. *Discovery and Other Rights:* Discovery and rights to appeal in arbitration are generally more limited than in a lawsuit. This applies to both you and us. Other rights that you or we would have in court may not be available in arbitration. Please read this Arbitration Clause and consult the rules of the arbitration organizations listed below for more information.
5. **SMALL CLAIMS COURT OPTION: YOU MAY CHOOSE TO LITIGATE ANY DISPUTE BETWEEN YOU AND ANY OF US IN SMALL CLAIMS COURT, RATHER THAN IN ARBITRATION, IF THE DISPUTE MEETS ALL REQUIREMENTS TO BE HEARD IN SMALL CLAIMS COURT.**
6. *Governing Law:* For residents of the United States, the procedures and effect of the arbitration will be governed by the Federal Arbitration Act (9 U.S.C. § 1 et seq.) rather than by state law concerning arbitration. For residents of Canada, the procedures and effect of the arbitration will be governed by the applicable arbitration law of the province in which you purchased your unit. The law governing your substantive warranty rights and other claims will be the law of the state or province in which your unit was installed. Any court having jurisdiction may enter judgment on the arbitration award.

**Models: CCVS80, CCVS96, GCVC80, GMVC80, GCVC96, GCVM97, GMVC96, GMVM97, GMVS80, GMVS96, GC9C96, GD9S96, GD9T80, GD9T96, GDVM97, GDVT80, GDVT96, GM9C96, GC9C80, GM9C80, GC9S96, GM9S96, GCEC96, GCEC80, GMEC80, GCE96, GMEC96, GMES96, GR9S96, GR9T80, GR9T96, GRVM97, GRVT80, GRVT96, GRVS80, GRVS96, CDVS96**

7. *Rules of the Arbitration:* If the amount in controversy is less than \$250,000, the arbitration will be decided by a single arbitrator. If the amount in controversy is greater than or equal to \$250,000, the arbitration will be decided by a panel of three arbitrators. The arbitrator(s) will be chosen pursuant to the rules of the administering arbitration organization. United States residents may choose JAMS (1920 Main Street, Ste. 300, Irvine, CA 92614, [www.jamsadr.com](http://www.jamsadr.com)) or, subject to our approval, any other arbitration organization. In addition, Canadian residents may choose the ADR Institute of Canada (234 Eglinton Ave. East, Suite 405, Toronto, Ontario, M4P 1K5, [www.amic.org](http://www.amic.org)). These organizations' rules can be obtained by contacting the organization or visiting its website. If the chosen arbitration organization's rules conflict with this Arbitration Clause, the provisions of this Arbitration Clause control. The award of the arbitrator(s) shall be final and binding on all parties.
8. *Location of the Arbitration Hearing:* Unless applicable law provides otherwise, the arbitration hearing for United States residents will be conducted in the federal judicial district in which you reside (in your hometown area) or, for Canadian residents, in the province in which you reside, and if you choose, will be in person.
9. *Costs of the Arbitration:* Each party is responsible for its own attorney, expert, and other costs and fees unless applicable law requires otherwise. Notwithstanding the preceding sentence, and unless applicable law requires otherwise, if you are a consumer under the JAMS rules: (a) if you initiate arbitration, Daikin will pay your share of the costs and fees charged by the arbitration organization and arbitrator(s) beyond the first \$200; and (b) if Daikin initiates arbitration, Daikin will pay all costs and fees charged by the arbitration organization and arbitrator(s).
10. *Survival and Enforceability of this Arbitration Clause:* This Arbitration Clause shall survive the expiration or termination, or any transfer, of the warranty on your unit. If any part of this Arbitration Clause, except waivers of class-action rights, is found to be unenforceable for any reason, the remainder of this clause and the warranty shall remain enforceable. If, in a case in which class-action allegations have been made, the waiver of class-action rights under this warranty is found to be unenforceable with respect to any part of the dispute, the parts of the dispute as to which the waiver of class-action rights have been found unenforceable will be severed and will proceed in court without reference or application of this Arbitration Clause. Any remaining parts will proceed in arbitration.

**Models: CCVS80, CCVS96, GCVC80, GMVC80, GCVC96, GCVM97, GMVC96, GMVM97, GMVS80, GMVS96, GC9C96, GD9S96, GD9T80, GD9T96, GDVM97, GDVT80, GDVT96, GM9C96, GC9C80, GM9C80, GC9S96, GM9S96, GCEC96, GCEC80, GMEC80, GCES96, GMEC96, GMES96, GR9S96, GR9T80, GR9T96, GRVM97, GRVT80, GRVT96, GRVS80, GRVS96, CDVS96**

#### Who Is Providing The Warranty?

This warranty is provided to you by Daikin Comfort Technologies Manufacturing, L.P. ("Daikin"), which warrants all parts of this heating or air conditioning unit, as described below.

#### To What Type Of Installations Does This Warranty Apply?

This warranty applies to heating and air conditioning units installed in buildings other than residences. Different warranties apply to units installed in owner-occupied residences and in residences not occupied by the owner.

#### What Units Does This Warranty Not Cover?

This warranty does not apply to:

- Units that are ordered over the Internet, by telephone, or by other electronic means unless the unit is installed by a dealer adhering to all applicable federal, state, and local codes, policies, and licensing requirements.
- Units that are installed outside the United States, its territories, or Canada.
- Units that are operated in incomplete structures.
- Units that are installed in residential buildings.

#### What Problems Does This Warranty Cover?

This warranty covers parts of this heating or air conditioning unit that fail under normal use and maintenance.

#### Other Warranties

**THIS WARRANTY IS PROVIDED IN LIEU OF ANY OTHER WARRANTIES, WHETHER BY DAIKIN OR ANY OF ITS AFFILIATES, EXPRESS OR IMPLIED, INCLUDING ANY IMPLIED WARRANTY OF MERCHANTABILITY OR FITNESS FOR A PARTICULAR PURPOSE.**

#### What Problems Does This Warranty Not Cover?

Daikin is not responsible for:

- Damage or repairs required as a consequence of faulty installation or application.
- Damage as a result of floods, fires, winds, lightning, natural disasters, accidents, corrosive atmosphere, or other conditions beyond Daikin's control.
- Damage or the need for repairs arising from the use of components or accessories not compatible with this unit.

- Normal maintenance as described in the installation and operating manual, such as cleaning of the coils, filter cleaning and/or replacement, and lubrication.
- Parts or accessories not supplied or designated by the manufacturer.
- Damage or the need for repairs resulting from any improper use, maintenance, operation, or servicing.
- Damage or failure of the unit to start due to interruption, surge, or fluctuation in electrical service or inadequate electrical service.
- Any damage, or the need for any repairs, caused by frozen or broken water pipes, water damage, moisture intrusion, mold or other biological growth.
- Changes in the appearance of the unit that do not affect its performance.
- Replacement of fuses and replacement or resetting of circuit breakers.

#### When Does Warranty Coverage Begin?

Warranty coverage begins on the "installation date." The installation date is one of two dates:

- (1) The installation date is the date that the unit is originally installed.
- (2) If the date the unit is originally installed cannot be verified, the installation date is three months after the manufacture date. The first four digits of the serial number (YYMM) on the unit indicate the manufacture date. For example, a serial number beginning with "2504" indicates the unit was manufactured in April 2025.

#### How Long Does Warranty Coverage Last?

The warranty lasts for a period of up to (1) 20 YEARS after the installation date for the heat exchanger and (2) 5 YEARS after the installation date for all other parts.

This warranty period does not continue after the unit is removed from the location where it was originally installed.

The replacement of a part under this warranty does not extend the warranty period. In other words, Daikin warrants a replacement part only for the period remaining under the applicable warranty on the original part.

**Models: CCVS80, CCVS96, GCVC80, GMVC80, GCVC96, GCVM97, GMVC96, GMVM97, GMVS80, GMVS96, GC9C96, GD9S96, GD9T80, GD9T96, GDVM97, GDVT80, GDVT96, GM9C96, GC9C80, GM9C80, GC9S96, GM9S96, GCEC96, GCEC80, GMEC80, GCE96, GMEC96, GMES96, GR9S96, GR9T80, GR9T96, GRVM97, GRVT80, GRVT96, GRVS80, GRVS96, CDVS96**

What Will Daikin Do To Correct Problems?

Daikin will furnish a replacement part, without charge for the part only, to replace any part that fails under normal use and maintenance during the warranty period. Furnishing of the replacement part is Daikin's only responsibility under this warranty.

**THE REMEDIES DESCRIBED IN THIS SECTION ARE DAIKIN'S ONLY RESPONSIBILITIES, AND THE OWNER'S ONLY REMEDIES, FOR ANY BREACH OF ANY WARRANTY.**

What Won't Daikin Do To Correct Problems?

Daikin will not pay for:

- Labor, freight, or any other cost associated with the service, repair, or operation of the unit, the deinstallation of any part that fails, or the installation of any replacement part.
- Electricity or fuel costs, or increases in electricity or fuel costs, for any reason, including additional or unusual use of supplemental electric heat.
- Lodging or transportation charges.

**WHETHER ANY CLAIM IS BASED ON NEGLIGENCE OR OTHER TORT, BREACH OF WARRANTY OR OTHER BREACH OF CONTRACT, OR ANY OTHER THEORY, NEITHER DAIKIN NOR ANY OF ITS AFFILIATES SHALL IN ANY EVENT BE LIABLE FOR INCIDENTAL OR CONSEQUENTIAL DAMAGES, INCLUDING BUT NOT LIMITED TO LOST PROFITS, LOSS OF USE OF A UNIT, EXTRA UTILITY EXPENSES, OR DAMAGES TO PROPERTY.**

How Can The Owner Receive Warranty Service?

If there is a problem with the unit, contact a licensed contractor.

To receive a replacement part, a licensed contractor must bring the failed part to a Daikin heating and air conditioning products distributor.

For more information about the warranty, write to Homeowner Support, 19001 Kermier Road, Waller, Texas 77484.

Where Can Any Legal Remedies Be Pursued?

ARBITRATION CLAUSE. IMPORTANT. PLEASE REVIEW THIS ARBITRATION CLAUSE. IT AFFECTS YOUR LEGAL RIGHTS.

1. *Parties:* This arbitration clause affects your rights against Daikin Comfort Technologies North America, Inc. and any of its subsidiaries, including but not limited to Daikin Comfort Technologies Manufacturing, L.P., and its or their employees or agents, successors, or assigns, all of whom together are referred to below as "we" or "us" for ease of reference.
2. **ARBITRATION REQUIREMENT: EXCEPT AS STATED BELOW, ANY DISPUTE BETWEEN YOU AND ANY OF US SHALL BE DECIDED BY NEUTRAL, BINDING ARBITRATION RATHER THAN IN COURT OR BY JURY TRIAL.** "Dispute" will be given the broadest possible meaning allowable by law. It includes any dispute, claim, or controversy arising from or relating to your purchase of this heating or air conditioning unit, any warranty upon the unit, or the unit's condition. It also includes determination of the scope or applicability of this Arbitration Clause. The arbitration requirement applies to claims in contract and tort, pursuant to statute, or otherwise.
3. **CLASS-ARBITRATION WAIVER: ARBITRATION IS HANDLED ON AN INDIVIDUAL BASIS. IF A DISPUTE IS ARBITRATED, YOU AND WE EXPRESSLY WAIVE ANY RIGHT TO PARTICIPATE AS A CLASS REPRESENTATIVE OR CLASS MEMBER ON ANY CLASS CLAIM YOU MAY HAVE AGAINST US OR WE AGAINST YOU, OR AS A PRIVATE ATTORNEY GENERAL OR IN ANY OTHER REPRESENTATIVE CAPACITY, TO THE MAXIMUM EXTENT PERMITTED BY LAW. YOU AND WE ALSO WAIVE ANY RIGHT TO PARTICIPATE IN ANY CLASS OR REPRESENTATIVE ACTION IN ANY FORM, INCLUDING ANY CLASS ARBITRATION, OR ANY CONSOLIDATION OF INDIVIDUAL ARBITRATIONS.**
4. *Discovery and Other Rights:* Discovery and rights to appeal in arbitration are generally more limited than in a lawsuit. This applies to both you and us. Other rights that you or we would have in court may not be available in arbitration. Please read this Arbitration Clause and consult the rules of the arbitration organizations listed below for more information.

**Models: CCVS80, CCVS96, GCVC80, GMVC80, GCVC96, GCVM97, GMVC96, GMVM97, GMVS80, GMVS96, GC9C96, GD9S96, GD9T80, GD9T96, GDVM97, GDVT80, GDVT96, GM9C96, GC9C80, GM9C80, GC9S96, GM9S96, GCEC96, GCEC80, GMEC80, GCES96, GMEC96, GMES96, GR9S96, GR9T80, GR9T96, GRVM97, GRVT80, GRVT96, GRVS80, GRVS96, CDVS96**

5. **SMALL CLAIMS COURT OPTION: YOU MAY CHOOSE TO LITIGATE ANY DISPUTE BETWEEN YOU AND ANY OF US IN SMALL CLAIMS COURT, RATHER THAN IN ARBITRATION, IF THE DISPUTE MEETS ALL REQUIREMENTS TO BE HEARD IN SMALL CLAIMS COURT.**
6. **Governing Law:** For residents of the United States, the procedures and effect of the arbitration will be governed by the Federal Arbitration Act (9 U.S.C. § 1 et seq.) rather than by state law concerning arbitration. For residents of Canada, the procedures and effect of the arbitration will be governed by the applicable arbitration law of the province in which you purchased your unit. The law governing your substantive warranty rights and other claims will be the law of the state or province in which your unit was installed. Any court having jurisdiction may enter judgment on the arbitration award.
7. **Rules of the Arbitration:** If the amount in controversy is less than \$250,000, the arbitration will be decided by a single arbitrator. If the amount in controversy is greater than or equal to \$250,000, the arbitration will be decided by a panel of three arbitrators. The arbitrator(s) will be chosen pursuant to the rules of the administering arbitration organization. United States residents may choose JAMS (1920 Main Street, Ste. 300, Irvine, CA 92614, [www.jamsadr.com](http://www.jamsadr.com)) or, subject to our approval, any other arbitration organization. In addition, Canadian residents may choose the ADR Institute of Canada (234 Eglinton Ave. East, Suite 405, Toronto, Ontario, M4P 1K5, [www.amic.org](http://www.amic.org)). These organizations' rules can be obtained by contacting the organization or visiting its website. If the chosen arbitration organization's rules conflict with this Arbitration Clause, the provisions of this Arbitration Clause control. The award of the arbitrator(s) shall be final and binding on all parties.
8. **Location of the Arbitration Hearing:** Unless applicable law provides otherwise, the arbitration hearing for United States residents will be conducted in the federal judicial district in which you reside (in your hometown area) or, for Canadian residents, in the province in which you reside, and if you choose, will be in person.
9. **Costs of the Arbitration:** Each party is responsible for its own attorney, expert, and other costs and fees unless applicable law requires otherwise. Each party is also responsible for one-half of any costs and fees charged by the arbitration organization and arbitrator(s) to administer the arbitration to the maximum extent permitted by law or rule. Where permissible by law, the prevailing party may be required to reimburse the other party for the costs and fees of the arbitration organization and arbitrator(s) in whole or in part by decision of the arbitrator(s) at the discretion of the arbitrator(s).
10. **Survival and Enforceability of this Arbitration Clause:** This Arbitration Clause shall survive the expiration or termination, or any transfer, of the warranty on your unit. If any part of this Arbitration Clause, except waivers of class-action rights, is found to be unenforceable for any reason, the remainder of this clause and the warranty shall remain enforceable. If, in a case in which class-action allegations have been made, the waiver of class-action rights under this warranty is found to be unenforceable with respect to any part of the dispute, the parts of the dispute as to which the waiver of class-action rights have been found unenforceable will be severed and will proceed in court without reference or application of this Arbitration Clause. Any remaining parts will proceed in arbitration.



Air Conditioning & Heating

# INDOOR COILS



CAPTA – Cased with Internal TXV



CSCT – Cased with Internal TXV

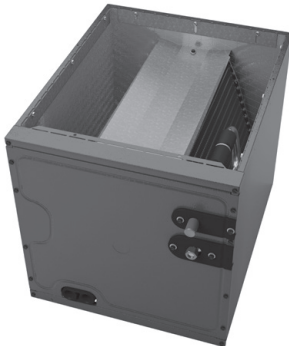

CAPFA cased

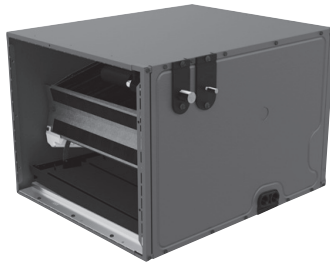

CHPTA – Cased with Internal TXV



CHPEA  
Horizontal "A" with EEV



CAPEA and CAHEA  
Cased with internal EEV

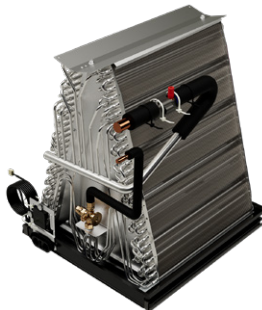

CAUTA  
Uncased with TXV



CAHEA  
Cased with internal EEV

CAPEA, CHPEA, CAPFA, CAPTA,  
CHPTA, CSCT, CAUTA AND CAHEA  
PAINTED UPFLOW/DOWNFLOW,  
HORIZONTAL "A" AND HORIZONTAL SLAB

**R32**

### Standard Features

- All-Aluminum evaporator coil
- Optimized for use with R-32 refrigerant including circuits and manifolds
- R-32 sensor designed for the life span of the coil
- CAPTA, CHPTA CAUTA models feature factory-installed thermal expansion valves for cooling and heat pump applications
- CSCT models feature a factory-installed thermal expansion valve for cooling applications
- CAPEA, CHPEA and CAHEA models feature:
  - Factory-installed electronic expansion valve (EEV) for precise refrigerant control
  - Compatibility with Daikin *One+* smart thermostat and other Daikin communicating equipment
  - Cooling and heat pump applications
  - Fault recall of six most recent faults
- CAPFA models feature optimized metering devices (piston)
- Standardized copper suction tube stub length
- Vertical and horizontal models available
- 21" depth for easier attic access
- CAPFA, CAPTA, CHPTA, CAPEA and CHPEA include single front access panel
- Foil-faced insulation covers the internal casing to reduce cabinet condensation
- Galvanized, leather grain-embossed finish
- Rust resistant, thermoplastic drain pans featuring a low water-retention design
- DecaBDE-free thermoplastic drain pan with secondary drain connections
- Drain pan rails designed to remove and reposition coils with ease without compromising structural integrity
- UV-resistant drain pan
- AHRI certified; ETL listed



**Note:** Do not use these coils on oil furnaces or any applications where the temperature on the drain pan may exceed 300° F. If these coils are applied with an oil furnace or another application where high temperatures threaten or jeopardize the durability of the drain pan, you must replace the factory-installed drain pan with a high-temperature drain pan. High-temperature drain pan kits are available as field-installed accessories.



\* Complete warranty details available from your local dealer or at [www.goodmanmfg.com](http://www.goodmanmfg.com). To receive the 10-Year Parts Limited Warranty, online registration must be completed within 60 days of installation. Online registration and some of the additional requirements are not required in Florida, California, or Québec. The duration of warranty coverage in Texas and Florida differs in some cases. Other limitations and exclusions apply; refer to complete warranty details for a full list of limitations and exclusions.



# CAPTA — CASED UPFLOW/DOWNFLOW INDOOR COILS

## SPECIFICATIONS

MODEL	CABINET DIMENSIONS			NOMINAL TONS	CONNECTION		SHIP WEIGHT (LBS)
	W	D	H		LIQUID	SUCTION	
CAPTA1818A3	14"	21"	18"	1½	⅜"	¼"	30
CAPTA1818B3	17½"	21"	18"	1½	⅜"	¼"	35
CAPTA2422A3	14"	21"	22"	1½ - 2	⅜"	¼"	37
CAPTA2422B3	17½"	21"	22"	1½ - 2	⅜"	¼"	40
CAPTA2422C3	21"	21"	22"	1½ - 2	⅜"	¼"	43
CAPTA3022A3	14"	21"	22"	2 - 2½	⅜"	¼"	37
CAPTA3022B3	17½"	21"	22"	2 - 2½	⅜"	¼"	40
CAPTA3022C3	21"	21"	22"	2 - 2½	⅜"	¼"	43
CAPTA3026B3	17½"	21"	26"	1½ - 2½	⅜"	⅝"	46
CAPTA3026C3	21"	21"	26"	1½ - 2½	⅜"	⅝"	51
CAPTA3626B3	17½"	21"	26"	2 - 3	⅜"	⅝"	48
CAPTA3626C3	21"	21"	26"	2 - 3	⅜"	⅝"	51
CAPTA4230C3	21"	21"	30"	2½ - 3½	⅜"	⅝"	66
CAPTA4230D3	24½"	21"	30"	2½ - 3½	⅜"	⅝"	70
CAPTA6030C3	21"	21"	30"	3½ - 5	⅜"	⅝"	66
CAPTA6030D3	24½"	21"	30"	3½ - 5	⅜"	⅝"	70
CAPTA6034C3	21"	21"	34"	4 - 5	⅜"	⅝"	77
CAPTA6034D3	24.5"	21"	34"	4 - 5	⅜"	⅝"	80

**Note:** For a properly matched system and piston sizing information, refer to Daikin piston kit chart of the corresponding Daikin outdoor unit.

## DIMENSIONS

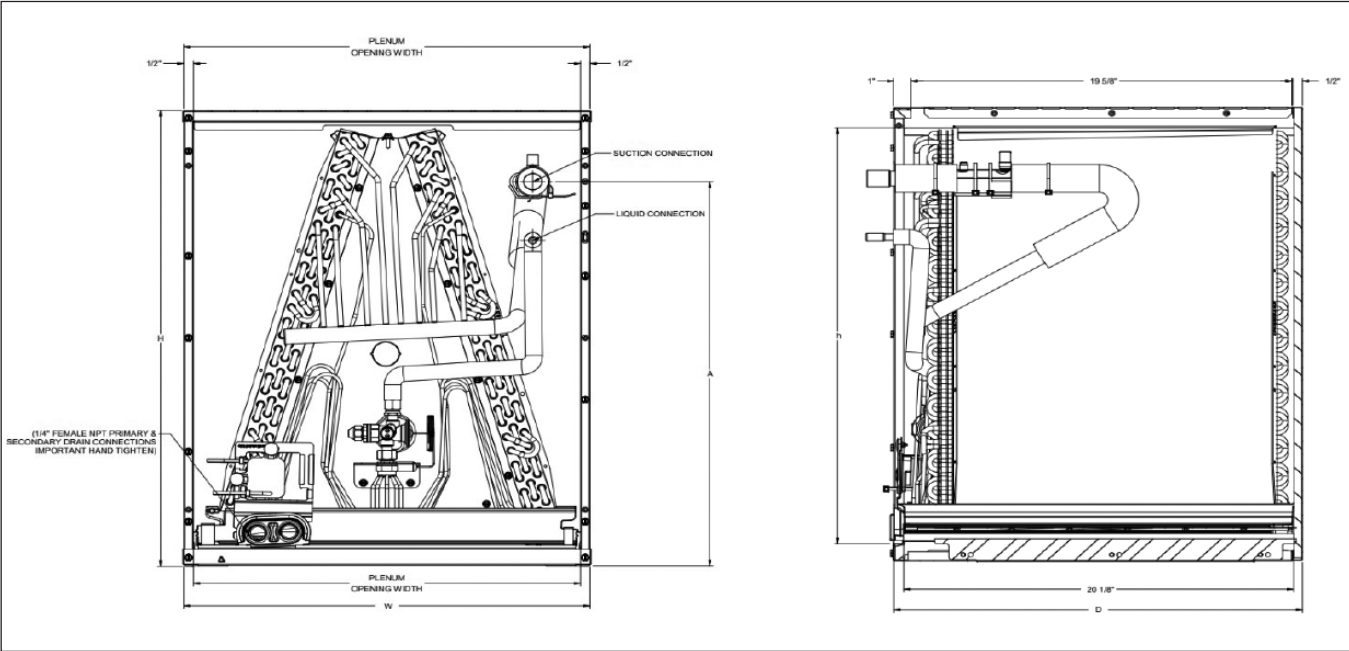

# CHPTA— CASED HORIZONTAL INDOOR COILS



## SPECIFICATIONS

MODEL	CABINET DIMENSIONS			NOMINAL TONS	CONNECTION		SHIP WEIGHT (LBS)
	W	D	H		LIQUID	SUCTION	
CHPTA1822A3	22"	21"	14"	1½	¾"	¾"	46
CHPTA1822B3	22"	21"	17½"	1½	¾"	¾"	50
CHPTA2426B3	26"	21"	17½"	1½ - 2	¾"	7⁄8"	55
CHPTA2426C3	26"	21"	21"	1½ - 2	¾"	7⁄8"	57
CHPTA3026B3	26"	21"	17½"	2 - 2½	¾"	7⁄8"	59
CHPTA3026C3	26"	21"	21"	2 - 2½	¾"	7⁄8"	62
CHPTA3630B3	30"	21"	17½"	2½ - 3	¾"	7⁄8"	66
CHPTA3630C3	30"	21"	21"	2½ - 3	¾"	7⁄8"	70
CHPTA4230C3	30"	21"	21"	2½ - 3½	¾"	7⁄8"	70
CHPTA4830C3	30"	21"	21"	3½ - 4	¾"	7⁄8"	78
CHPTA6030D3	30"	21"	24½"	4 - 5	¾"	7⁄8"	82

**Note:** For a properly matched system and piston sizing information, refer to Daikin piston kit chart of the corresponding Daikin outdoor unit.

## DIMENSIONS

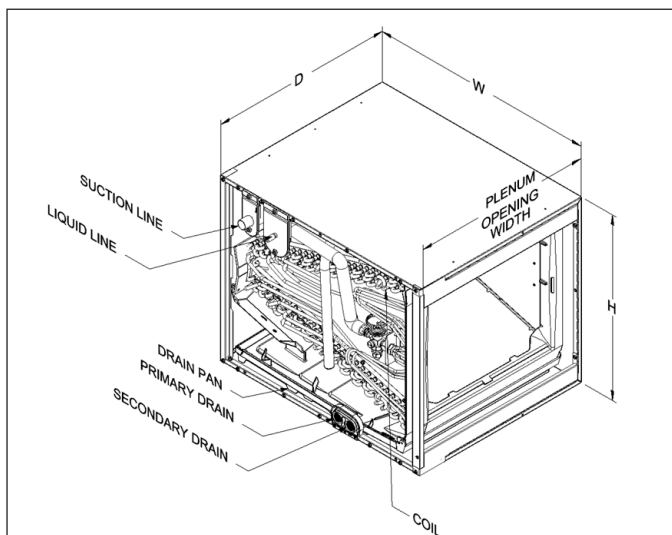
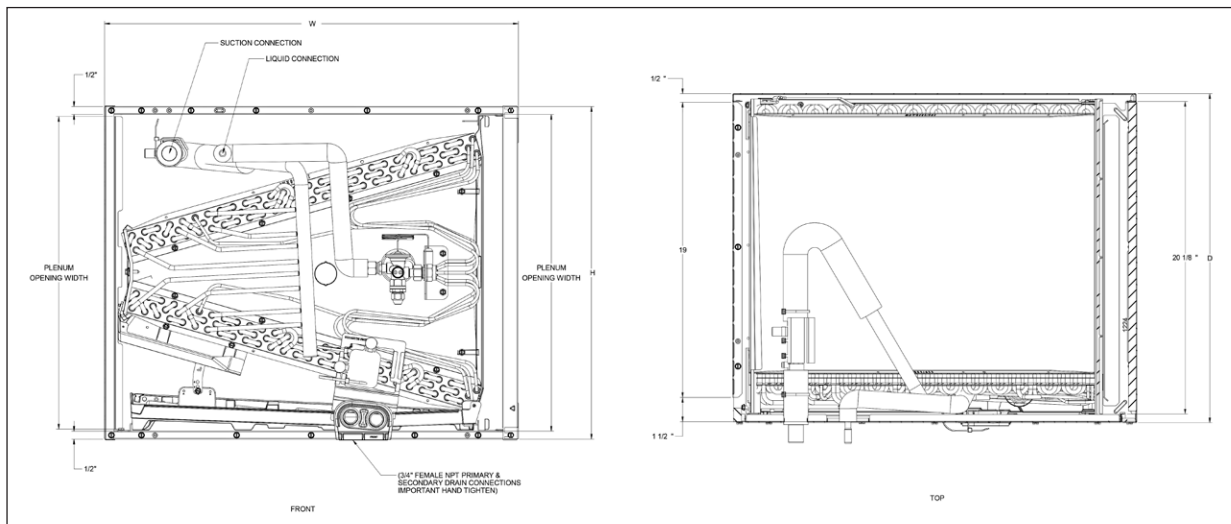

**CAPFA— CASED UPFLOW/DOWNFLOW INDOOR COILS**



**SPECIFICATIONS**

MODEL	CABINET DIMENSIONS				NOMINAL TONS	CONNECTION		SHIP WEIGHT (LBS)
	W	D	H	A		LIQUID	SUCTION	
CAPFA1818A3	14"	21"	18"	14"	1½	¾"	¾"	28
CAPFA1818B3	17½"	21"	18"	15½"	1½	¾"	¾"	34
CAPFA1818C3	21"	21"	18"	14"	1½	¾"	¾"	43
CAPFA2422A3	14"	21"	22"	18"	2	¾"	¾"	42
CAPFA2422B3	17½"	21"	22"	18"	2	¾"	¾"	42
CAPFA2422C3	21"	21"	22"	18"	2	¾"	¾"	42
CAPFA3022A3	14"	21"	22"	18"	2½	¾"	¾"	36
CAPFA3022B3	17½"	21"	22"	18"	2½	¾"	¾"	42
CAPFA3022C3	21"	21"	22"	18"	2½	¾"	¾"	42
CAPFA3022D3	24½"	21"	22"	18"	2½	¾"	¾"	53
CAPFA3626B3	17½"	21"	26"	22"	3	¾"	7⁄8"	46
CAPFA3626C3	21"	21"	26"	22"	3	¾"	7⁄8"	50
CAPFA3626D3	24½"	21"	26"	22"	3	¾"	7⁄8"	61
CAPFA4226B3	17½"	21"	26"	22"	3½	¾"	7⁄8"	46
CAPFA4226C3	21"	21"	26"	22"	3½	¾"	7⁄8"	50
CAPFA4226D3	24½"	21"	26"	22"	3½	¾"	7⁄8"	61
CAPFA6030C3	21"	21"	30"	26"	4	¾"	7⁄8"	66
CAPFA6030D3	24½"	21"	30"	26"	5	¾"	7⁄8"	69

**Note:** For a properly matched system and piston sizing information, refer to Daikin piston kit chart of the corresponding Daikin outdoor unit.

**DIMENSIONS**

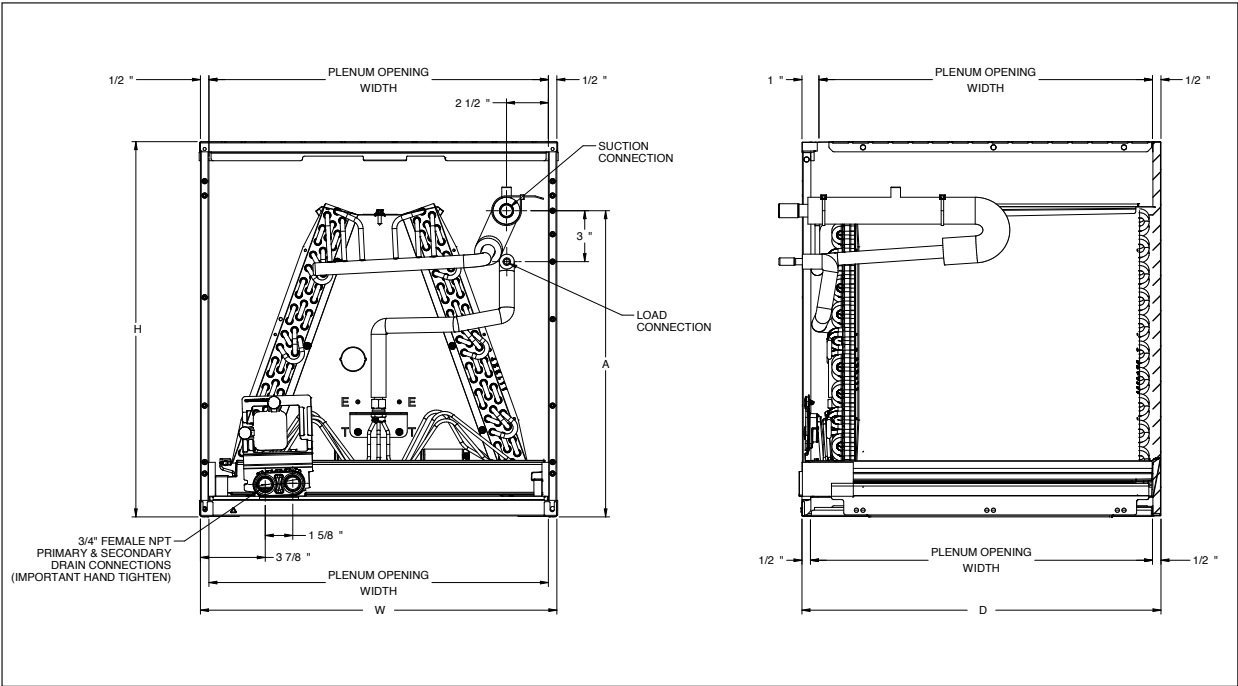

# CAPEA— CASED UPFLOW/DOWNFLOW INDOOR COILS



## SPECIFICATIONS

MODEL	CABINET DIMENSIONS			NOMINAL TONS	CONNECTION		SHIP WEIGHT (LBS)
	W	D	H		LIQUID	SUCTION	
CAPEA2418B3	17½"	21	18	2	5/16" or 3/8"	5/8" or 3/4"	43
CAPEA2418C3	21	21	18	2	5/16" or 3/8"	5/8" or 3/4"	45
CAPEA3022B3	17½"	21	22	2½	5/16" or 3/8"	3/4" or 7/8"	48
CAPEA3022C3	21	21	22	2½	5/16" or 3/8"	3/4" or 7/8"	51
CAPEA3626B3	17½"	21	26	3	5/16" or 3/8"	3/4" or 7/8"	54
CAPEA3626C3	21	21	26	3	5/16" or 3/8"	3/4" or 7/8"	57
CAPEA3626D3	24½"	21	26	3	5/16" or 3/8"	3/4" or 7/8"	62
CAPEA4830C3	21	21	30	4	3/8"	7/8" or 1½"	68
CAPEA4830D3	24½"	21	30	4	3/8"	7/8" or 1½"	70
CAPEA6030C3	21	21	30	5	3/8"	7/8" or 1½"	75
CAPEA6030D3	24½"	21	30	5	3/8"	7/8" or 1½"	78

**Note:** For a properly matched system and piston sizing information, refer to Daikin piston kit chart of the corresponding Daikin outdoor unit.

## DIMENSIONS

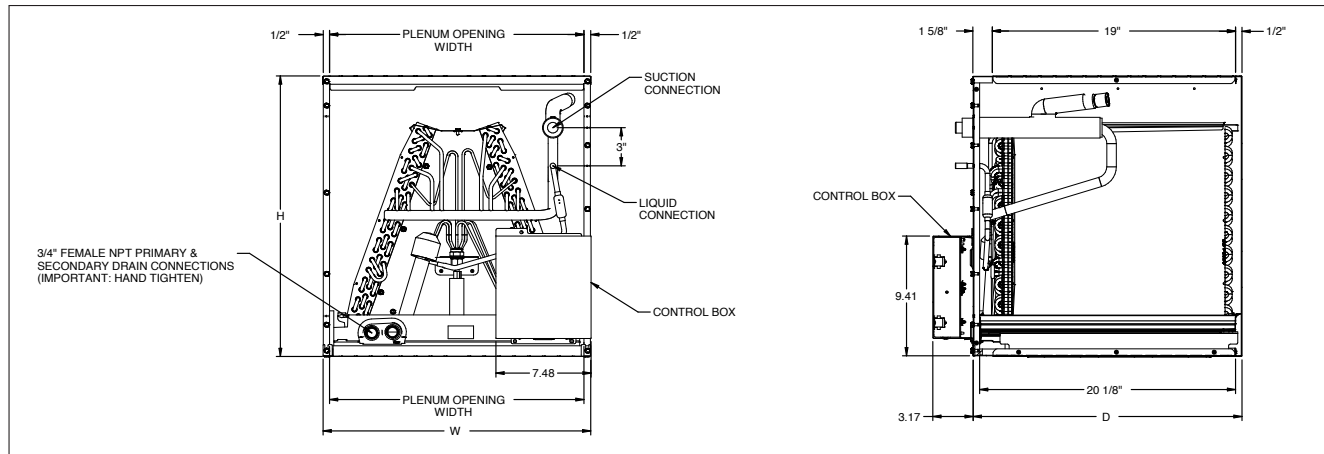

# CHPEA— CASED HORIZONTAL INDOOR COILS



## SPECIFICATIONS

MODEL	CABINET DIMENSIONS			NOMINAL TONS	CONNECTION		SHIP WEIGHT (LBS)
	W	D	H		LIQUID	SUCTION	
CHPEA2422B3	22"	21"	17½"	2	5/16" or 3/8"	5/8" or 3/4"	56
CHPEA3026B3	26"	21"	17½"	2½	5/16" or 3/8"	3/4" or 7/8"	63
CHPEA3026C3	26"	21"	21"	2½	5/16" or 3/8"	3/4" or 7/8"	67
CHPEA3626B3	26"	21"	17½"	3	5/16" or 3/8"	3/4" or 7/8"	68
CHPEA3626C3	26"	21"	21"	3	5/16" or 3/8"	3/4" or 7/8"	70
CHPEA4830C3	30"	21"	21"	4	3/8"	7/8" or 1½"	76
CHPEA4830D3	30"	21"	24½"	4	3/8"	7/8" or 1½"	78
CHPEA6030D3	30"	21"	21"	5	3/8"	7/8" or 1½"	76
CHPEA6030C3	30"	21"	24½"	5	3/8"	7/8" or 1½"	78

**Note:** For a properly matched system and piston sizing information, refer to Daikin piston kit chart of the corresponding Daikin outdoor unit.

## DIMENSIONS

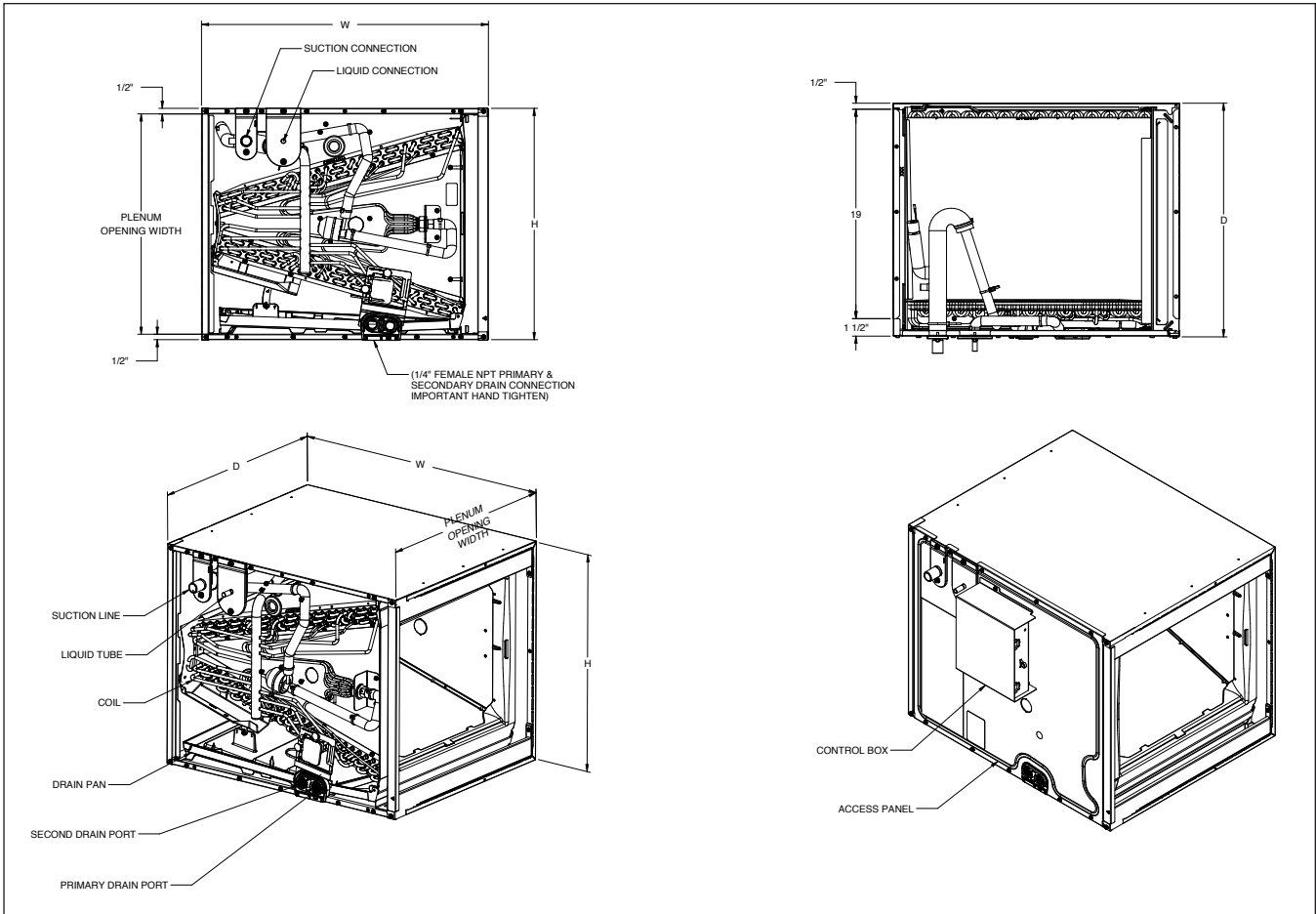

# CSCT— CASED HORIZONTAL SLAB INDOOR COILS



## SPECIFICATIONS

MODEL	CABINET DIMENSIONS			PLENUM OPENING		NOMINAL TONS	COIL DIMENSIONS		SERVICE VALVE		SHIP WEIGHT (LBS)
	W	D	H	W	H		W	H	LIQUID	SUCTION	
CSCT2412S3	25½"	12"	25"	16"	21"	1½-2	20"	24"	¾"	¾"	35
CSCT3012M3	33½"	12"	25"	24"	21"	2-2½	28"	24"	¾"	7⁄8"	42
CSCT3612L3	39½"	12"	25"	30"	21"	2½-3	34"	24"	¾"	7⁄8"	53
CSCT6012L3	39½"	12"	25"	30"	21"	4-5	34"	24"	¾"	7⁄8"	58

**Note:** For a properly matched system and piston sizing information, refer to Daikin piston kit chart of the corresponding Daikin outdoor unit.

## DIMENSIONS

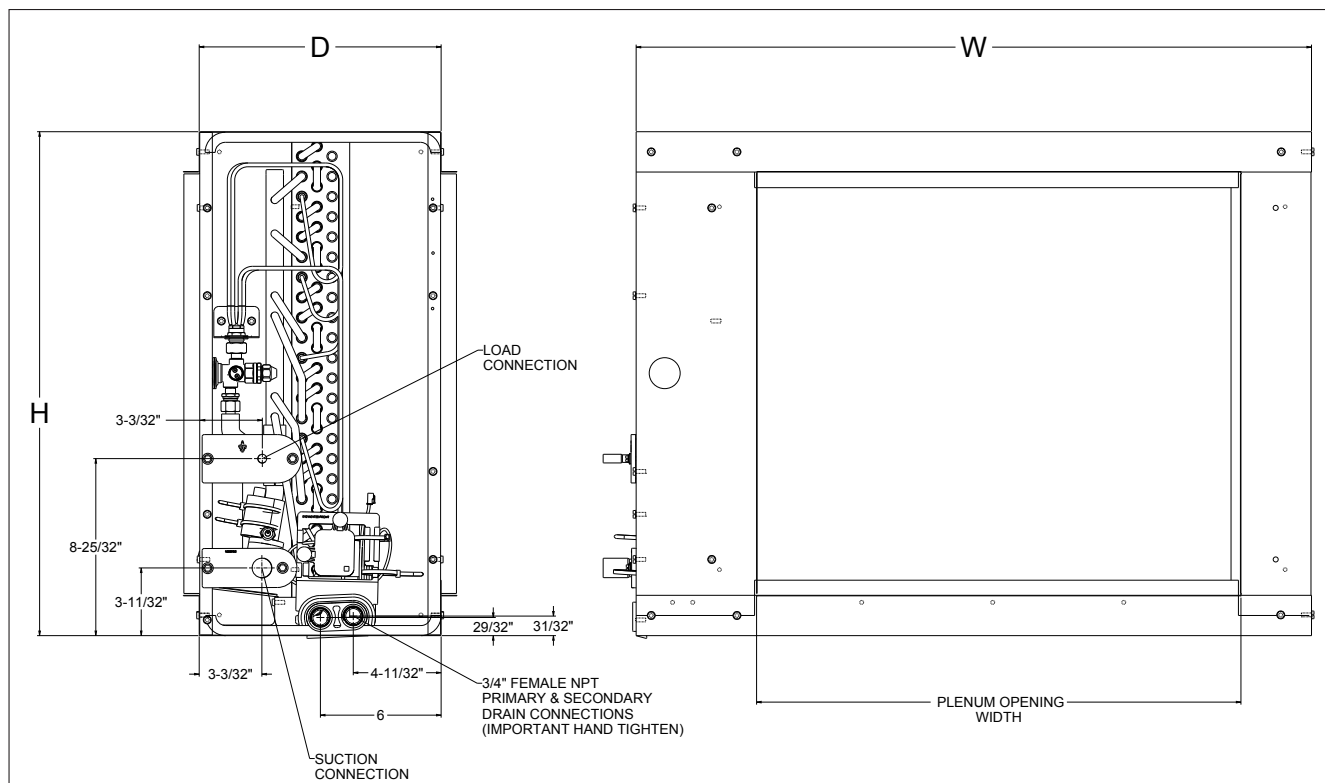

**CAUTA — Uncased with TXV**



**SPECIFICATIONS**

MODEL	CABINET DIMENSIONS			NOMINAL TONS	CONNECTION		SHIP WEIGHT (LBS)
	W	D	H		LIQUID	SUCTION	
CAUTA1818A3	13"	21½"	15"	1½	⅜"	¼"	22
CAUTA1818B3	16½"	21½"	15"	1½	⅜"	¼"	24
CAUTA2422A3	13"	21½"	18½"	1½ - 2	⅜"	¼"	25
CAUTA2422B3	16½"	21½"	18½"	1½ - 2	⅜"	¼"	28
CAUTA2422C3	20"	21½"	18½"	1½ - 2	⅜"	¼"	30
CAUTA3022A3	13"	21½"	18½"	2 - 2½	⅜"	¼"	25
CAUTA3022B3	16½"	21½"	18½"	2 - 2½	⅜"	¼"	28
CAUTA3022C3	20"	21½"	18½"	2 - 2½	⅜"	¼"	30
CAUTA3026B3	16.5"	21½"	22½"	1½ - 2½	⅜"	⅞"	30
CAUTA3026C3	20"	21½"	22½"	1½ - 2½	⅜"	⅞"	34
CAUTA3626B3	16½"	21½"	24½"	2 - 3	⅜"	⅞"	33
CAUTA3626C3	20"	21½"	23 <sup>9</sup> / <sub>10</sub> "	2 - 3	⅜"	⅞"	35
CAUTA4230C3	20"	21½"	27½"	2½ - 3½	⅜"	⅞"	38
CAUTA4230D3	23½"	21½"	27 <sup>1</sup> / <sub>10</sub> "	2½ - 3½	⅜"	⅞"	40
CAUTA6030C3	20"	21½"	27½"	3½ - 5	⅜"	⅞"	43
CAUTA6030D3	23½"	21½"	27½"	3½ - 5	⅜"	⅞"	46

**Note:** For a properly matched system and piston sizing information, refer to Daikin piston kit chart of the corresponding Daikin outdoor unit.

**DIMENSIONS**

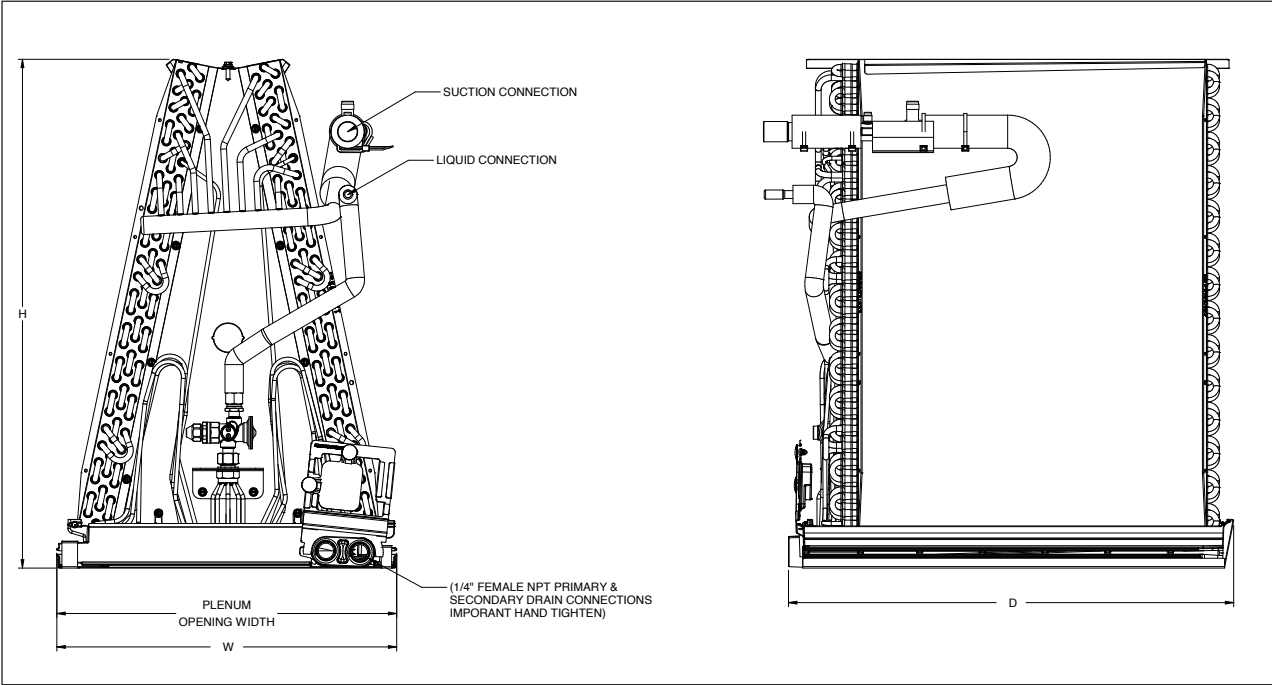

# CAHEA — MULTI-POSITION COLD CLIMATE INDOOR COILS



## SPECIFICATIONS

MODEL	CABINET DIMENSIONS			NOMINAL CAPACITY RANGE (TONS)	CONNECTION		SHIP WEIGHT (LBS)
	W	D	H		LIQUID	SUCTION	
CAHEA3630C3	21"	21"	30"	2, 3, 5	5/16" or 3/8"	3/4" or 7/8"	58

**Note:** For a properly matched system and piston sizing information, refer to Daikin piston kit chart of the corresponding Daikin outdoor unit.

## DIMENSIONS

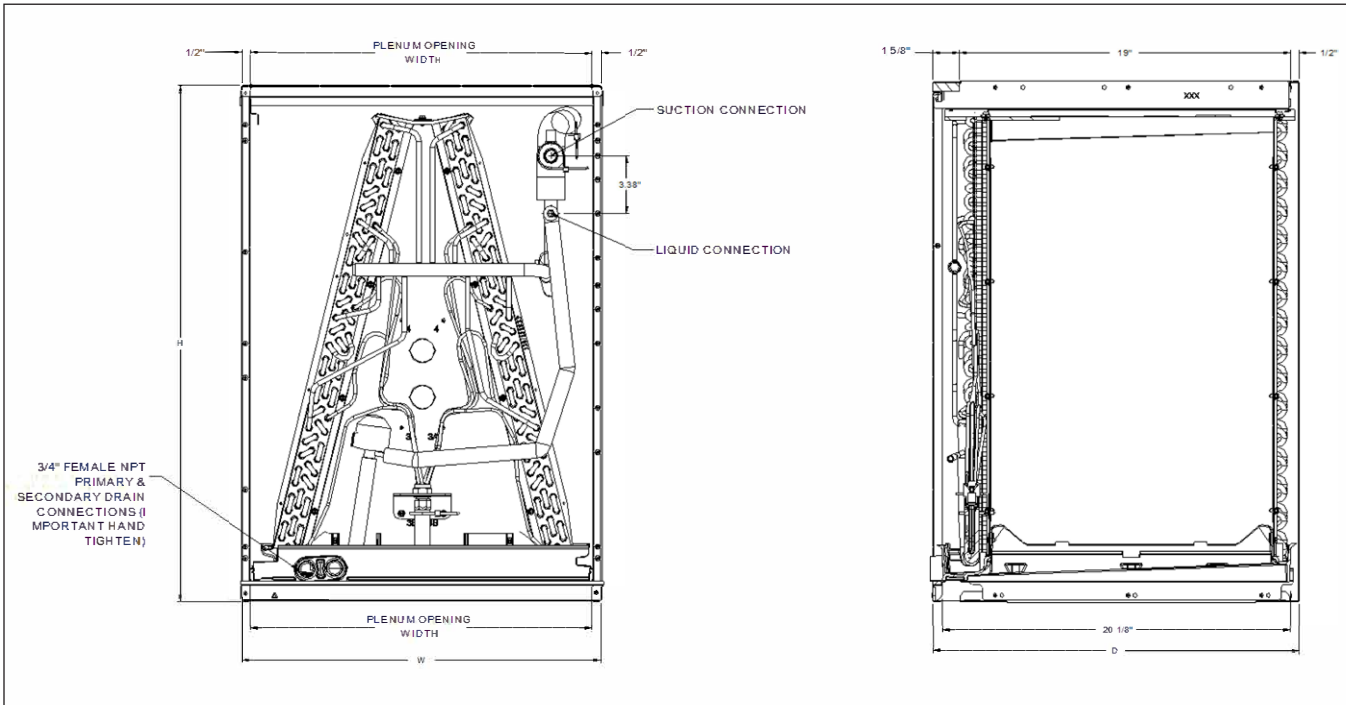

# AIRFLOW DATA FOR CAPTA

## AIR QUANTITY (SCFM) VS. PRESSURE DROP (IN. WC)

	SCFM	400	500	600	700	800	900	1000	1100	1200	1300	1400	1500	1600	1700	1800	1900	2000	2100	2200	
CAPTA1818A3**	Wet	0.080	0.135	0.205	0.275	0.346	0.422	0.516	0.620	0.715	-	-	-	-	-	-	-	-	-	-	-
	Dry	0.074	0.115	0.180	0.239	0.297	0.368	0.443	0.543	0.638	-	-	-	-	-	-	-	-	-	-	-
CAPTA1818B3**	Wet	0.067	0.106	0.165	0.215	0.261	0.317	0.372	0.425	0.482	-	-	-	-	-	-	-	-	-	-	-
	Dry	0.050	0.087	0.125	0.175	0.215	0.265	0.319	0.381	0.444	-	-	-	-	-	-	-	-	-	-	-
CAPTA2422A3**	Wet		0.108	0.150	0.195	0.250	0.310	0.379	0.460	0.543	0.625	0.730	-	-	-	-	-	-	-	-	-
	Dry		0.088	0.125	0.170	0.215	0.265	0.320	0.385	0.440	0.535	0.618	-	-	-	-	-	-	-	-	-
CAPTA2422B3**	Wet		0.090	0.130	0.150	0.220	0.250	0.310	0.369	0.436	0.508	0.584	-	-	-	-	-	-	-	-	-
	Dry		0.082	0.100	0.140	0.170	0.210	0.260	0.300	0.350	0.410	0.480	-	-	-	-	-	-	-	-	-
CAPTA2422C3**	Wet		0.091	0.110	0.139	0.172	0.205	0.245	0.285	0.335	0.387	0.437	-	-	-	-	-	-	-	-	-
	Dry		0.069	0.084	0.111	0.133	0.162	0.185	0.210	0.250	0.295	0.330	-	-	-	-	-	-	-	-	-
CAPTA3022A3**	Wet			0.150	0.195	0.250	0.310	0.379	0.460	0.543	0.625	0.730	-	-	-	-	-	-	-	-	-
	Dry			0.125	0.170	0.215	0.265	0.320	0.385	0.440	0.535	0.618	-	-	-	-	-	-	-	-	-
CAPTA3022B3**	Wet			0.130	0.150	0.220	0.250	0.310	0.369	0.436	0.508	0.584	-	-	-	-	-	-	-	-	-
	Dry			0.100	0.140	0.170	0.210	0.260	0.300	0.350	0.410	0.480	-	-	-	-	-	-	-	-	-
CAPTA3022C3**	Wet			0.110	0.139	0.172	0.205	0.245	0.285	0.335	0.387	0.437	-	-	-	-	-	-	-	-	-
	Dry			0.084	0.111	0.133	0.162	0.185	0.210	0.250	0.295	0.330	-	-	-	-	-	-	-	-	-
CAPTA3026B3**	Wet			0.115	0.150	0.190	0.229	0.270	0.310	0.365	0.420	0.475	-	-	-	-	-	-	-	-	-
	Dry			0.096	0.122	0.150	0.183	0.215	0.252	0.292	0.334	0.382	-	-	-	-	-	-	-	-	-
CAPTA3026C3**	Wet			0.090	0.110	0.140	0.170	0.200	0.240	0.280	0.320	0.370	-	-	-	-	-	-	-	-	-
	Dry			0.080	0.100	0.120	0.150	0.180	0.210	0.240	0.260	0.300	-	-	-	-	-	-	-	-	-
CAPTA3626B3**	Wet					0.134	0.167	0.204	0.245	0.290	0.338	0.389	0.444	0.485	-	-	-	-	-	-	-
	Dry					0.127	0.157	0.190	0.229	0.269	0.316	0.360	0.415	0.450	-	-	-	-	-	-	-
CAPTA3626C3**	Wet					0.100	0.120	0.150	0.180	0.210	0.240	0.280	0.310	0.360	-	-	-	-	-	-	-
	Dry					0.080	0.100	0.130	0.150	0.170	0.200	0.230	0.270	0.300	-	-	-	-	-	-	-
CAPTA4230C3**	Wet							0.130	0.150	0.180	0.210	0.250	0.280	0.310	0.340	0.378	0.414	-	-	-	-
	Dry							0.110	0.132	0.156	0.181	0.208	0.237	0.270	0.300	0.335	0.372	-	-	-	-
CAPTA4230D3**	Wet							0.120	0.140	0.160	0.190	0.220	0.250	0.280	0.310	0.350	0.380	-	-	-	-
	Dry							0.091	0.109	0.127	0.147	0.160	0.190	0.210	0.230	0.260	0.280	-	-	-	-
CAPTA6030C3**	Wet							0.150	0.174	0.210	0.240	0.270	0.310	0.350	0.400	0.440	0.490	0.540	0.600	0.660	-
	Dry							0.133	0.160	0.190	0.210	0.250	0.280	0.320	0.350	0.390	0.440	0.480	0.530	0.590	-
CAPTA6030D3**	Wet							0.150	0.180	0.210	0.230	0.270	0.300	0.340	0.380	0.430	0.477	0.520	-	-	-
	Dry							0.120	0.140	0.160	0.190	0.210	0.230	0.260	0.290	0.320	0.350	0.380	-	-	-
CAPTA6034C3**	Wet							0.140	0.160	0.190	0.220	0.260	0.300	0.340	0.380	0.420	0.460	0.510	0.560	0.610	-
	Dry							0.120	0.140	0.170	0.200	0.230	0.260	0.300	0.330	0.360	0.400	0.430	0.480	0.520	-
CAPTA6034D3**	Wet							0.120	0.130	0.150	0.180	0.200	0.220	0.250	0.280	0.310	0.340	0.380	0.410	0.450	-
	Dry							0.090	0.100	0.120	0.140	0.160	0.180	0.200	0.220	0.250	0.280	0.310	0.340	0.380	0.410

# AIRFLOW DATA FOR CHPTA

## AIR QUANTITY (SCFM) VS. PRESSURE DROP (IN. WC)

	SCFM	400	500	600	700	800	900	1000	1100	1200	1300	1400	1500	1600	1700	1800	1900	2000	2100	2200		
<b>CHPTA1822A3**</b>	Wet	0.095	0.151	0.215	0.284	0.354	0.429	0.519	0.601													
	Dry	0.064	0.094	0.144	0.199	0.284	0.353	0.431	0.513													
<b>CHPTA1822B3**</b>	Wet	0.090	0.120	0.140	0.190	0.250	0.310	0.390	0.460													
	Dry	0.080	0.110	0.130	0.180	0.230	0.290	0.360	0.430													
<b>CHPTA2426B3**</b>	Wet		0.130	0.150	0.180	0.204	0.255	0.304	0.365	0.419	0.468											
	Dry		0.100	0.120	0.150	0.170	0.210	0.240	0.290	0.330	0.410											
<b>CHPTA2426C3**</b>	Wet		0.110	0.140	0.160	0.180	0.200	0.230	0.270	0.320	0.370											
	Dry		0.090	0.110	0.130	0.150	0.190	0.220	0.260	0.300	0.350											
<b>CHPTA3026B3**</b>	Wet			0.110	0.150	0.180	0.230	0.280	0.320	0.370	0.430	0.490										
	Dry			0.120	0.140	0.170	0.210	0.250	0.290	0.340	0.400	0.460										
<b>CHPTA3026C3**</b>	Wet			0.100	0.130	0.150	0.170	0.200	0.230	0.260	0.300	0.340										
	Dry			0.060	0.080	0.110	0.130	0.150	0.174	0.198	0.229	0.259										
<b>CHPTA3630B3**</b>	Wet			0.150	0.187	0.229	0.279	0.323	0.372	0.430	0.465											
	Dry			0.128	0.153	0.191	0.237	0.285	0.330	0.377	0.428											
<b>CHPTA3630C3**</b>	Wet			0.140	0.175	0.205	0.245	0.285	0.325	0.365	0.410											
	Dry			0.086	0.105	0.135	0.155	0.185	0.210	0.245	0.279											
<b>CHPTA4230C3**</b>	Wet			0.140	0.175	0.205	0.245	0.285	0.325	0.365	0.410											
	Dry			0.086	0.105	0.135	0.155	0.185	0.210	0.245	0.279											
<b>CHPTA4830C3**</b>	Wet							0.210	0.250	0.304	0.352	0.402	0.457	0.510	0.570	0.630	0.693	0.761	0.831	0.894		
	Dry							0.163	0.194	0.226	0.263	0.297	0.337	0.381	0.420	0.470	0.520	0.580	0.630	0.690		
<b>CHPTA6030D3**</b>	Wet							0.161	0.189	0.221	0.254	0.292	0.332	0.370	0.413	0.461	0.502					
	Dry							0.140	0.160	0.190	0.220	0.250	0.283	0.314	0.351	0.389	0.402					

# AIRFLOW DATA FOR CAPFA

## AIR QUANTITY (SCFM) VS. PRESSURE DROP (IN. WC)

	SCFM	400	500	600	700	800	900	1000	1100	1200
CAPFA1818A3**	Wet	0.080	0.135	0.205	0.275	0.346	0.422	0.516	0.620	0.715
	Dry	0.074	0.115	0.180	0.239	0.297	0.368	0.443	0.543	0.638
CAPFA1818B3**	Wet	0.067	0.106	0.165	0.215	0.261	0.317	0.372	0.425	0.482
	Dry	0.050	0.087	0.125	0.175	0.215	0.265	0.319	0.381	0.444
CAPFA1818C3**	Wet	0.089	0.124	0.162	0.211	0.261	0.305	0.366	0.433	0.504
	Dry	0.070	0.101	0.132	0.171	0.205	0.253	0.300	0.350	0.400
	SCFM		500	600	700	800	900	1000	1100	1200
CAPFA2422A3**	Wet		0.126	0.180	0.220	0.280	0.340	0.410	0.500	0.580
	Dry		0.088	0.125	0.170	0.215	0.265	0.320	0.385	0.440
CAPFA2422B3**	Wet		0.117	0.167	0.211	0.257	0.309	0.360	0.430	0.540
	Dry		0.082	0.100	0.140	0.170	0.210	0.260	0.300	0.350
CAPFA2422C3**	Wet			0.135	0.165	0.195	0.235	0.277	0.324	0.365
	Dry			0.107	0.129	0.154	0.183	0.214	0.242	0.278
	SCFM		600	700	800	900	1000	1100	1200	1300
CAPFA3022A3**	Wet		0.150	0.195	0.250	0.310	0.379	0.460	0.543	0.625
	Dry		0.125	0.170	0.215	0.265	0.320	0.385	0.440	0.535
CAPFA3022B3**	Wet		0.130	0.150	0.220	0.250	0.310	0.369	0.436	0.508
	Dry		0.100	0.140	0.170	0.210	0.260	0.300	0.350	0.410
CAPFA3022C3**	Wet		0.110	0.139	0.172	0.205	0.245	0.285	0.335	0.387
	Dry		0.084	0.111	0.133	0.162	0.185	0.210	0.250	0.295
CAPFA3022D3**	Wet			0.135	0.165	0.198	0.230	0.272	0.312	0.361
	Dry			0.110	0.135	0.165	0.190	0.220	0.255	0.290
	SCFM		600	700	800	900	1000	1100	1200	1300
CAPFA3626B3**	Wet			0.190	0.229	0.270	0.310	0.365	0.420	0.475
	Dry			0.127	0.157	0.190	0.229	0.269	0.316	0.360
CAPFA3626C3**	Wet			0.140	0.170	0.200	0.240	0.280	0.320	0.370
	Dry			0.080	0.100	0.130	0.150	0.170	0.200	0.230
CAPFA3626D3**	Wet				0.188	0.226	0.263	0.307	0.359	
	Dry				0.105	0.131	0.157	0.183	0.210	
	SCFM			800	900	1000	1100	1200	1300	1400
CAPFA4226B3**	Wet				0.211	0.255	0.299	0.345	0.395	0.450
	Dry				0.180	0.217	0.255	0.297	0.342	0.393
CAPFA4226C3**	Wet				0.176	0.208	0.243	0.281	0.321	0.364
	Dry				0.138	0.162	0.187	0.215	0.244	0.276
CAPFA4226D3**	Wet				0.162	0.186	0.211	0.236	0.262	0.291
	Dry				0.105	0.131	0.157	0.183	0.210	0.237
	SCFM				1000	1100	1200	1300	1400	1500
CAPFA6030C3**	Wet				0.150	0.174	0.210	0.240	0.270	0.310
	Dry				0.133	0.160	0.190	0.210	0.250	0.280
CAPFA6030D3**	Wet				0.150	0.180	0.210	0.230	0.270	0.300
	Dry				0.120	0.140	0.160	0.190	0.210	0.230
	SCFM				1900	2000	2100	2200		
CAPFA6030C3**	Wet				0.490	0.540	0.600	0.660		
	Dry				0.440	0.480	0.530	0.590		
CAPFA6030D3**	Wet				0.477	0.520	0.570	0.620		
	Dry				0.430	0.470	0.520	0.570		



# AIRFLOW DATA FOR CHPEA

## AIR QUANTITY (SCFM) VS. PRESSURE DROP (IN. WC)

		300	400	500	600	700	800	900	1000	1100	1200	1300	1400	1500	1600	1700	1800	1900	2000	
<b>CHPEA2422B3</b>	Wet	0.057	0.103	0.158	0.22	0.291	0.371	0.453	0.532	0.625	0.697									
	Dry	0.027	0.052	0.087	0.131	0.175	0.225	0.279	0.346	0.416	0.491									
<b>CHPEA3026B3</b>	Wet	0.033	0.060	0.092	0.131	0.173	0.220	0.273	0.331	0.400	0.469	0.540	0.621	0.696						
	Dry	0.024	0.042	0.064	0.095	0.126	0.158	0.194	0.236	0.283	0.335	0.389	0.444	0.501						
<b>CHPEA3026C3</b>	Wet	0.032	0.061	0.087	0.119	0.148	0.184	0.222	0.277	0.323	0.361	0.415	0.468	0.500						
	Dry	0.038	0.052	0.068	0.084	0.107	0.134	0.165	0.192	0.244	0.284	0.330	0.380	0.432						
<b>CHPEA3626B3</b>	Wet	0.041	0.064	0.092	0.132	0.169	0.205	0.252	0.303	0.357	0.415	0.480	0.549	0.621						
	Dry	0.028	0.048	0.072	0.099	0.131	0.166	0.207	0.251	0.299	0.353	0.412	0.474	0.540						
<b>CHPEA3626C3</b>	Wet	0.040	0.061	0.083	0.110	0.141	0.171	0.195	0.233	0.272	0.314	0.357	0.401	0.444						
	Dry	0.025	0.036	0.052	0.069	0.088	0.106	0.126	0.155	0.186	0.221	0.255	0.286	0.326						
<b>CHPEA4830C3</b>	Wet	0.042	0.071	0.097	0.128	0.154	0.194	0.230	0.260	0.300	0.343	0.390	0.433	0.483	0.529	0.589	0.627	0.676	0.730	
	Dry	0.019	0.031	0.044	0.059	0.077	0.099	0.123	0.153	0.181	0.211	0.247	0.283	0.321	0.362	0.404	0.451	0.496	0.546	
<b>CHPEA4830D3</b>	Wet	0.036	0.058	0.081	0.112	0.143	0.171	0.204	0.238	0.277	0.319	0.363	0.410	0.447	0.491	0.537	0.582	0.618	0.662	
	Dry	0.016	0.024	0.034	0.047	0.061	0.077	0.095	0.114	0.135	0.156	0.182	0.208	0.236	0.268	0.300	0.332	0.366	0.400	
<b>CHPEA6030C3</b>	Wet	0.043	0.069	0.105	0.148	0.188	0.226	0.265	0.312	0.366	0.428	0.489	0.548	0.605	0.654	0.700	0.760	0.820	0.860	
	Dry	0.019	0.031	0.044	0.059	0.077	0.099	0.123	0.153	0.181	0.211	0.247	0.283	0.321	0.362	0.404	0.451	0.496	0.546	
<b>CHPEA6030D3</b>	Wet	0.019	0.039	0.068	0.096	0.126	0.154	0.205	0.253	0.305	0.347	0.406	0.453	0.500	0.534	0.588	0.632	0.677	0.729	
	Dry	0.016	0.024	0.034	0.047	0.061	0.077	0.095	0.114	0.135	0.156	0.182	0.208	0.236	0.268	0.300	0.332	0.366	0.400	

# AIRFLOW DATA FOR CSCT

## AIR QUANTITY (SCFM) VS. PRESSURE DROP (IN. WC)

	SCFM	500	600	700	800	900	1000	1100	1200	1300	1400	1500	1600	1700	1800	1900	2000	2100	2200	
<b>CSCT2412S3</b>	Wet	0.104	0.143	0.176	0.212	0.255	0.292	0.321	0.344											
	Dry	0.048	0.067	0.086	0.108	0.132	0.159	0.186	0.206											
<b>CSCT3012M3</b>	Wet	---	---	0.062	0.076	0.092	0.109	0.131	0.156	0.186	0.209									
	Dry	---	---	0.032	0.043	0.055	0.068	0.082	0.099	0.114	0.131									
<b>CSCT3612L3</b>	Wet	---	---	---	0.045	0.063	0.081	0.099	0.116	0.132	0.148	0.166	0.183	0.202	0.220	0.236	0.259	0.278	0.291	
	Dry	---	---	---	0.039	0.051	0.064	0.077	0.092	0.105	0.121	0.138	0.150	0.175	0.191	0.214	0.230	0.251	0.262	
<b>CSCT6012L3</b>	Wet	---	---	---	0.051	0.068	0.085	0.103	0.120	0.137	0.154	0.173	0.192	0.212	0.233	0.255	0.278	0.299	0.319	
	Dry	---	---	---	0.043	0.056	0.069	0.084	0.099	0.115	0.132	0.149	0.167	0.185	0.207	0.227	0.249	0.272	0.282**	

\*\* Maximum SCFM=2146

# AIRFLOW DATA FOR CAUTA

## AIR QUANTITY (SCFM) VS. PRESSURE DROP (IN. WC)

	SCFM	400	500	600	700	800	900	1000	1100	1200	1300	1400	1500	1600	1700	1800	1900	2000	2100	2200	
CAUTA1818A3**	Wet	0.080	0.135	0.205	0.275	0.346	0.422	0.516	0.620	0.715	-	-	-	-	-	-	-	-	-	-	-
	Dry	0.074	0.115	0.180	0.239	0.297	0.368	0.443	0.543	0.638	-	-	-	-	-	-	-	-	-	-	-
	Wet	0.067	0.106	0.165	0.215	0.261	0.317	0.372	0.425	0.482	-	-	-	-	-	-	-	-	-	-	-
CAUTA1818B3**	Dry	0.050	0.087	0.125	0.175	0.215	0.265	0.319	0.381	0.444	-	-	-	-	-	-	-	-	-	-	-
	Wet	0.108	0.150	0.195	0.250	0.310	0.379	0.460	0.543	0.625	-	-	-	-	-	-	-	-	-	-	-
	Dry	0.088	0.125	0.170	0.215	0.265	0.320	0.385	0.440	0.535	-	-	-	-	-	-	-	-	-	-	-
CAUTA2422B3**	Wet	0.090	0.130	0.150	0.220	0.250	0.310	0.369	0.436	0.508	-	-	-	-	-	-	-	-	-	-	-
	Dry	0.082	0.100	0.140	0.170	0.210	0.260	0.300	0.350	0.410	-	-	-	-	-	-	-	-	-	-	-
	Wet	0.091	0.110	0.139	0.172	0.205	0.245	0.285	0.335	0.387	-	-	-	-	-	-	-	-	-	-	-
CAUTA2422C3**	Dry	0.069	0.084	0.111	0.133	0.162	0.185	0.210	0.250	0.295	-	-	-	-	-	-	-	-	-	-	-
	Wet	0.150	0.195	0.250	0.310	0.379	0.460	0.543	0.625	0.730	-	-	-	-	-	-	-	-	-	-	-
	Dry	0.125	0.170	0.215	0.265	0.320	0.385	0.440	0.535	0.618	-	-	-	-	-	-	-	-	-	-	-
CAUTA3022A3**	Wet	0.130	0.150	0.220	0.250	0.310	0.369	0.436	0.508	0.584	-	-	-	-	-	-	-	-	-	-	-
	Dry	0.100	0.140	0.170	0.210	0.260	0.300	0.350	0.410	0.480	-	-	-	-	-	-	-	-	-	-	-
	Wet	0.110	0.139	0.172	0.205	0.245	0.285	0.335	0.387	0.437	-	-	-	-	-	-	-	-	-	-	-
CAUTA3022C3**	Dry	0.084	0.111	0.133	0.162	0.185	0.210	0.250	0.295	0.330	-	-	-	-	-	-	-	-	-	-	-
	Wet	0.115	0.150	0.190	0.229	0.270	0.310	0.365	0.420	0.475	-	-	-	-	-	-	-	-	-	-	-
	Dry	0.096	0.122	0.150	0.183	0.215	0.252	0.292	0.334	0.382	-	-	-	-	-	-	-	-	-	-	-
CAUTA3026C3**	Wet	0.090	0.110	0.140	0.170	0.200	0.240	0.280	0.320	0.370	-	-	-	-	-	-	-	-	-	-	-
	Dry	0.080	0.100	0.120	0.150	0.180	0.210	0.240	0.260	0.300	-	-	-	-	-	-	-	-	-	-	-
	Wet	0.100	0.120	0.150	0.180	0.210	0.240	0.280	0.320	0.360	-	-	-	-	-	-	-	-	-	-	-
CAUTA3626C3**	Dry	0.080	0.100	0.130	0.150	0.170	0.200	0.230	0.270	0.300	-	-	-	-	-	-	-	-	-	-	-
	Wet	0.134	0.167	0.204	0.245	0.290	0.338	0.389	0.444	0.485	-	-	-	-	-	-	-	-	-	-	-
	Dry	0.127	0.157	0.190	0.229	0.269	0.316	0.360	0.415	0.450	-	-	-	-	-	-	-	-	-	-	-
CAUTA4230C3**	Wet	0.100	0.120	0.150	0.180	0.210	0.240	0.280	0.310	0.360	-	-	-	-	-	-	-	-	-	-	-
	Dry	0.080	0.100	0.130	0.150	0.170	0.200	0.230	0.270	0.300	-	-	-	-	-	-	-	-	-	-	-
	Wet	0.091	0.109	0.127	0.147	0.160	0.190	0.220	0.250	0.280	-	-	-	-	-	-	-	-	-	-	-
CAUTA4230D3**	Dry	0.100	0.120	0.150	0.180	0.210	0.240	0.280	0.310	0.360	-	-	-	-	-	-	-	-	-	-	-
	Wet	0.150	0.174	0.210	0.240	0.270	0.310	0.350	0.400	0.440	-	-	-	-	-	-	-	-	-	-	-
	Dry	0.133	0.160	0.190	0.210	0.250	0.280	0.320	0.350	0.390	-	-	-	-	-	-	-	-	-	-	-
CAUTA6030C3**	Wet	0.100	0.120	0.140	0.160	0.190	0.220	0.250	0.280	0.320	-	-	-	-	-	-	-	-	-	-	-
	Dry	0.080	0.100	0.120	0.140	0.160	0.190	0.220	0.250	0.280	-	-	-	-	-	-	-	-	-	-	-
	Wet	0.150	0.180	0.210	0.230	0.270	0.300	0.340	0.380	0.430	-	-	-	-	-	-	-	-	-	-	-
CAUTA6030D3**	Dry	0.120	0.140	0.160	0.190	0.210	0.230	0.270	0.300	0.340	-	-	-	-	-	-	-	-	-	-	-
	Wet	0.150	0.180	0.210	0.230	0.270	0.300	0.340	0.380	0.430	-	-	-	-	-	-	-	-	-	-	-
	Dry	0.120	0.140	0.160	0.190	0.210	0.230	0.270	0.300	0.340	-	-	-	-	-	-	-	-	-	-	-

## AIRFLOW DATA FOR CAHEA

### AIR QUANTITY (SCFM) VS. PRESSURE DROP (IN. WC)

	SCFM	700	800	900	1000	1100	1200	1300	1400	1500	1600	1700	1800	1900	2000	2100	2200
<b>CAHEA3630C3</b>	Wet	0.088	0.115	0.142	0.171	0.200	0.232	0.272	0.326	0.376	0.424	0.476	0.523	0.576	0.625	0.670	0.725
	Dry	0.070	0.089	0.109	0.131	0.156	0.182	0.210	0.240	0.274	0.306	0.344	0.383	0.423	0.469	0.512	0.561

## ACCESSORIES

### HIGH-TEMP DRAIN PAN KITS FOR CAPFA, CAPTA & CAUTA

DRAIN PAN KITS	FURNACE SIZE
HTP7-A	14" Furnaces
<i>HTP7-B - coming soon</i>	17½" Furnaces
HTP7-C	21" Furnaces
HTP7-D	24½" Furnaces

### DRAIN PAN INSULATION KITS FOR CAPFA, CAPTA, CAPEA & CAUTA

KIT NUMBER	CABINET WIDTH
DPICX-AB	14"
DPICX-BB	17½"
DPICX-CB	21"
DPICX-DB	24½"
DPICX-DC (Use only for CAPTA6030D3, CAPTA6034D3, CAPFA6030D3 and CAUTA6030D3)	24½"

### UV-C PART NUMBERS

MODELS	LAMP
UC18S15-24	UCP-16013
UC18S15-24B	UCP-16012

### HORIZONTAL RIGHT COIL ACCESSORY FOR HIGH HUMIDITY ENVIRONMENT FOR CHPTA & CHPEA

DRAIN PAN KITS	FURNACE SIZE
HHCMK01	All Horizontal cabinets

### R32 ACCESSORY KIT FOR NON-A2L FURNACE FOR CAPFA, CAPTA, CHPTA, CSCT, CAPEA, CHPEA, CSCT & CAUTA

KIT NUMBER	FURNACE TYPE
0230K00044	Non-A2L furnaces

### R32 ZONING ACCESSORY KIT FOR CAPFA, CAPTA, CHPTA, CSCT, CAPEA, CHPEA & CAUTA

KIT NUMBER	MODELS
0230K00007	All CAPTA, CHPTA, CHPEA, CAPEA, CAPFA, CAUTA and CSCT

### DOWNFLOW KITS FOR CAPEA

KIT NUMBER	MODELS
DFKE-02	CAPEA4830C3, D3 CAPEA6030C3, D3

### ACCESSORIES FOR CAHEA

HHK0011	High Humidity Kit
CMK-0017	Condensate Management Kit
DFKE-02	Downflow Kit
0270K00063	Horizontal Installation Kit

0154D20003S*	Gasket for sealing the cased coil and modular blower joint
--------------	--

### FILLER PLATES FOR NON STRAIGHT COIL-FURNACE MATCHUP CAPFA, CAPTA, CHPTA, CAPEA & CHPEA

KIT NUMBER
FPKT01

