

INSTRUCTION MANUAL FOR DL-4021

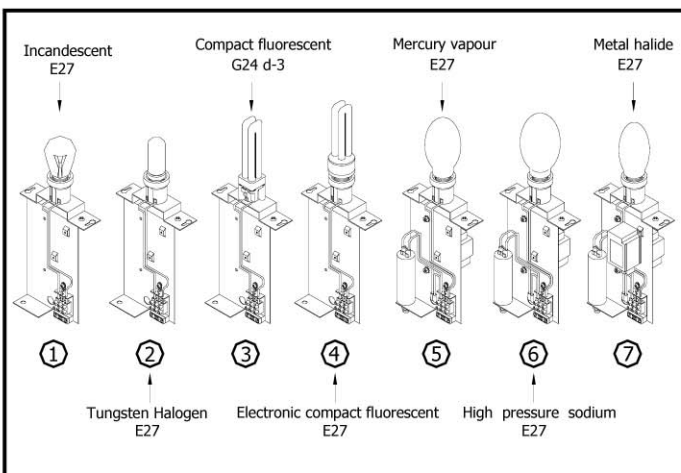

IP54

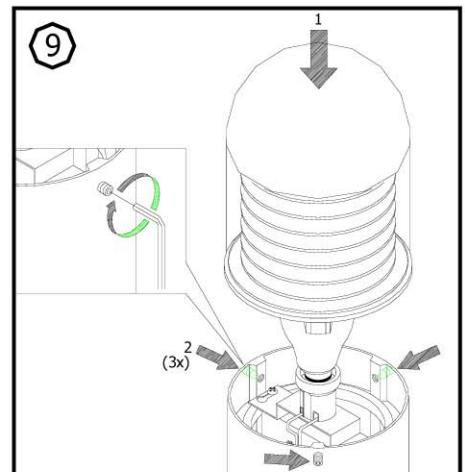
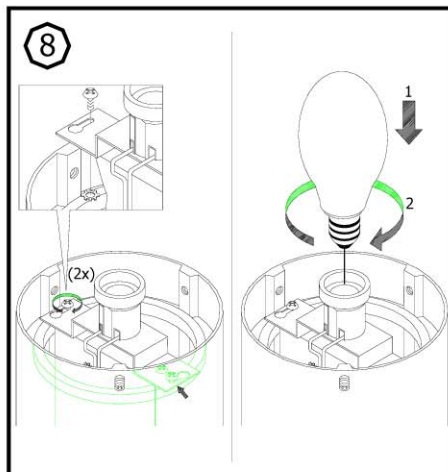
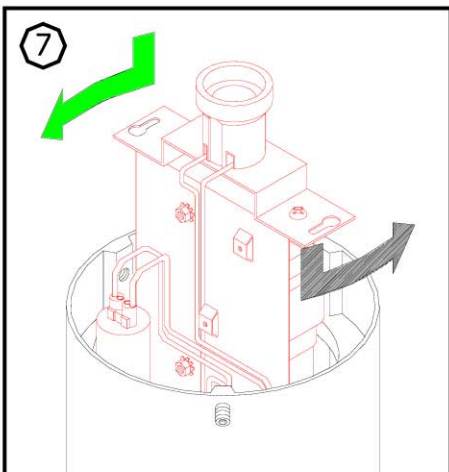
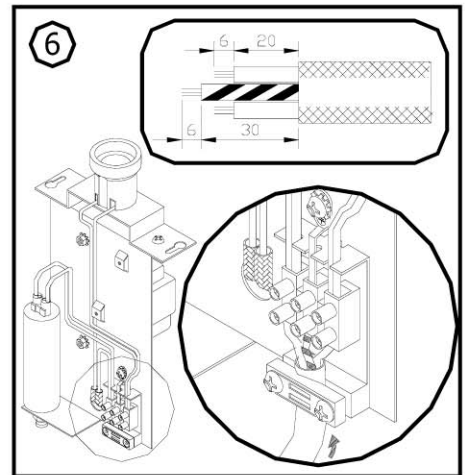
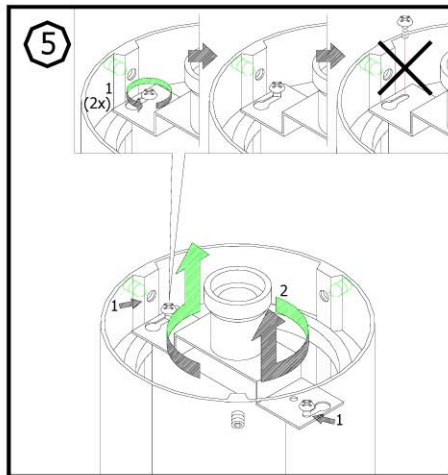
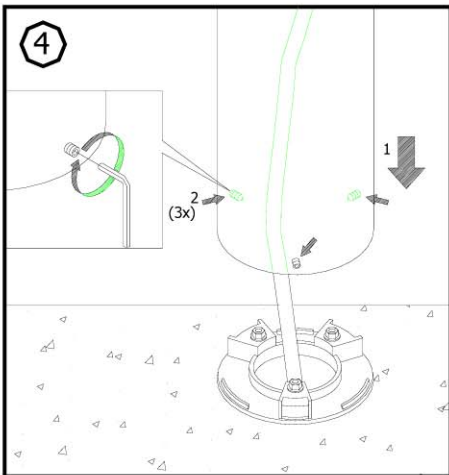
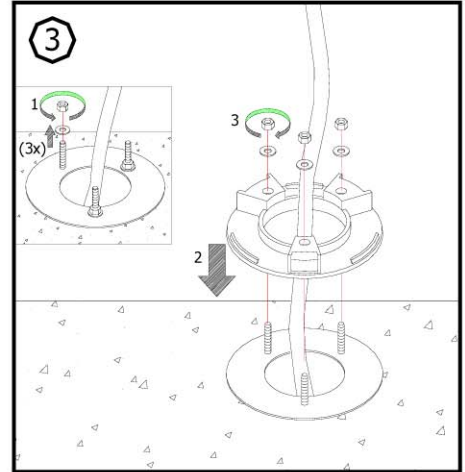
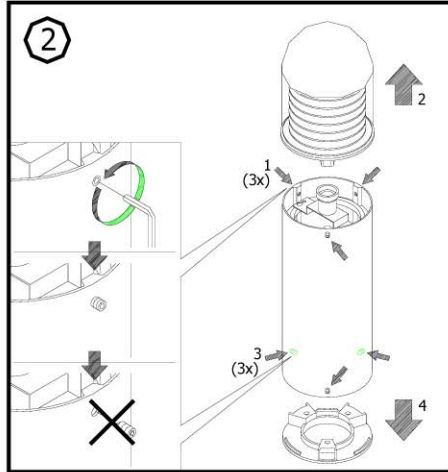
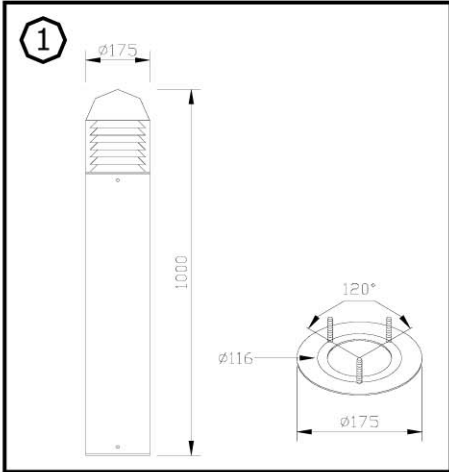

Applicable lamp :

1	230V 50Hz MAX A60 100W	4	230V 50Hz MAX TC-DSE 23W
2	230V 50Hz MAX QT32 100W	5	230V 50Hz MAX HME 80W
3	230V 50Hz MAX TC-D 26W	6	230V 50Hz MAX HSE-E 70W
		7	230V 50Hz MAX HIE-M 70W

REMARK :

- 1 INSTALLATION SHOULD BE CARRIED OUT BY A QUALIFIED ELECTRICIAN IN ACCORDANCE WITH APPROPRIATE NATIONAL WIRING REGULATION.
- 2 DISCONNECT THE POWER BEFORE CHANGING THE LAMP.
- 3 THIS IS CLASS 1 LIGHTING FIXTURE AND MUST BE EARTHED.
- 4 DO NOT EXCEED THE MAXIMUM WATTAGE.

ilmax