

# INSTRUCTION MANUAL FOR DL-4070

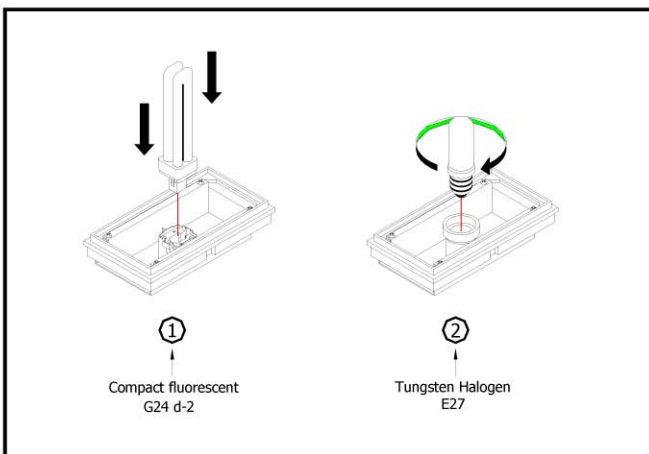
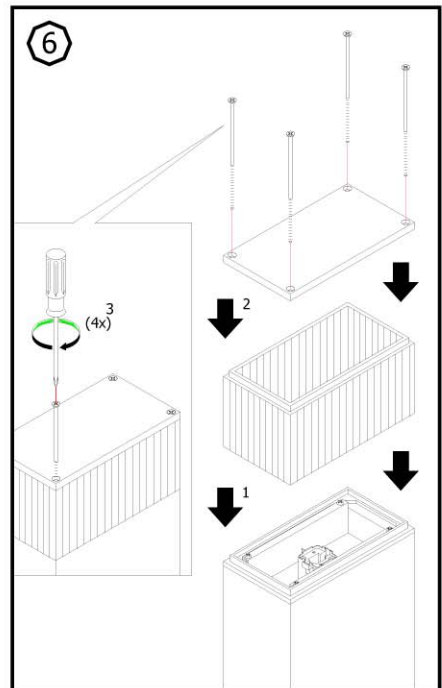
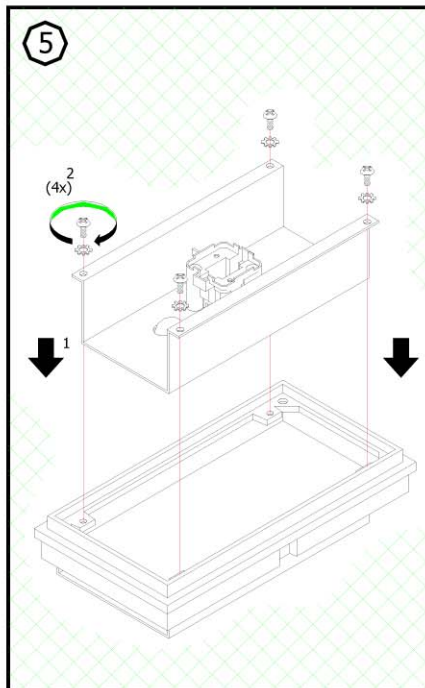
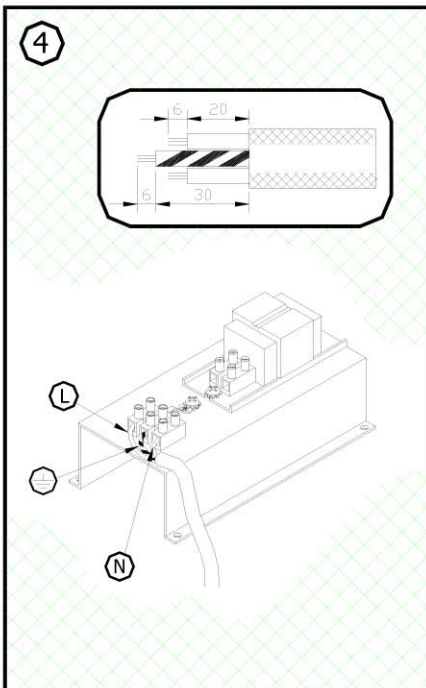
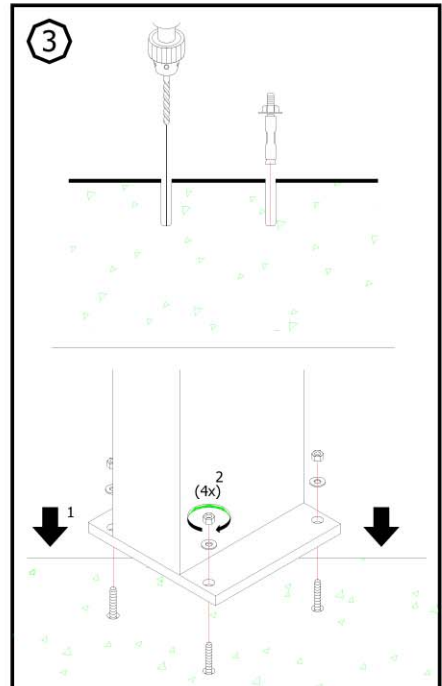
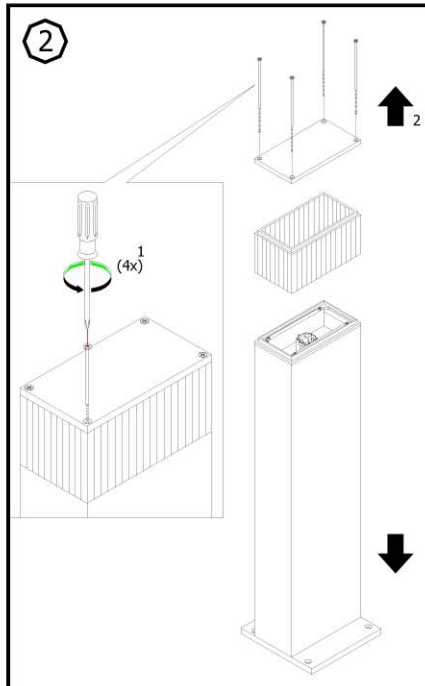
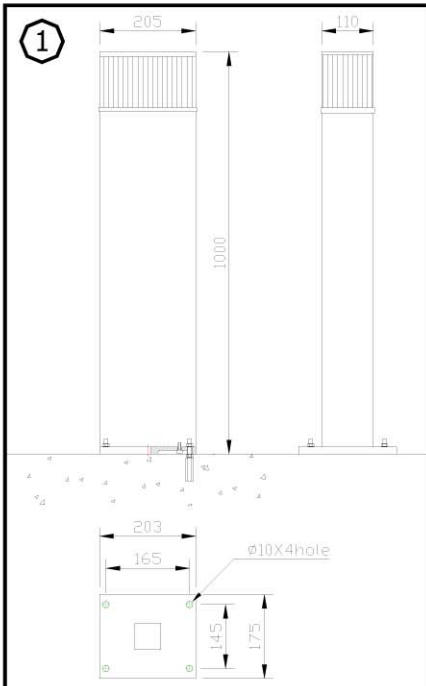

## Applicable lamp :

- |   |                        |
|---|------------------------|
| 1 | 230V 50Hz MAX TC-D 18W |
| 2 | 230V 50Hz MAX QT32 60W |

## REMARK :

- 1 INSTALLATION SHOULD BE CARRIED OUT BY A QUALIFIED ELECTRICIAN IN ACCORDANCE WITH APPROPRIATE NATIONAL WIRING REGULATION.
- 2 DISCONNECT THE POWER BEFORE CHANGING THE LAMP.
- 3 THIS IS CLASS 1 LIGHTING FIXTURE AND MUST BE EARTHED.
- 4 DO NOT EXCEED THE MAXIMUM WATTAGE.

