

EcoRich



Features

- Achieves a 50% or greater energy saving**
 (in the pressure retained mode, comparison with Daikin products)
 Drastic energy savings are realized by reducing the motor rotation speed in pressure retained operation.
 Our original highly efficient SR motor, controller and compact fixed-displacement pump are mounted.
- High-speed response**
 Combination of special SR motor, which has low rotation inertia and generates high torque at low rotation speed, and high-speed response inverter
 Response equivalent to or higher than conventional variable displacement pumps (Pressure retained operation ⇔ operation at maximum flow rate: 0.1 sec or less)

Nomenclature



1 Model No.

EHU: EcoRich EHU series

2 Pump maximum flow rate

14: 14 L/min
 25: 25 L/min
 30: 28.5 L/min

3 Output characteristic (Refer to the output characteristic diagram in the pressure – flow rate characteristics section.)

L:
 M:

4 Maximum operating pressure

04: 4.0 MPa
 07: 7.0 MPa (6.0 MPa with some models)

5 Control method

A: Pressure compensated control

6 Specifications of controller

No code: (In case of EHU14-L04, EHU25-L04)
 Without reactor
 E: (In case of EHU25-L07/M07, EHU30-M07)
 With reactor

7 Design No.

(May change according to model changes.)

8 Option symbol

No code: With fixed relief valve
 V: With variable relief valve

9 Non-standard No.

No code: Standard

Contact Details

Before using the product, please check the guide pages at the front of this catalog.

Internet

<http://www.daikinpmc.com/en/>

For latest information, PDF catalogs and operation manuals

Specifications

[Main specifications]

Model	Motor capacity (Nominal)	Tank capacity (L)	Maximum operating pressure (MPa)	Maximum flow rate (L/min)	Mass (kg)
EHU14-L04	Equivalent to 0.75 kW	10	4.0	14.0	43
EHU25-L04	Equivalent to 1.5 kW			25.0	
EHU25-L07	Equivalent to 2.2 kW				
EHU25-M07	Equivalent to 2.8 kW				
EHU30-M07	Equivalent to 2.8 kW		6.0	28.5	46

- Notes
- Maximum flow rate in continuous operation at maximum operating pressure:
 - EHU14: 5 L/min • EHU25: 5 L/min • EHU30: 5 L/min
 - The minimum setting for the PC (pressure compensator) pressure is 1.5 MPa. If the PC pressure is adjusted, it is necessary to reset the minimum rotational speed and to set the pressure at the safety valve to the PC pressure + 0.5 MPa. (With EHU40R, the safety valve is adjusted to 7.5 MPa, and therefore, no adjustment is necessary even when a low PC pressure is set. For details, refer to the Instruction Manual provided separately.)
 - If a bigger tank capacity and higher pressure are required, please use a Super Unit (SUT).

[Rated current]

Model	Rated current (A)			No-fuse breaker setting (A)
	200 V 50 Hz	200 V 60 Hz	220 V 60 Hz	
EHU14-L04	7.3	7.3	7.0	15
EHU25-L04	7.9	7.9	7.5	
EHU25-L07	5.7	5.7	5.3	
EHU25-M07	9.1	9.1	8.5	
EHU30-M07	9.6	9.6	8.7	

- Notes
- Use electric wires with a gauge equivalent to AWG14 (2.0 to 2.5 mm²) for power supply connections.
 - EcoRich is equipped with an inverter that incorporates the internal overcurrent protection function and therefore no thermal relay for overcurrent protection is required for EcoRich. If you use a thermal relay, it may malfunction due to the switching operation of the inverter.
 - Power supply voltage: 200 V (50 Hz), 200 V (60 Hz), 220 V (60 Hz), Permissible power-supply voltage fluctuation: ±10%

[Alarm/External input signal]

Model	Alarm signal	External input signal
EHU14-L04	COM-ALMa:	Motor run/stop
EHU25-L04	Normally closed, opened on occurrence of an error	
EHU25-L07	COM-ALMa:	
EHU25-M07	Normally open, closed on occurrence of an error	
EHU30-M07	Alarm contact switching capacity: DC 24 V, 0.5 A (minimum load current 10 mA) (at resistance load)	

- Notes
- The motor can be started or stopped by turning the external input signal (DIN0) on and off. (Use an external power supply with a capacity of DC 24±1 V, 0.5 A or greater.)
 - EHU40R-M07 has two terminals, DIN1 and DIN2, for external input signals, in addition to the signals indicated, to enable selection of the pressure and flow rate settings from among four internal preset patterns (PQ selection).
 - Use electric wires with a gauge equivalent to AWG22 (0.3 sq) for alarm and external input signal connections.

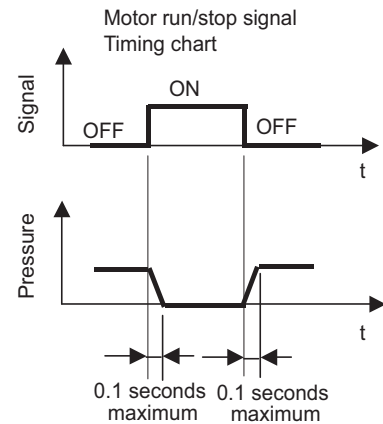

(Note: The response time varies depending on the volume of hydraulic oil and other factors.)

Contact Details

Before using the product, please check the guide pages at the front of this catalog.

Internet

<http://www.daikinpmc.com/en/>

For latest information, PDF catalogs and operation manuals

Pressure – Flow rate characteristics

Output characteristic (P-Q characteristic)

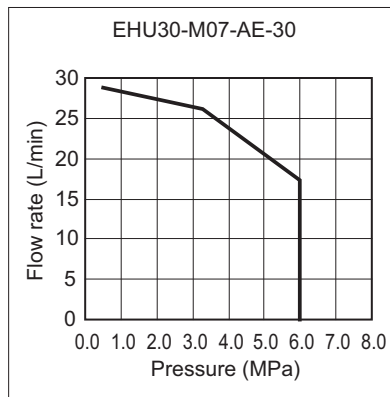
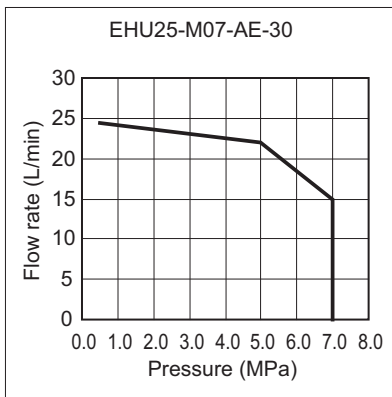
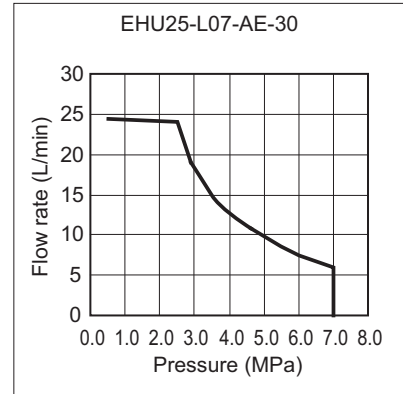
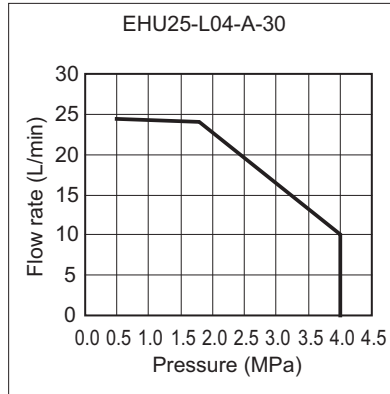
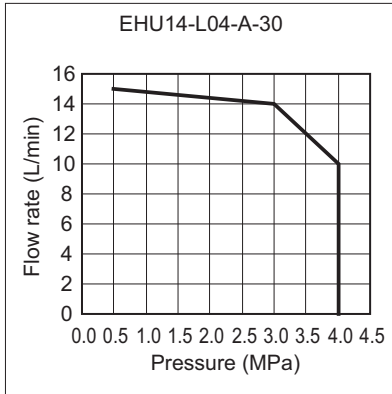

Detail of terminal box (EHU14, 25, 30)

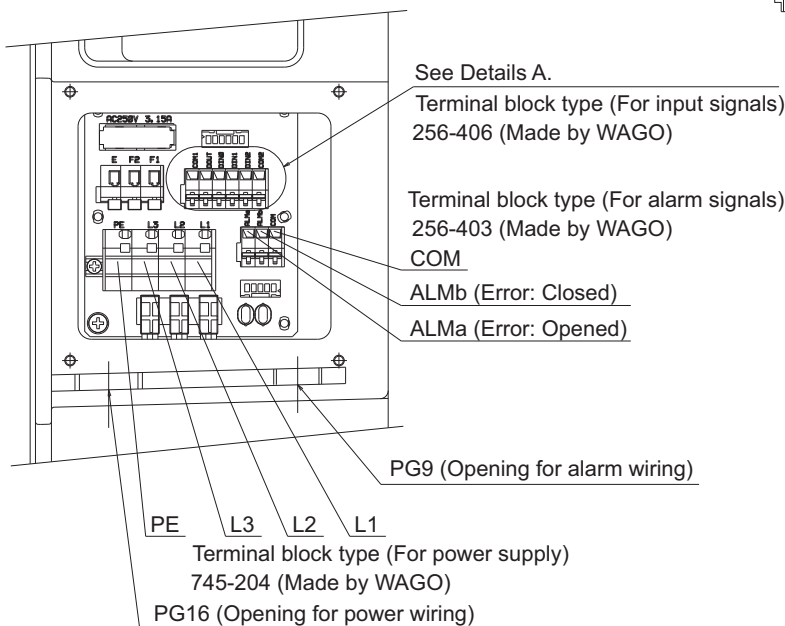

Wiring layout in the controller

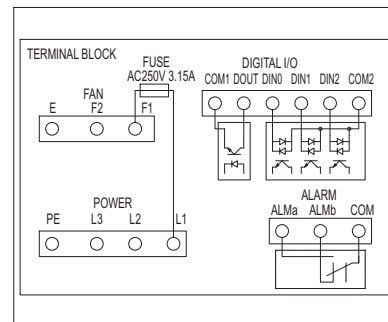
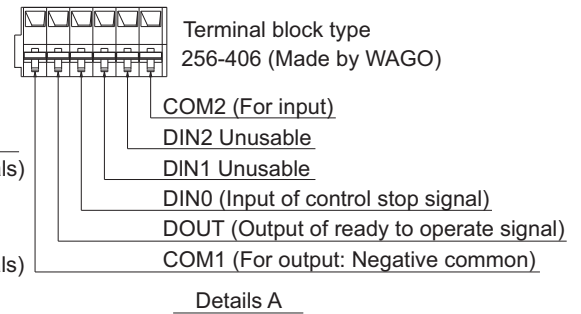

Wiring diagram

Contact Details

Before using the product, please check the guide pages at the front of this catalog.

Internet

<http://www.daikinpmc.com/en/>

For latest information, PDF catalogs and operation manuals

External dimension diagram

EHU14
EHU25
EHU30

Hydraulic circuit diagram

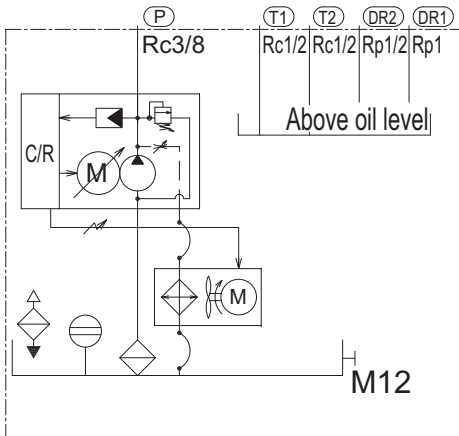

Dimension table

Model code	a	b
EHU14-L04	126	483
EHU25-L04	96.5	508
EHU25-L07	96.5	508
EHU25-M07	76.5	509
EHU30-M07	76.5	508

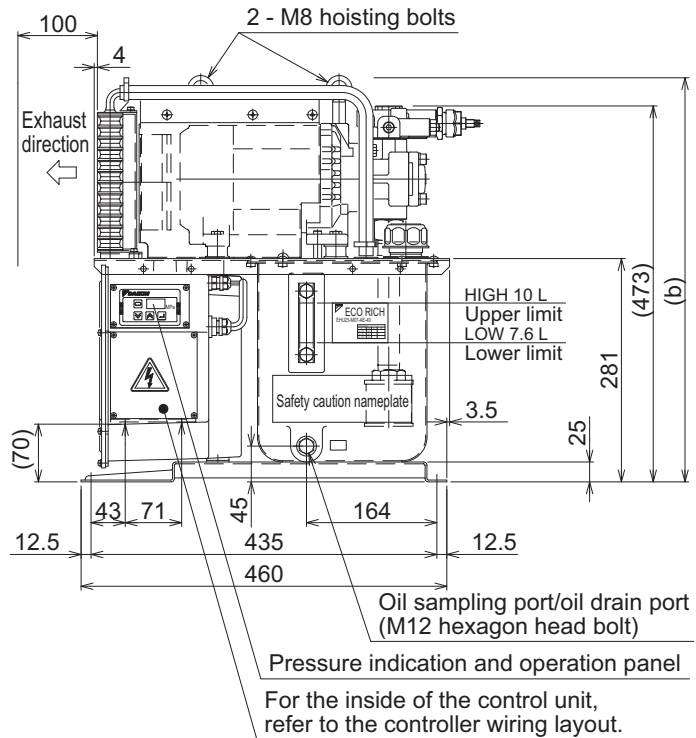
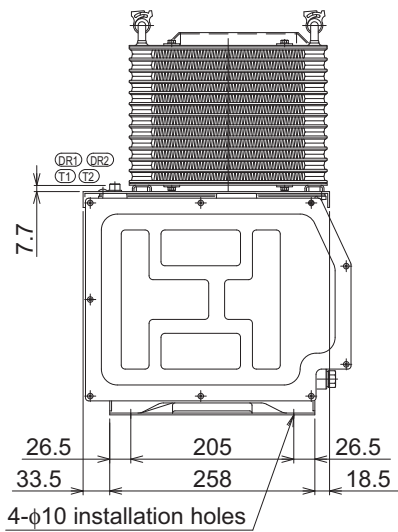
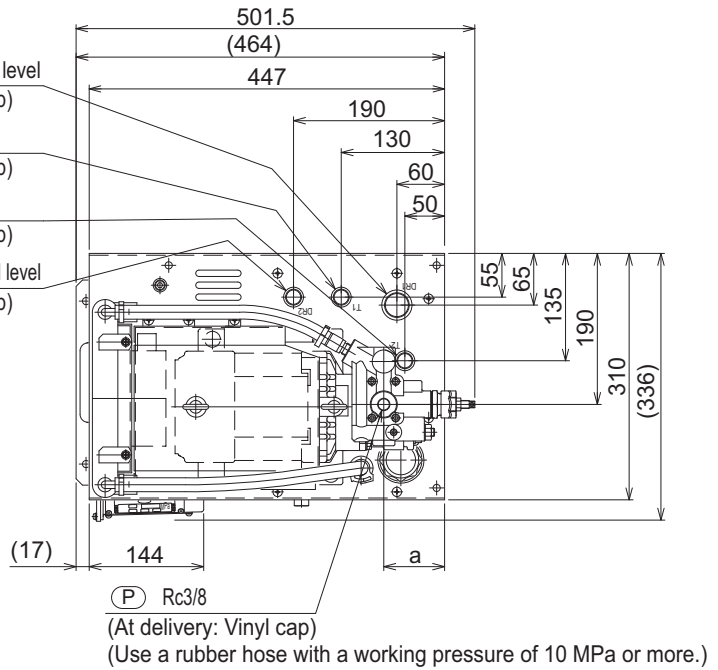

Optional parts (For EcoRich and EcoRich R)

Level switch

Model	Operation voltage	Maximum operation current	Contact resistance	Protection class	Alarm for oil temperature and action		CE standard	Applicable model
E-DLSN-130L-A-10	DC 24 V	0.05 A	1 Ω maximum	IP65	EHU14/25/30 (with 10 L tank) EHU15R/30R (with 20 L tank) EHU40R (with 30 L tank)	7.3 L or less 13 L or less 21 L or less	N/A	<ul style="list-style-type: none"> •Directly mountable on EHU14-L04 (0.75 kW) to EHU30-M07 (2.8 kW) at drain port DR2 (Rc1/2) •Mountable on EHU15R/30R (with 20 L tank) at drain port DR2 (Rc3/4) with a bushing (3/4 × 1/2) •Directly mountable on the EHU40R-M07 super unit at the option port (Rc1/2)
E-DLSN-130L-B-10								
E-DLSN-90L-A-10	DC 24 V	0.05 A	1 Ω maximum	IP65	EHU15R/30R (with 10 L tank)	7.2 L or less	N/A	<ul style="list-style-type: none"> •Mountable on EHU15R/30R (with 10 L tank) at drain port DR2 (Rc3/4) with a bushing (3/4 × 1/2)
E-DLSN-90L-B-10								

Temperature switch

Model	Operation voltage	Maximum operation current	Contact resistance	Protection class	Alarm for oil temperature and action		CE standard	Applicable model
E-MQT83PD-L60X1-10	100 VAC 24 VDC	2 AAC 50 mADC	30 mΩ maximum	IP65	Temperature rise over 60°C Temperature differential from 7 to 13°C	Open	N/A	<ul style="list-style-type: none"> •Mountable on EHU14-L04 (0.75 kW) to EHU30-M07 (2.8 kW) at drain port DR1 (Rc1) with a bushing (1 × 3/8) or DR2 (Rc1/2) with a bushing (1/2 × 3/8) •Mountable on EHU15R/30R at drain port DR2 (Rc3/4) with a bushing (3/4 × 3/8) •Directly mountable on the EHU40R-M07 super unit at the option port (Rc3/8)
E-MQT83PD-L60X1-1-10								

Handling

● Ambient conditions

1. Ambient temperature: 0 to 35°C, Ambient humidity: 20 to 85% RH, Altitude: 1,000 m maximum, To be used indoors

● Hydraulic oil

1. Mineral-oil base hydraulic oil should be used.
Use of other hydraulic oils (e.g. hydrous/synthetic) is prohibited.
2. Use hydraulic oil equivalent to ISO VG32 to 68 and operate the unit within an oil viscosity range from 15 to 400 mm²/s and a tank oil temperature from 0 to 60°C.
3. Oil cleanliness should be within NAS class 10.

● Installation and piping

1. To transport EcoRich, use eyebolts at the top of the unit.
Attach the bolt and spacer for protecting the rubber vibration isolator. If transportation is undertaken without the bolt and spacer, the rubber vibration isolator may be damaged and the EcoRich may fall. Take care not to subject the unit to strong impact due to dropping or a collision during transportation.
2. The unit is a stationary type. Fix it with bolts on a level location that is free of vibration.
3. Do not place any obstacles to oil cooler air intake and exhaust within a distance of 100 mm from intake and exhaust vent of the motor and the oil cooler. Install the unit at a location with good air flow so that heated air can be vented.
4. Use hoses for piping to provide flexibility.
5. Before operating the unit, be sure to remove the bolt and spacer for protecting the rubber vibration isolator. If you fail to do so, the noise and vibration may be excessive.

● Electric wiring

1. When the wire is connected from the power source, the required protectors should be installed and the wiring must conform to the applicable laws, regulations, and standards. (For example, the unit should be equipped with an electric circuit conforming to European Standard EN60204-1 to protect electrical circuits from over current, in the event of short circuits for example, and to protect the control unit from overloading.)
The unit should be equipped with an earth leakage breaker to prevent electric shock and other hazards.
2. Securely connect wires with appropriate gauges in accordance with the wiring diagram on the back of the terminal cover. Be sure to provide a ground connection with a grounding resistance of 100 Ω maximum.
3. Use a commercial power supply for the power source. The use of an inverter power supply may cause burn damage to the unit.

● Other precautions

1. If a failure occurs in the hydraulic unit, the system indicates an alarm and terminates.
2. If a failure or malfunction of this unit is expected to cause death or pose a danger to human beings, adopt appropriate safety measures in the facilities. If this unit is applied in an important facility, also adopt appropriate safety measures in the facility to ensure that a failure of the equipment will not lead to a serious accident or loss.
3. It takes 5 to 13 seconds for this hydraulic unit to start up after being switched on. During this time, the alarm signal circuit is open. This is not abnormal.
4. Do not turn the main power supply ON/OFF frequently to stop the unit. It may damage inverter components.