

Super Unit

[Single pump type]

Maximum operating pressure

10 MPa

Maximum flow rate

30 L/min

Model code

SUT××S3010-30

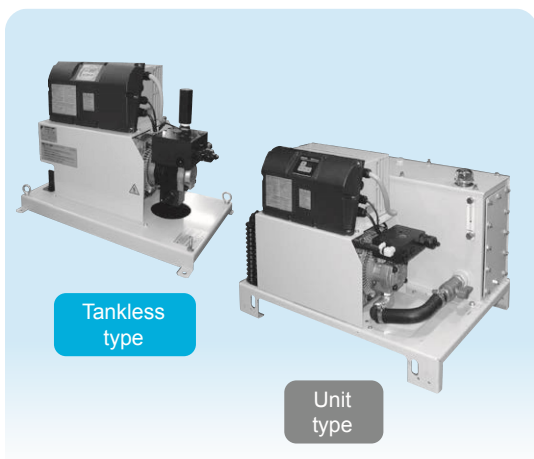

Pressure – Flow rate characteristics (Representative)

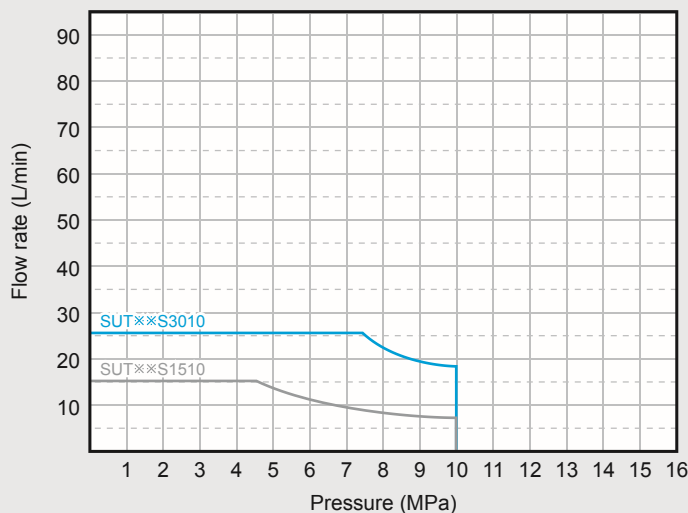

* The graph shows actual flow rates (representative values).

* Operating flow rate at the maximum pressure in continuous operation:
5 L/min maximum

Specifications

| Model code | | Tankless type | Unit type |
|----------------------------------|---|--|---------------|
| Model code | | SUT00S3010-30 | SUT03S3010-30 |
| Pump unit | Maximum flow rate (theoretical value; L/min) *1 | 25.6 | |
| | Maximum operating pressure (MPa) | 10.0 | |
| | Operating flow rate adjustment range (L/min) | 3.4 to 25.6 | |
| | Operating pressure adjustment range (MPa) | 1.5 to 10.0 | |
| Motor capacity | Motor capacity (equivalent kW) | Equivalent to 3.7 kW | |
| Power supply | Motor pump/unit | 3-phase, 200 V (50 Hz), 200 V (60 Hz), 220 V (60 Hz) (Permissible voltage fluctuation: ±10%) | |
| Rated current (A) | AC3 φ200V (50 Hz) | 18.4 | |
| | AC3 φ200V (60 Hz) | 18.4 | |
| | AC3 φ220V (60 Hz) | 16.9 | |
| Power source breaker setting (A) | | 20 | |
| External input signal | | 5 channels Photo-coupler insulation, DC 24 V (DC 27 V maximum), 5 mA/channel | |
| External output signal | Digital output | 2 channels, photo coupler insulation, FET output, DC 24 V, 50 mA maximum per channel | |
| | Contact output | 1 channel (1 common contact), dry contact Contact capacity: DC 30 V, 0.5 A (resistance load) | |
| Mass (kg) | | 46 | 64 |
| Operating conditions | Usable oil *2 | Special mineral-oil base hydraulic oil/wear-resistant hydraulic oil • Viscosity grade: ISO VG32 to 68 • Viscosity range: 15 to 400 mm ² /s • Contamination: Within NAS class 9 • Volumetric water content: 0.1% maximum | |
| | Operating hydraulic oil temperature (in tank) | 0 to 60°C (Recommended operating temperature range: 15 to 50°C) | |
| | Operating ambient temperature | 0 to 40°C | |
| | Storage ambient temperature | -20 to 60°C | |
| | Operating ambient humidity | 85% RH max. (no condensation) | |
| | Installation site | Indoors (Be sure to secure the unit with bolts.) | |
| Others | | <ul style="list-style-type: none"> • Be sure to connect a circuit breaker for all (three) poles and the earth leakage breaker. • Make sure that the electrical wiring meets the requirements of European Standard EN60204-1. • Frequent turning this unit's power supply ON/OFF will considerably shorten the control unit's service life. To start or stop the unit at 8-minute or shorter intervals, use the unit's control stop function. • Be sure to connect the ground terminal. | |
| Tank capacity (L) | | - | 30 |
| Standard coating color | | Ivory white (Munsell code 5Y7.5/1) | |

Note) *1: The pump flow rate has been factory-set to the maximum discharge rate. The maximum discharge rate given in the table above is a theoretical value, not a guaranteed value.

*2: Consult Daikin about the use of hydraulic oils other than mineral-oil base type (e.g. hydrous/synthetic) such as water-glycol hydraulic oil. Keep the contamination level of the hydraulic fluid within NAS contamination class 10 for operating pressures of 7 MPa or lower.

*3: The unit incorporates a safety valve.

*4: When selecting a Super Unit, refer to "Pressure-Flow rate characteristics and how to select a unit" on Page 49.

For the purpose of making improvements, the specifications given in catalogs are subject to change without prior notice. Be sure to refer to the latest outside drawing.

External Dimension Diagram

Tankless type

SUT00S3010-30

| Part No. | Name | Quantity |
|----------|---------------------------------------|----------|
| 1-1 | Motor pump incorporating an IPM motor | 1 |
| 1-2 | Controller | 1 |
| 2 | AC fan | 1 |
| 3 | Base | 1 |

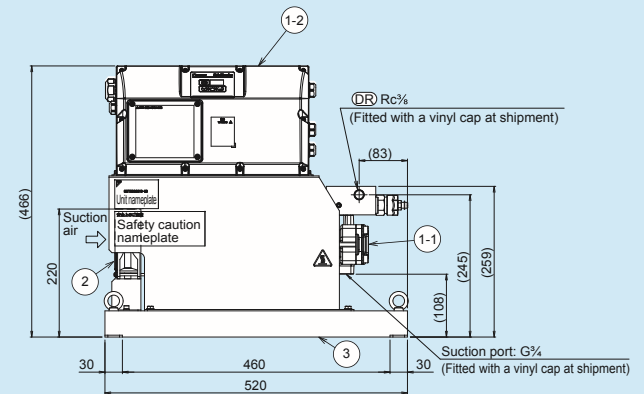
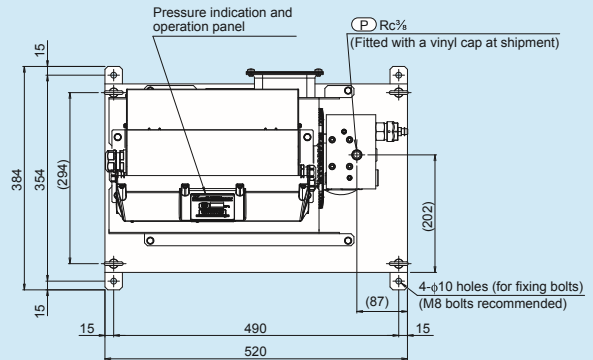
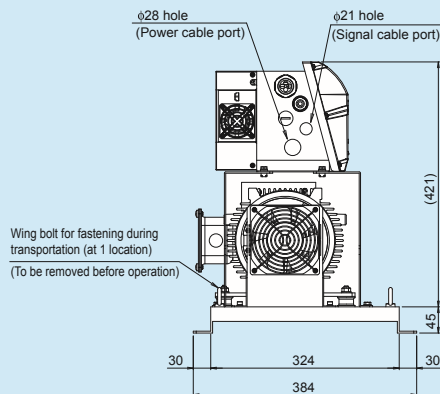

Unit type

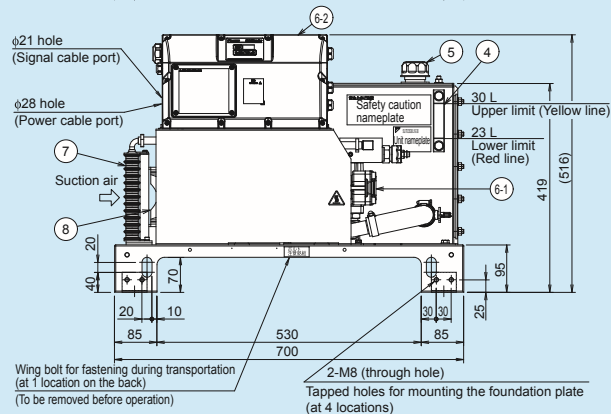
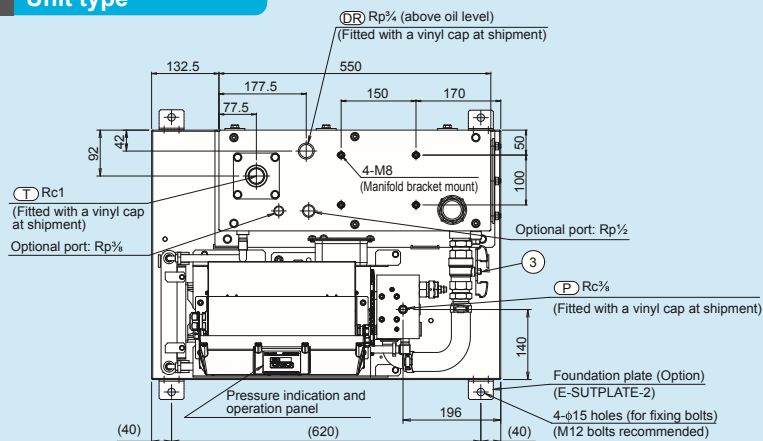

SUT03S3010-30

| Part No. | Name | Quantity |
|----------|---------------------------------------|----------|
| 1 | Oil tank | 1 |
| 2 | Suction strainer | 1 |
| 3 | Stop valve | 1 |
| 4 | Oil level gauge | 1 |
| 5 | Oil filler port-cum-air breather | 1 |
| 6-1 | Motor pump incorporating an IPM motor | 1 |
| 6-2 | Controller | 1 |
| 7 | Oil cooler | 1 |
| 8 | AC fan | 1 |

