



SAFARI R-SPEC SNORKEL

SS136R

01/04/15

ITEM	DESCRIPTION	QTY	PART No.
1	BODY-SNORKEL	1	315-133-500R
2	3 1/2" AIR RAM ASSEMBLY	1	000-135-800
3	BRACKET-UPPER MOUNTING	1	315-032-500
4	BOLT-HEX 6mm x 1.0mm x 14mm	3	000-002-100
5	SCREW - S/T 4.2mm x 13mm	3	000-951
6	BODY CLIP - PLASTIC	3	000-960
7	HOSE-AIR ENTRY	1	315-024-600
8	STUD - S/S 8mm x 1.25mm x 25mm O/L	5	000-110
9	WASHER-BODY 8mm x 30mm	5	000-311-300
10	NUT-NYLOC 8mm x 1.25mm	5	000-205-300
11	CLAMP-HOSE 70/90mm	2	000-908
12	TEMPLATE	1	315-017-500
13	HOSE CLAMP-SIZE 56 (BLACK)	1	000-914/B
14	ADAPTOR - AIR CLEANER ENTRY	1	315-023-500
15	POP RIVET - 4mm x 12mm	3	000-958

WARNING!!

**IT IS AN INSTALLER
RESPONSIBILITY TO VERIFY
ALL COMPONENTS, AND
PARTICULARLY THE
TEMPLATE ARE CORRECT,
BEFORE STARTING ANY PART
OF THE SNORKEL
INSTALLATION.**

**(CHECK TEMPLATE AGAINST
SNORKEL BODY)**



SAFARI R-SPEC SNORKEL

SS136R

TOYOTA HILUX & SR5 HILUX 3.4L V6 PETROL (5VZ-FE ENGINE)

Fitment to: Right hand side
Fitting time: Approximately 120 minutes
Special Tools: 92mm holesaw
Air Hacksaw
Step Drill
Pop Rivet Gun
Silicone Sealant (sensor safe)

Instructions:

1. Remove: Right hand front wheelarch liner
Air cleaner assembly
Standard air cleaner ducting
2. Tape the template to the upper rear corner of the right hand guard, using a felt tip pen mark all hole positions including the cut away section. Remove the template.

3. Drill a pilot hole for each hole position. Using the step drill, drill the 5 snorkel mounting hole positions to 16mm, using the 92mm holesaw, drill the main hole, using the air hacksaw, enlarge the main hole as per the cut away section of the template, de-burr and paint all holes.
4. Screw the 5 mounting studs into the snorkel body inserts, carefully position the snorkel body onto the guard and secure with 2 or 3 nuts and washers. With the snorkel body correctly positioned on the guard, fasten the upper mounting bracket to the snorkel body, mark the 3 mounting hole positions on the "A" pillar (the bracket should run parallel with the windscreen rubber), holding the snorkel in position on the "A" pillar carefully open the front door and check the snorkel body and mounting bracket has adequate clearance to the door frame.
5. Remove the snorkel body and drill the 3 marked hole positions on the "A" pillar to 8mm. De-burr and paint all holes. Insert plastic body clips into "A" pillar.
6. Remove the standard air cleaner entry snout from the air cleaner housing, position the air cleaner adaptor (Item No. 14) onto the air cleaner housing. With the adaptor in position mark 3 positions on the adaptor at approximately 11 o'clock, 3 o'clock and 7 o'clock on the adaptor (make sure operation of the drill and the pop rivet gun is achievable in all 3 positions). Remove the adaptor and drill the 3 marked positions to 4.5mm, re-position the adaptor onto the air cleaner housing and drill the 3 hole positions on the air cleaner housing, remove the adaptor and clean both surfaces. Apply a liberal amount of silicone sealant to the air cleaner housing and the adaptor, position the adaptor onto the air cleaner housing and secure to the air cleaner housing using pop rivets supplied, clean up any excess silicone sealant.
7. Re-install the air cleaner assembly to vehicle, apply a small amount of lubricant to either end of the air entry hoses, connect air entry hose (Item No. 7) to air cleaner entry adaptor, fasten hose using hose clamp supplied. The remaining hose clamp will need to be shaped and placed into position at the other end of the hose.
8. Install snorkel body to guard, guiding the snorkel snout into the air entry hose with the snorkel body correctly positioned fasten using hardware supplied.
9. Fasten upper mounting bracket to the snorkel body and secure to "A" pillar install air ram assembly and fasten.
10. Fasten air entry hose to snorkel snout. Re-install wheel arch liner

N.B. It is the installers responsibility to ensure all connections are water tight

SAFARI

4X4 ENGINEERING

Model No: **SS136R**
 Description: TOYOTA HILUX 3.4L V6 PETROL (5VZ-FE ENGINE)
 Sub Assembly: SAFARI SNORKEL

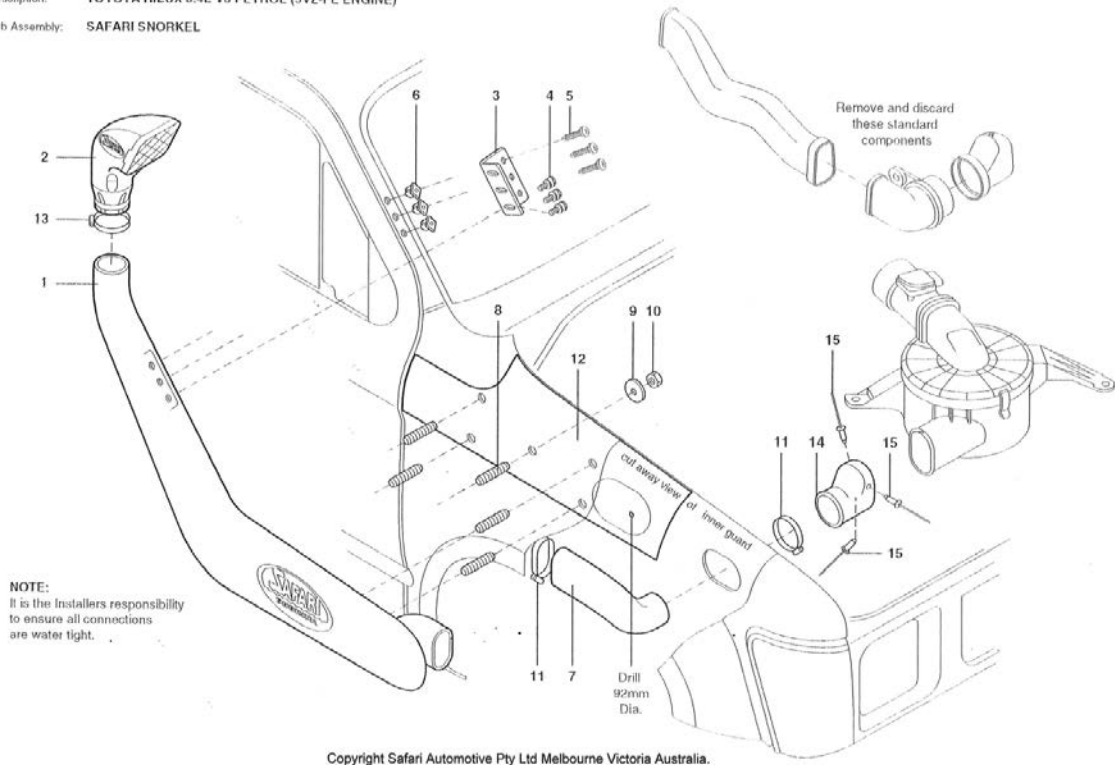

Copyright Safari Automotive Pty Ltd Melbourne Victoria Australia.