

Part No. 750017

MAZDA CX-3	(JMODKJ2H***W1)	03/15 >> 02/17
MAZDA CX-3	(MMODK4W7A***W2)	02/17 >>
MAZDA 2	(JMODKJ2H***W1)	03/15 >> 01/17
MAZDA 2	(MMODK4W7A***W2)	02/17

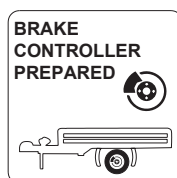

SCAN FOR
LATEST
INSTRUCTIONS

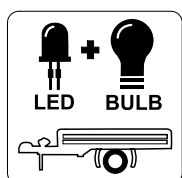
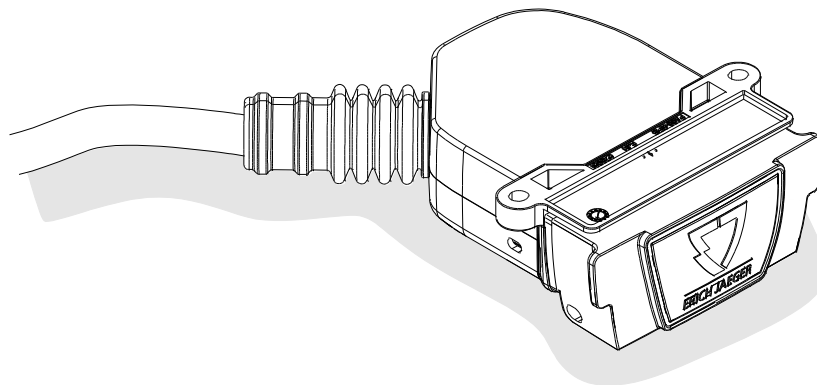

Reference:

The following information must be reviewed before beginning the assembly:

The installation instructions are to be thoroughly read.

The installation should be carried out by qualified personnel with the relevant technical knowledge. The vehicle manufacturers' current technical notices and information on retrofitting must be followed. The removal and replacement instructions found in the current repair manuals must be followed.

It must be ensured that the vehicle is technically suitable for the installation of a trailer hitch.

OVERVIEW

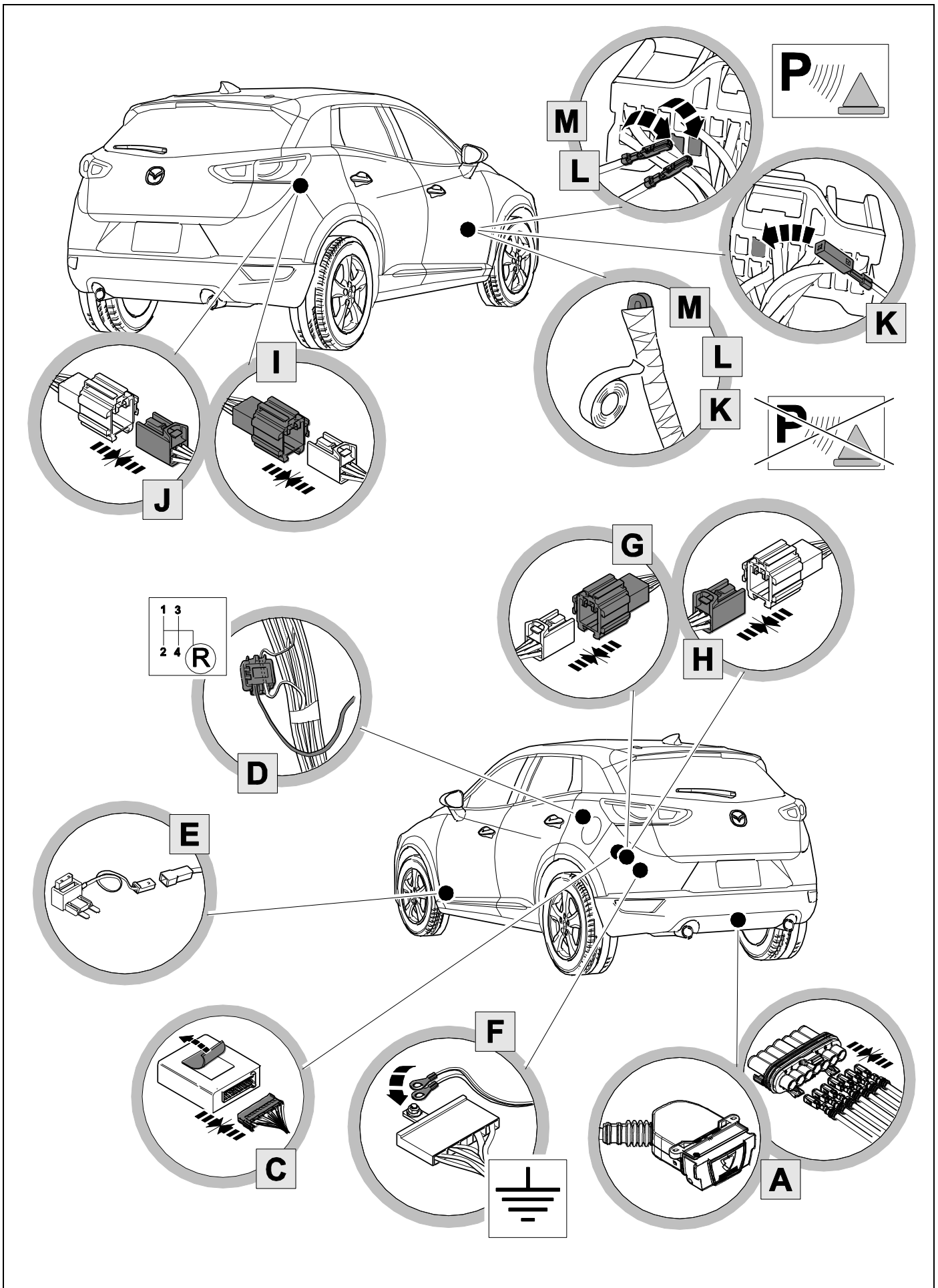

KIT

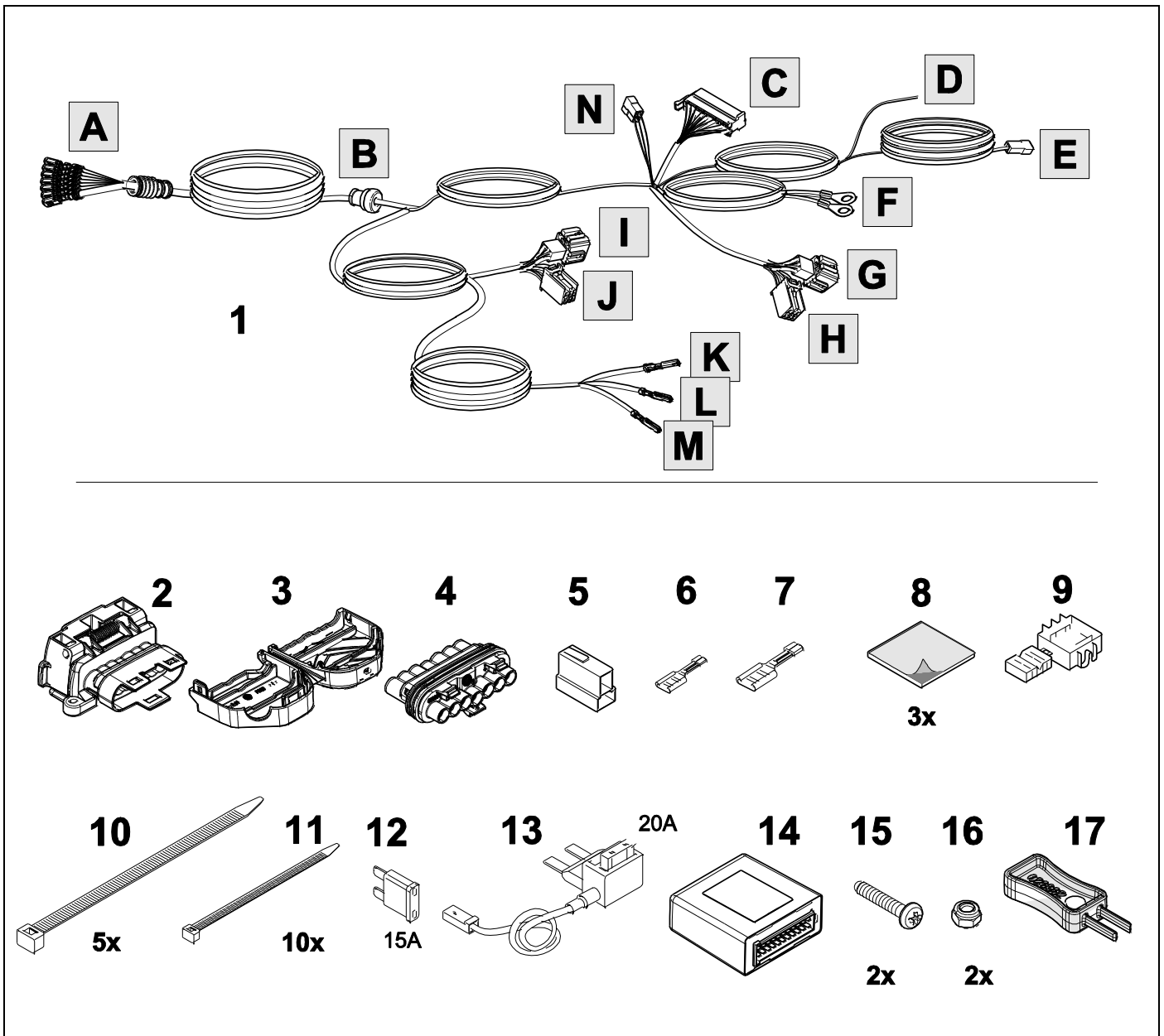

TOOLS

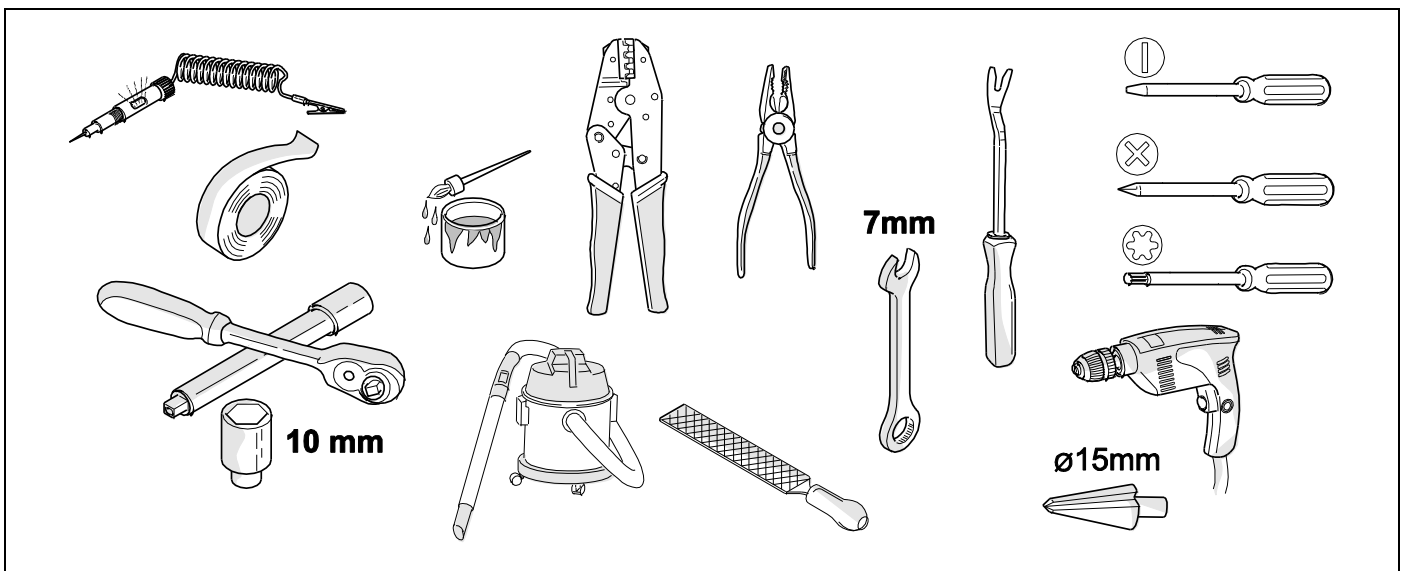

1

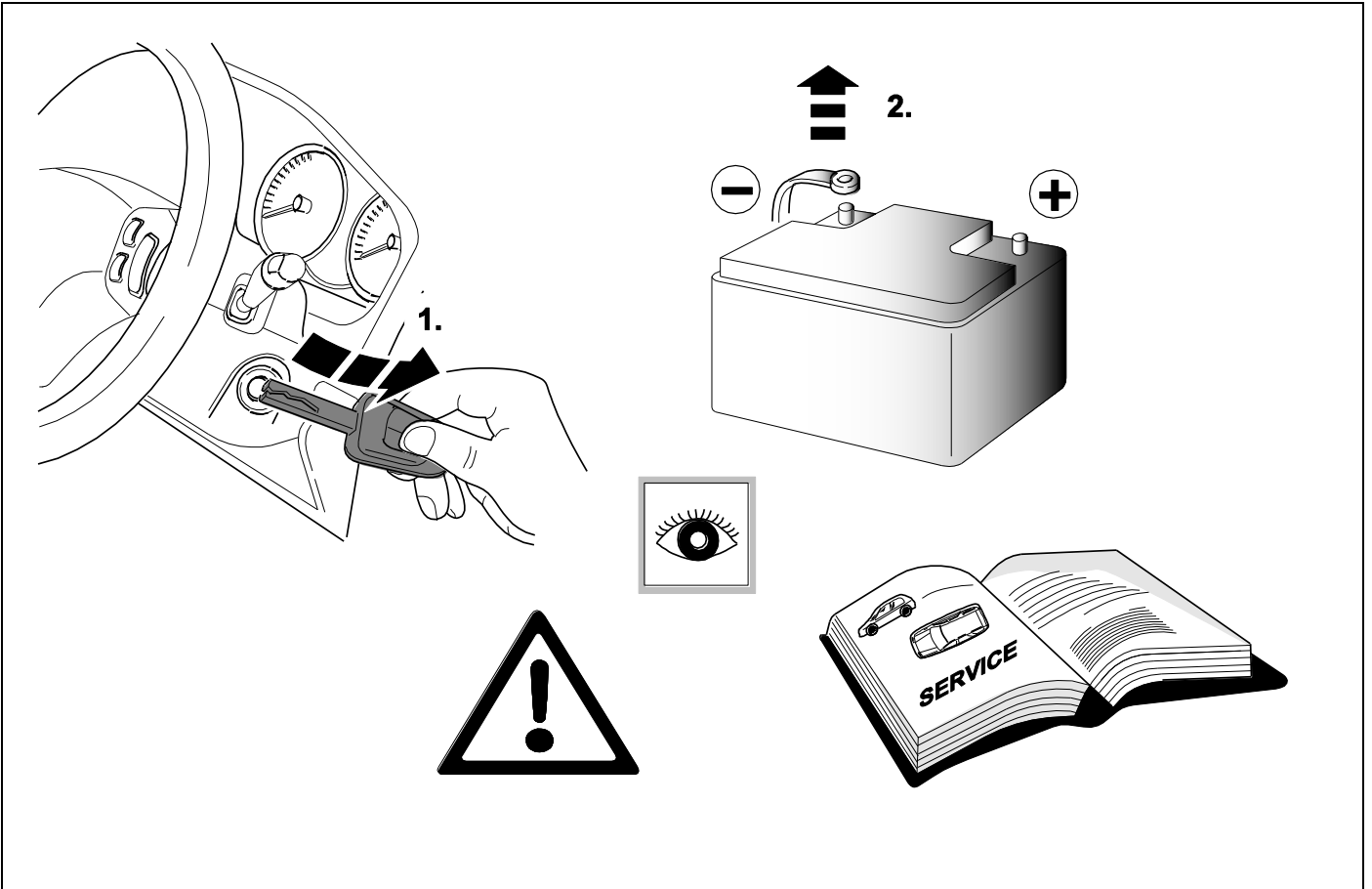

2 REMOVE

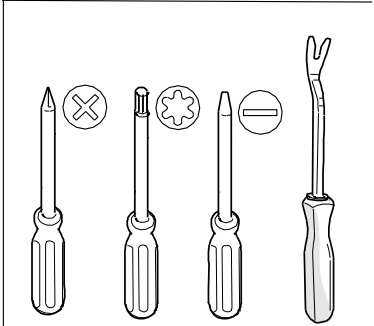
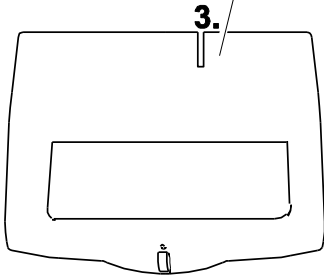
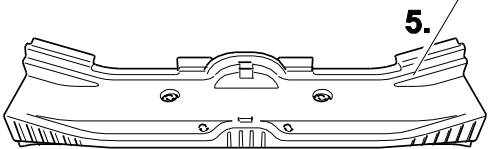
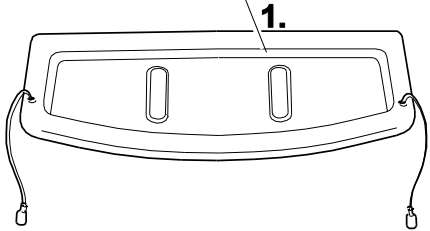
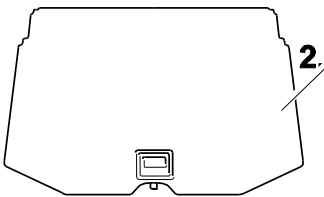
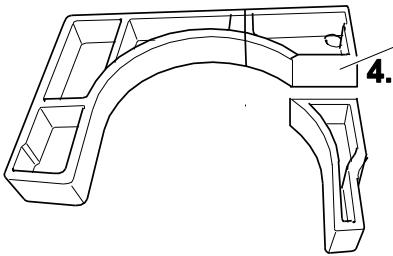
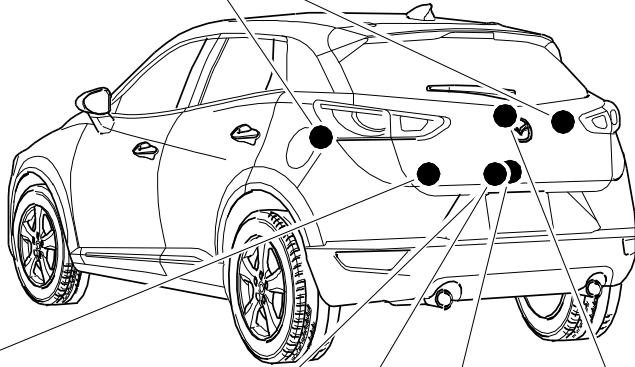
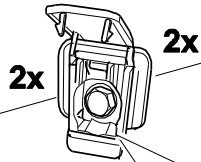
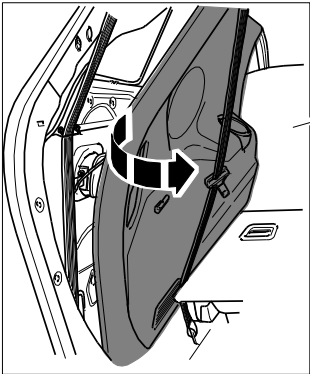
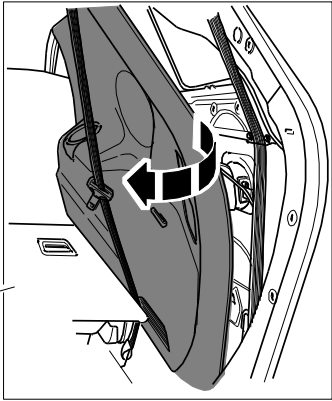
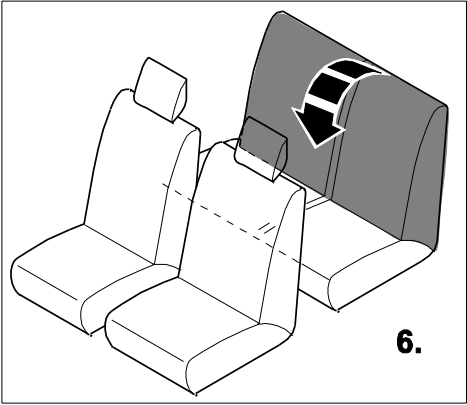

3

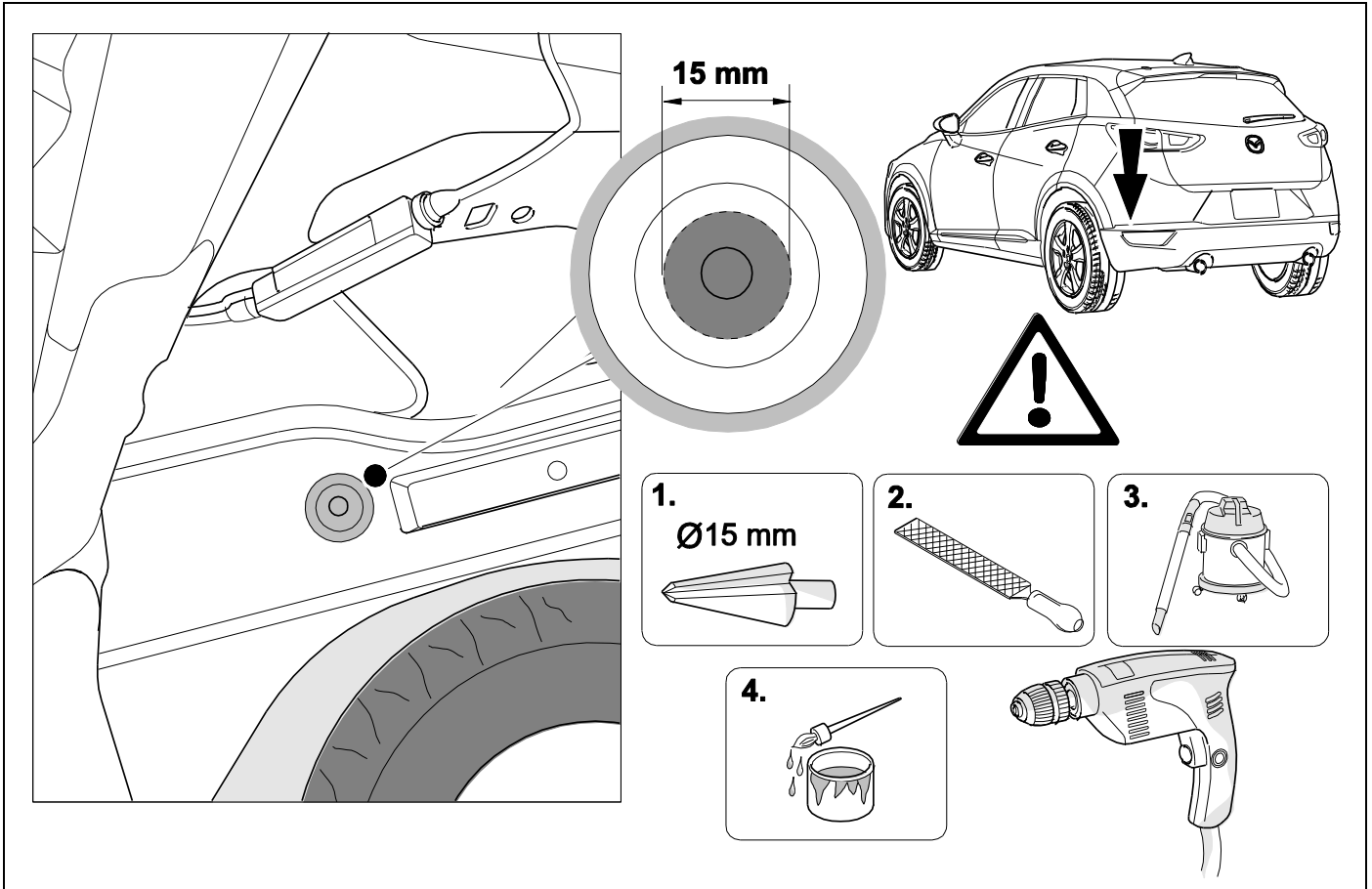

4

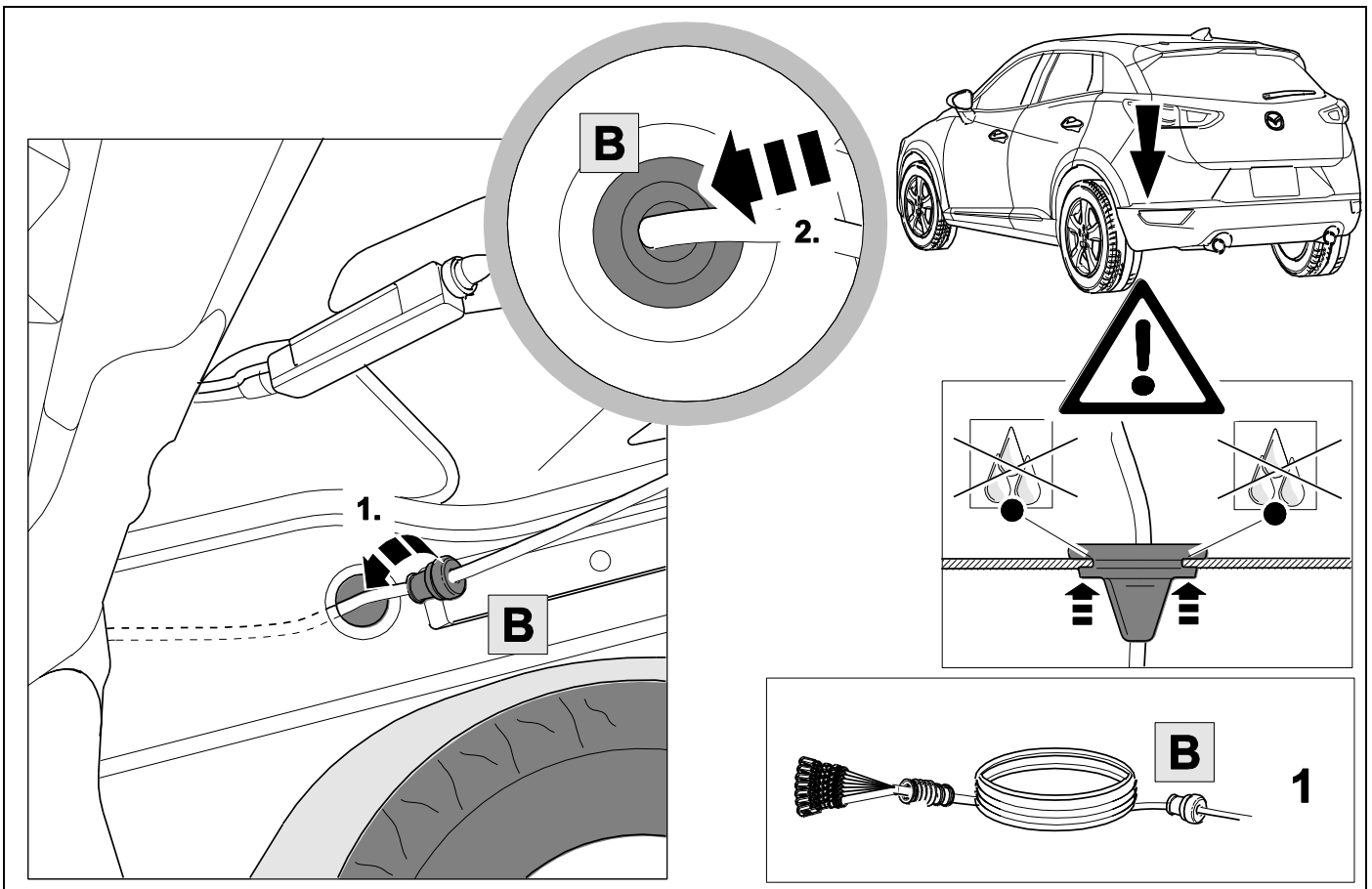

5

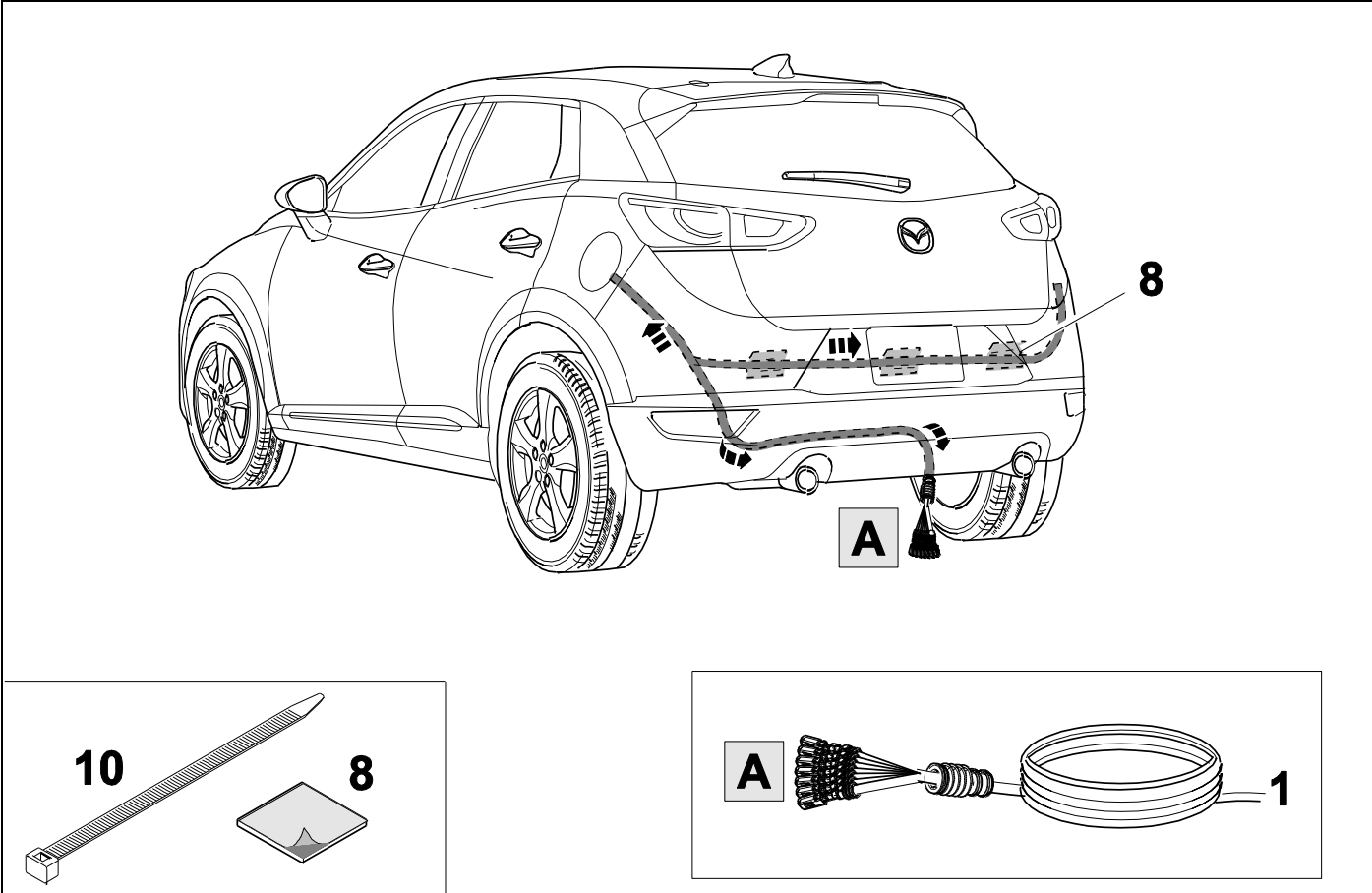

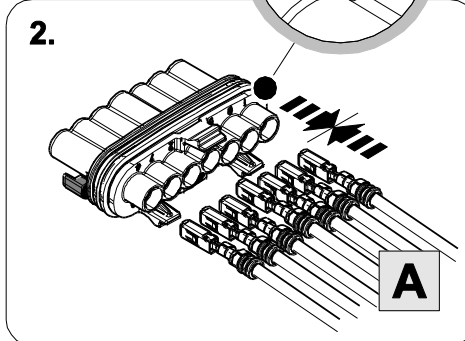
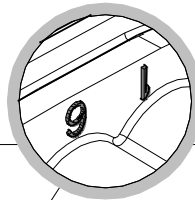
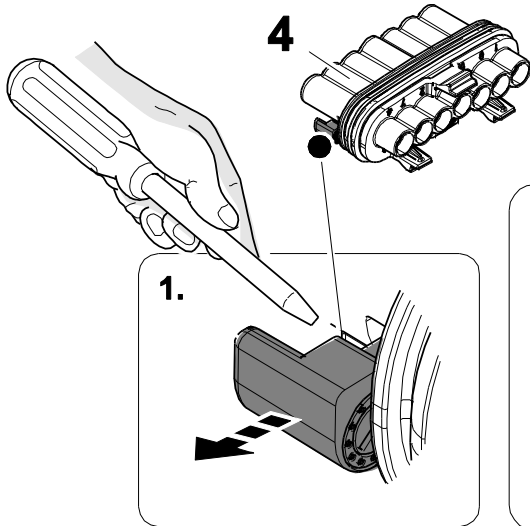

ye	1	
rd	6	
bu	5	
wh	3	
bk	2	
bn	7	
gn	4	

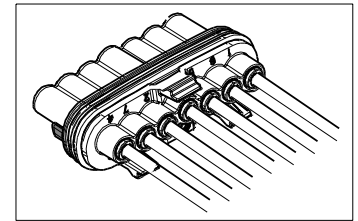
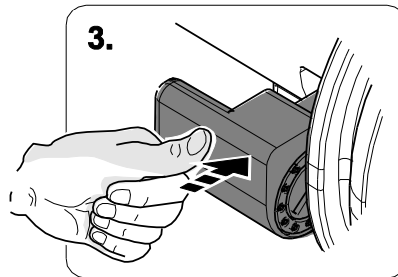
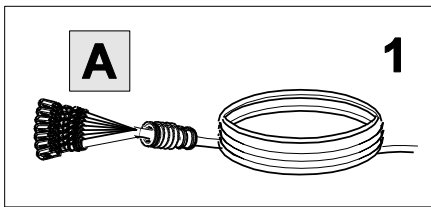

In case of wrong pin insert:

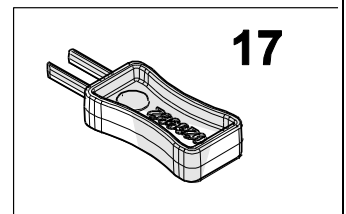
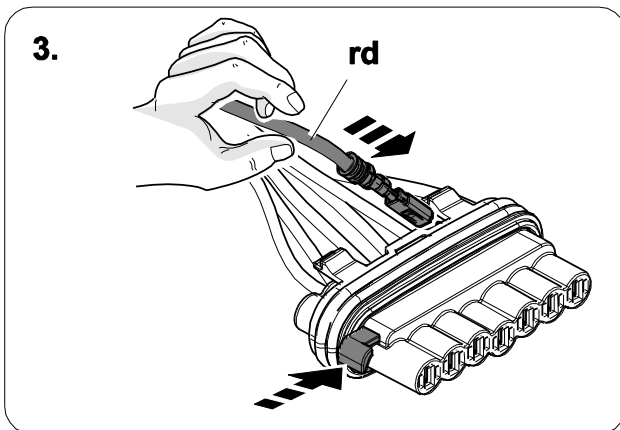
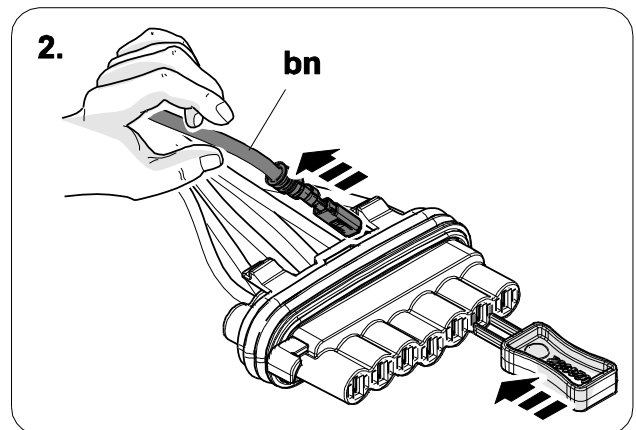
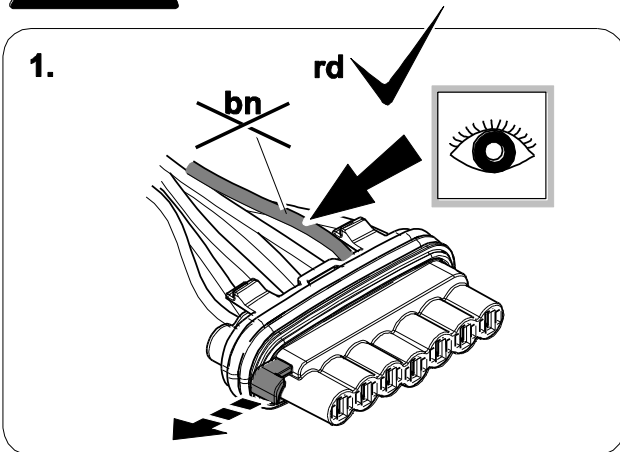

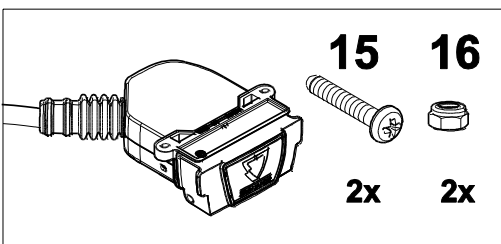
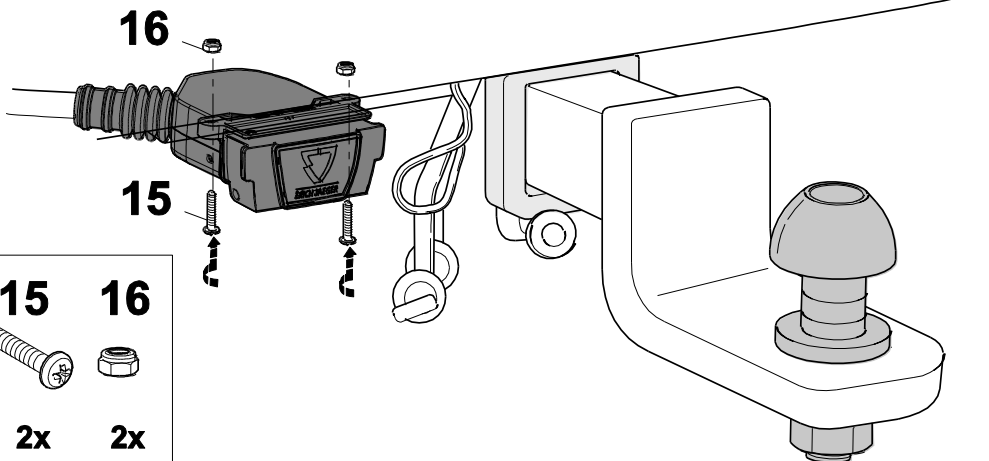
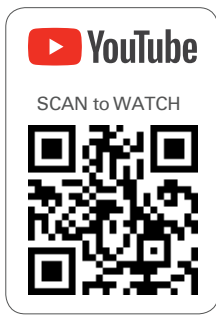
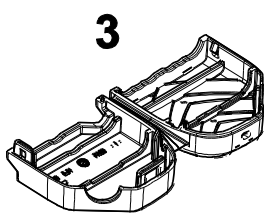
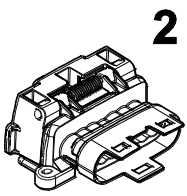
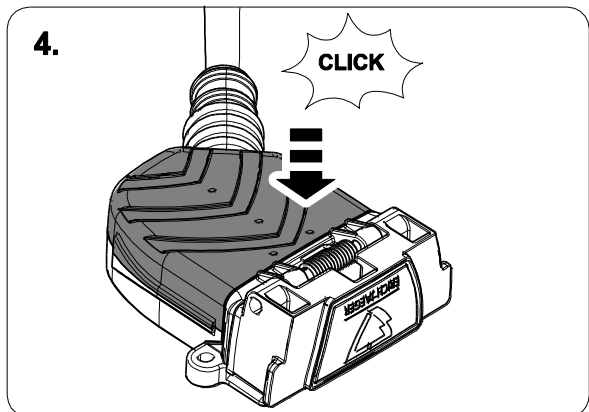
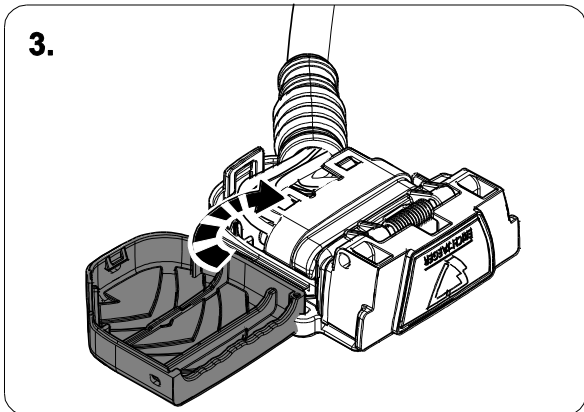
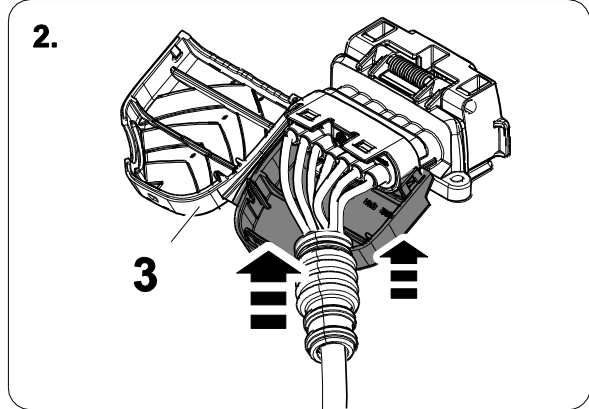
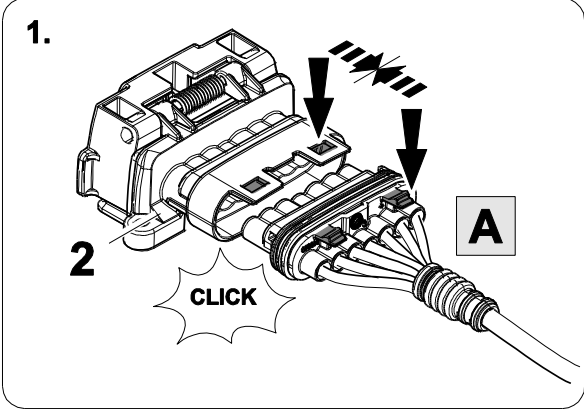

9

👁️ ⇒ 10

1	ye	←
2	bk	1 3 2 4 (R)
3	wh	⏏
4	gn	→
5	bu	🔌
6	rd	Stop 🛑
7	bn	☹️

10	bk	wh	gy	gn	rd	bu	ye	bn	pu	or	no
----	----	----	----	----	----	----	----	----	----	----	----

GB	black	white	grey	green	red	blue	yellow	brown	purple	orange	not occupied
----	-------	-------	------	-------	-----	------	--------	-------	--------	--------	--------------

11

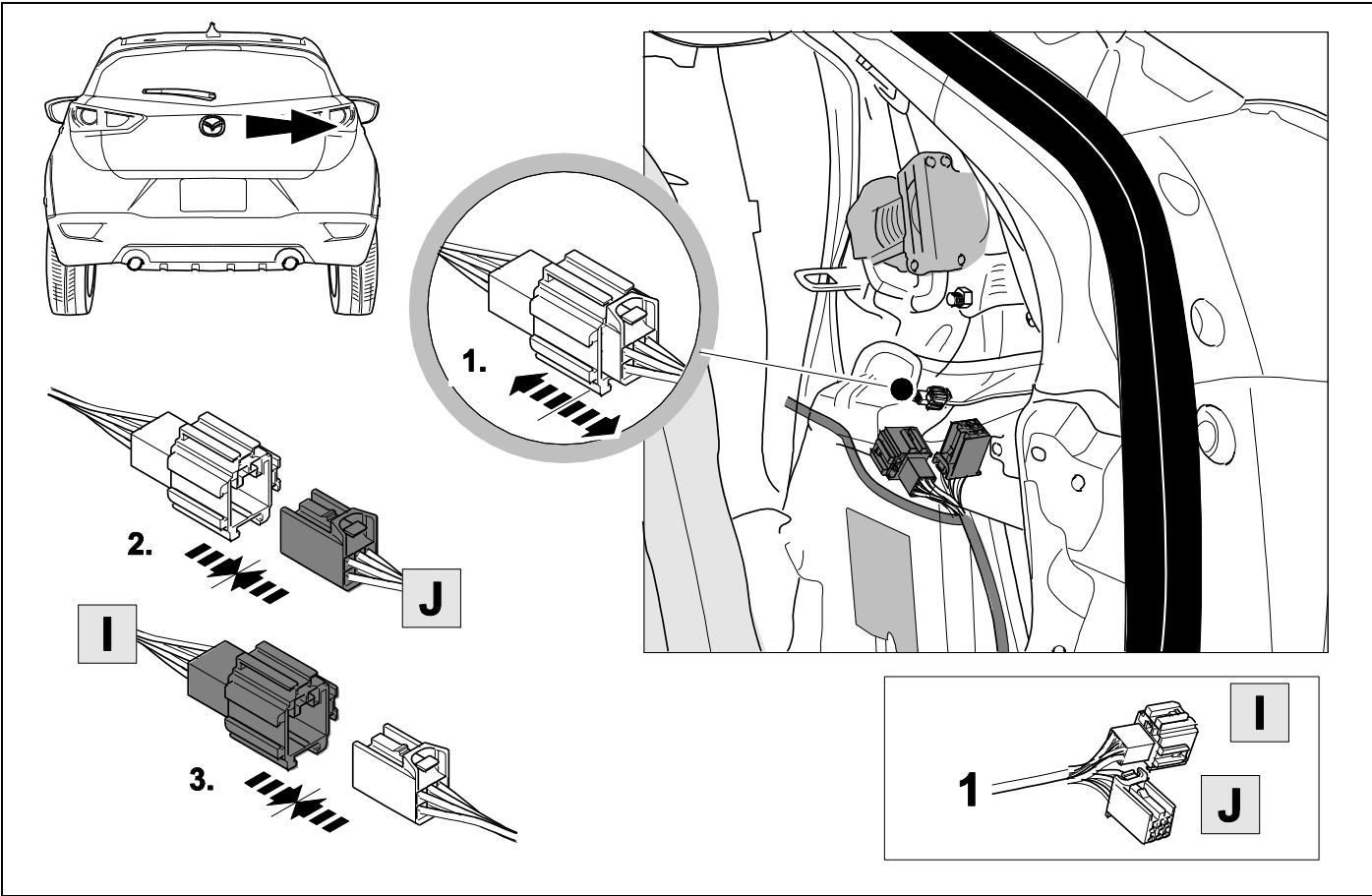

12

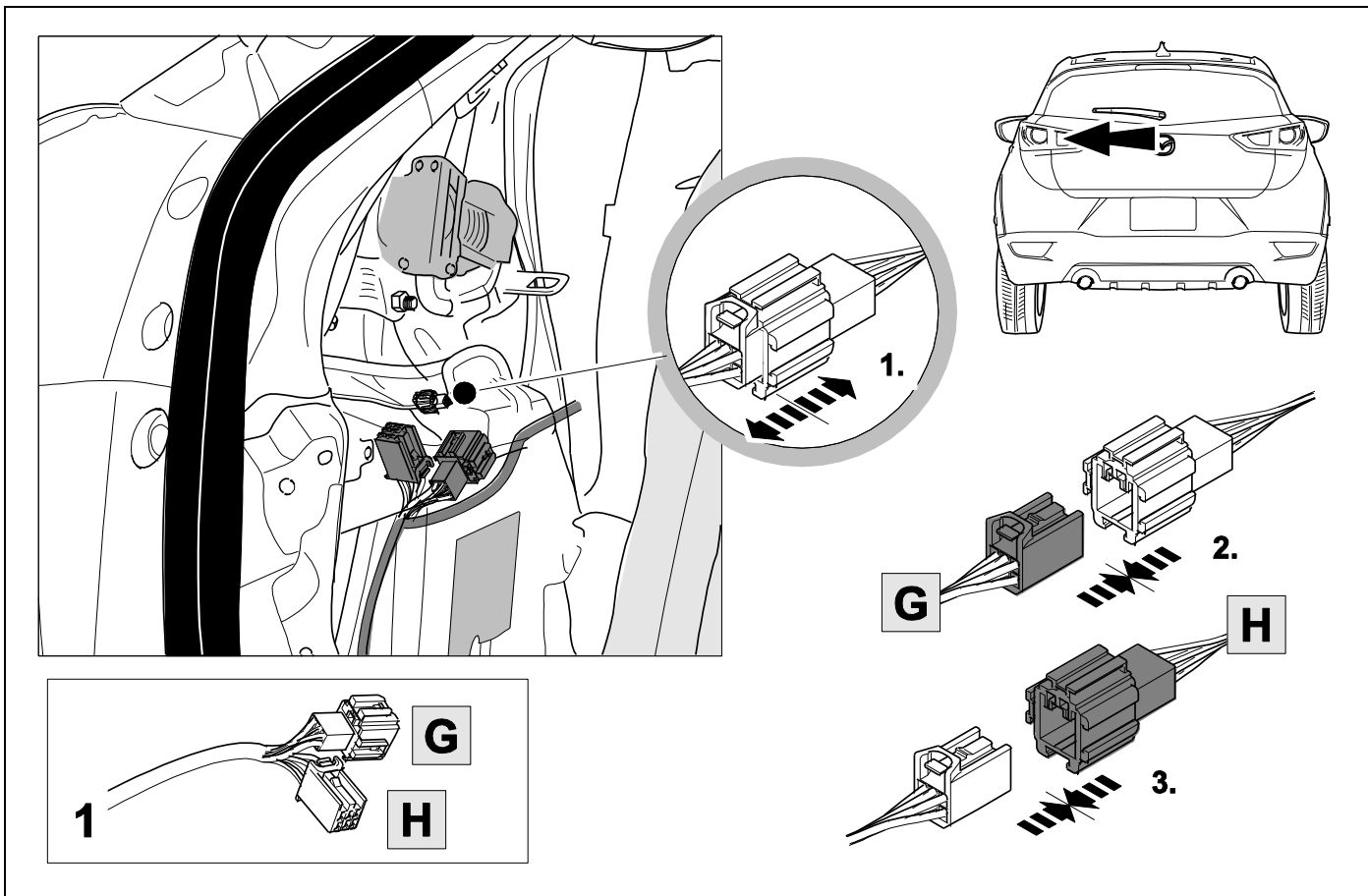

13

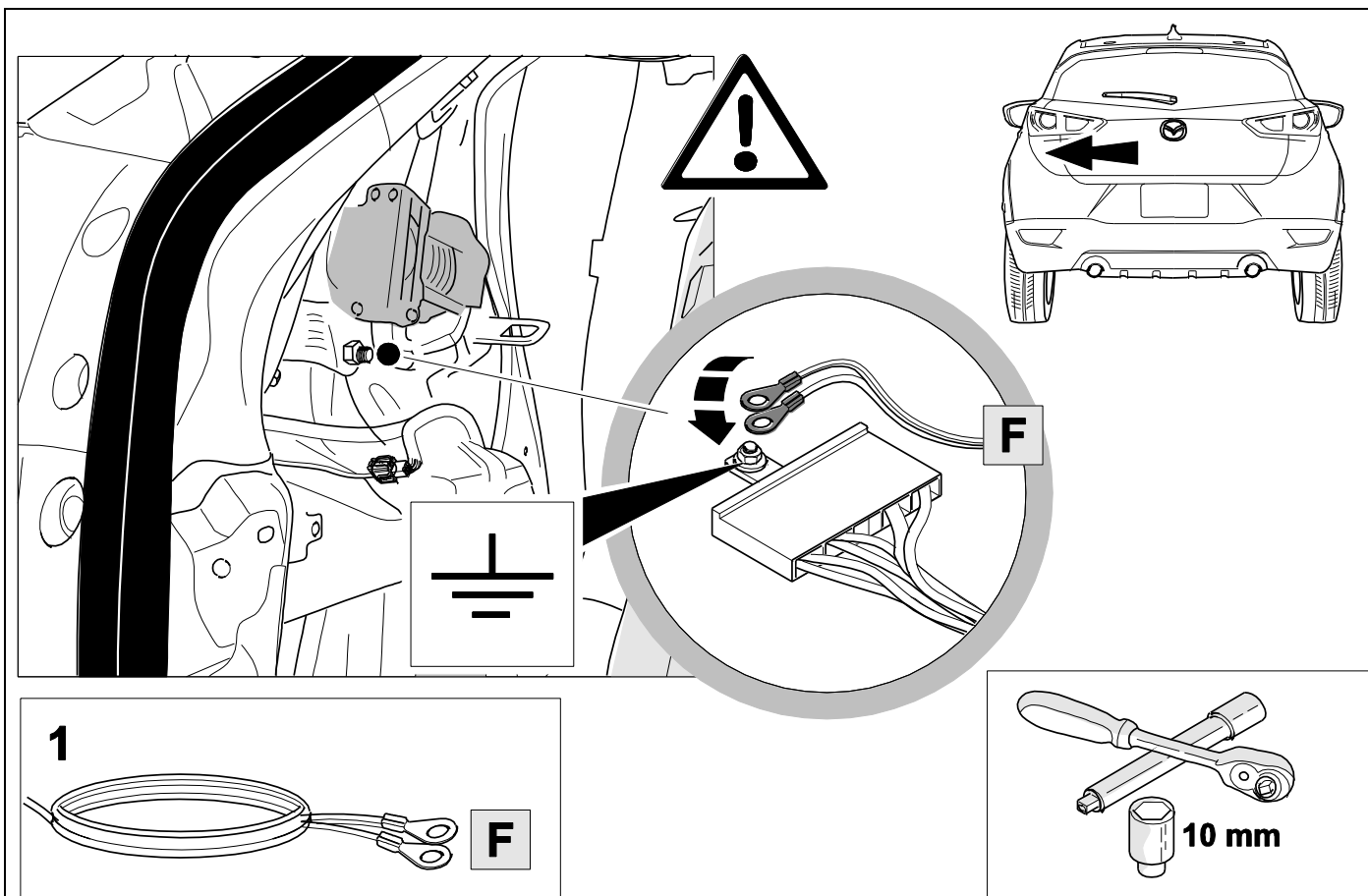

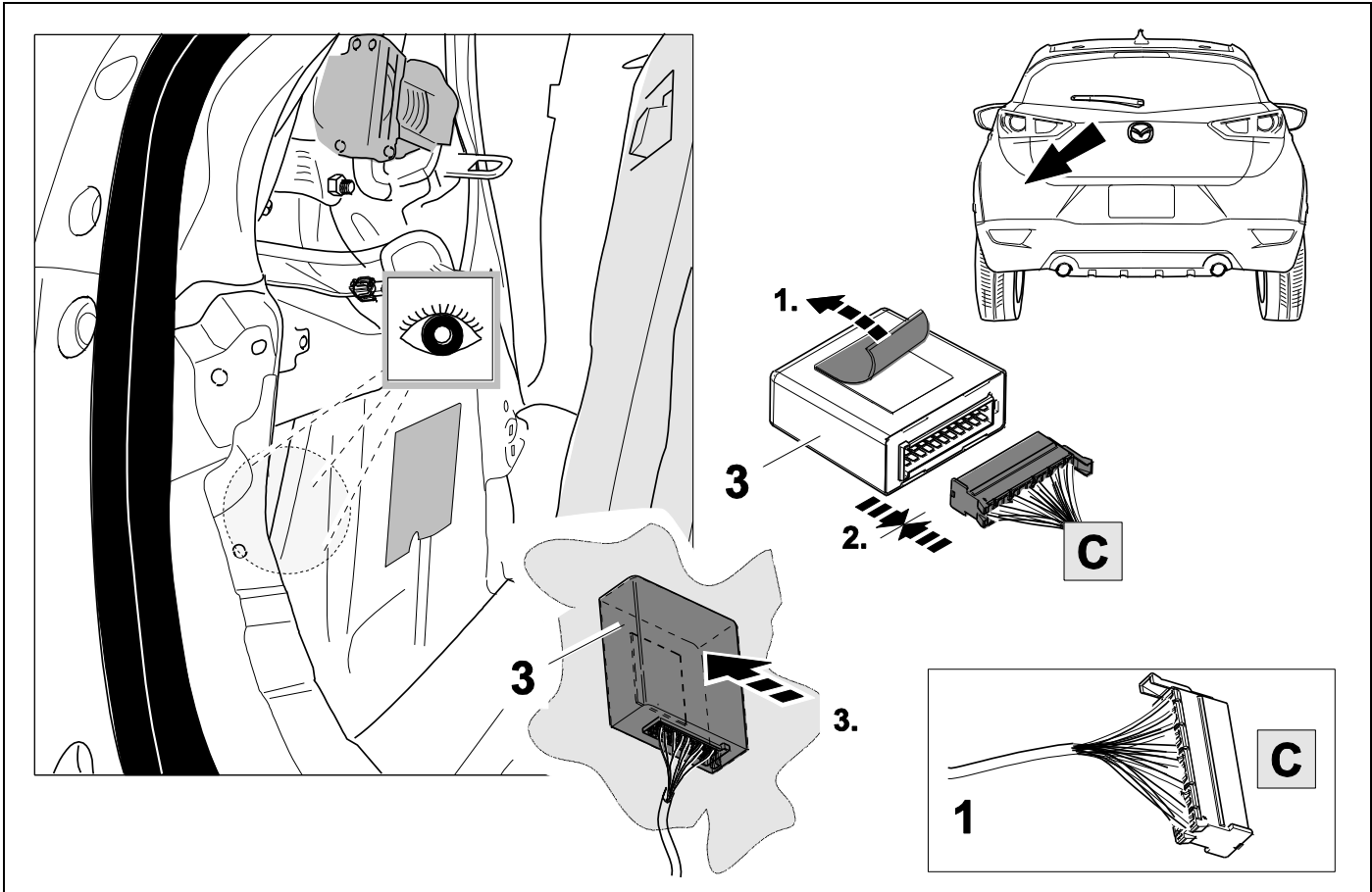

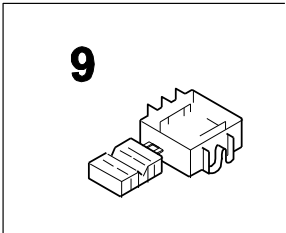
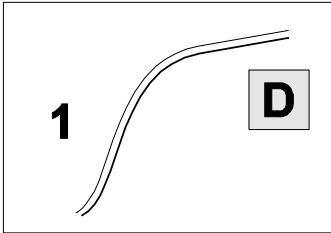
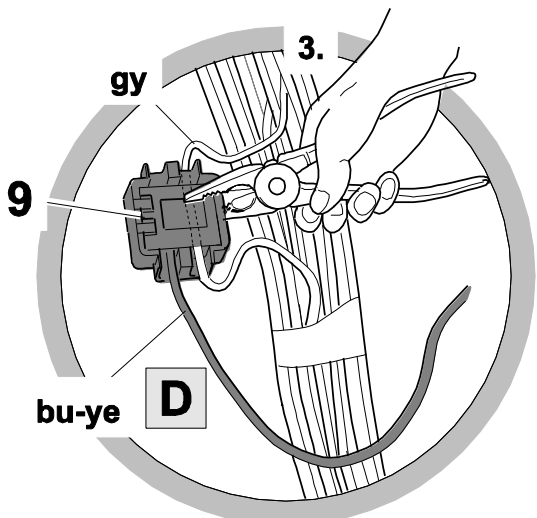
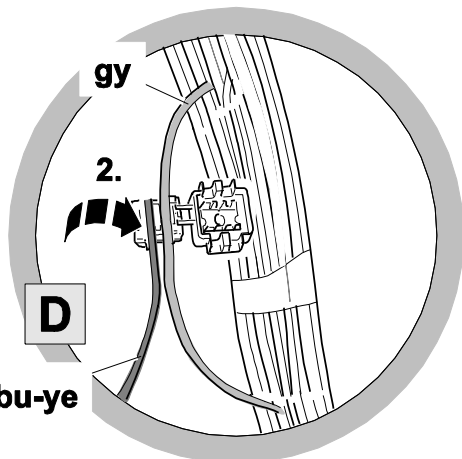
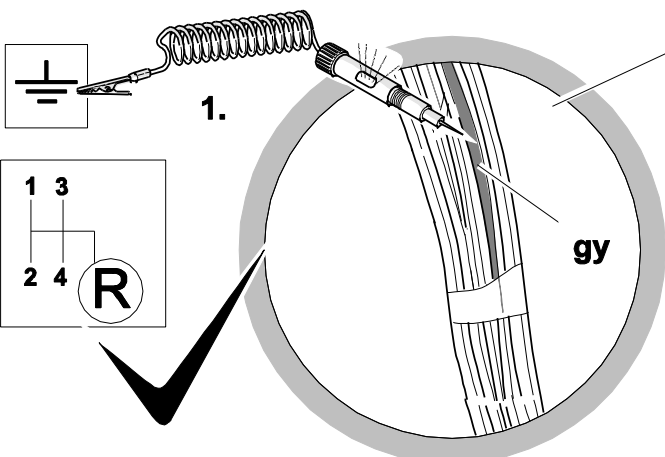
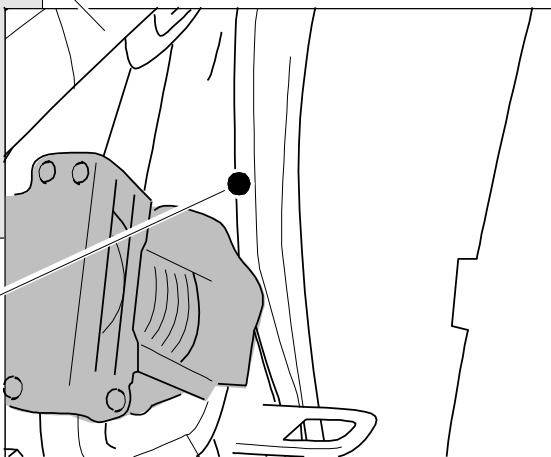
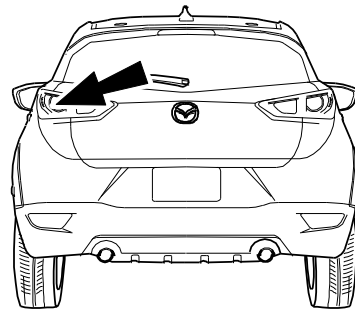



OPTION 1

MAZDA 2 (02/17 >>) GLX
(MMODK4W7A***W2)

MAZDA 2 (03/15 - 01/17)
(JMMODJ2H***W1)

MAZDA CX3 (03/15 >>) GLX

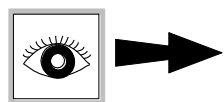

17

OPTION 2

MAZDA CX3 (03/15 - 02/17)
(JMODKJ2H***W1)

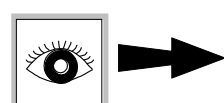

18 + 19

OPTION 3

MAZDA 2 (02/17 >>)
(MMODJ3H***W2)

MAZDA CX3 (02/17 >>)
(MMODJ3H***W2)

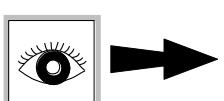

18 + 20



OPTION 1

Vehicles without PDC

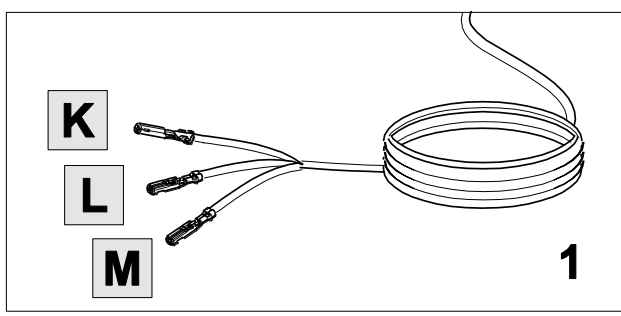
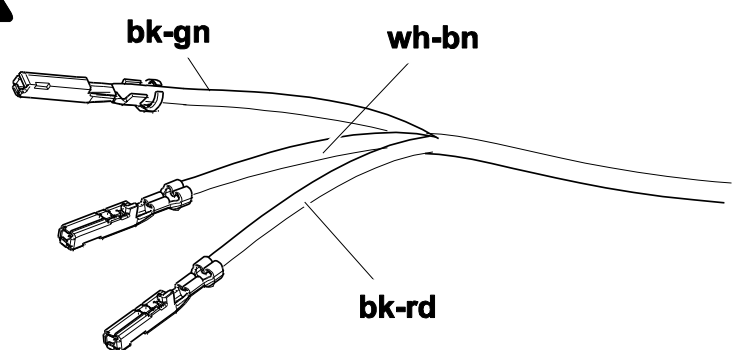
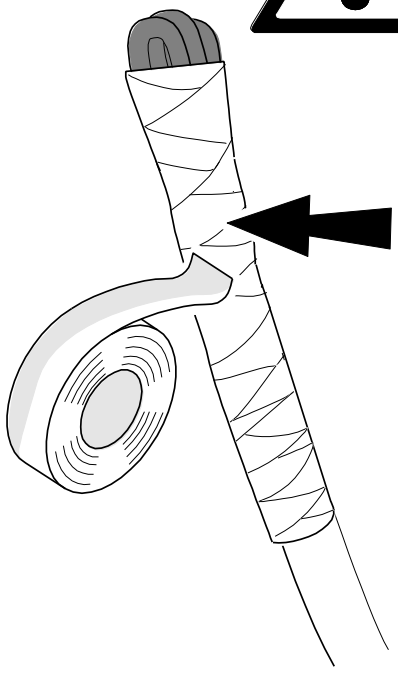

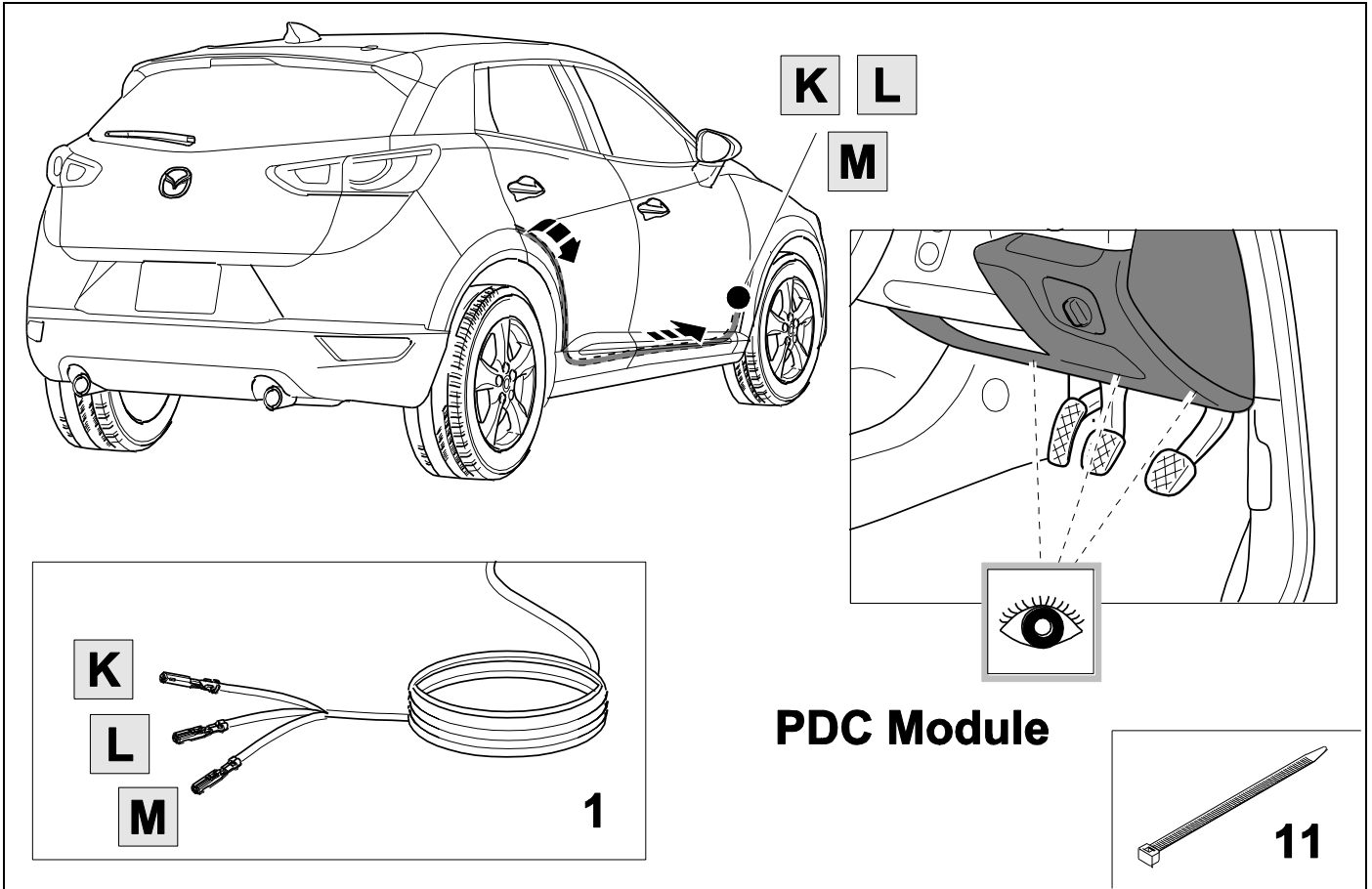

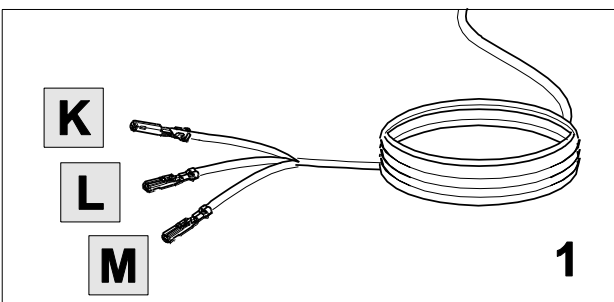
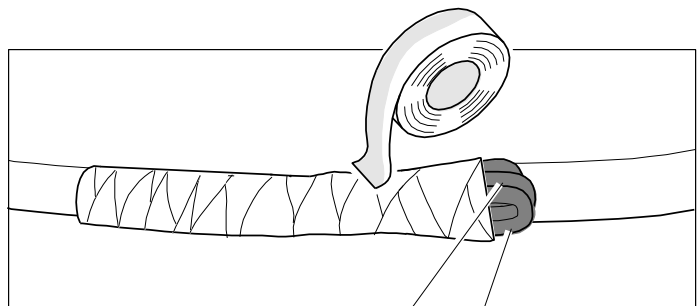
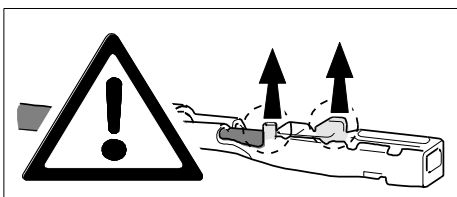
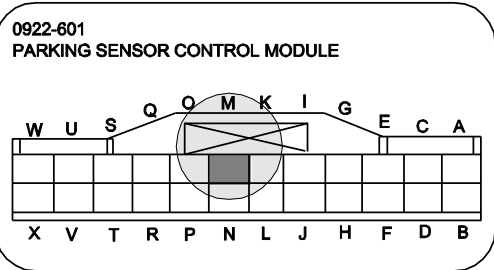
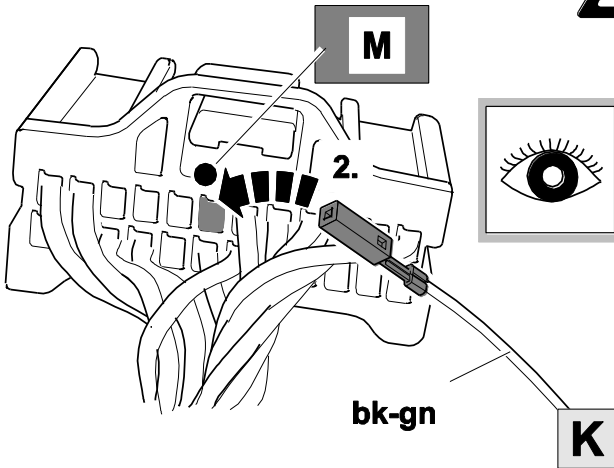
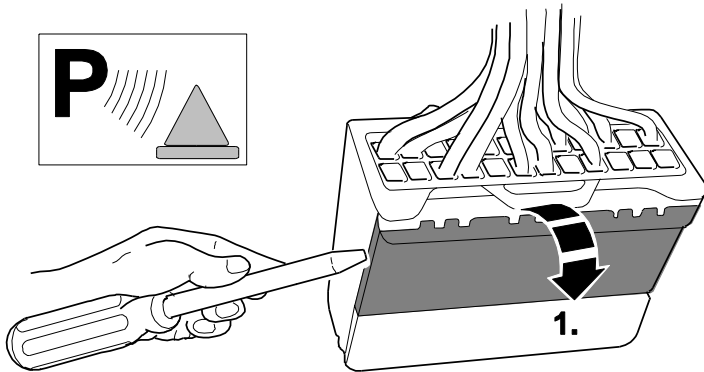
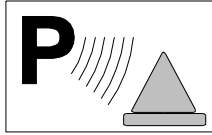
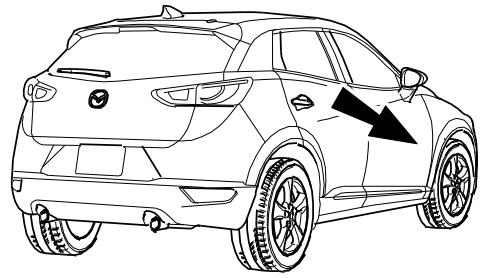

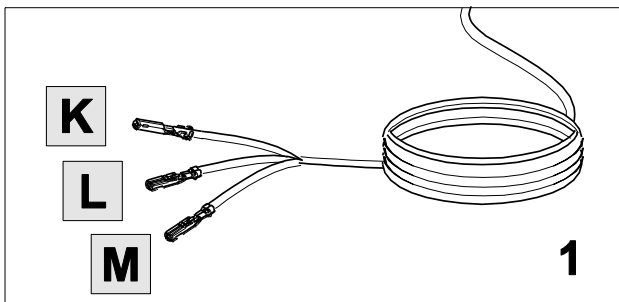
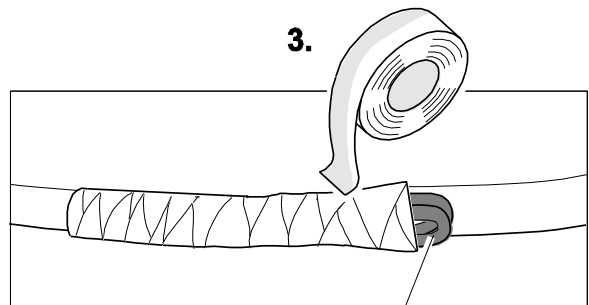
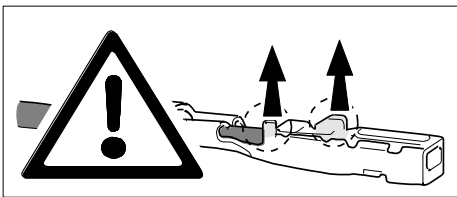
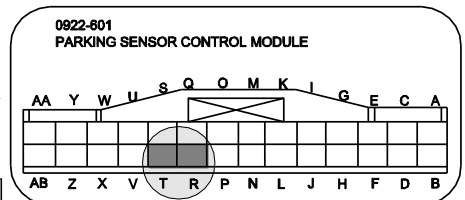
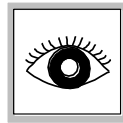
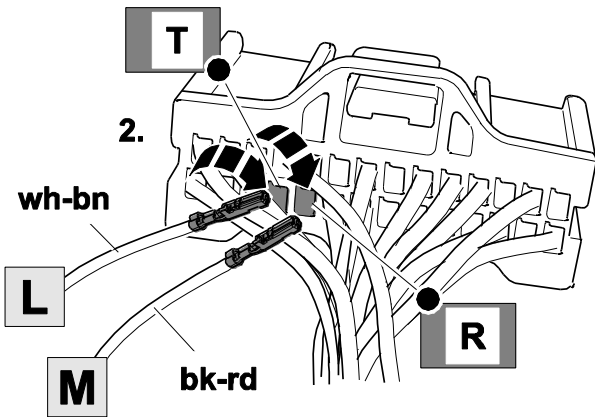
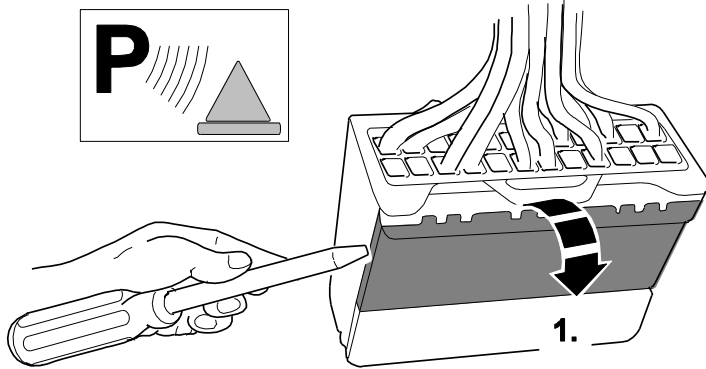
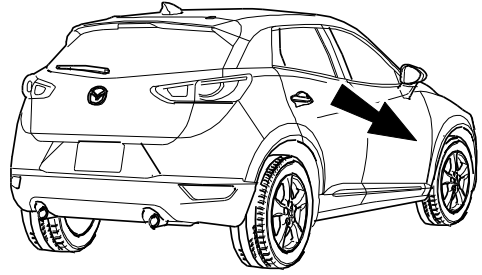

21



27

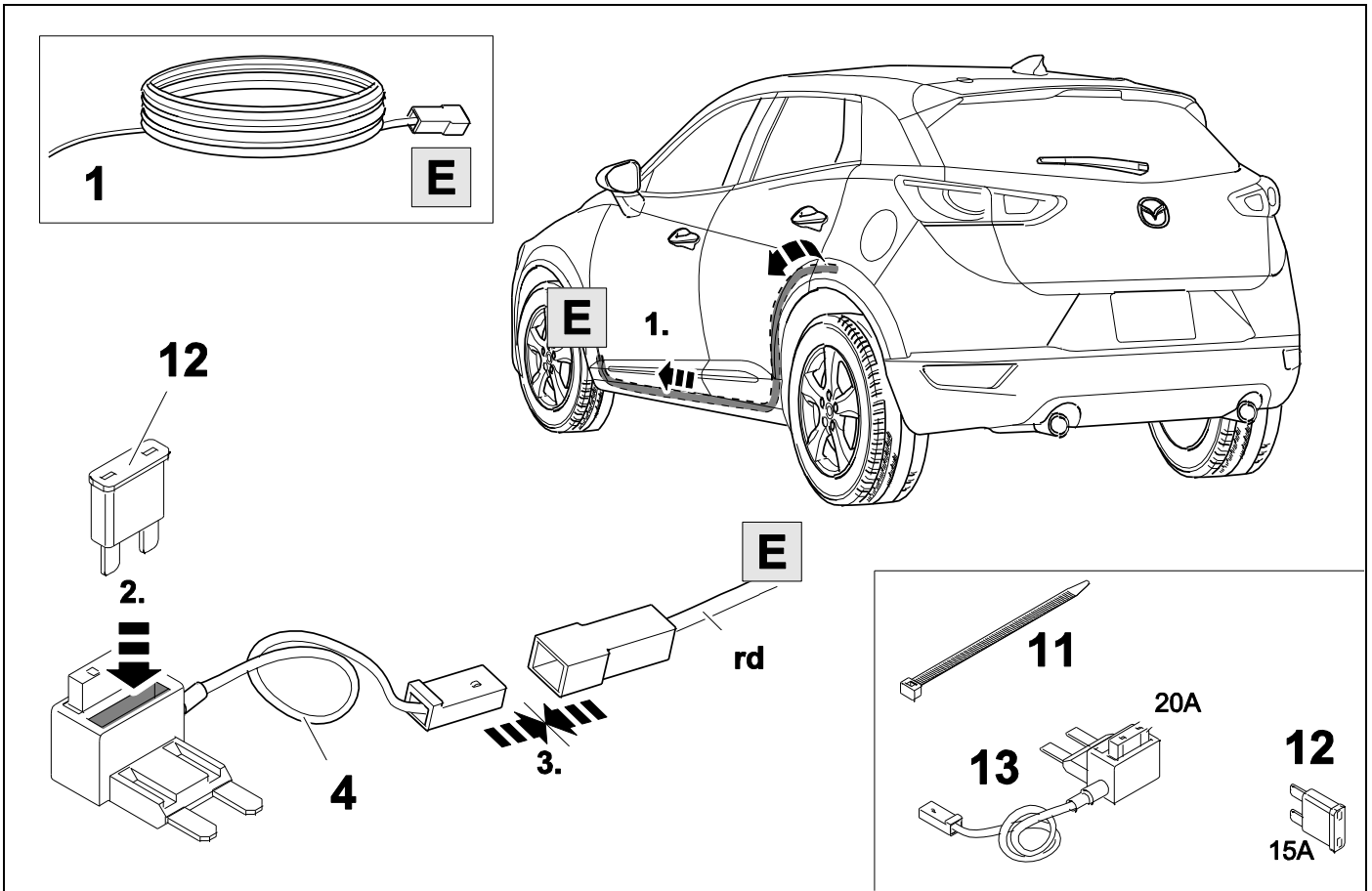

22

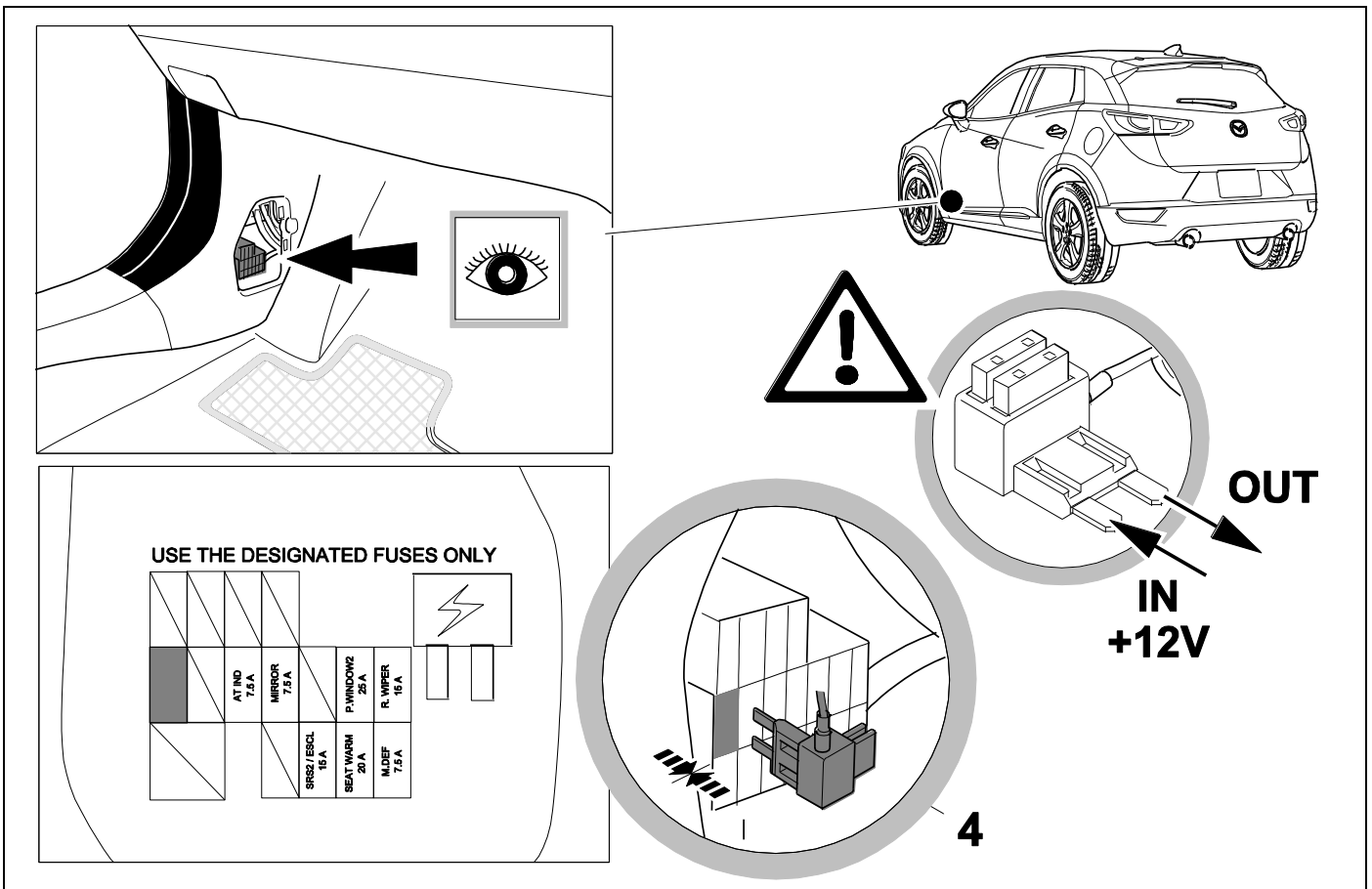

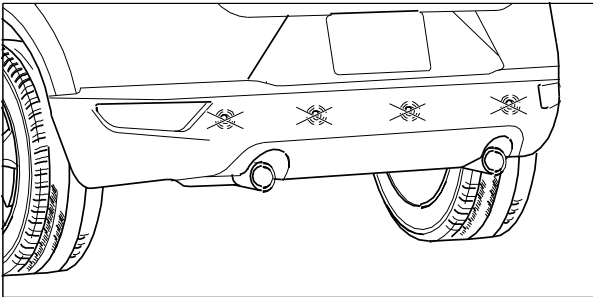
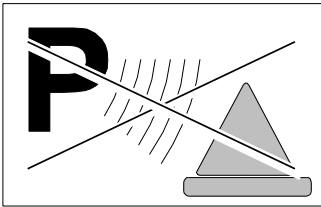
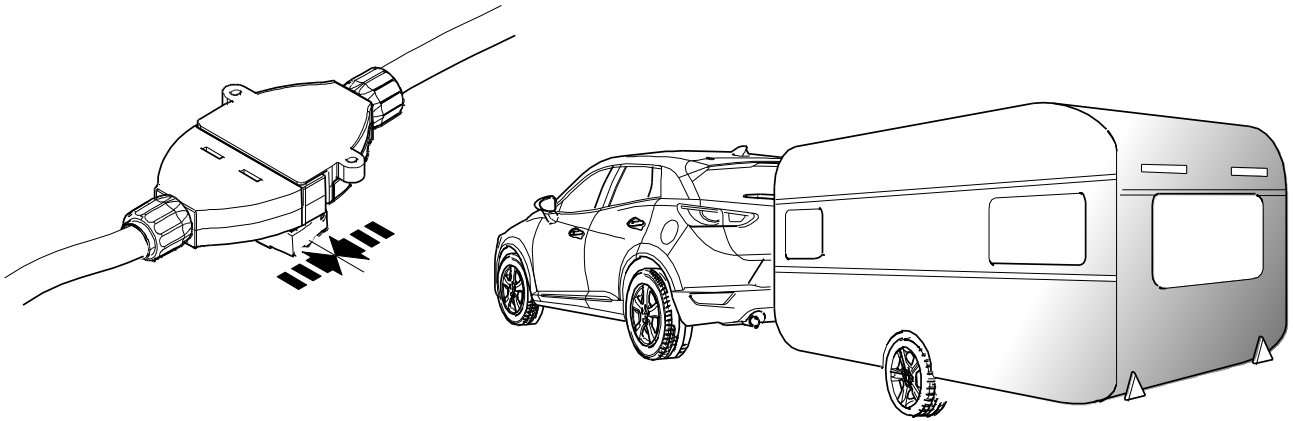

The PDC or SCBS-R system is not active while the parking brake is engaged.



In order to test automatic PDC and SCBS-R deactivation while stationary, plug in a trailer light tester or trailer and ensure the parking brake is disengaged. A deactivation message will be displayed as shown.

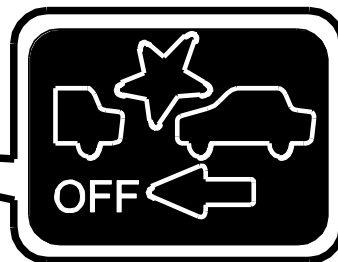
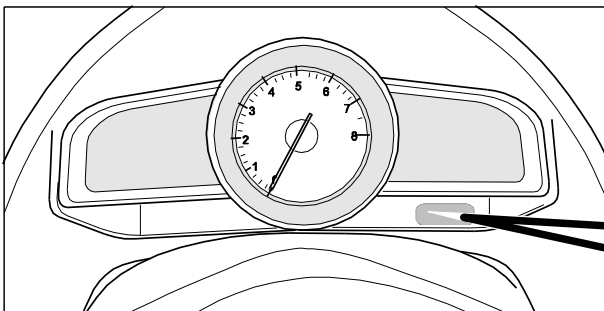



**BRAKE
CONTROLLER
PREPARED**

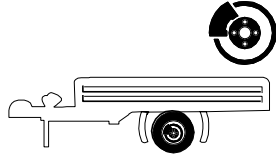

Trailer Brake Preparation

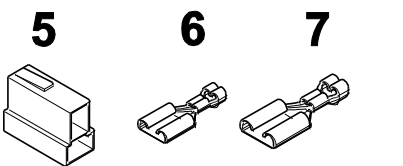
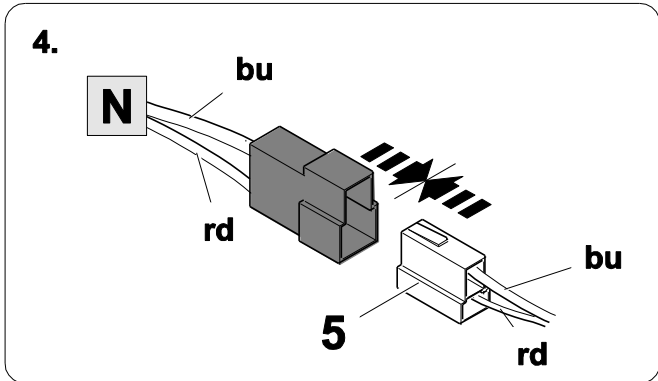
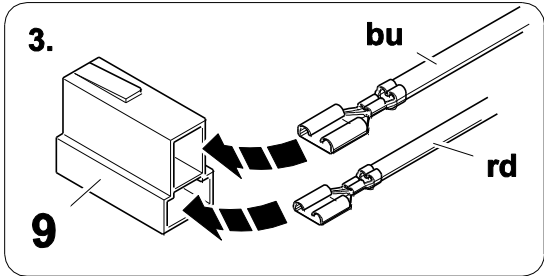
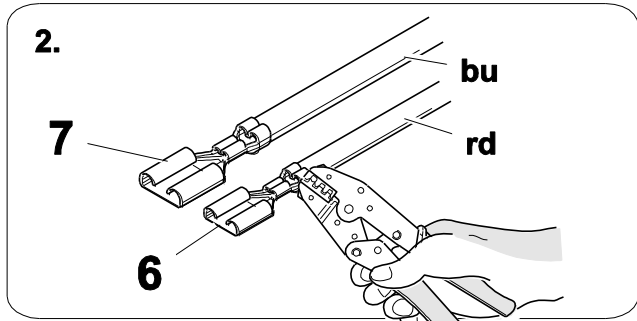
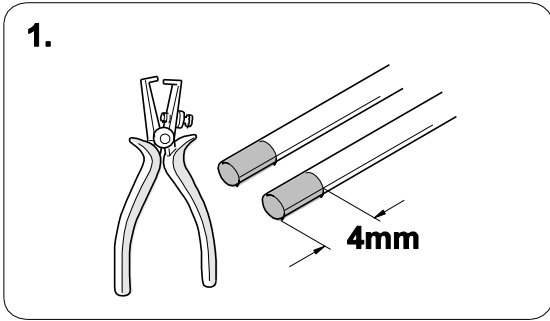
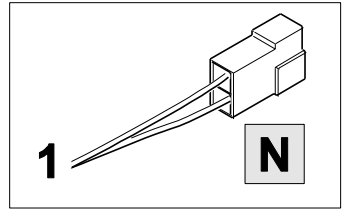

APPROVED, TESTED AND CERTIFIED TO BE USED WITH THE SPECTRUM BRAKE CONTROLLER.

USE OUR BRAKE CONTROLLER CONNECTION HARNESS 529008EJ

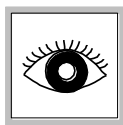
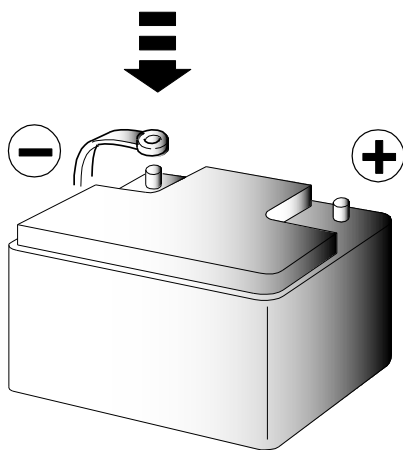

26

CHECK ALL LIGHTING FUNCTIONS

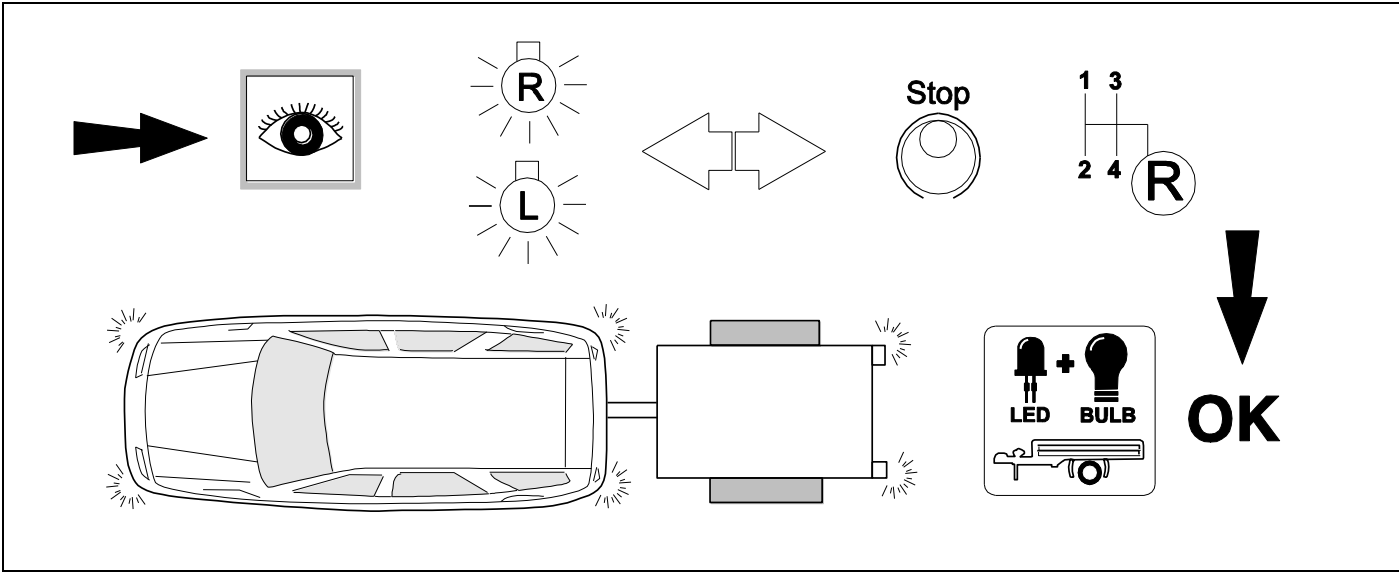

27

CHECK BULB OUT DETECTION

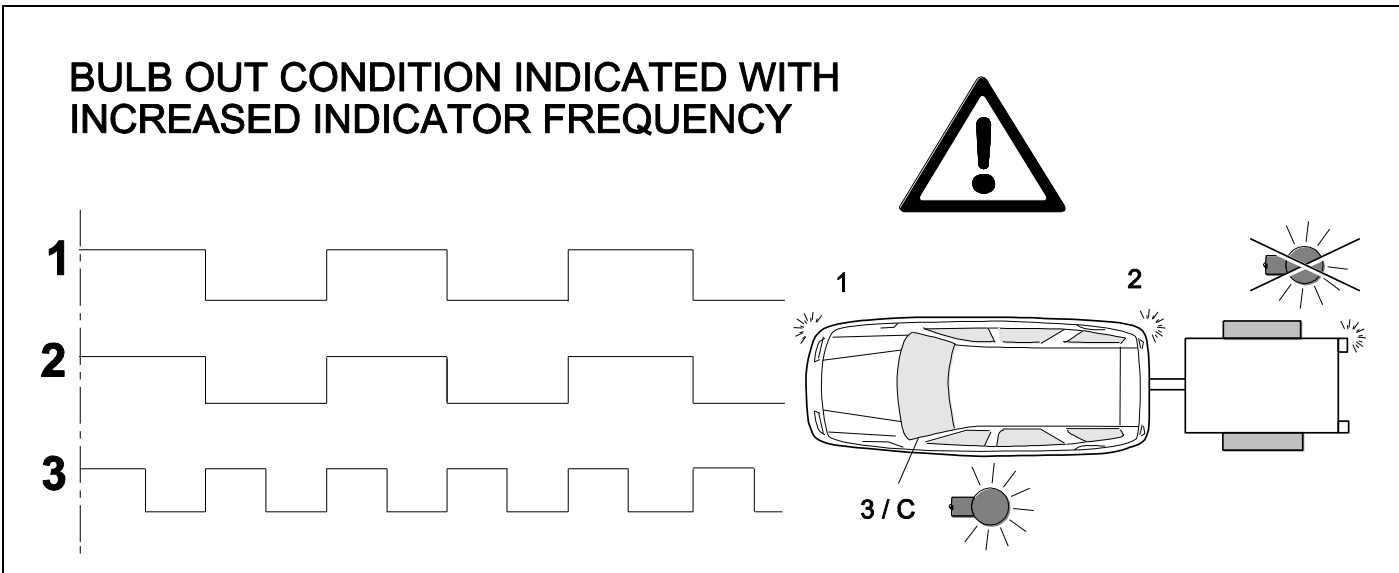

28

👁️ ⇒ 19

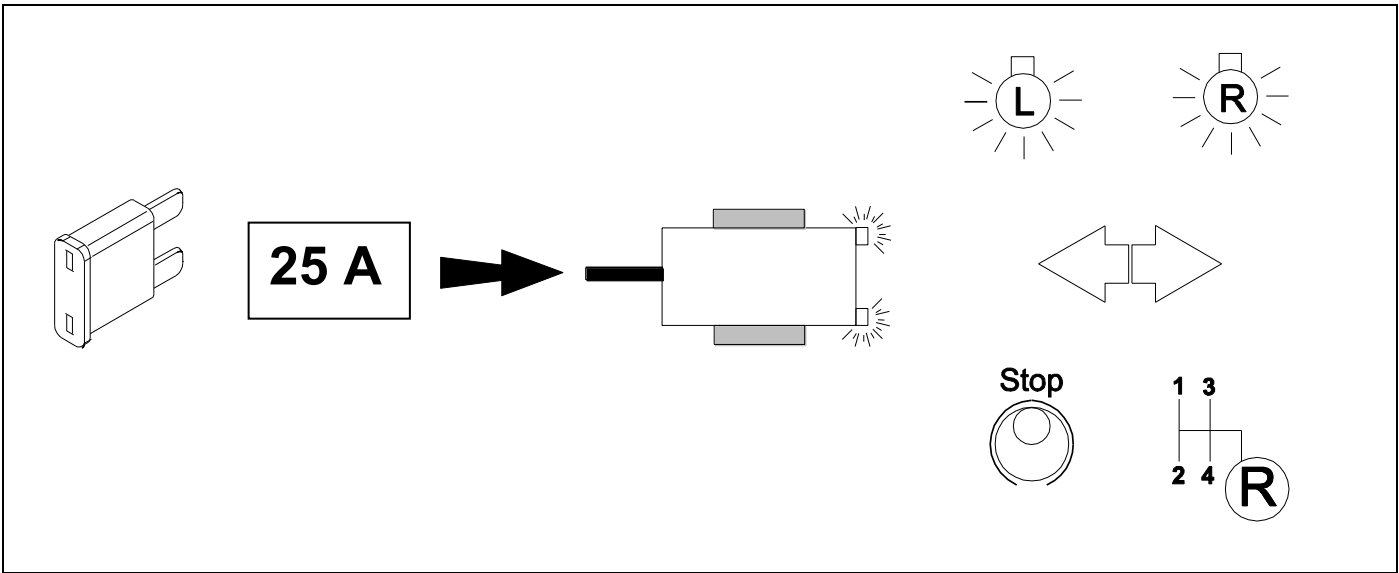

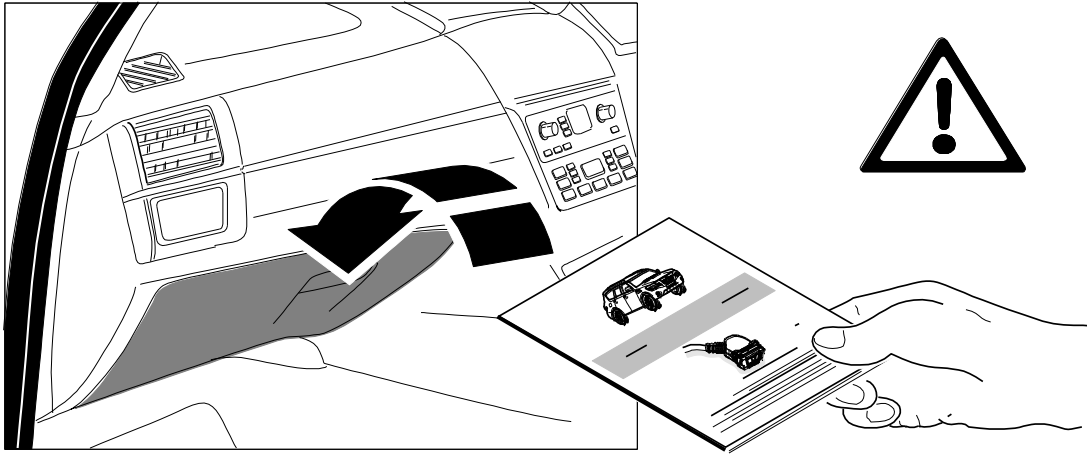

Subject to change in terms of construction, equipment and colour, and may contain errors.
The information and illustrations are non-binding.