

750023EJ

Mazda BT50

12/11 >>



SCAN FOR
LATEST
INSTRUCTIONS

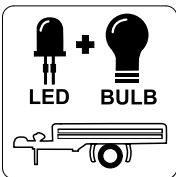
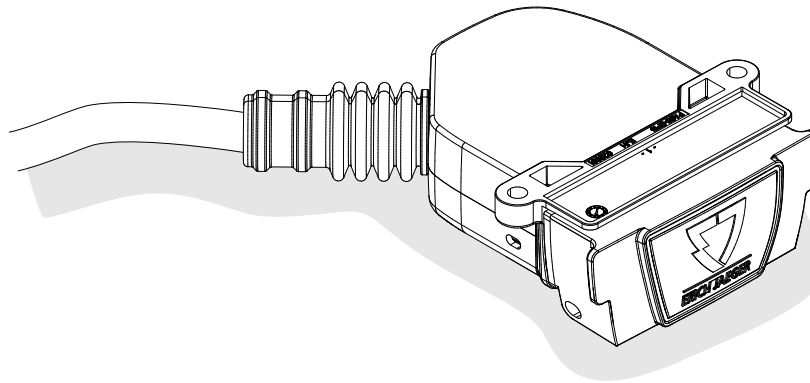

Reference:

The following information must be reviewed before beginning the assembly:

The installation instructions are to be thoroughly read.

The installation should be carried out by qualified personnel with the relevant technical knowledge. The vehicle manufacturers' current technical notices and information on retrofitting must be followed. The removal and replacement instructions found in the current repair manuals must be followed.

It must be ensured that the vehicle is technically suitable for the installation of a trailer hitch.

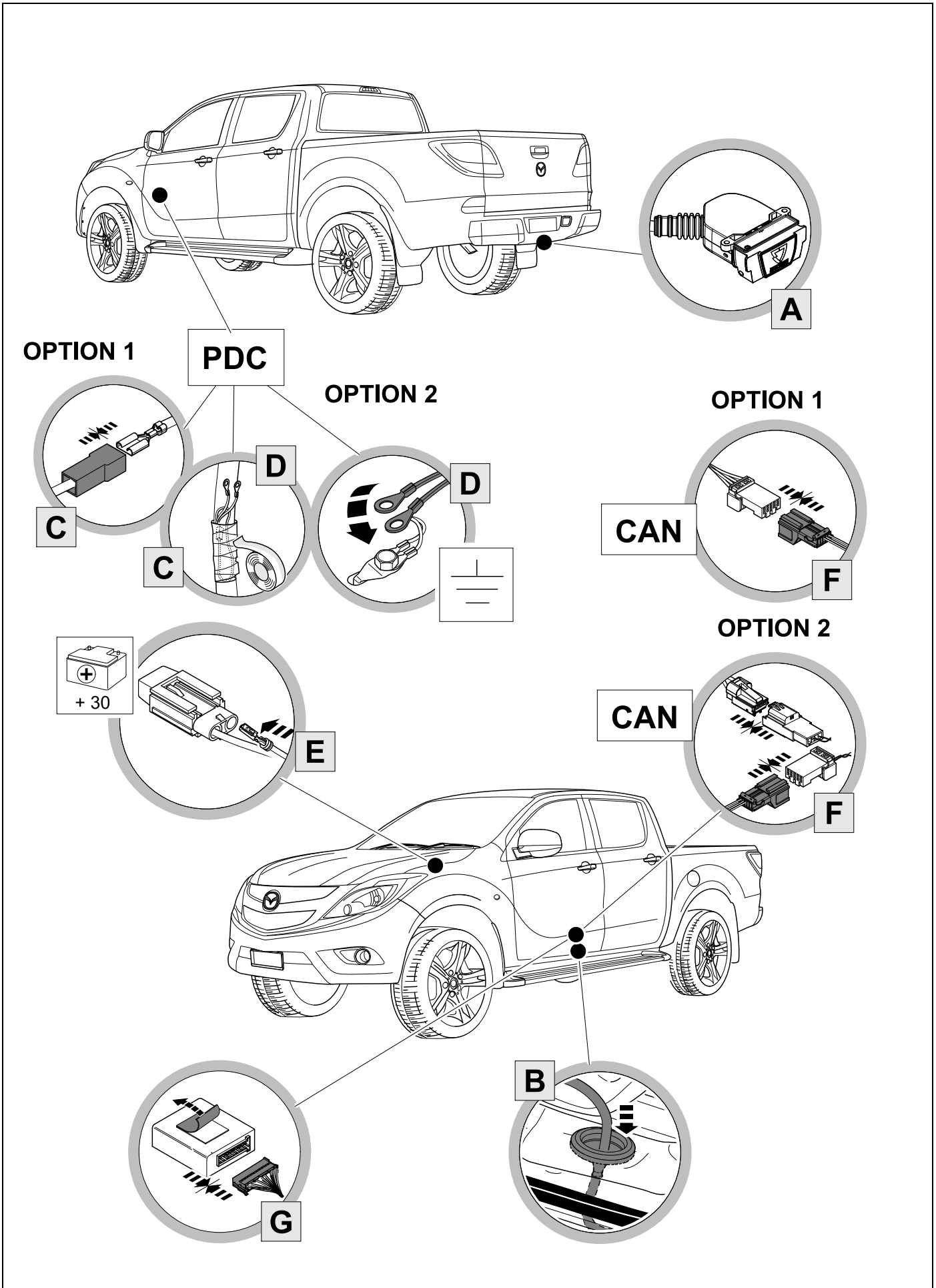

KIT

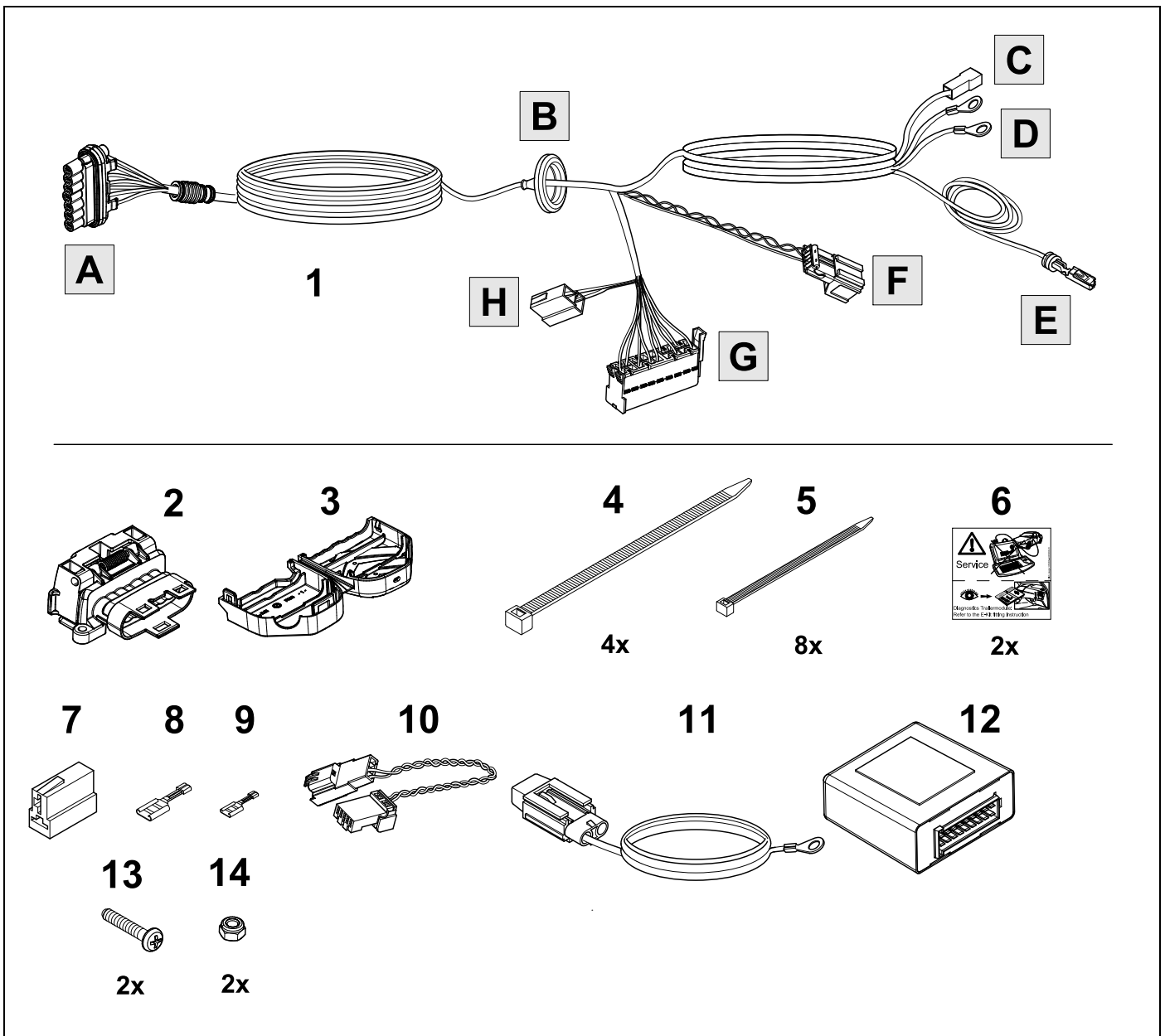

TOOLS

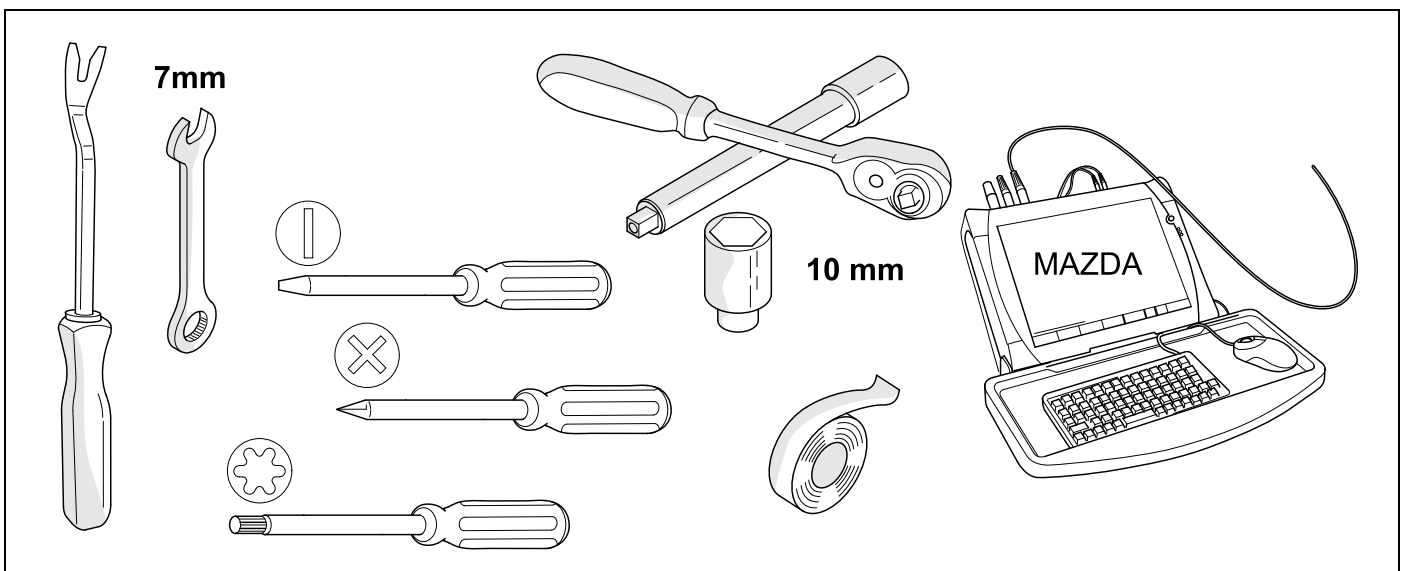

1

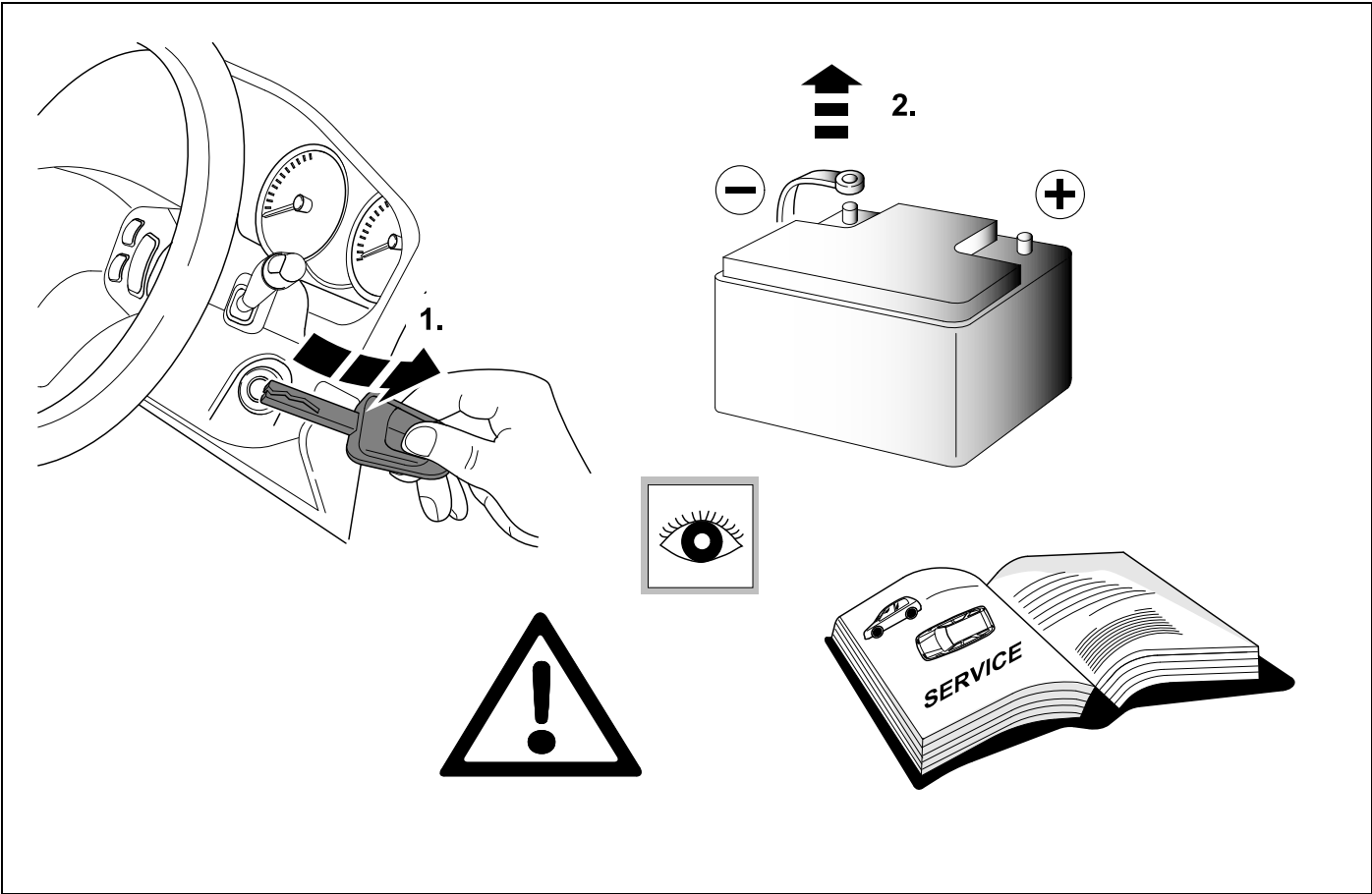

2

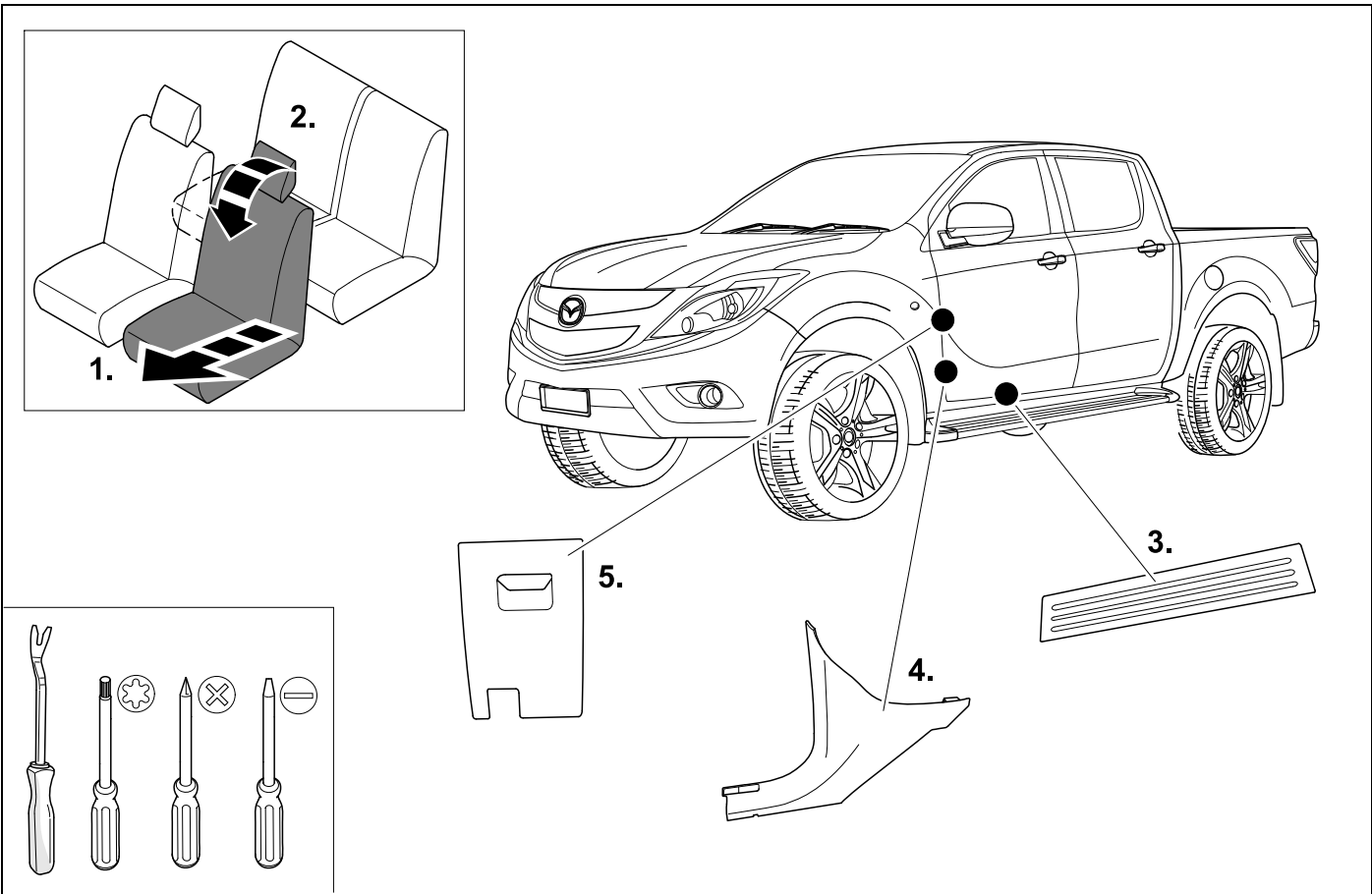

3

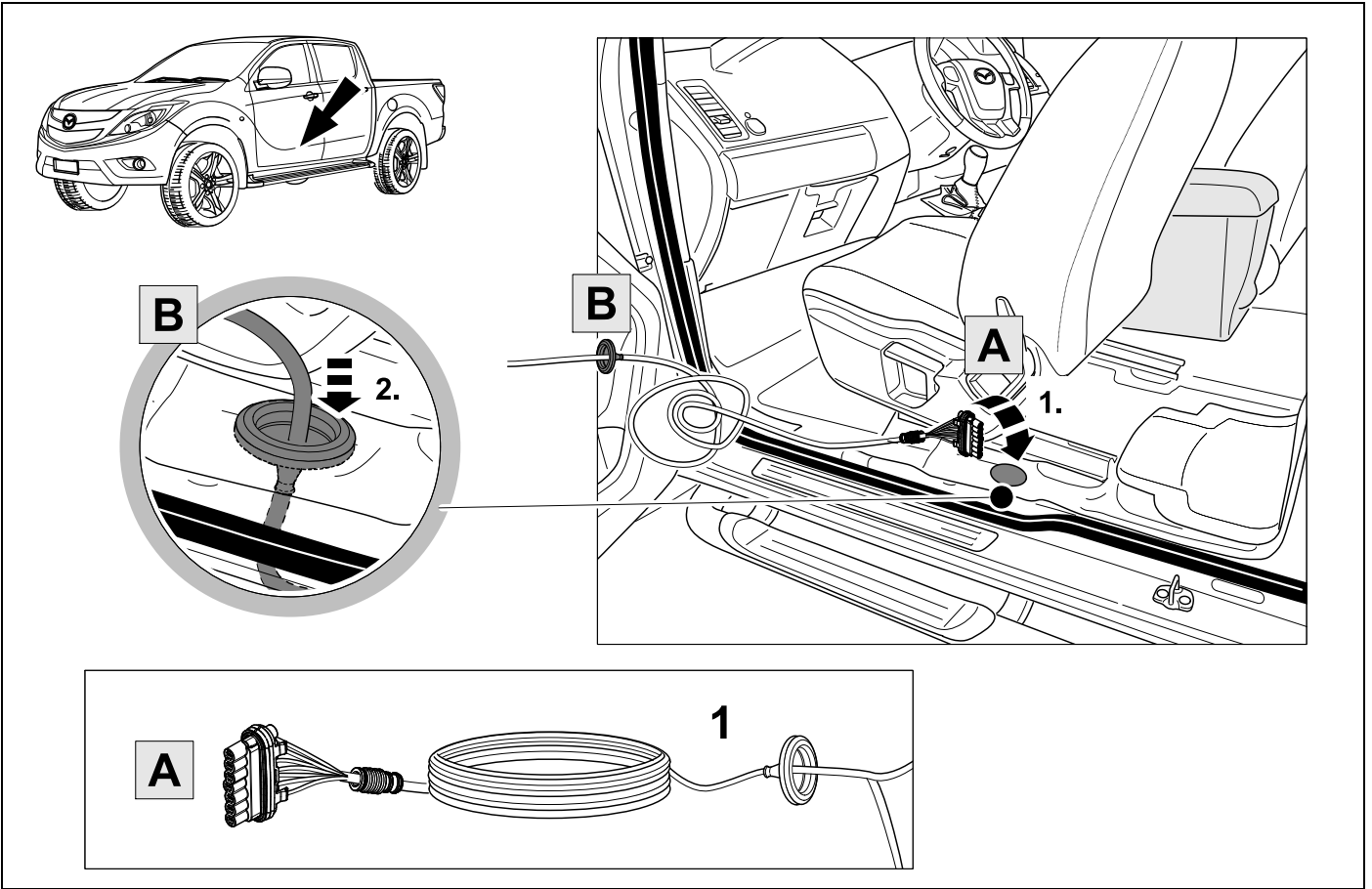

4

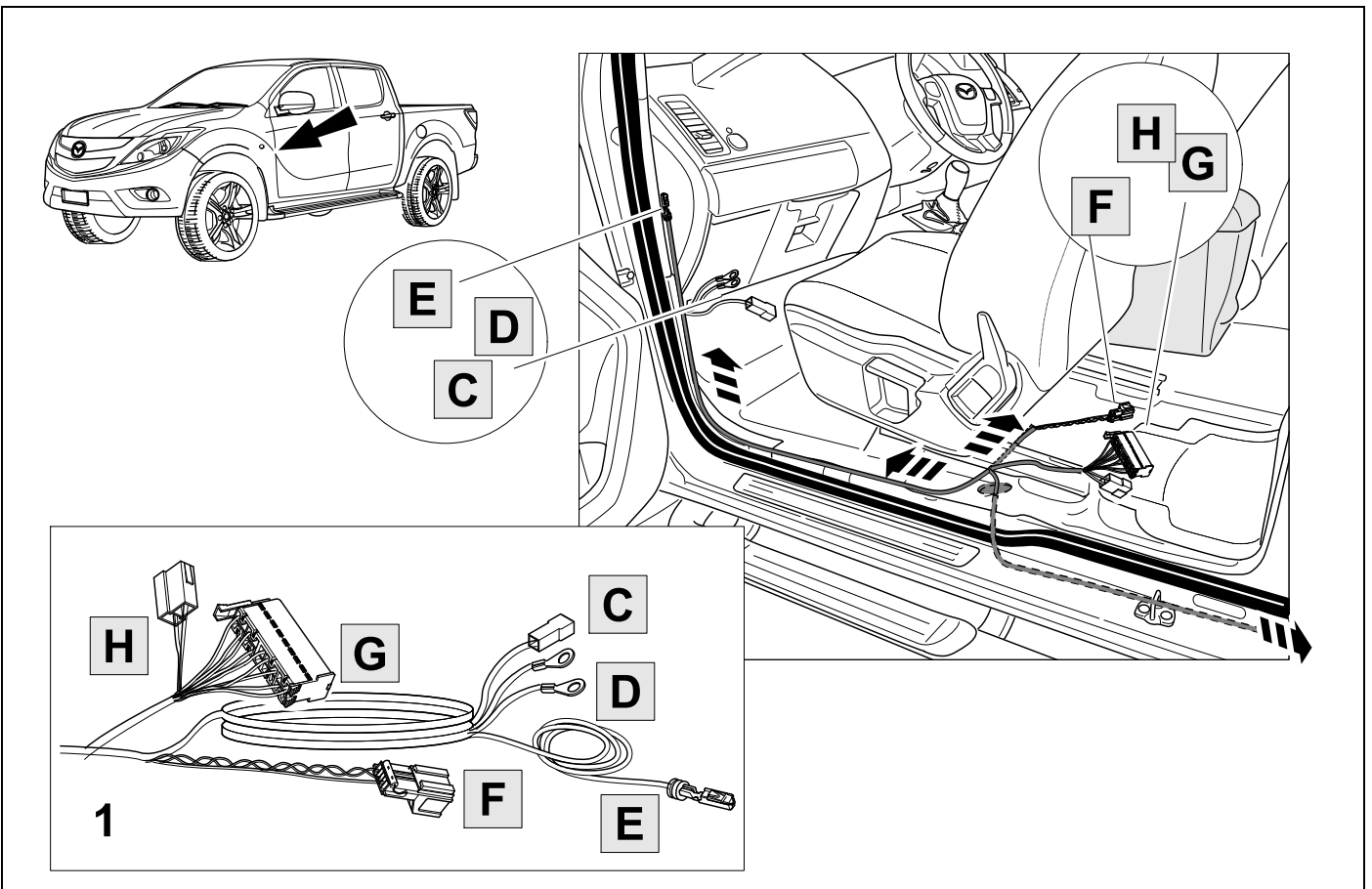

5

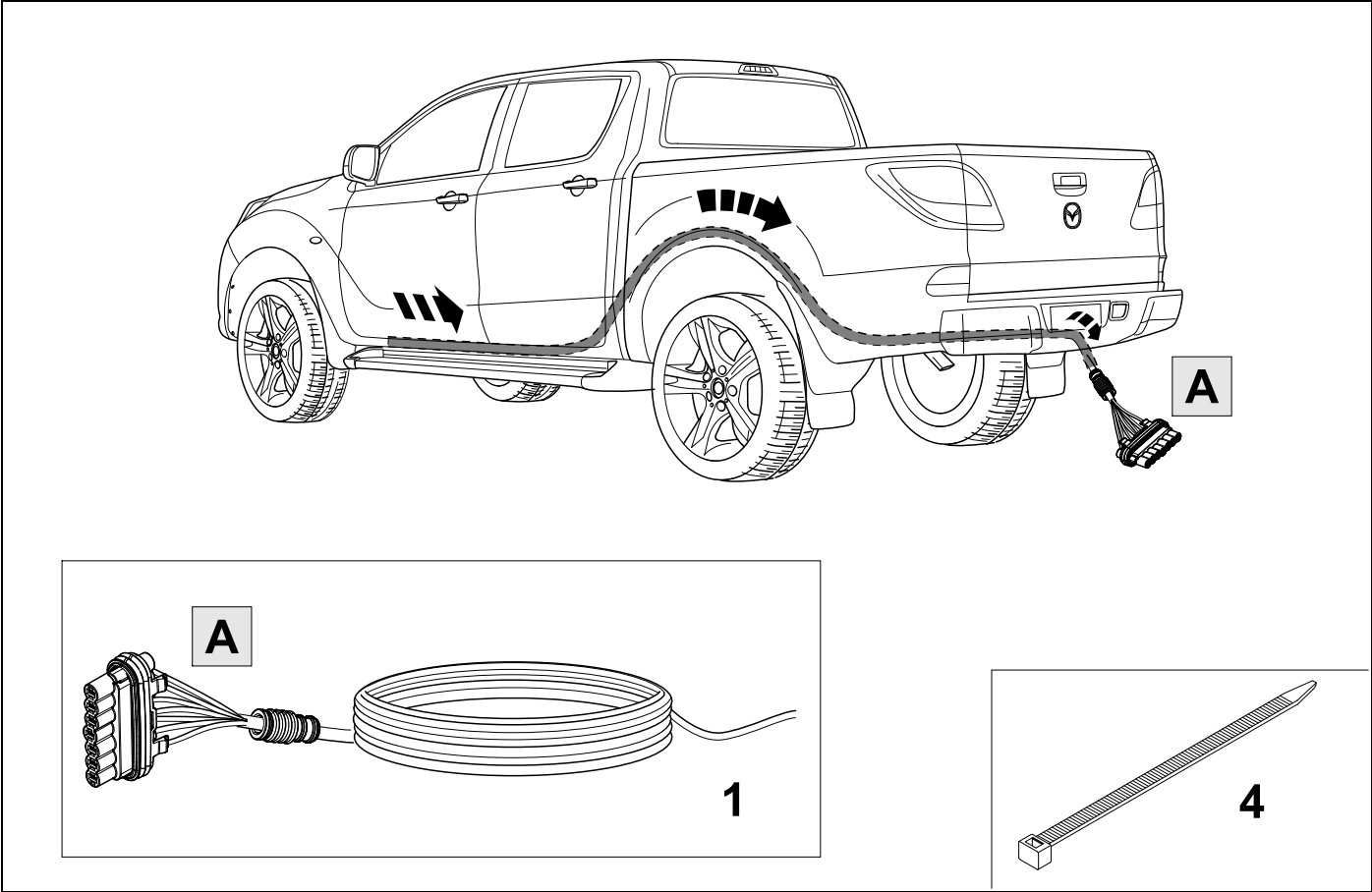

6



8

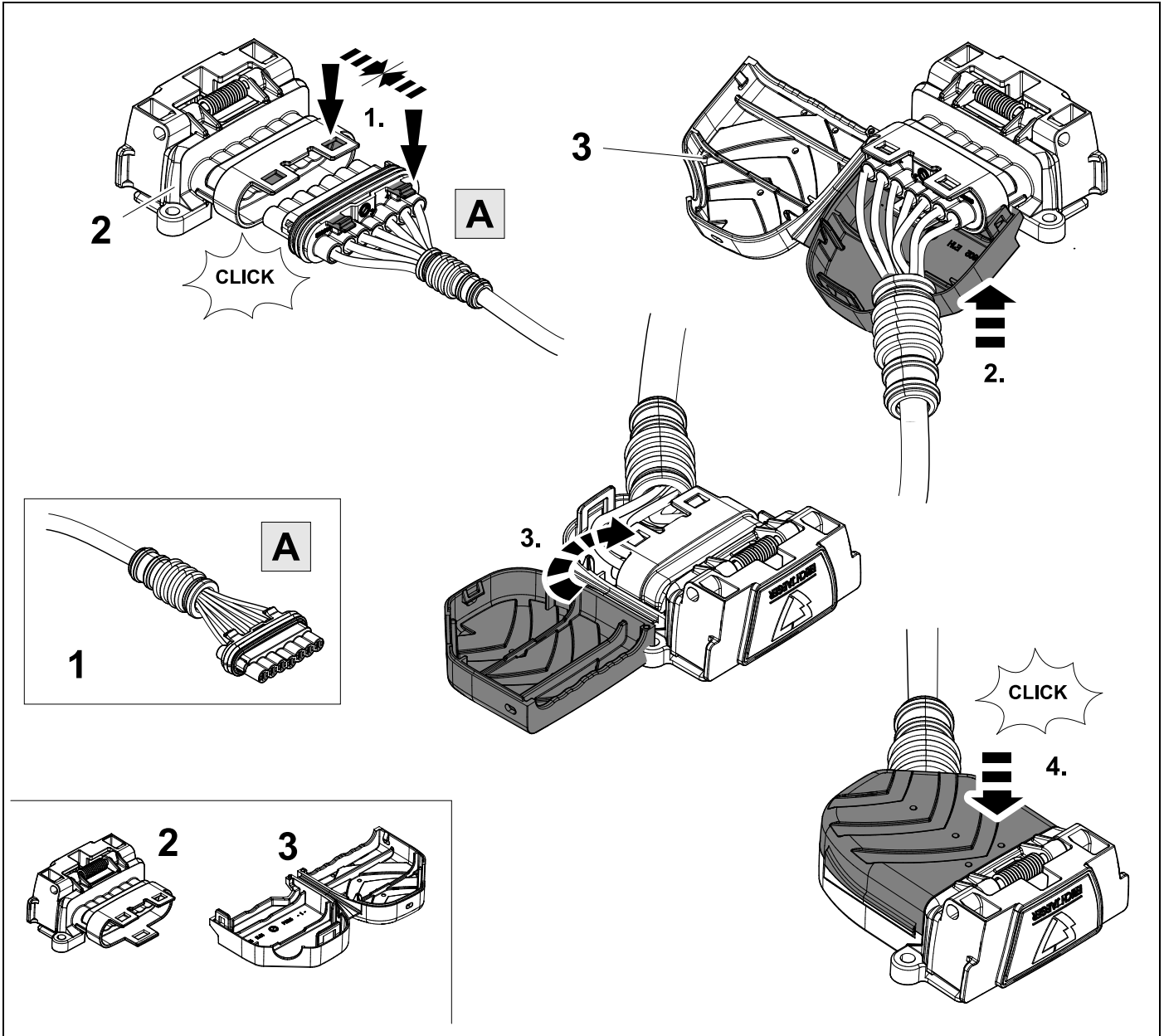

7

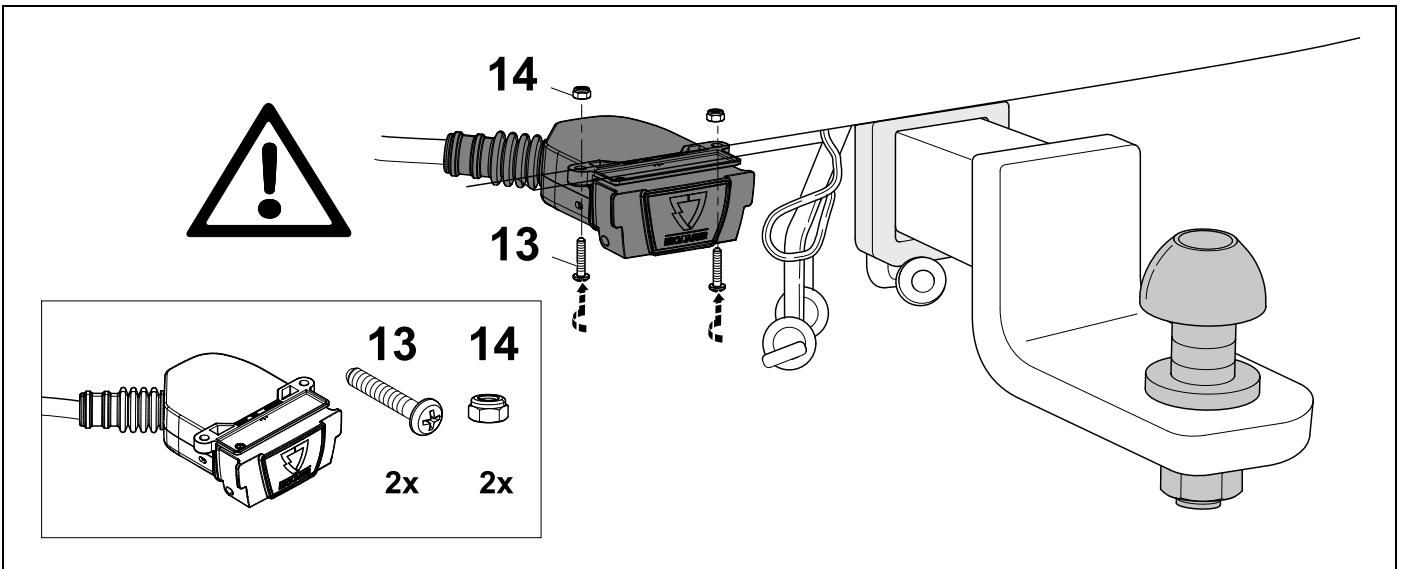

8



9

1	ye	
2	bk	
3	wh	
4	gn	
5	bu	
6	rd	
7	bn	

9 bk wh gy gn rd bu ye bn pu or no

	black	white	grey	green	red	blue	yellow	brown	purple	orange	not occupied
--	-------	-------	------	-------	-----	------	--------	-------	--------	--------	--------------

10

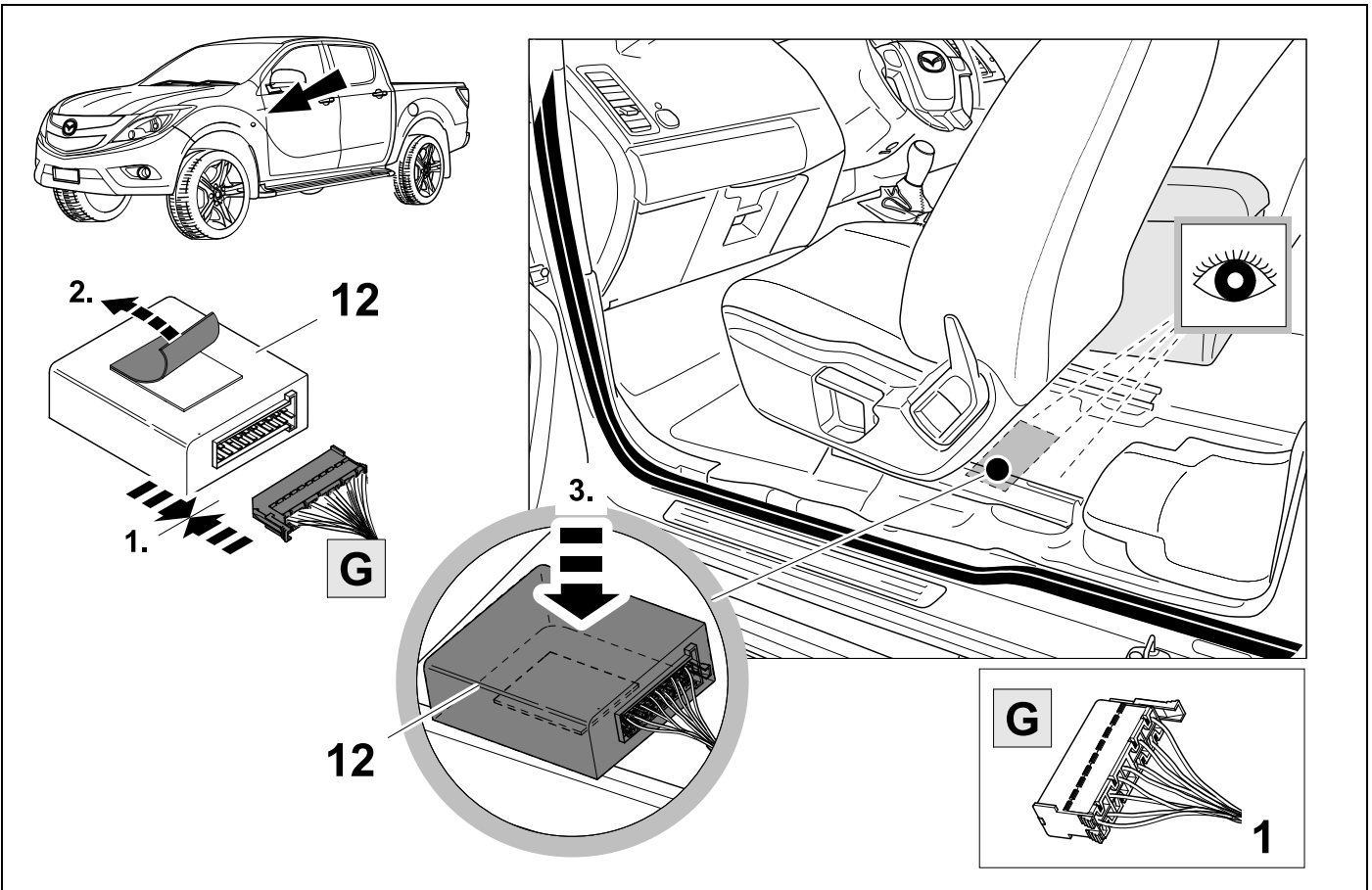

11 OPTION 1



9

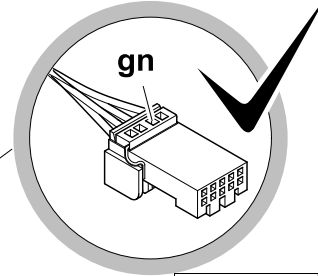
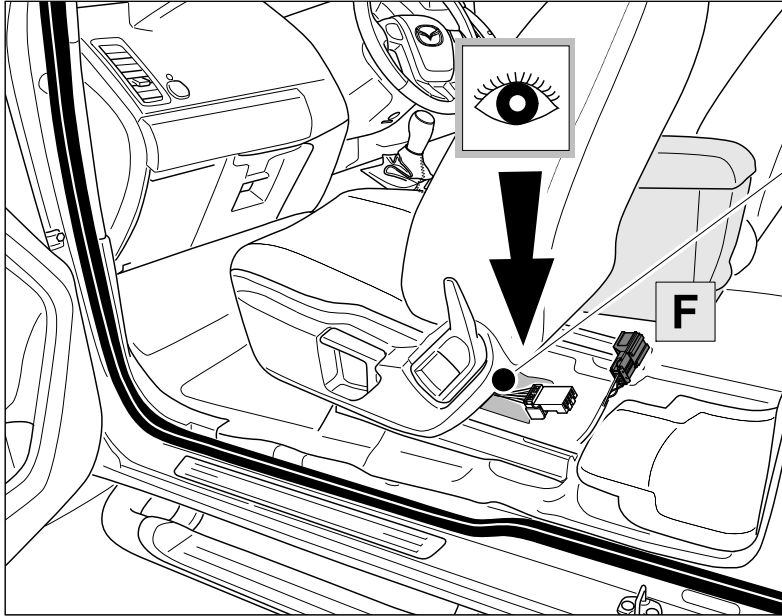
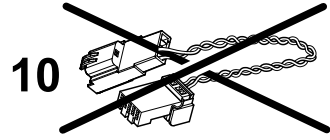
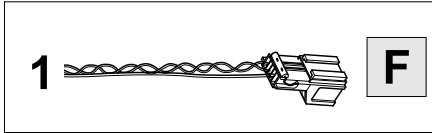
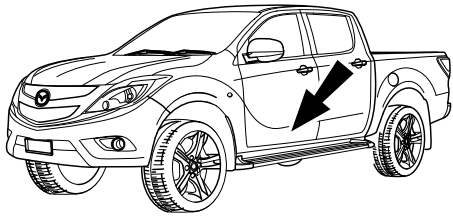

CAN

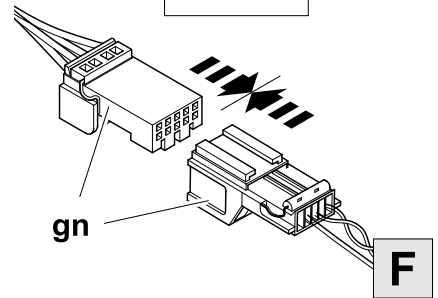

12 OPTION 2



9

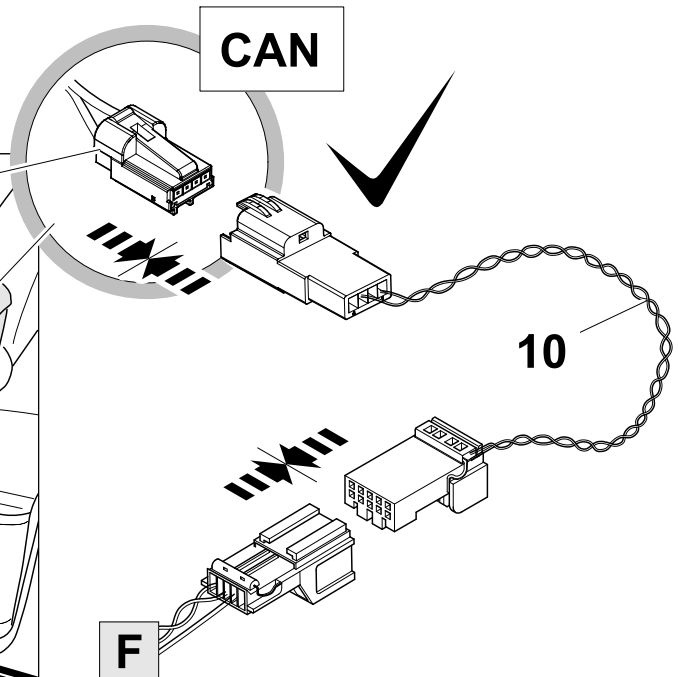
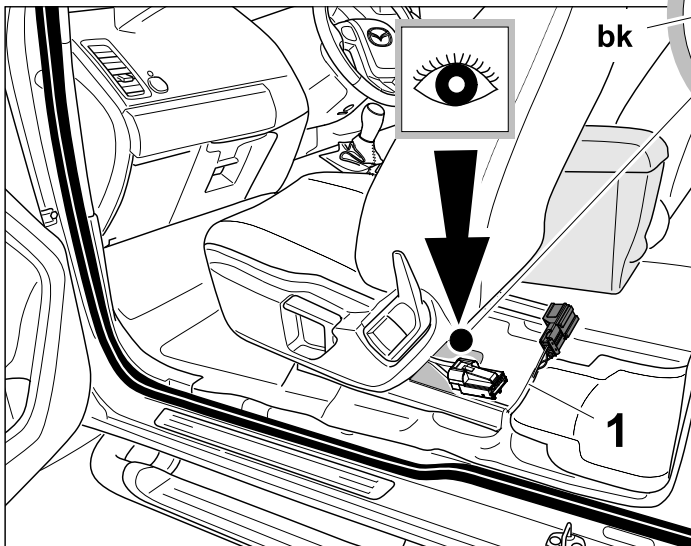
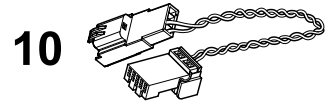
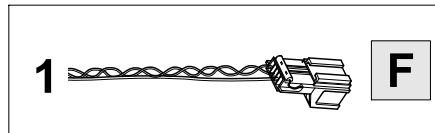
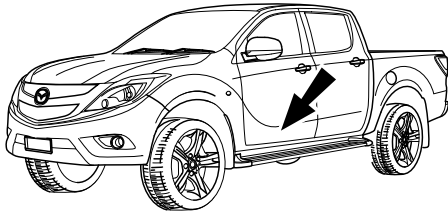

13

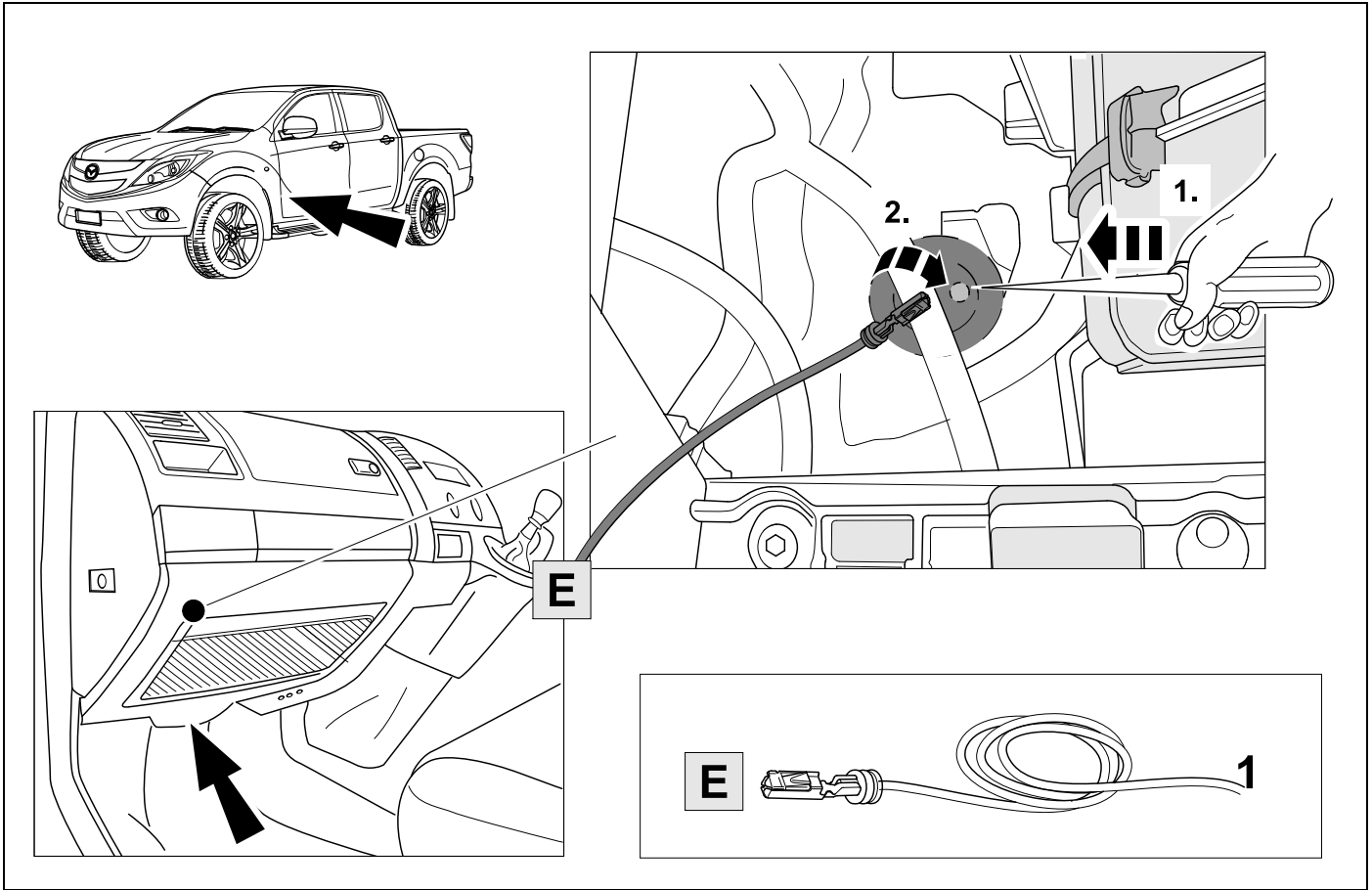

14



25

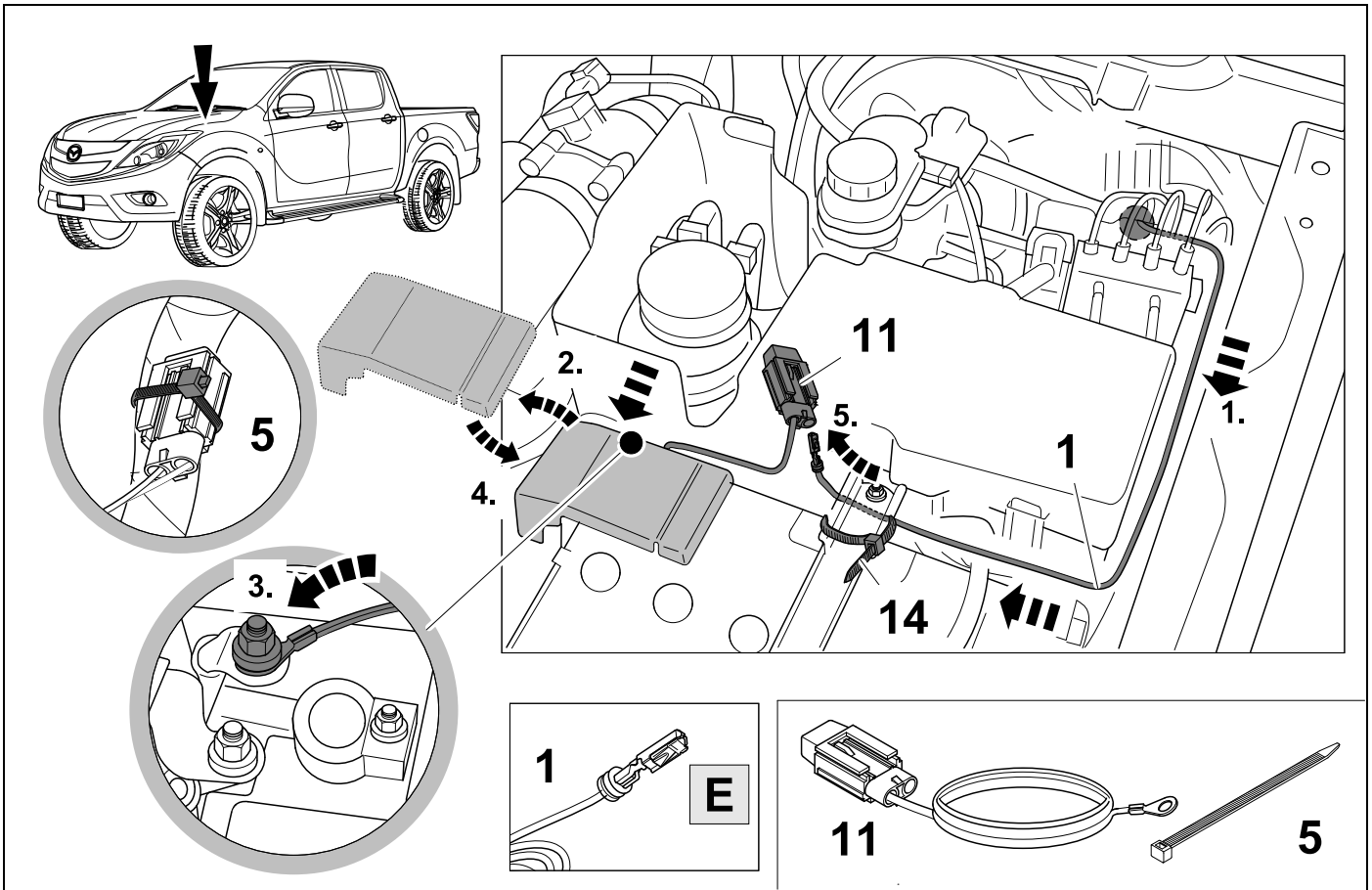

15 OPTION 1



9

With Infotainment system and PDC

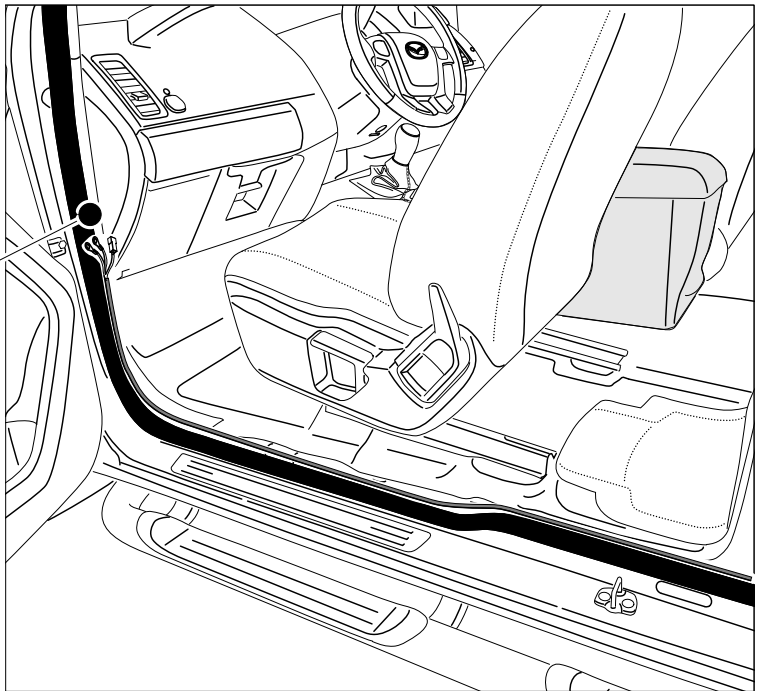
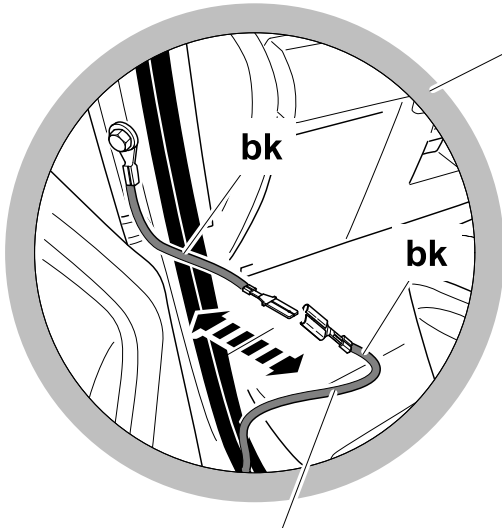
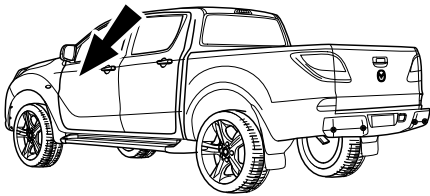

Vehicle harness to PDC module

16 OPTION 1



9

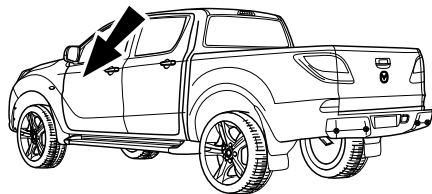

Vehicle harness to PDC module

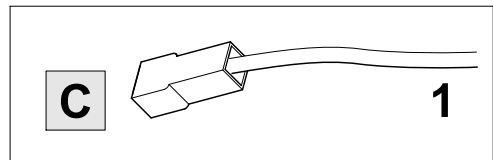
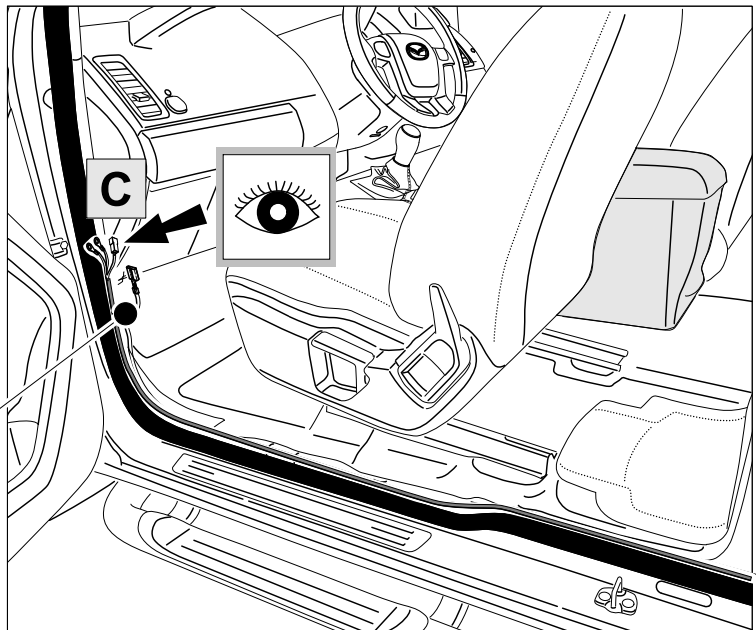
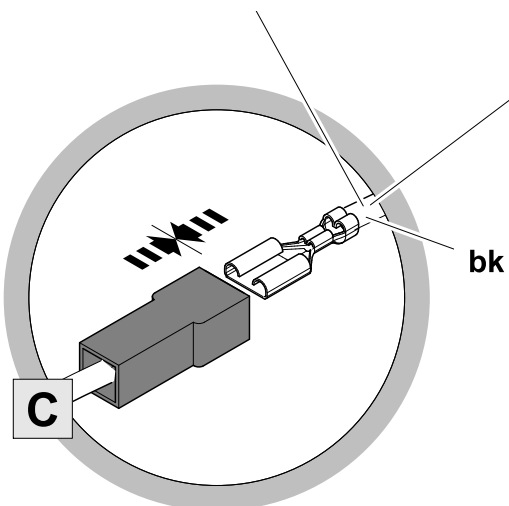

17 OPTION 1



9

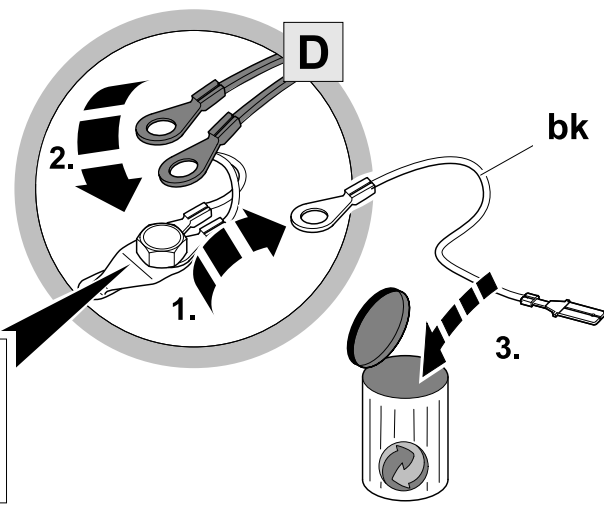
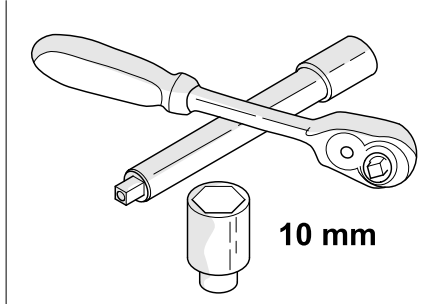
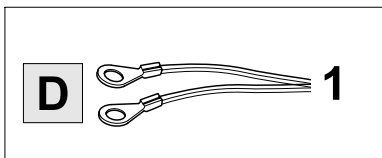
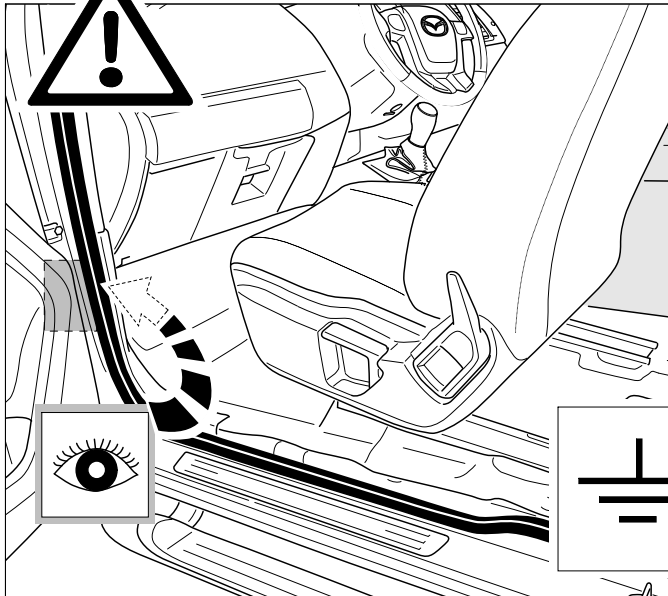
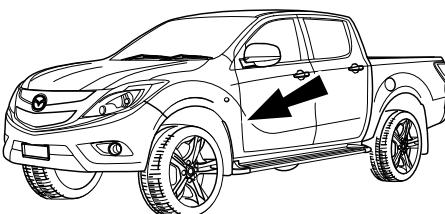

D 1

10 mm

! 

1. 2. 3. **D** bk

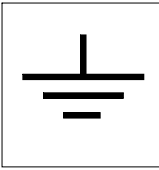

18 OPTION 2

Without PDC

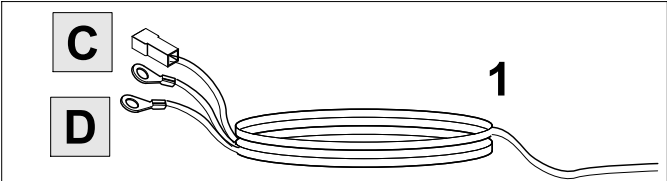
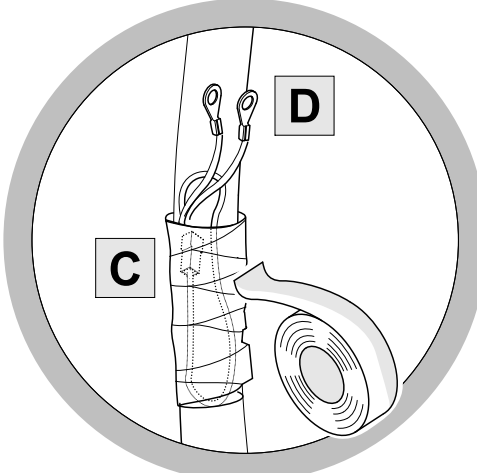
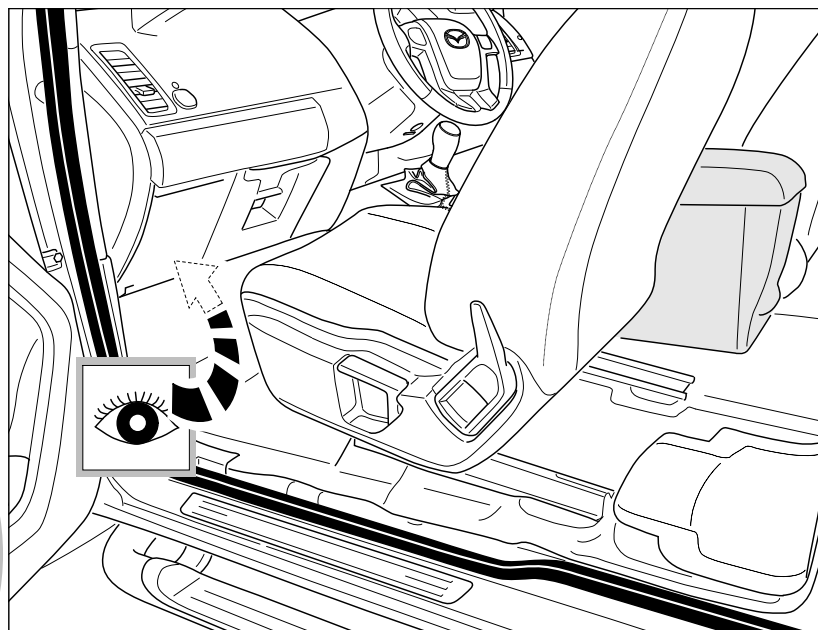
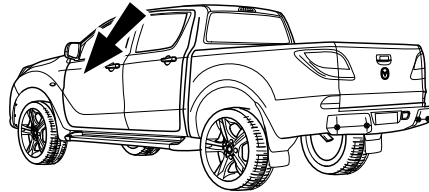

D 1

C **D** 1

19 OPTION 2

Without PDC

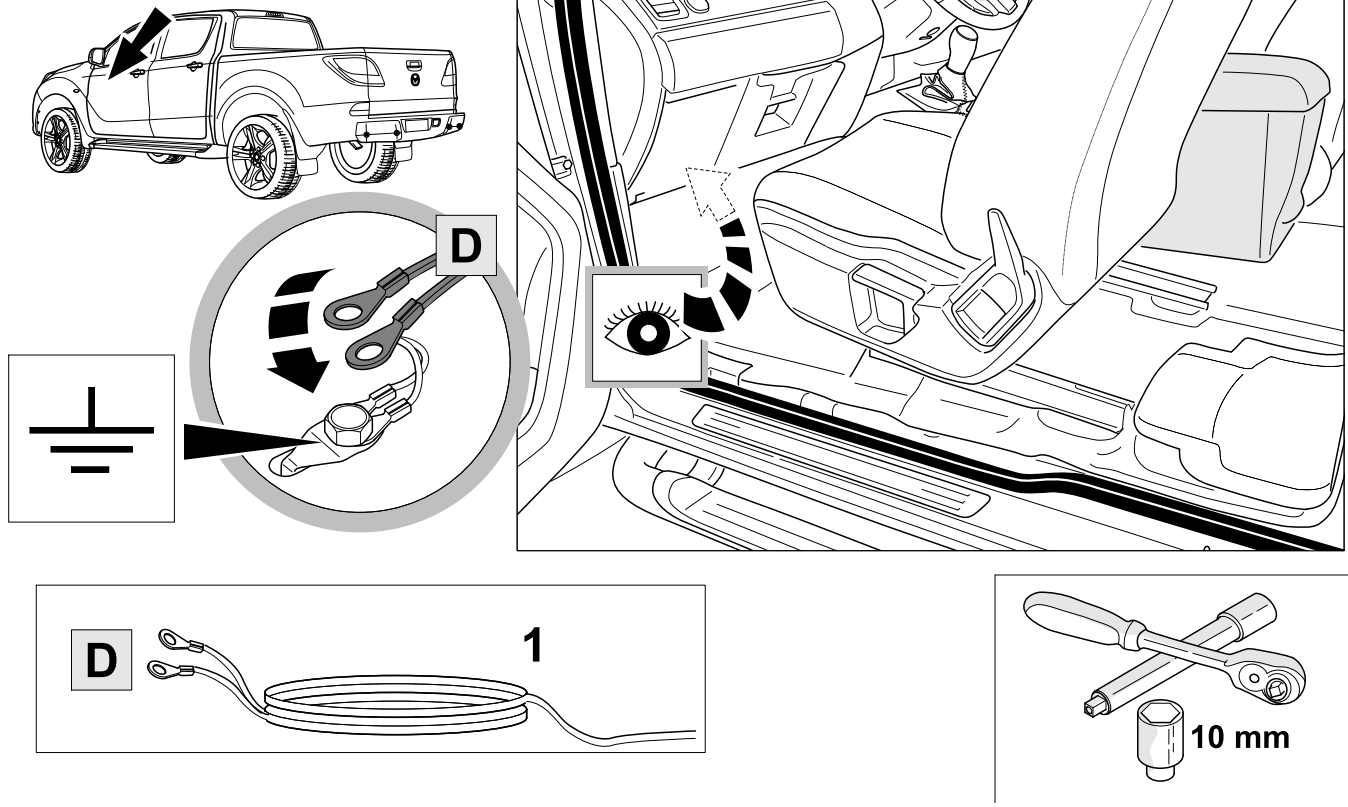

20 OPTIONAL

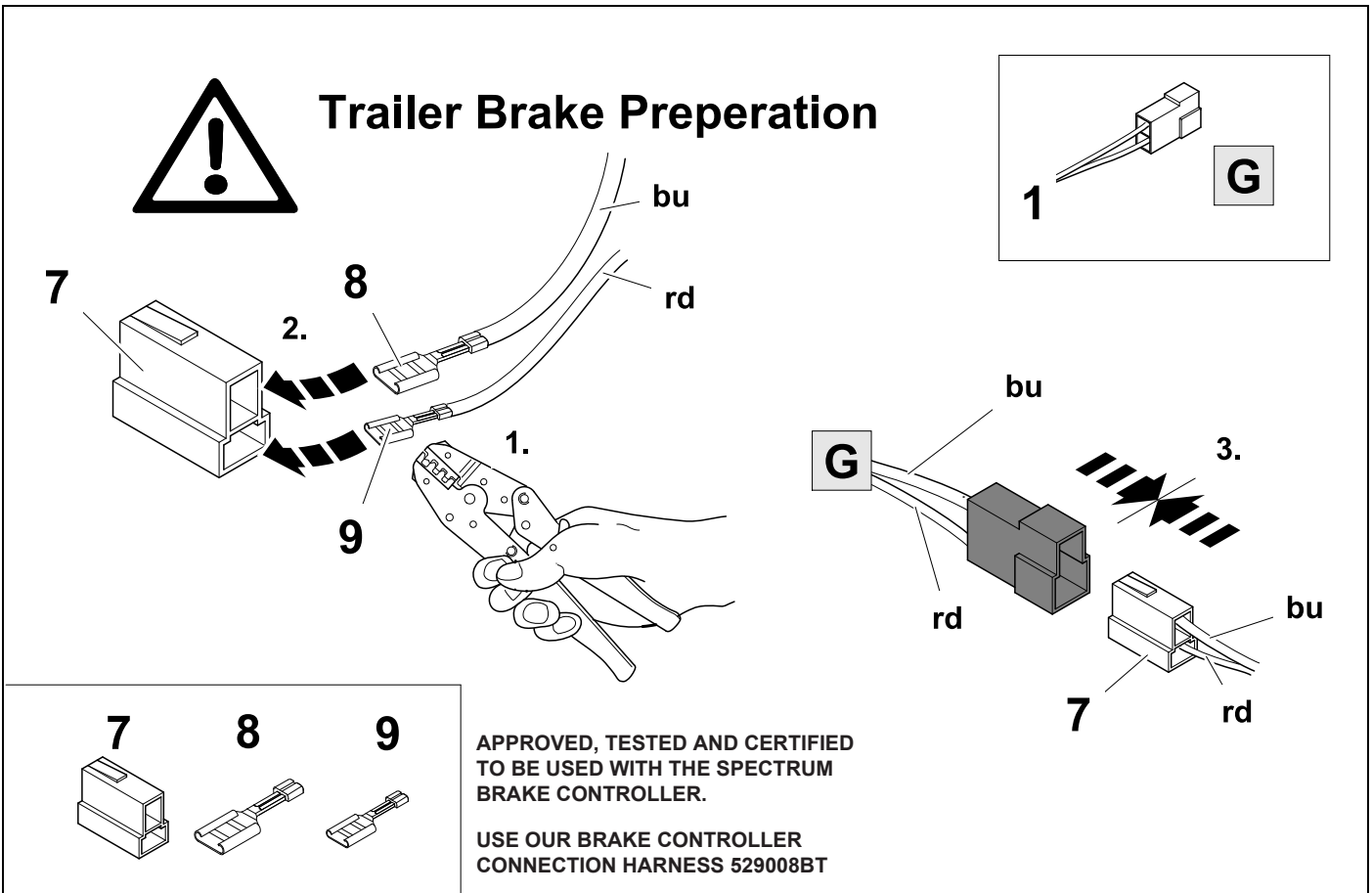

21

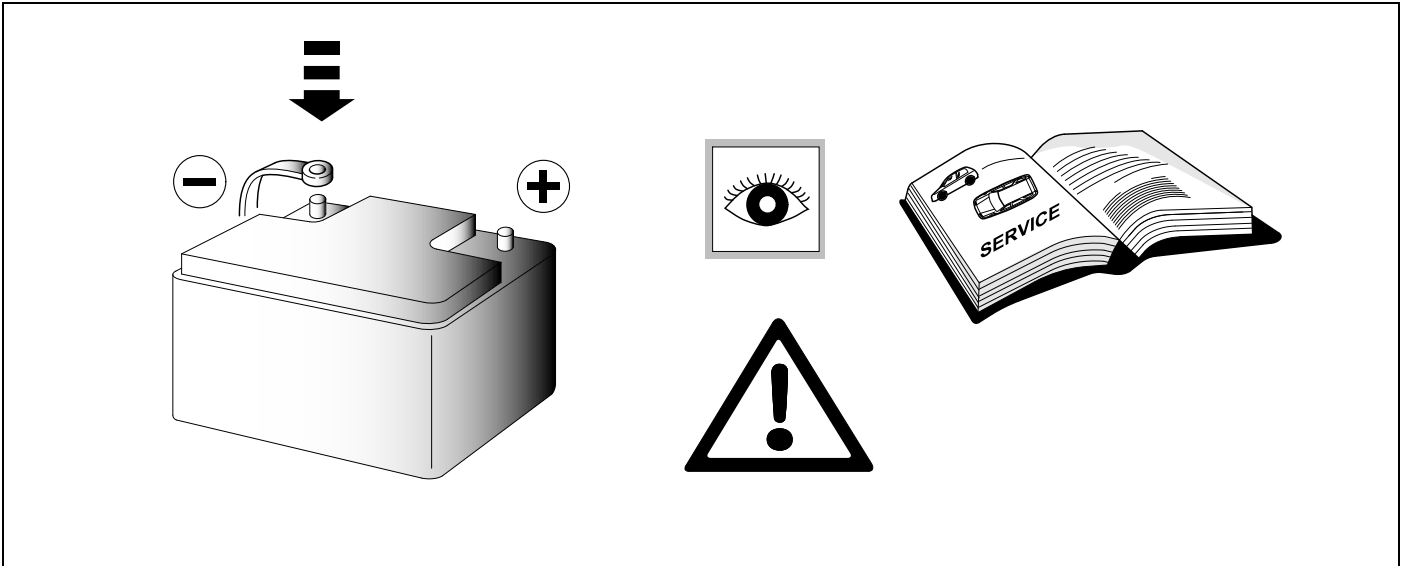

23

CHECK ALL LIGHTING FUNCTIONS

IDS



Parameter 19
 Parameter 20
 Parameter 76

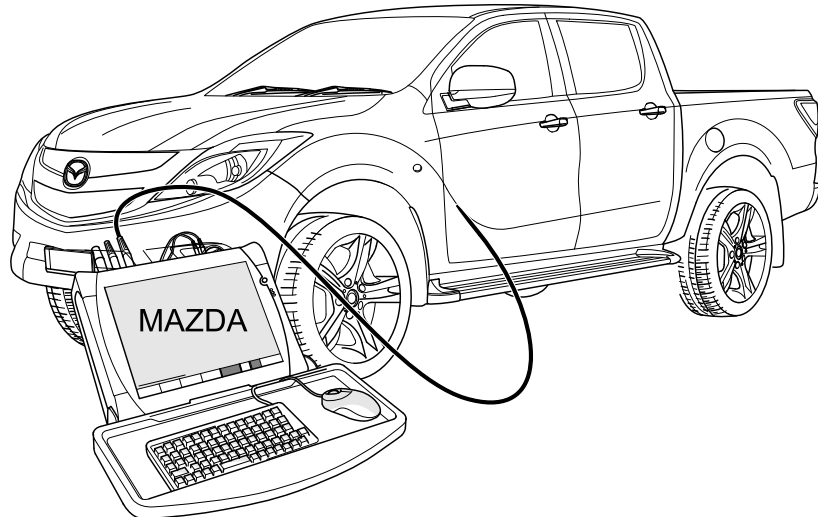

23

CHECK ALL LIGHTING FUNCTIONS

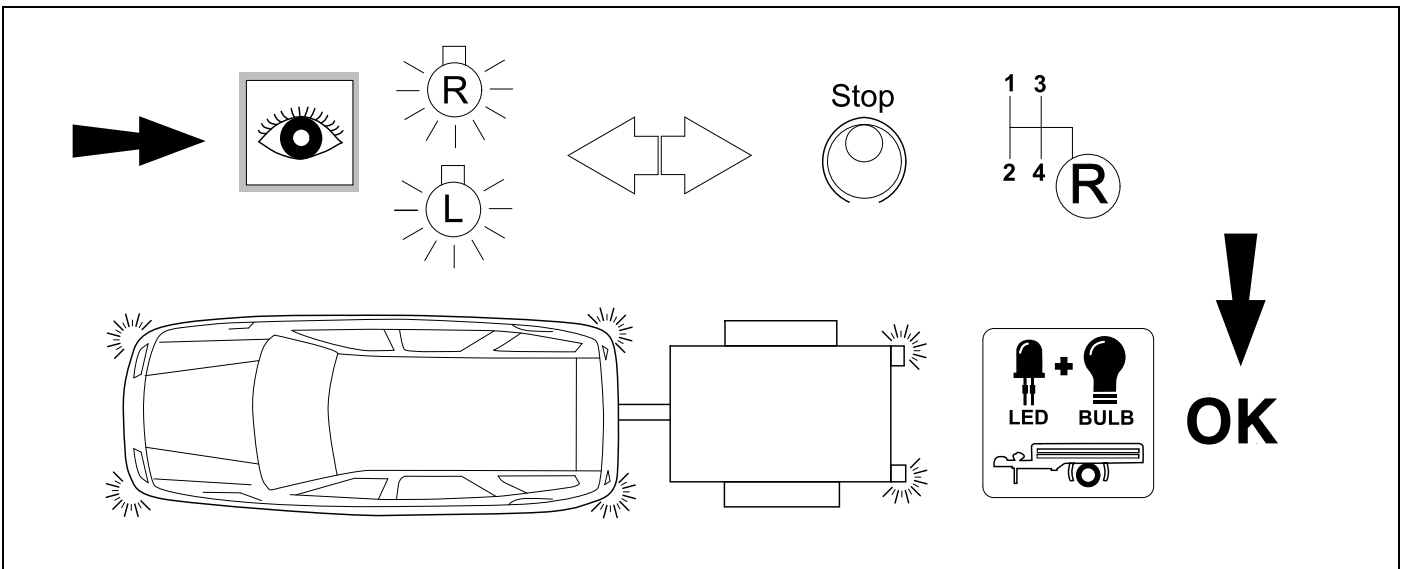

24

CHECK BULB OUT DETECTION

BULB OUT CONDITION INDICATED WITH INCREASED INDICATOR FREQUENCY

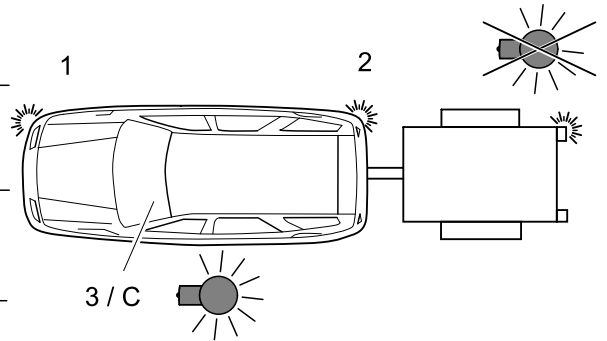
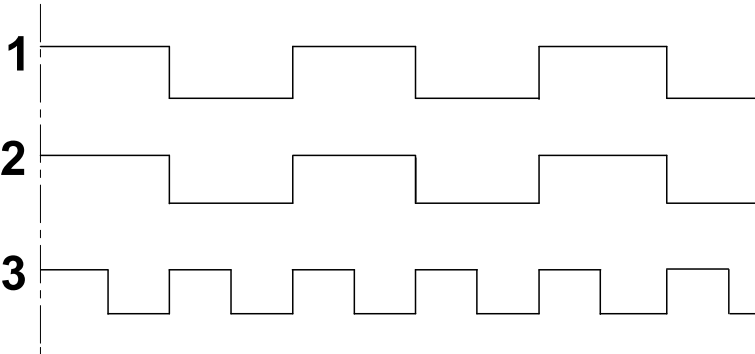

25



14

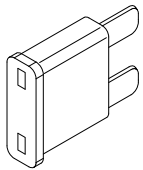

20 A

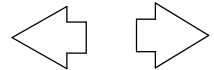
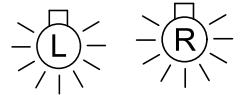
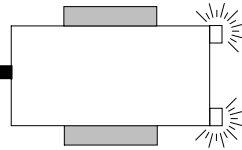

Stop

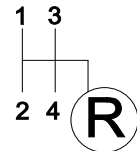
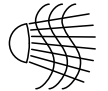

26

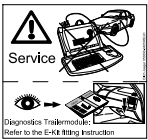

2x 6

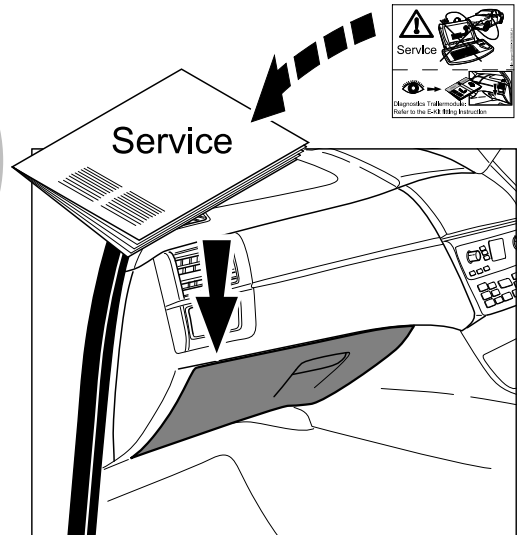

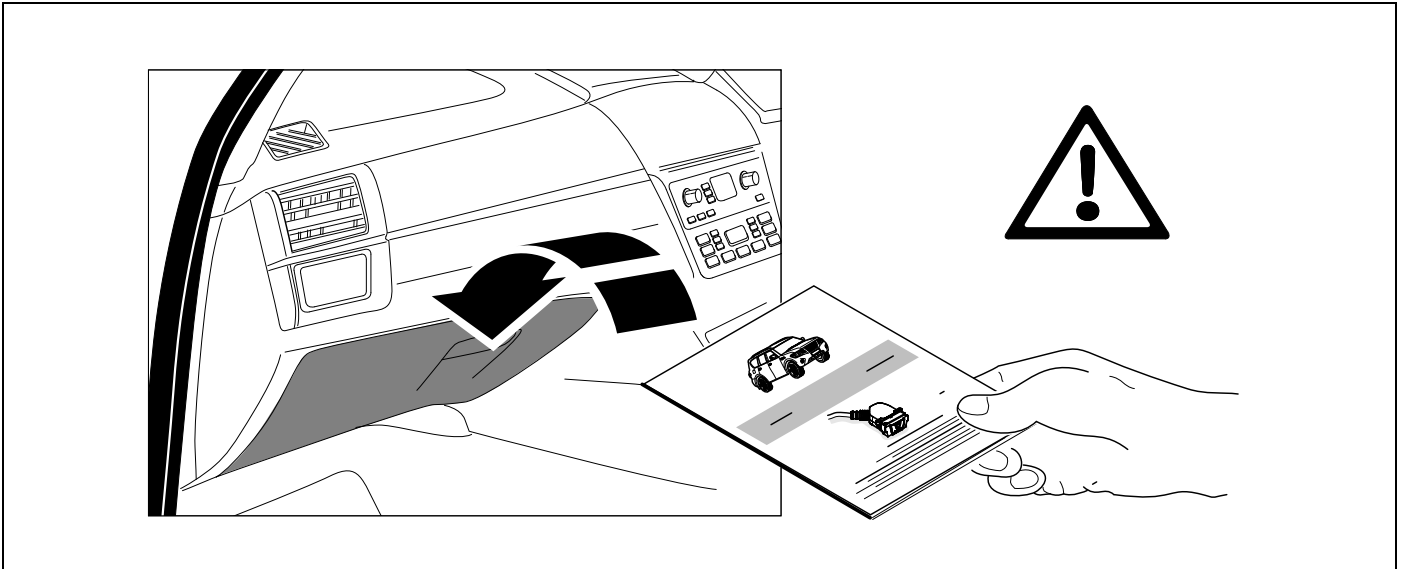

Subject to change in terms of construction, equipment and colour, and may contain errors.
The information and illustrations are non-binding.

Status LED for self-diagnosis

Operation Support

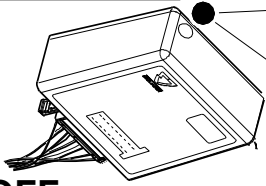
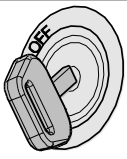

No CAN-Data =



Standby / Sleepmode



Ignition OFF

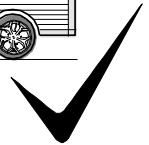
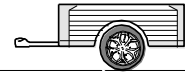
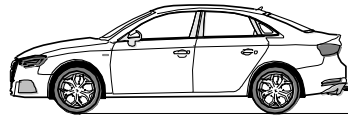
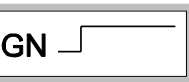
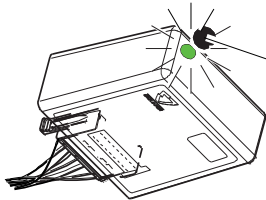

Ignition ON

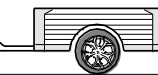
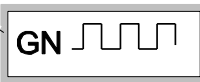
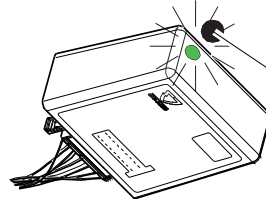

Ignition ON

Failure Support

CAN-Data Wire



1x max. 5 min.

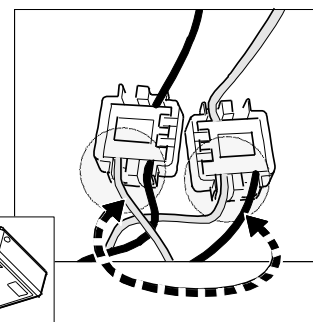
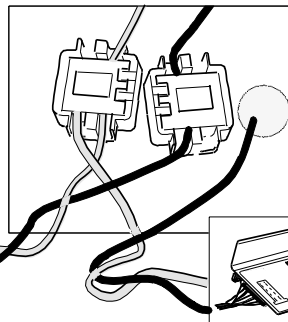
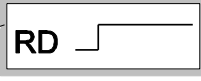
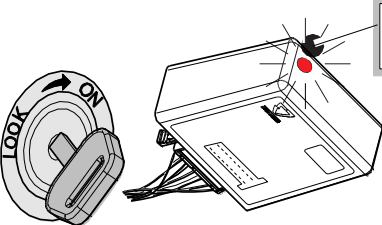

Ignition ON

Failure indicated by the module LED glowing red for a maximum of 5 minutes. If trailer connected the tail lights will also glow indicating failure of CAN signal.

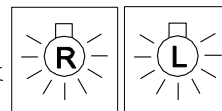

Ignition ON

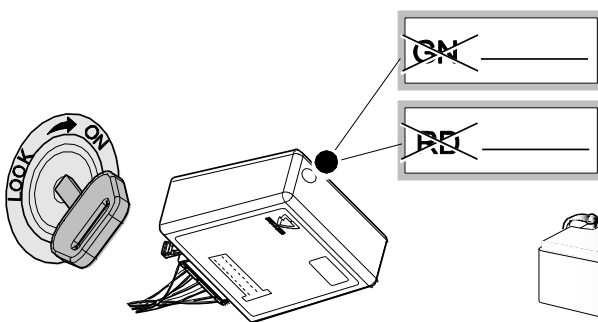

or

