

MAZDA 6 GL Wagon

04/18 >>

Part No. 750096

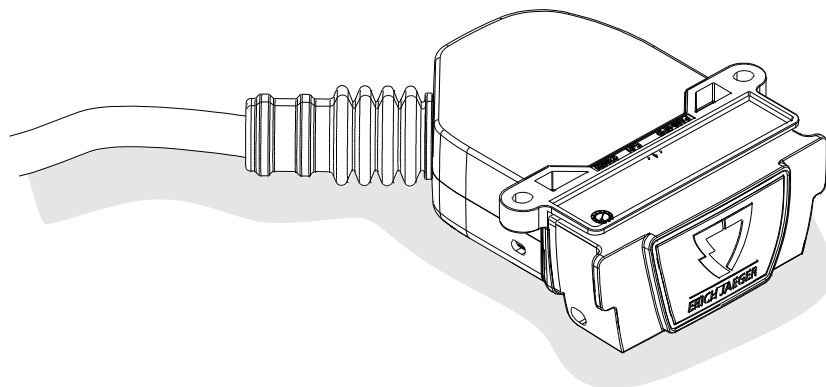

Installation instructions

Reference:

The following information must be reviewed before beginning the assembly:



The installation instructions are to be thoroughly read.
The installation should be carried out by qualified personnel with the relevant technical knowledge.
The vehicle manufacturers' current technical notices and information on retrofitting must be followed.
The removal and replacement instructions found in the current repair manuals must be followed.
It must be ensured that the vehicle is technically suitable for the installation of a trailer hitch.

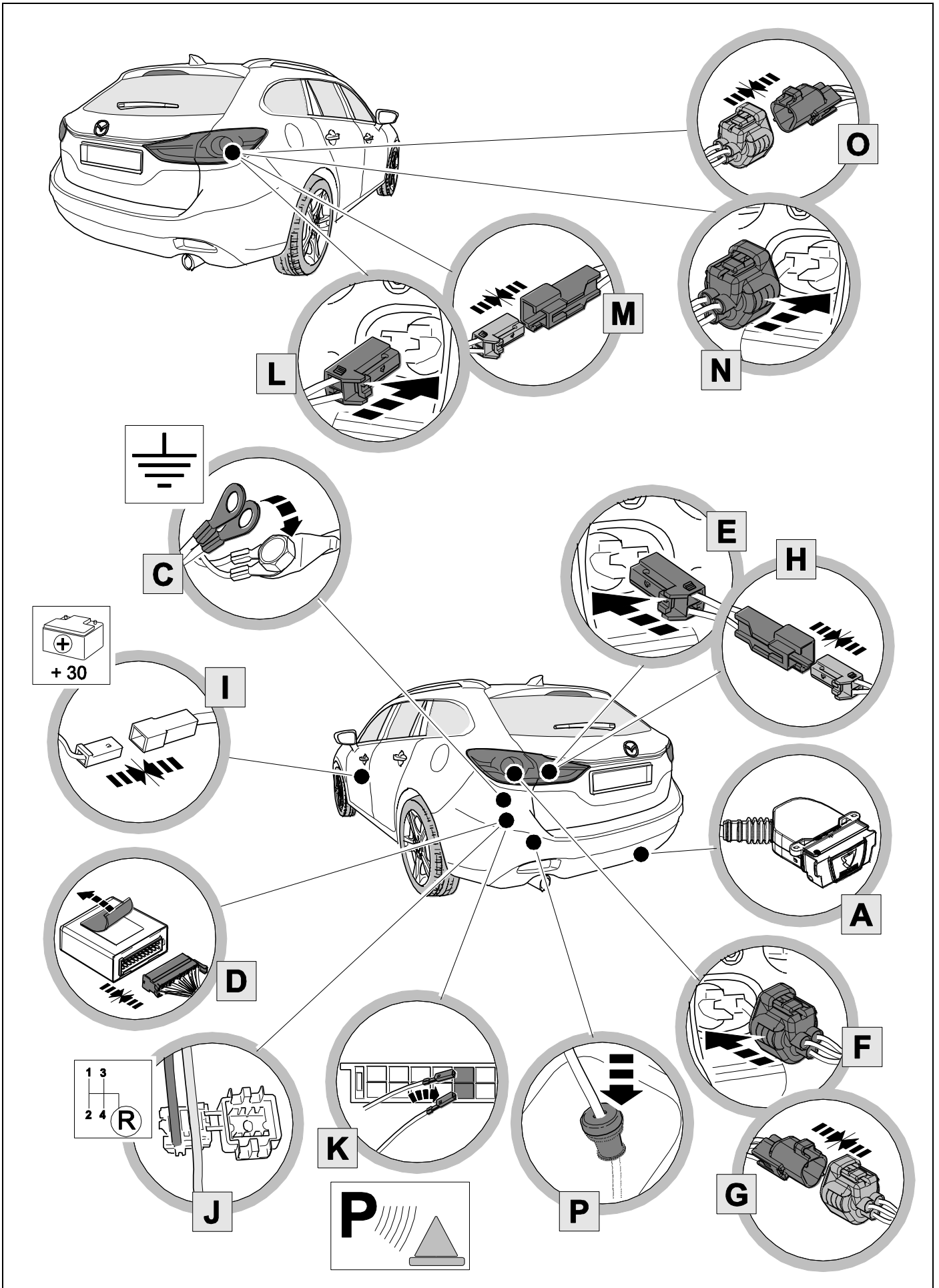

KIT

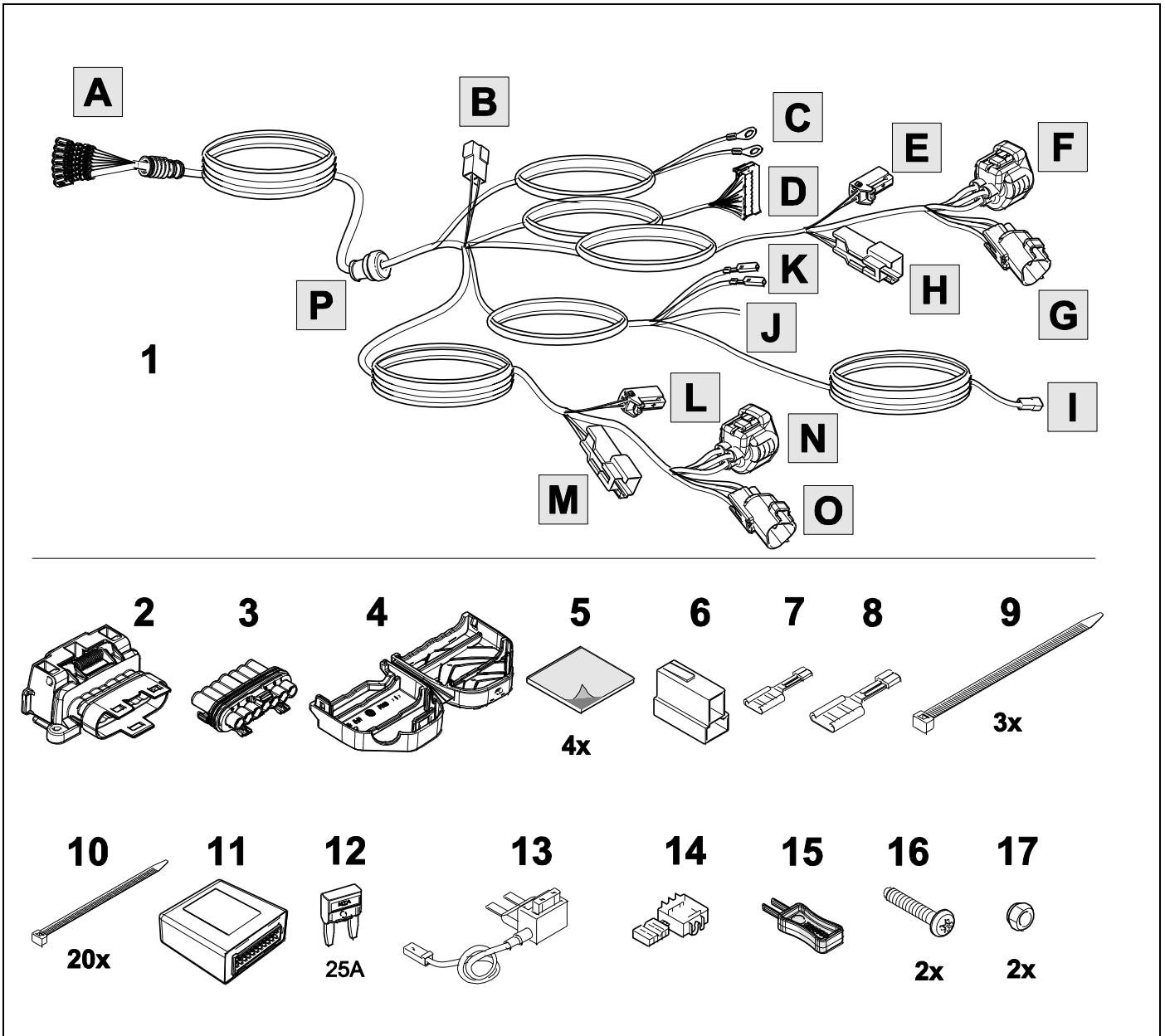

TOOLS

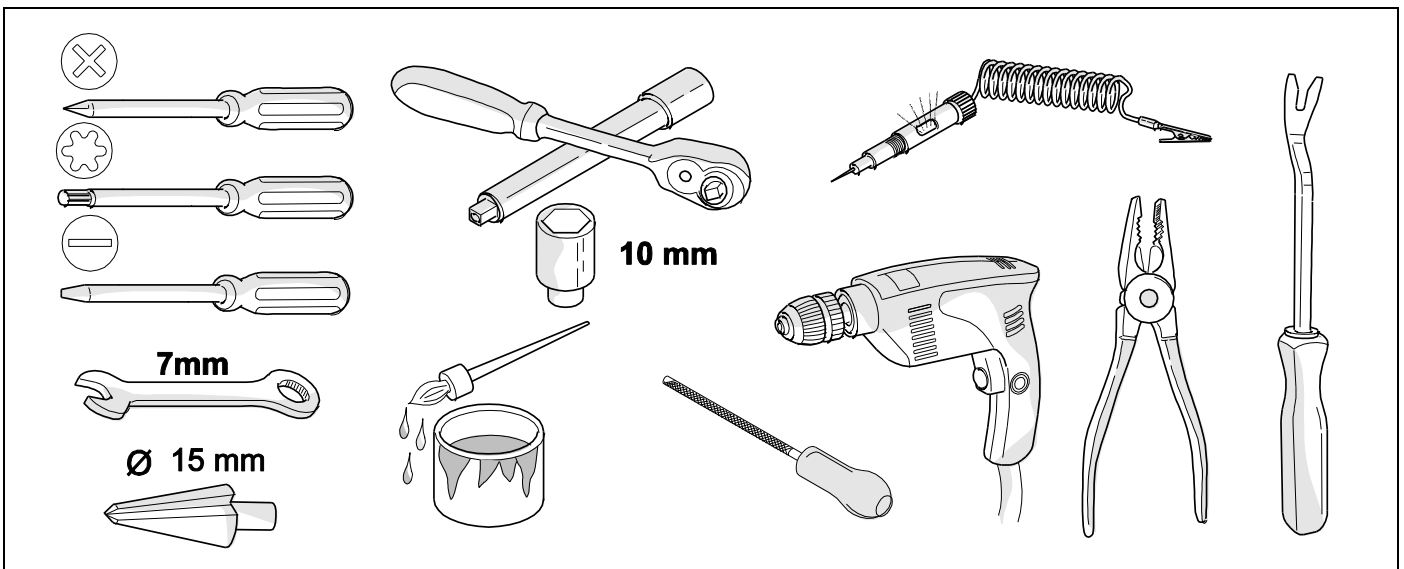

1

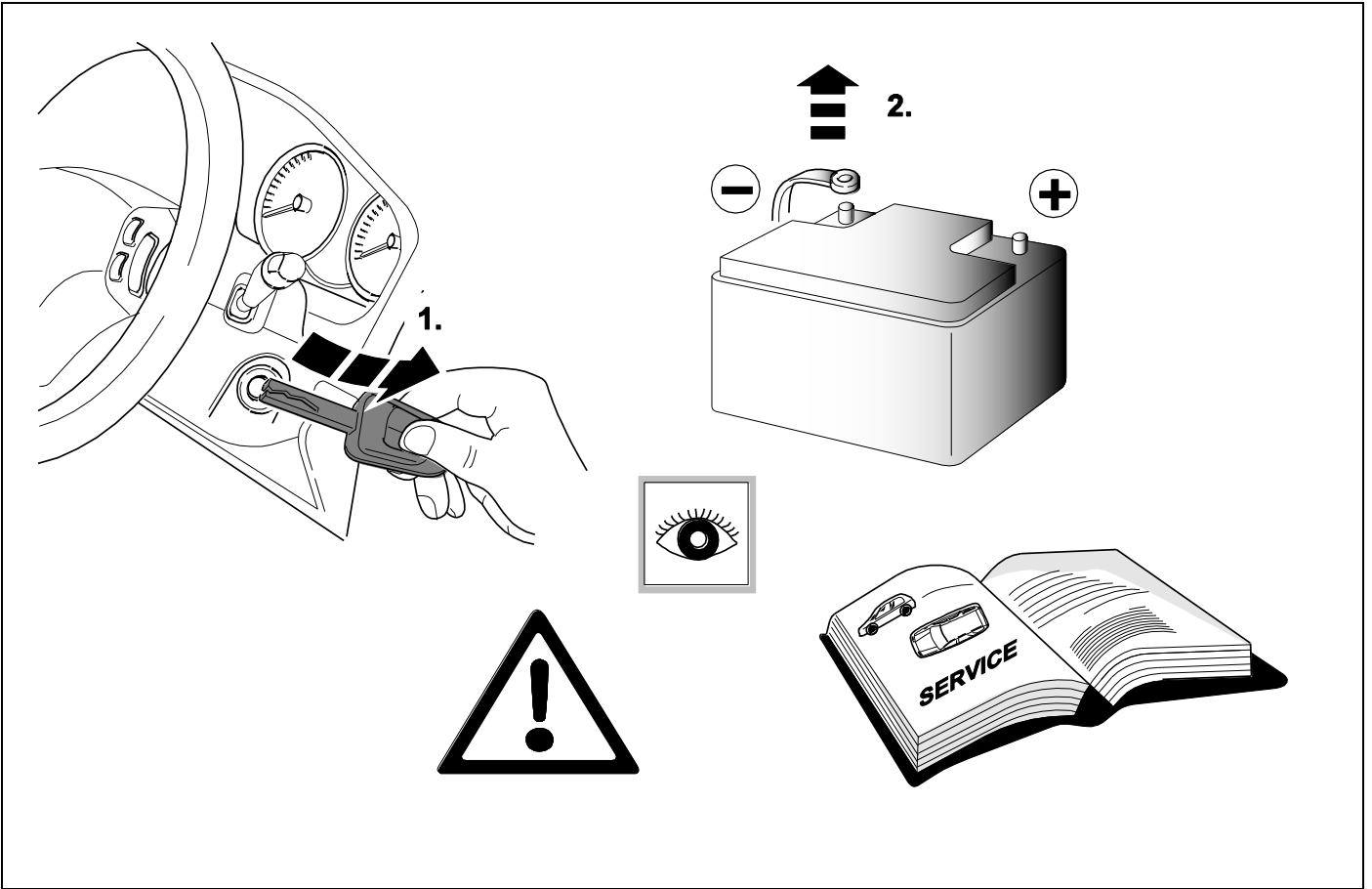

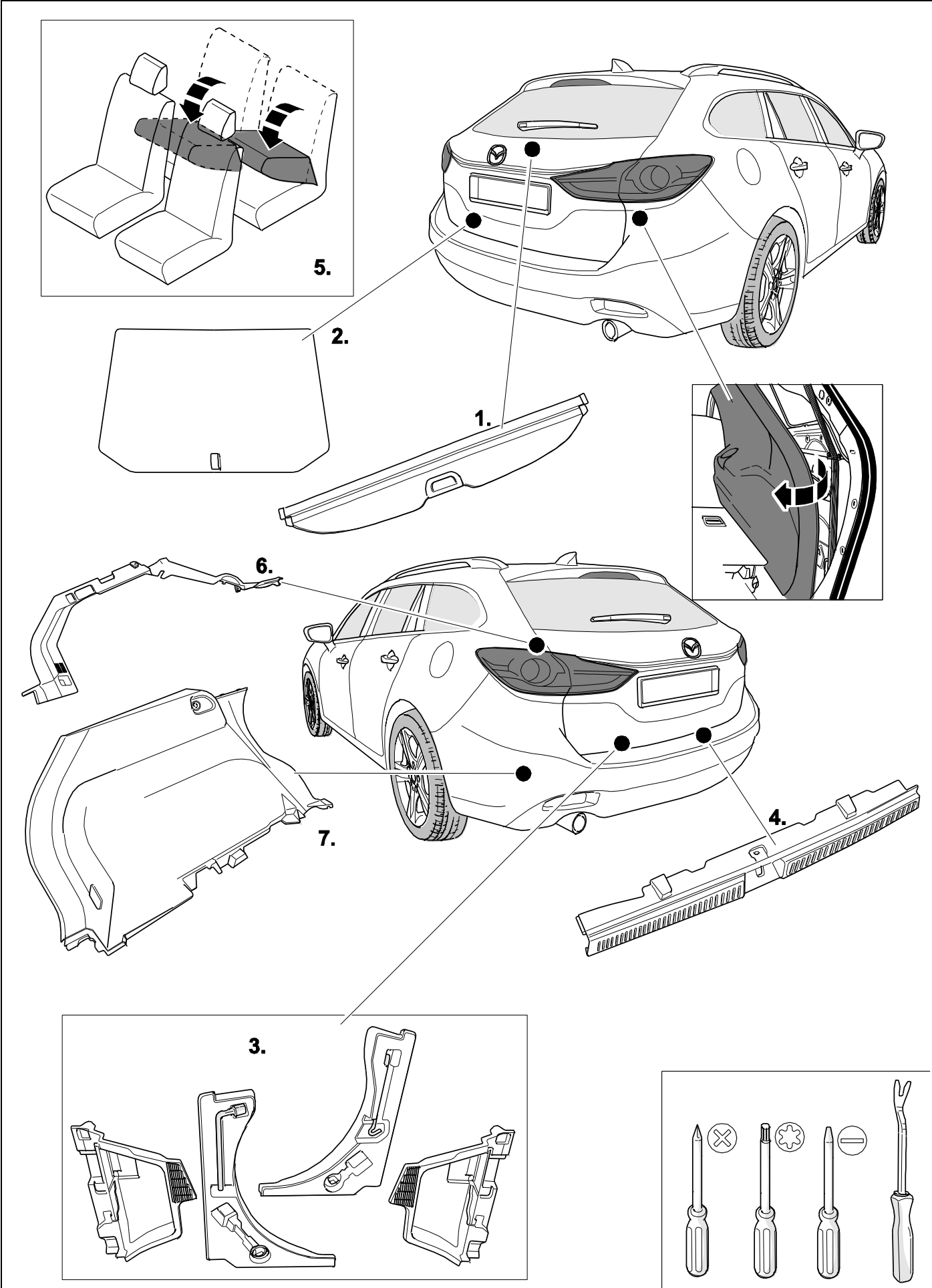

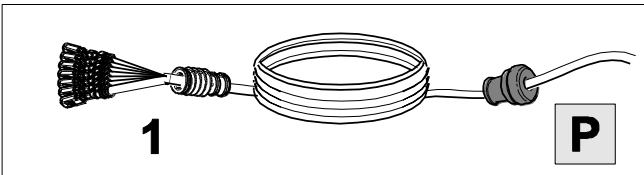
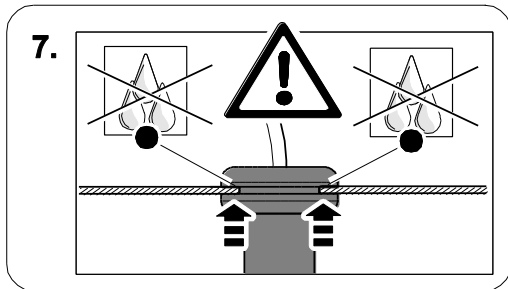
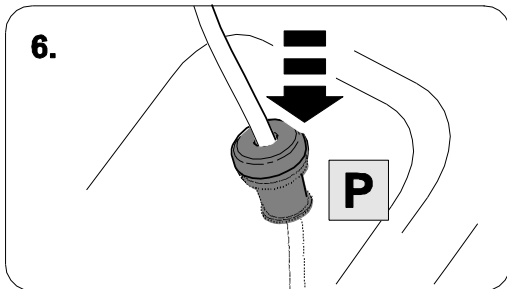
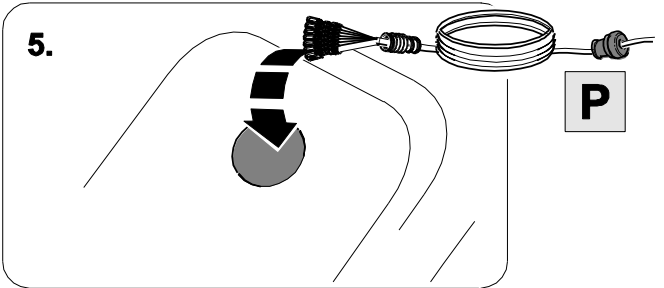
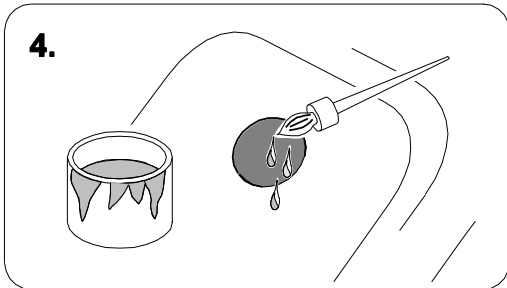
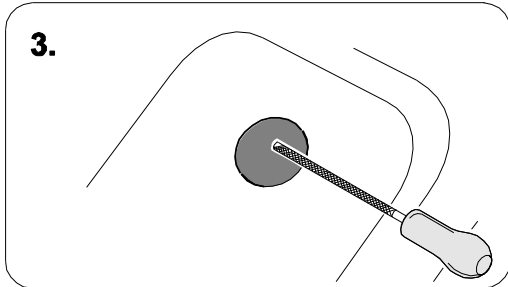
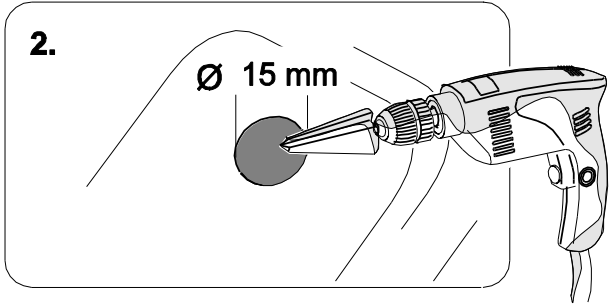
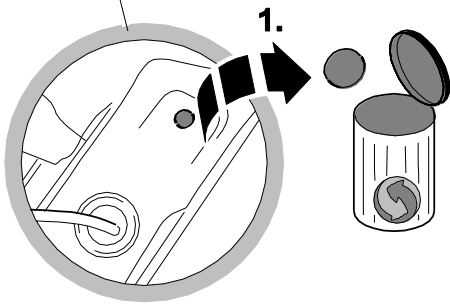
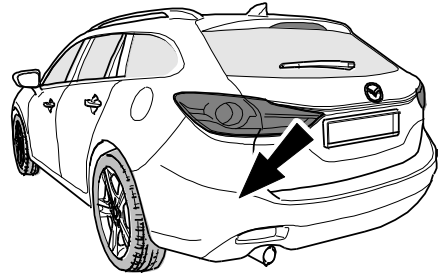
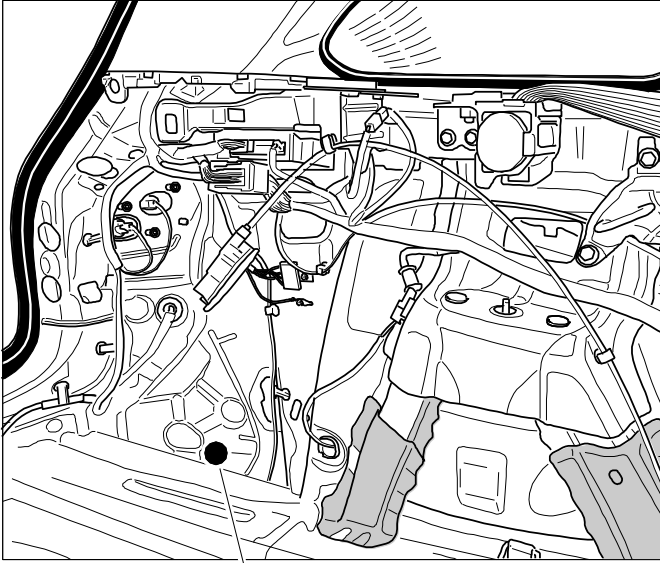

4

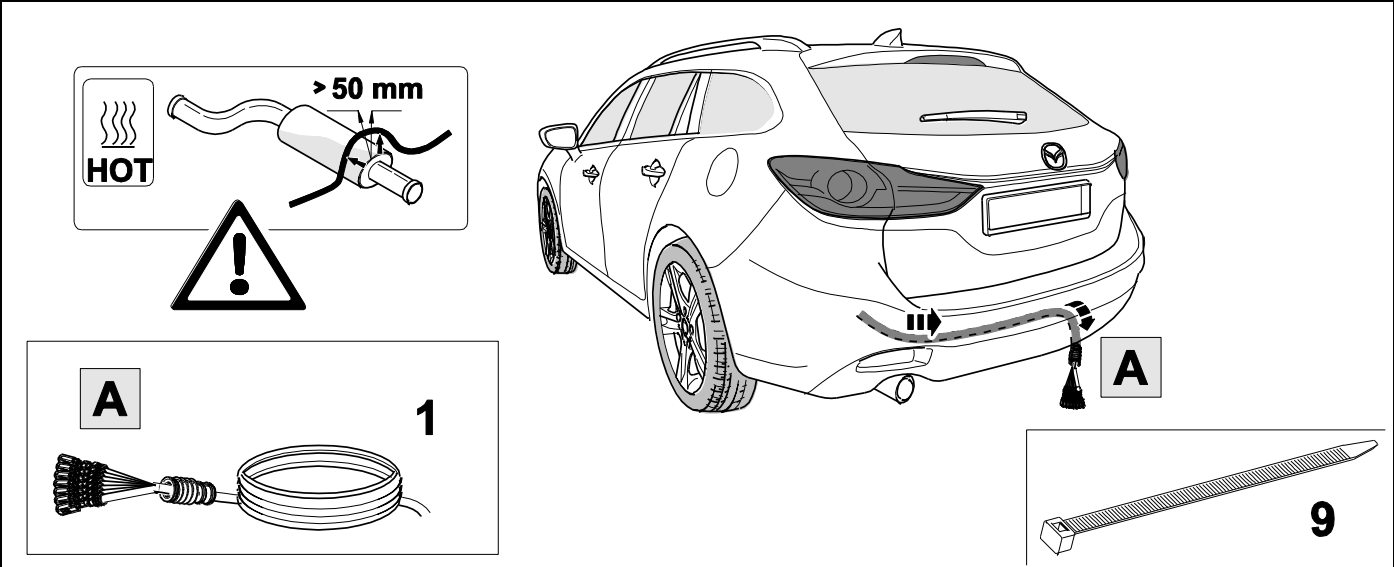

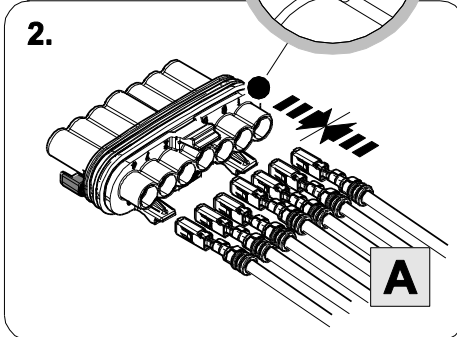
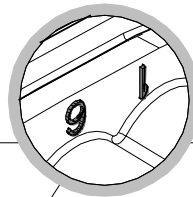
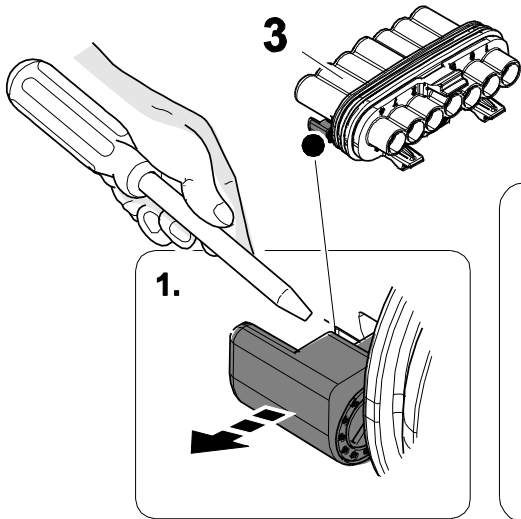

ye	1	
rd	6	
bu	5	
wh	3	
bk	2	
bn	7	
gn	4	

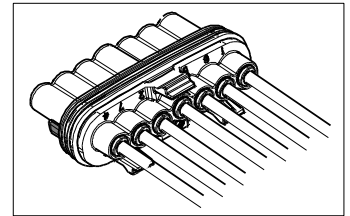
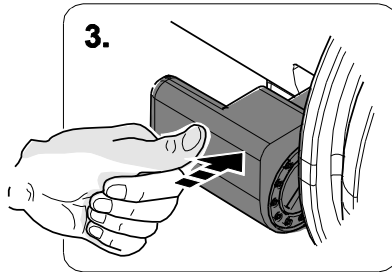
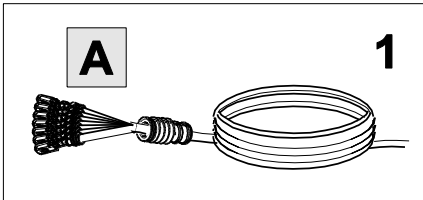

In case of wrong pin insert:

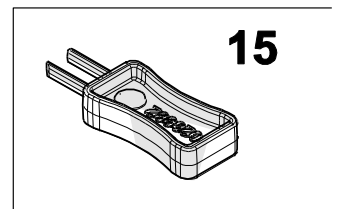
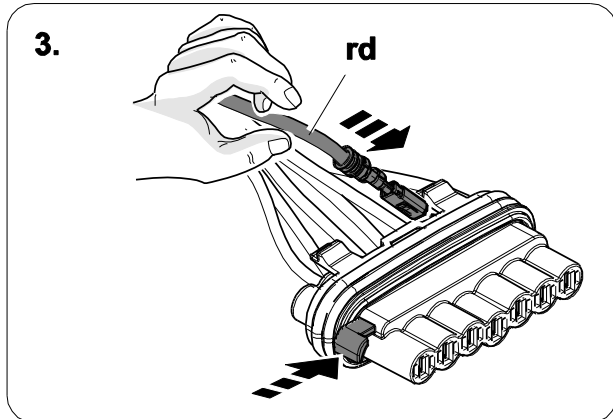
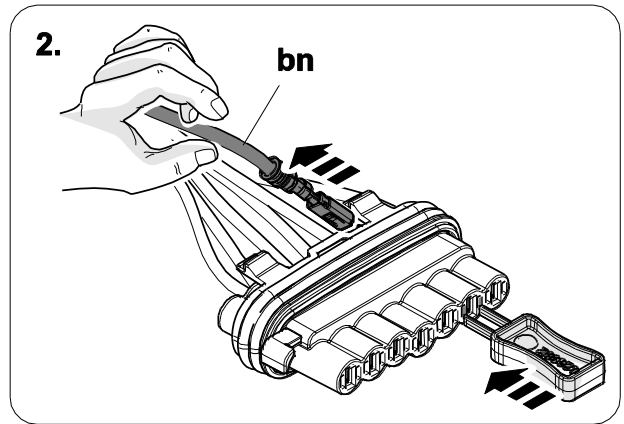
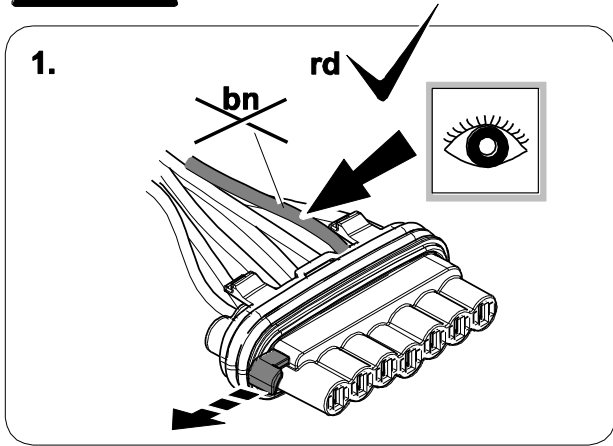

6

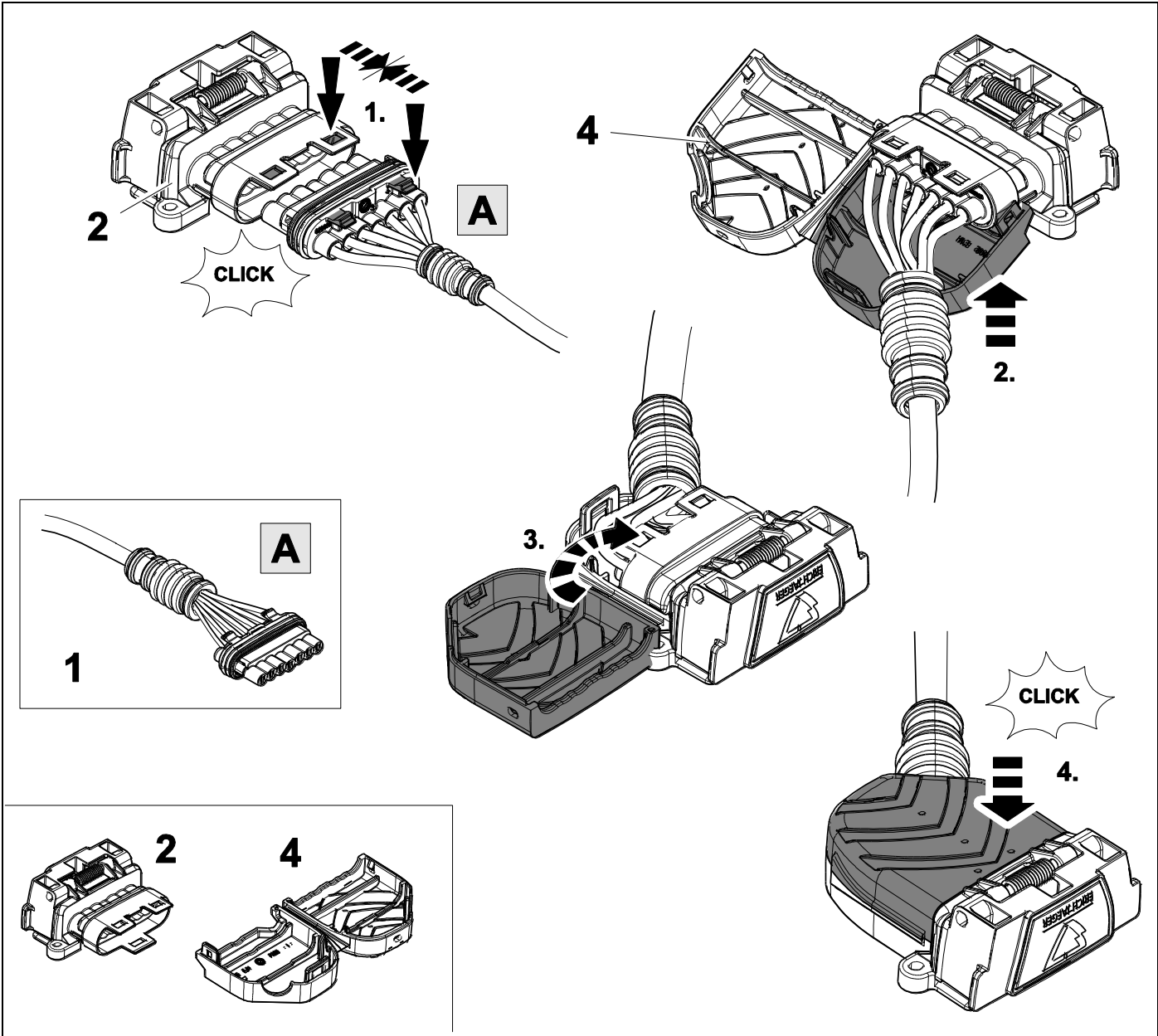

7

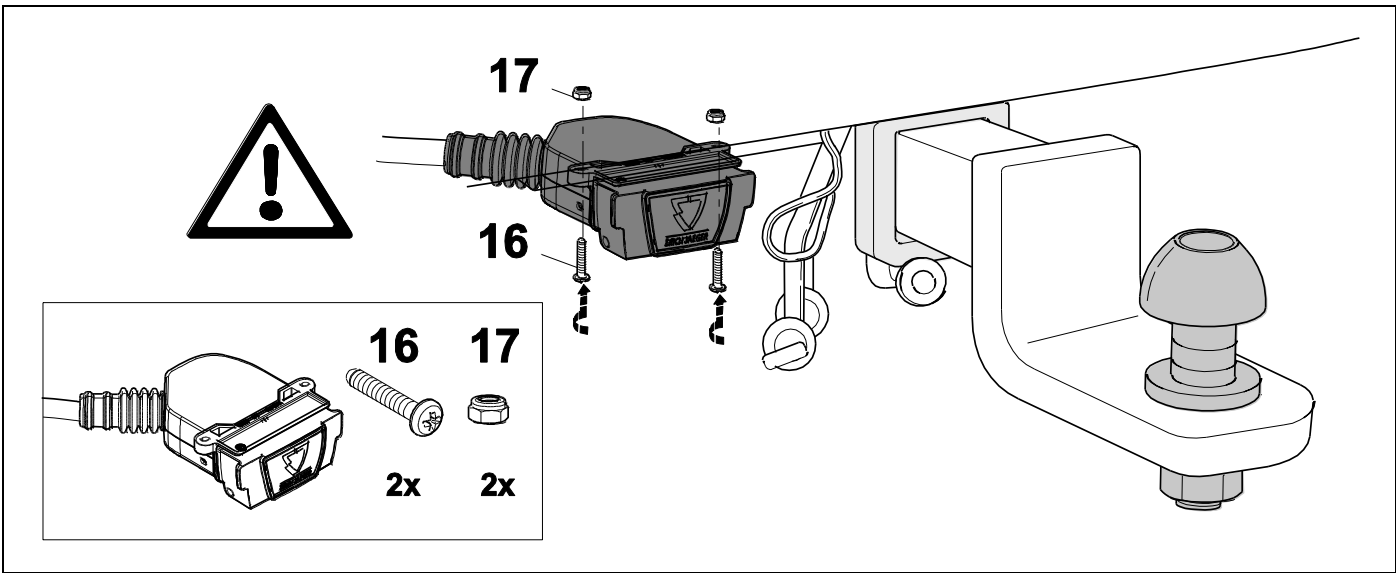

8**9**

1	ye	
2	bk	
3	wh	
4	gn	
5	bu	
6	rd	
7	bn	

9	bk	wh	gy	gn	rd	bu	ye	bn	pu	or	no
----------	-----------	-----------	-----------	-----------	-----------	-----------	-----------	-----------	-----------	-----------	-----------

	black	white	grey	green	red	blue	yellow	brown	purple	orange	not occupied
--	-------	-------	------	-------	-----	------	--------	-------	--------	--------	--------------

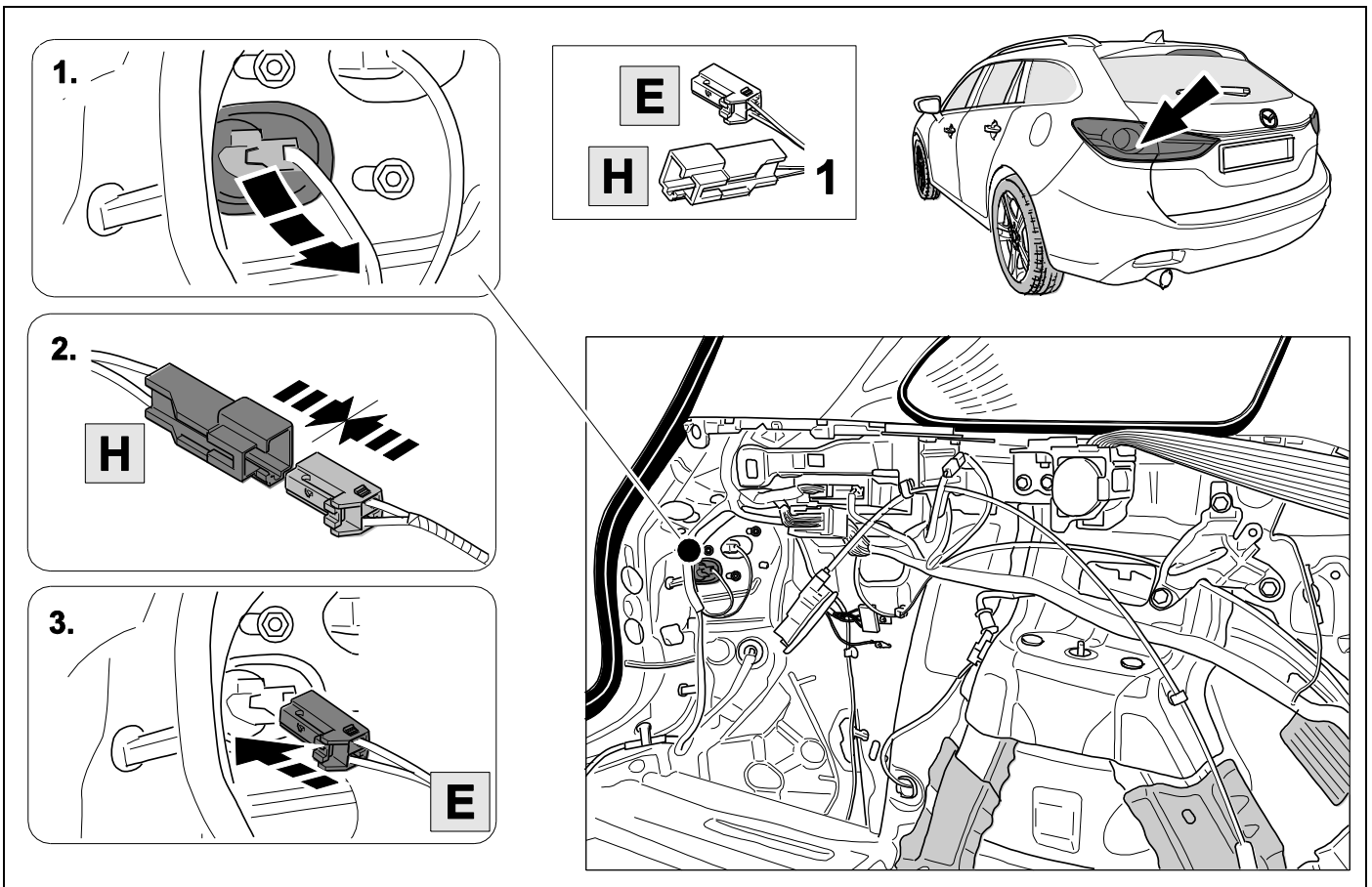
10

11

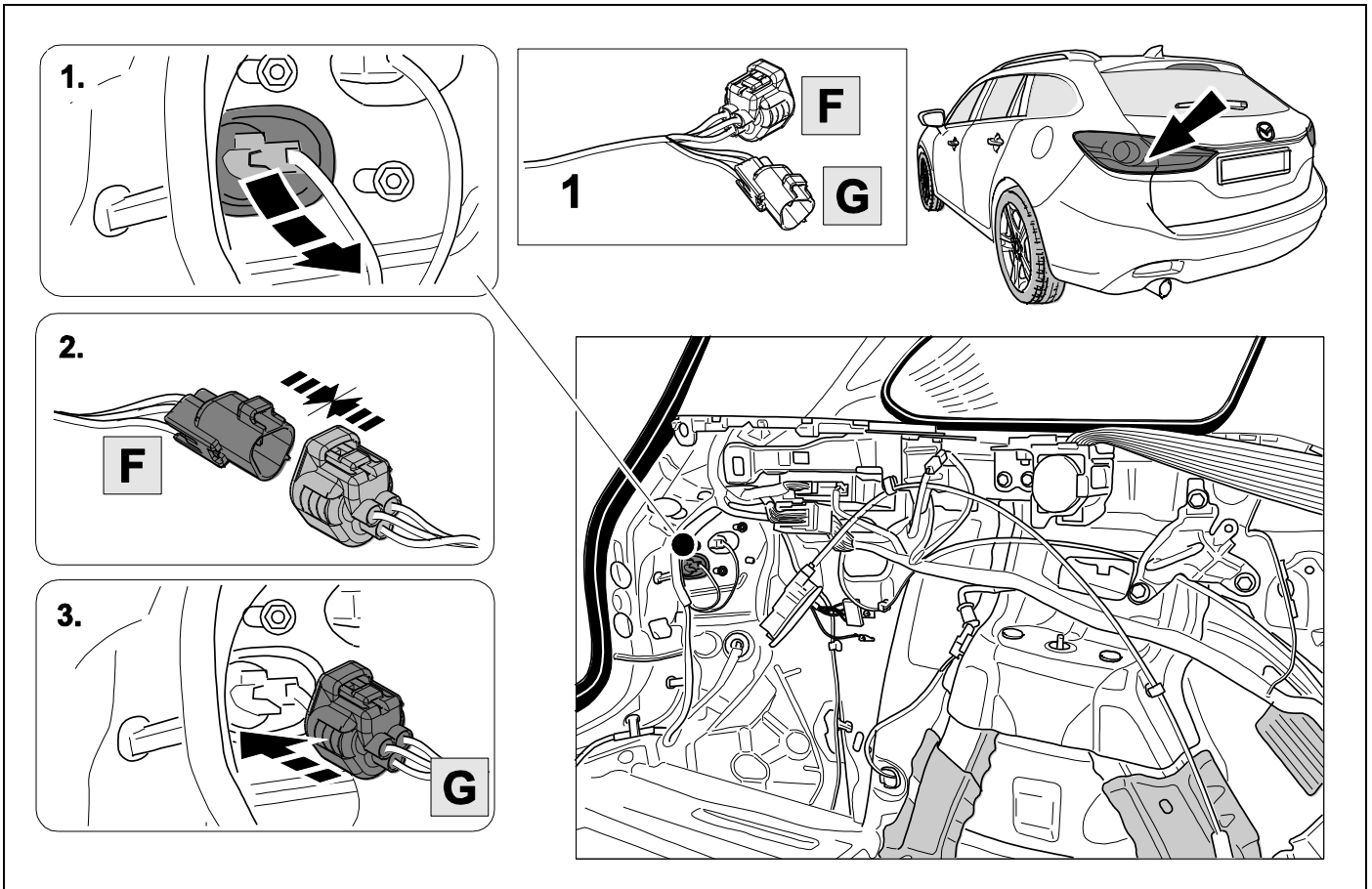

12

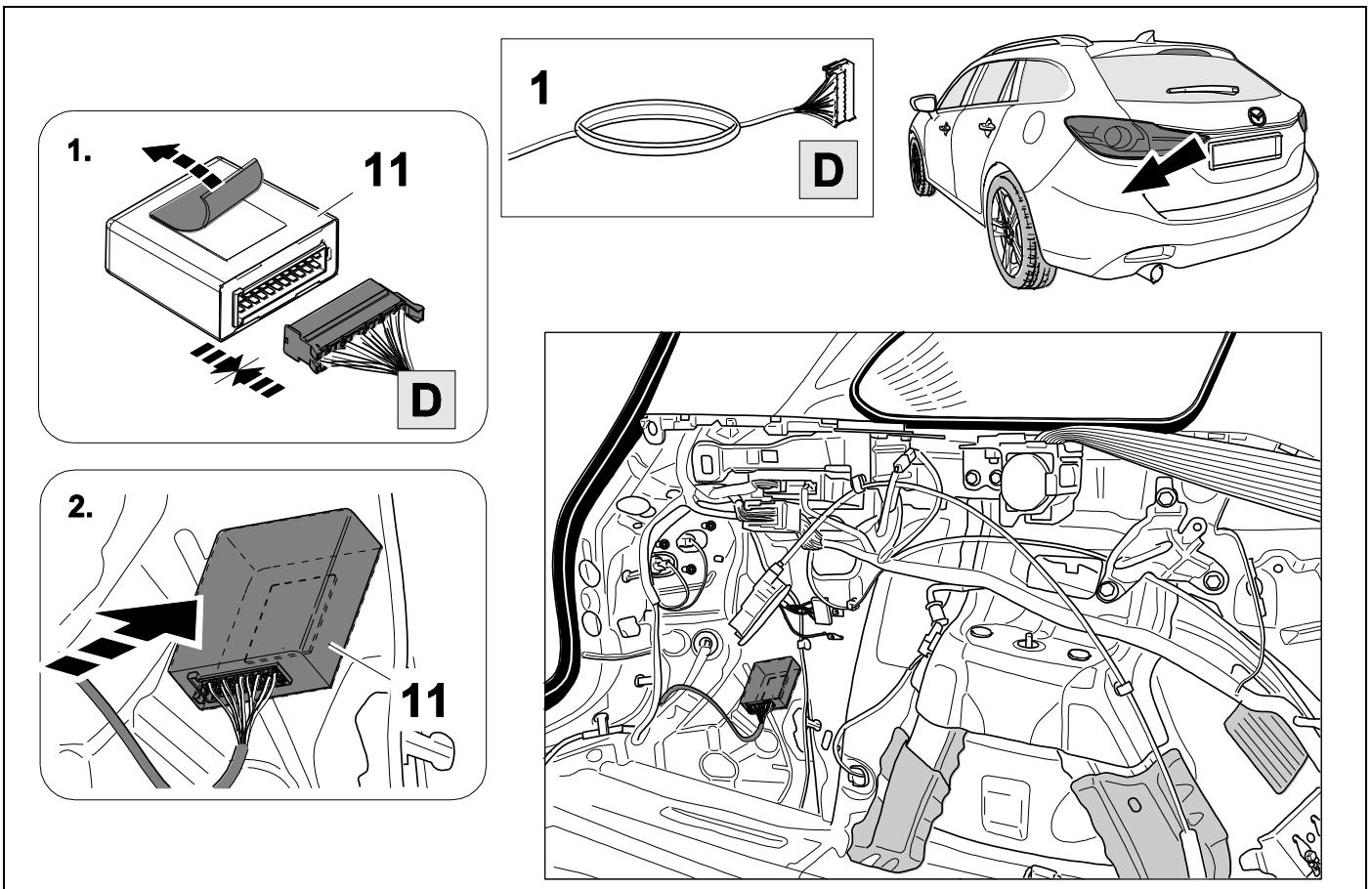

13

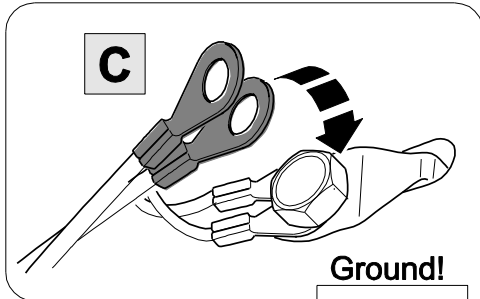
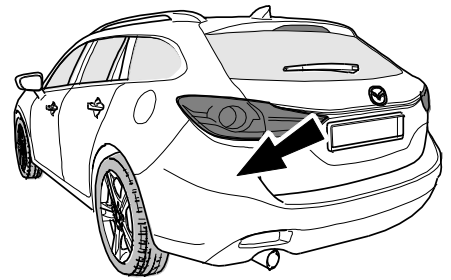
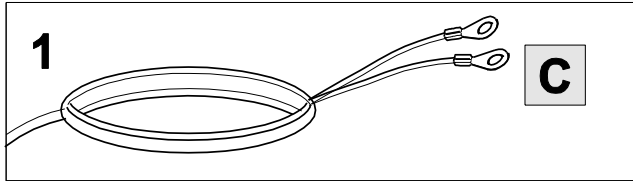

Ground!

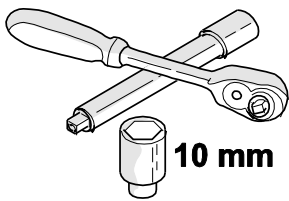
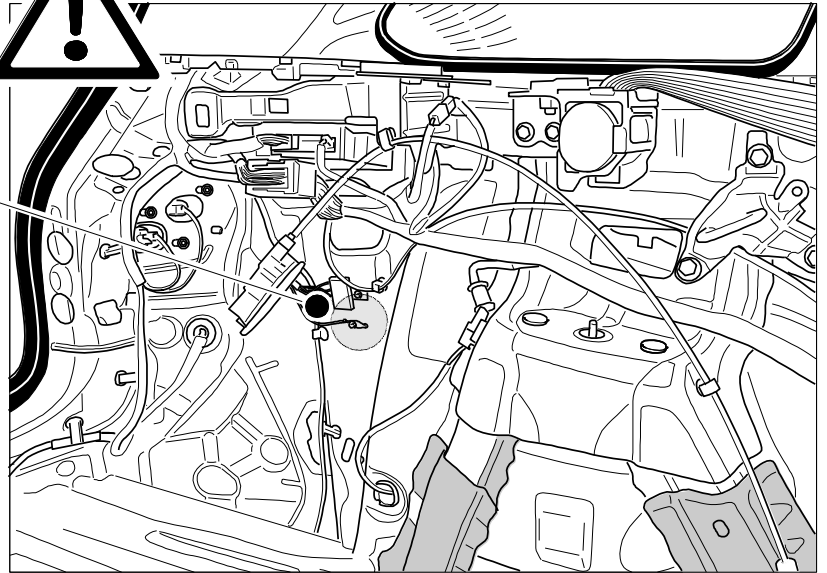
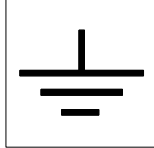

14



9

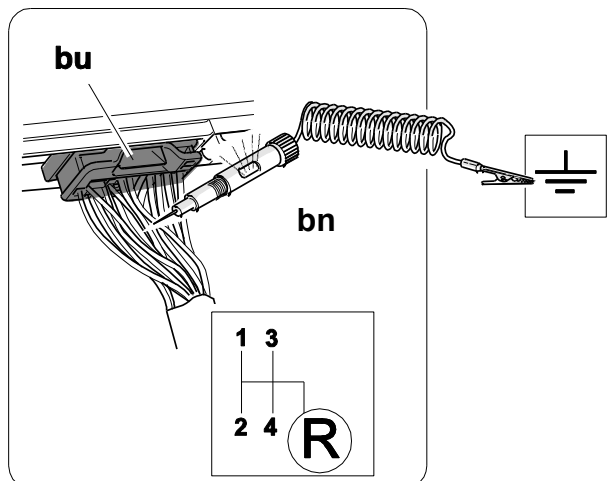
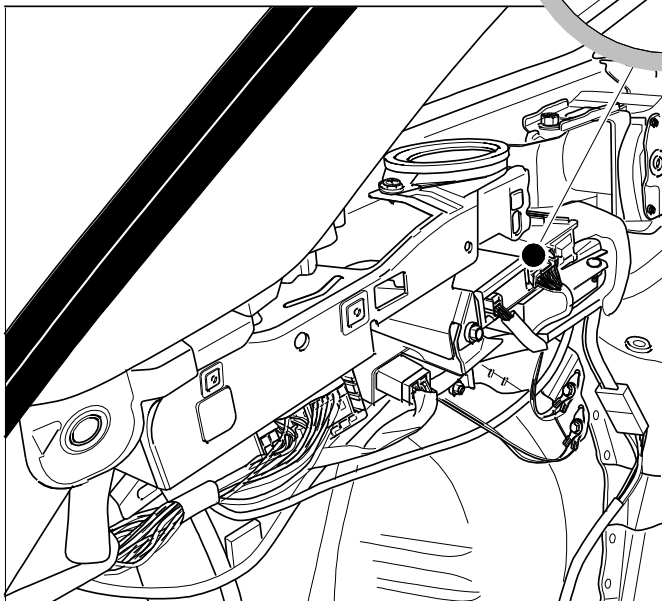
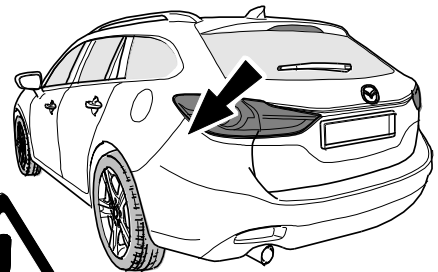
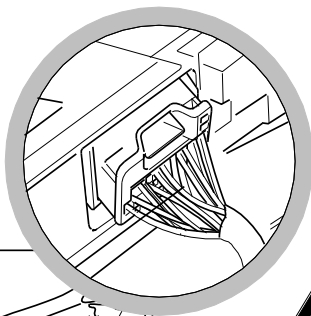

15

⇒ 9

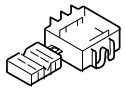
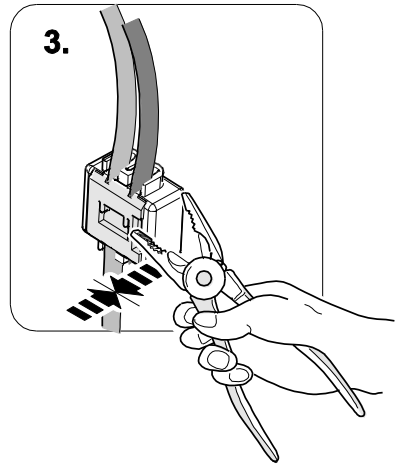
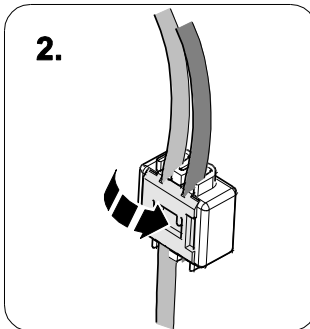
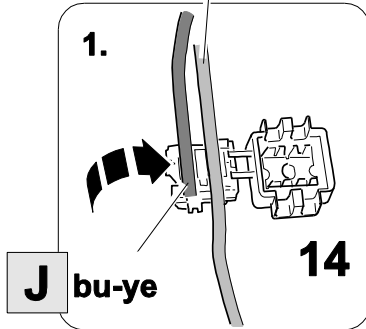
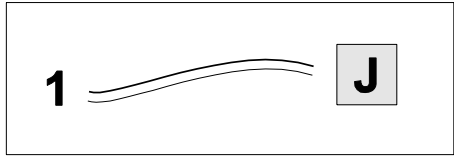
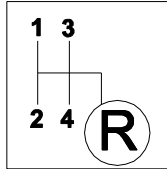
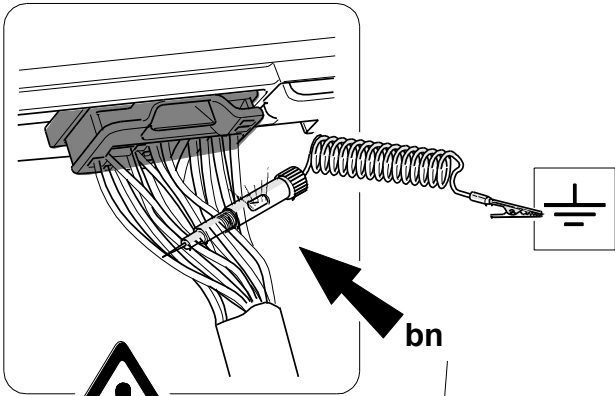

14

16

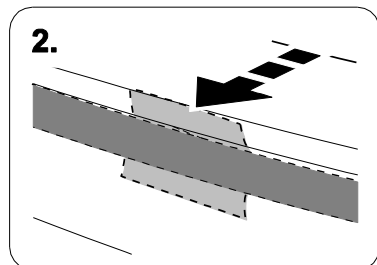
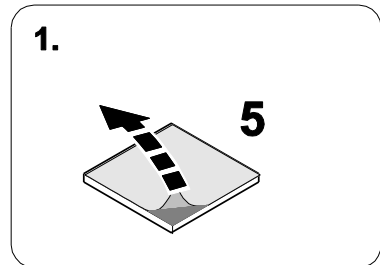
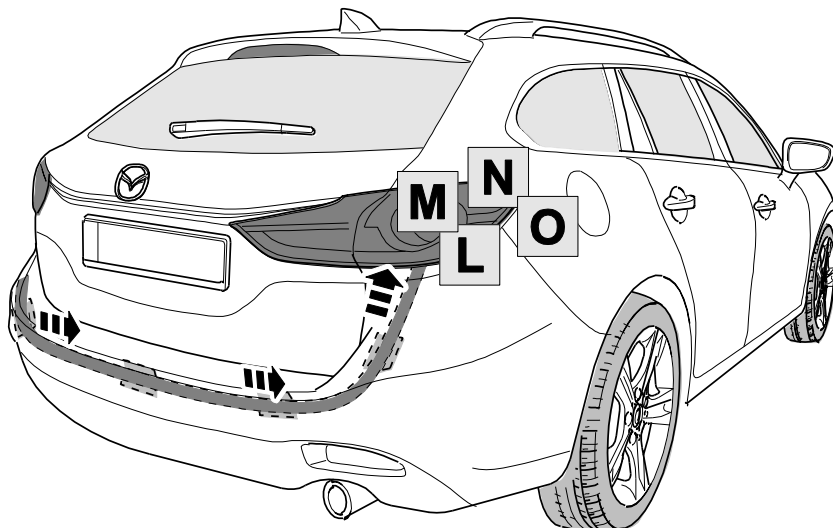
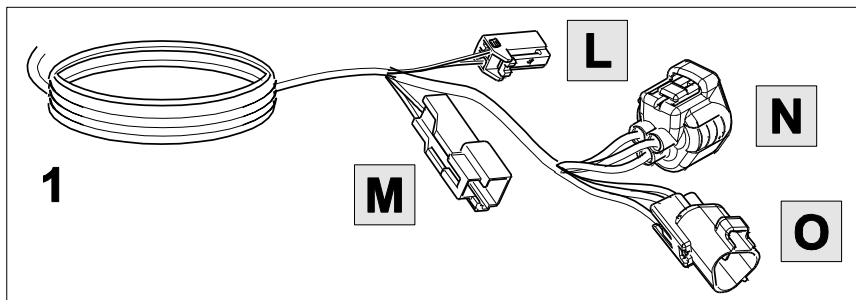

17

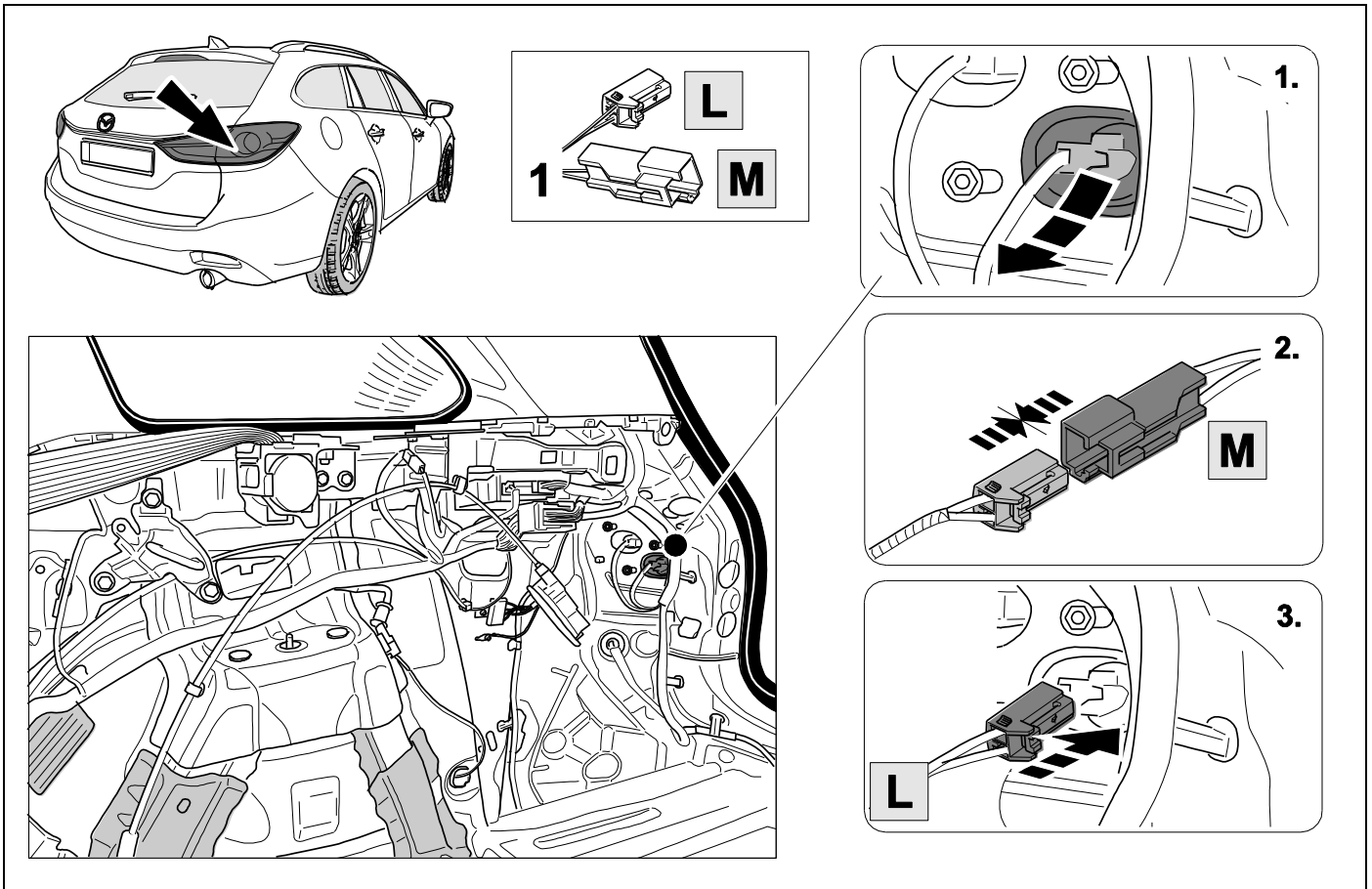

18

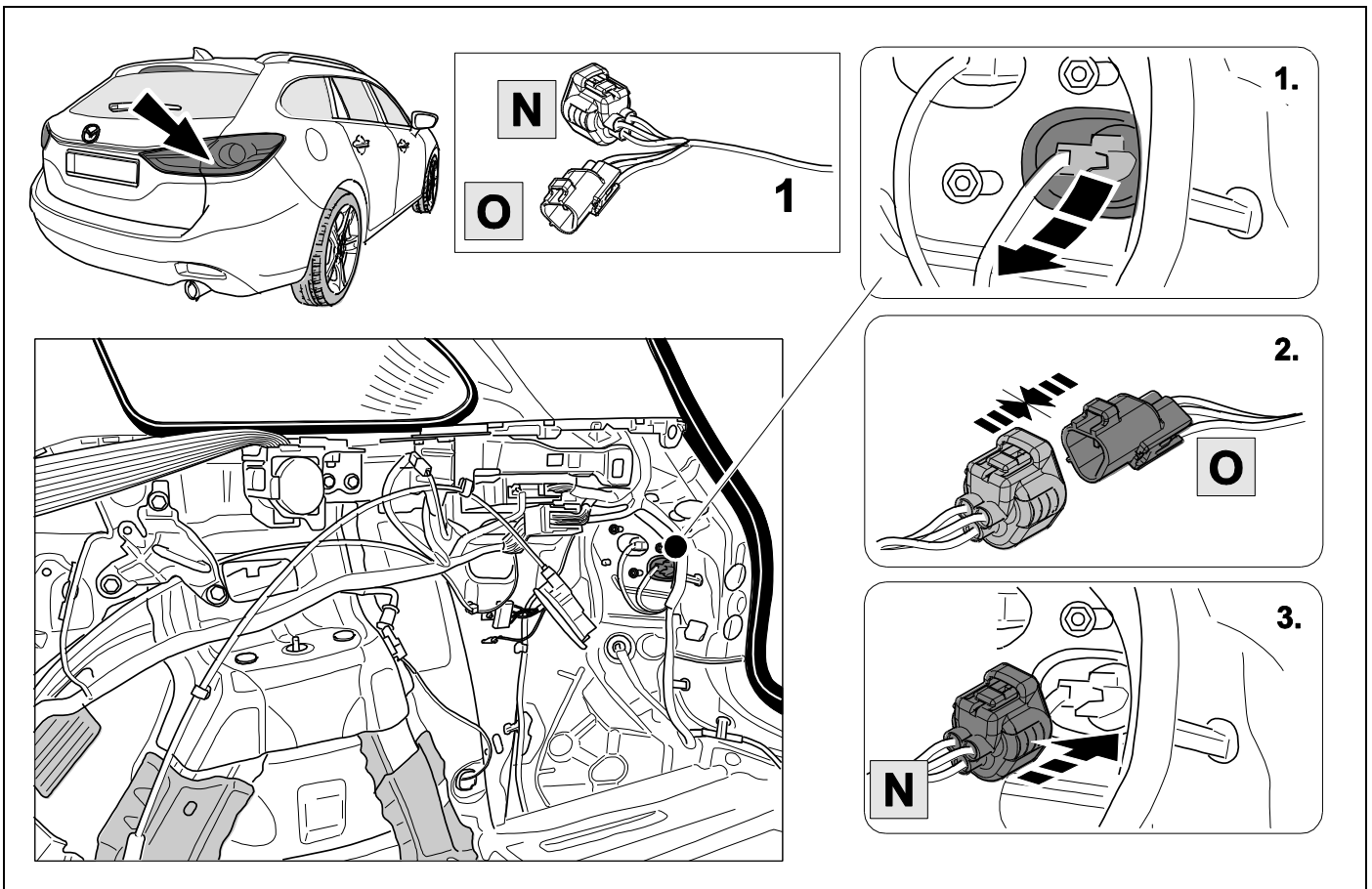

19

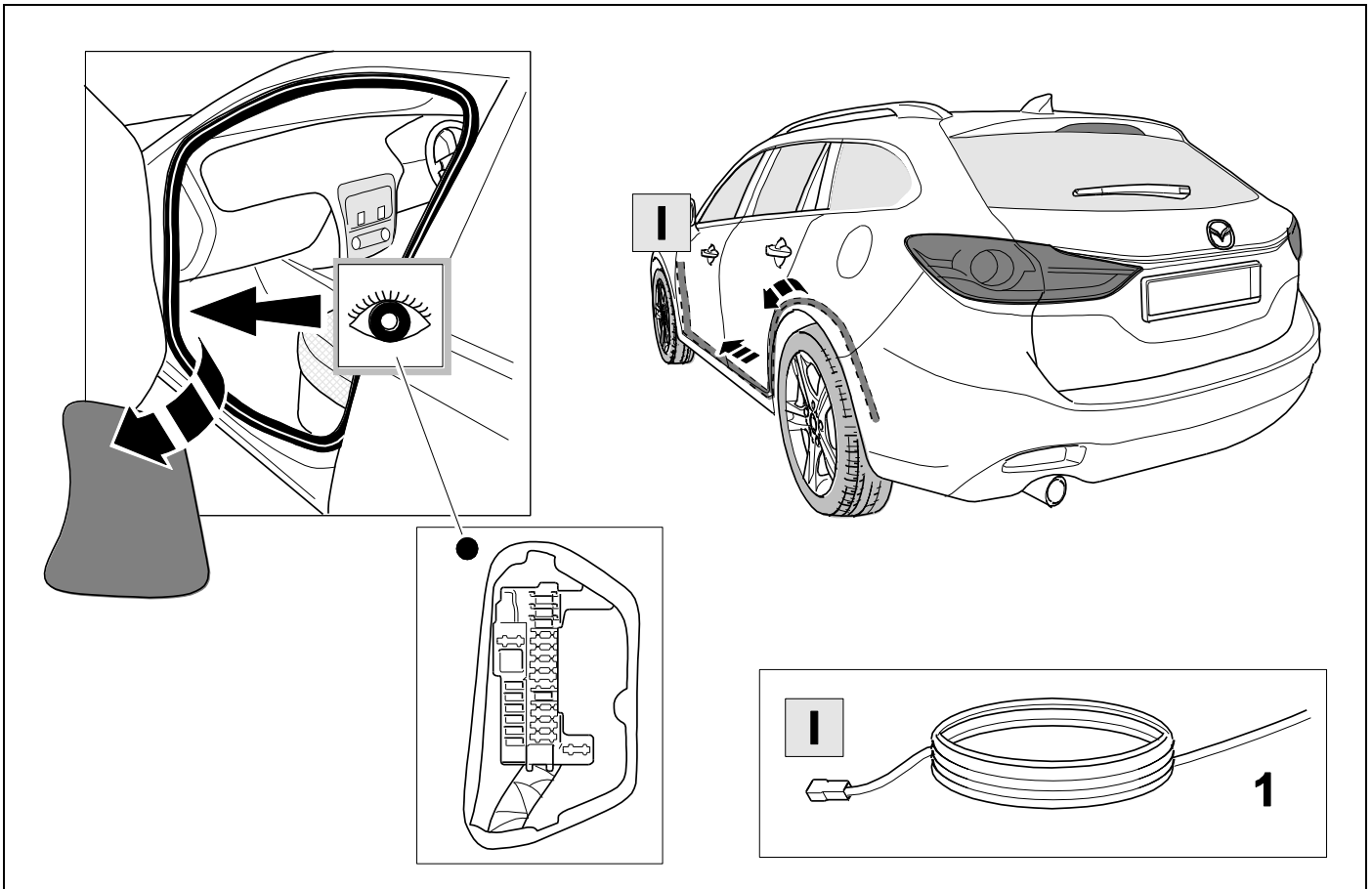

20

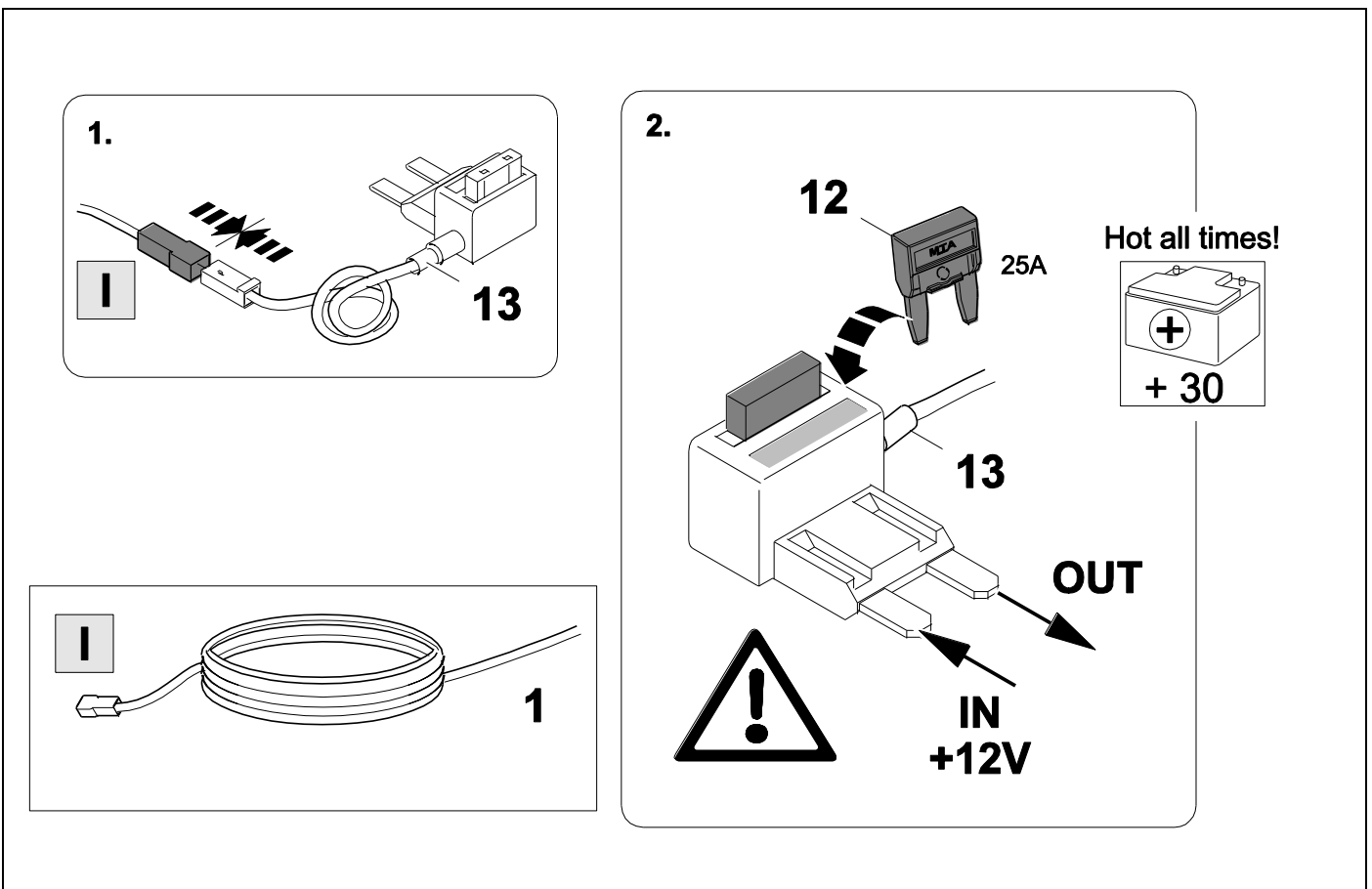

21

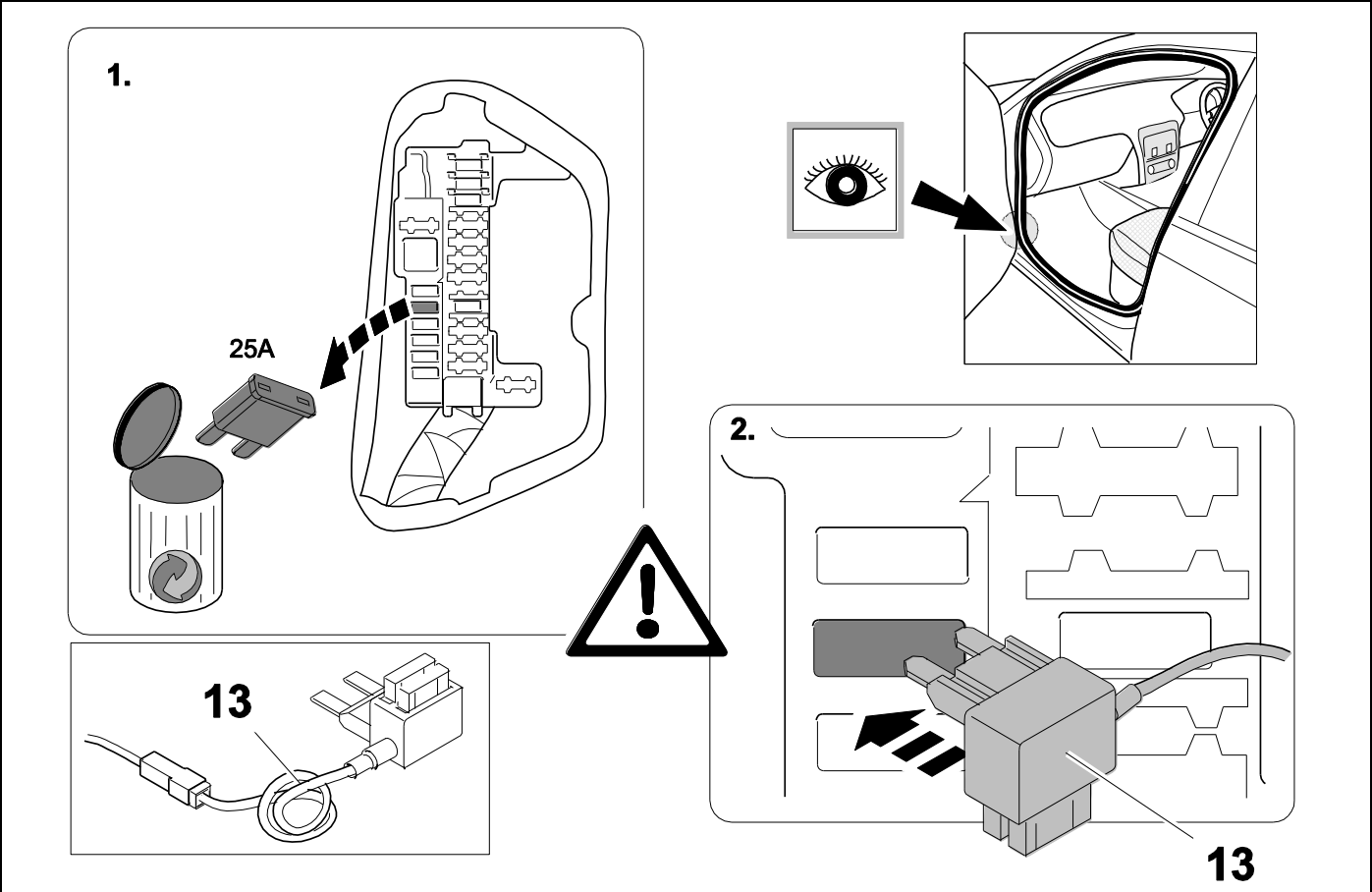

22

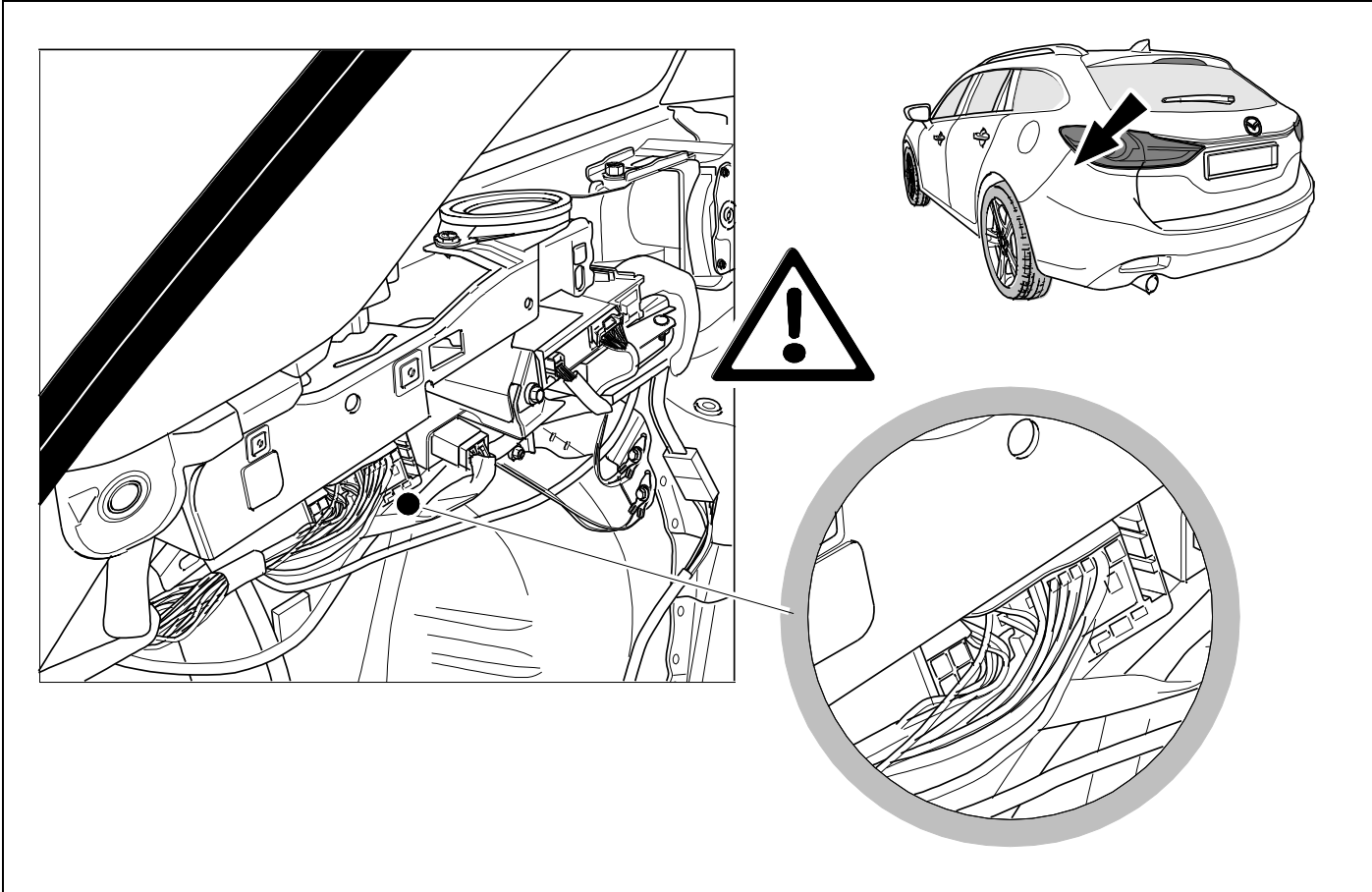

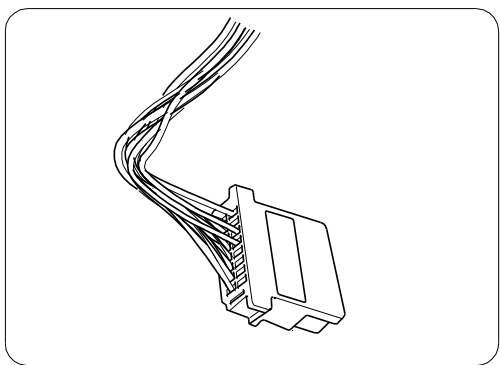
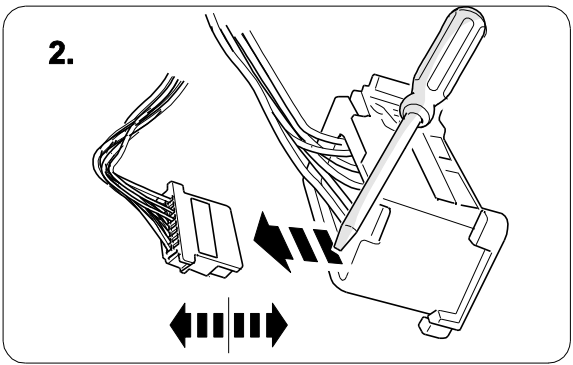
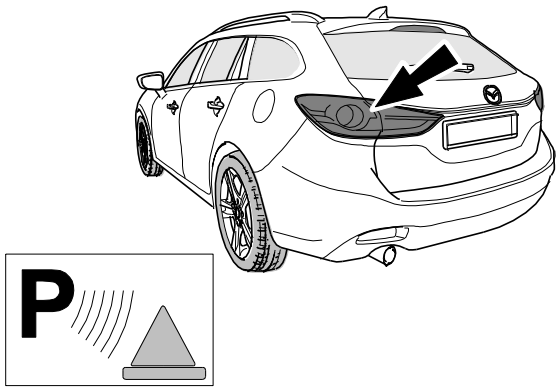
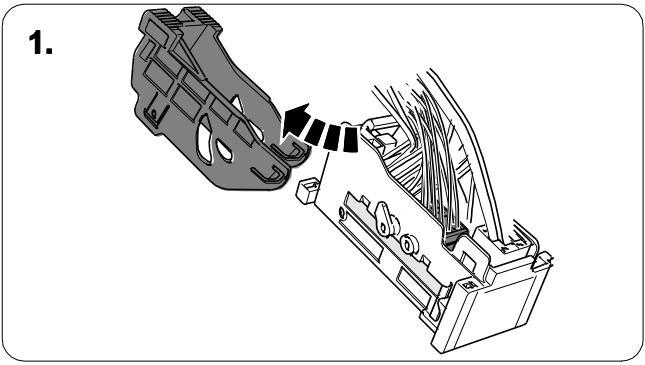

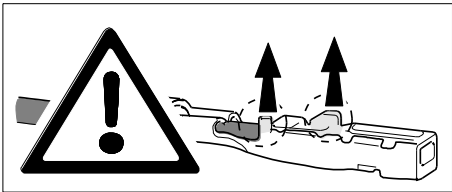
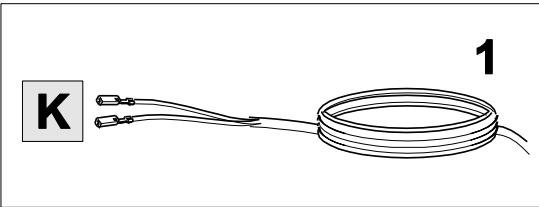
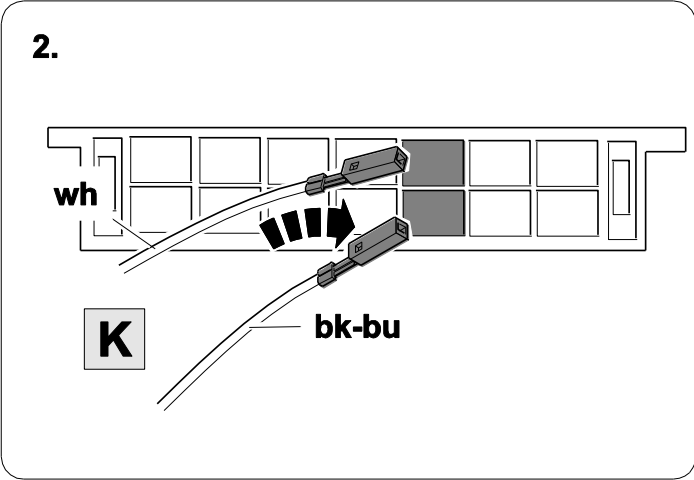
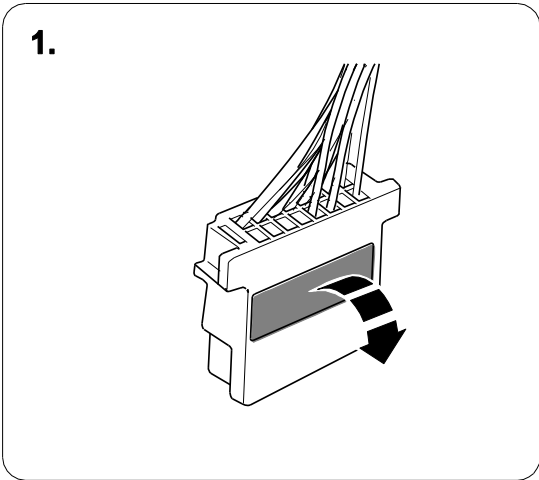
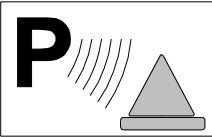
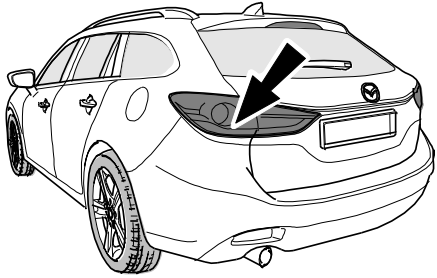
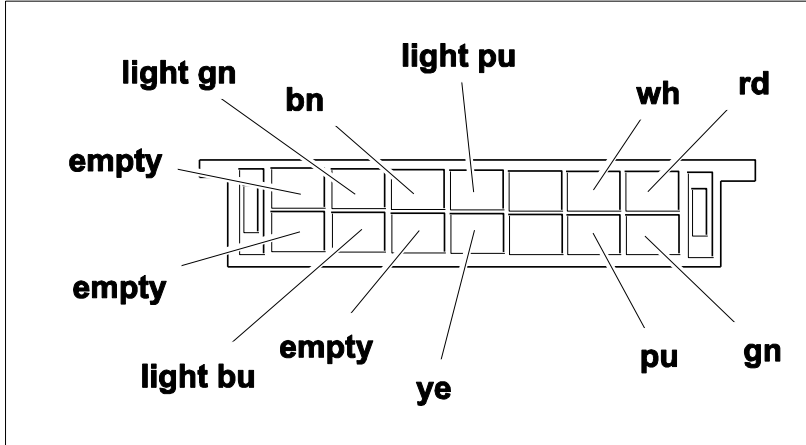

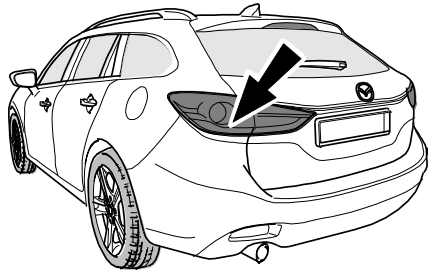
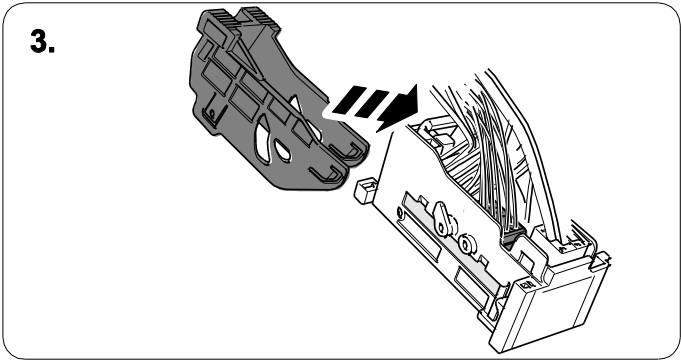
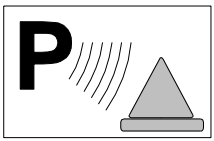
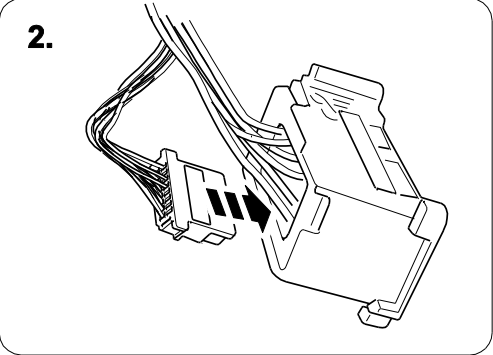
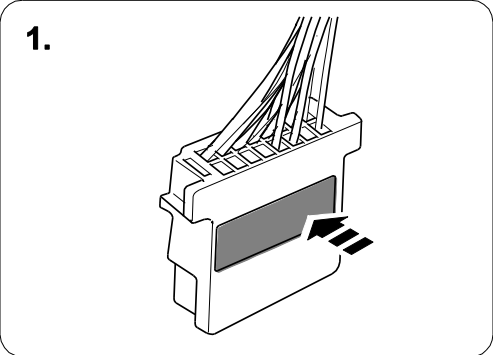

26 CHECK

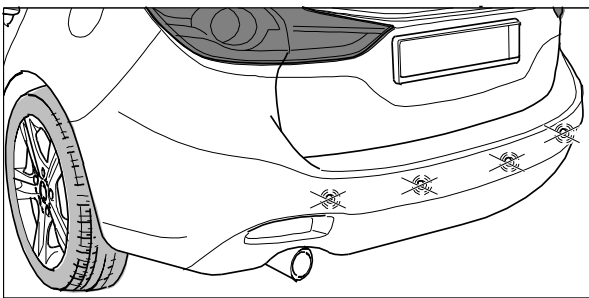
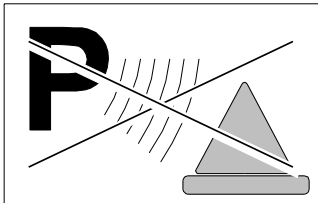
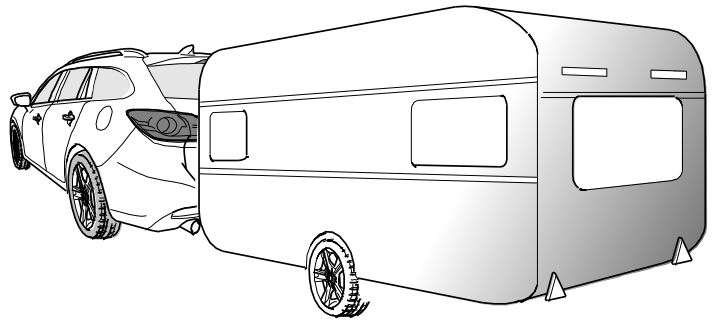
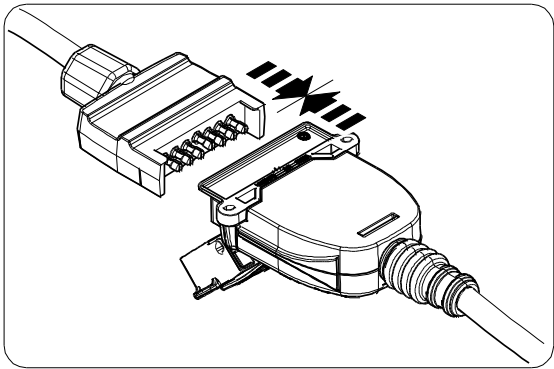

On the facelift GL models the PDC or SCBS-R system is not active while the parking brake is engaged.



In order to test automatic PDC and SCBS-R deactivation while stationary, plug in a trailer light tester or trailer and ensure the parking brake is disengaged. A deactivation message will be displayed as shown.

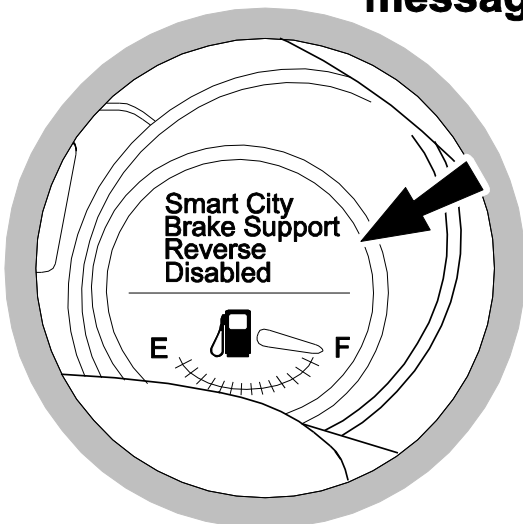



**BRAKE
CONTROLLER
PREPARED**

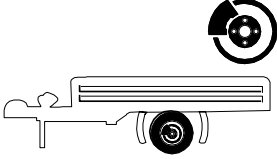

Trailer Brake Preparation

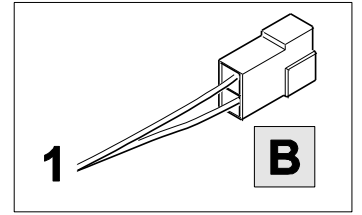

1.

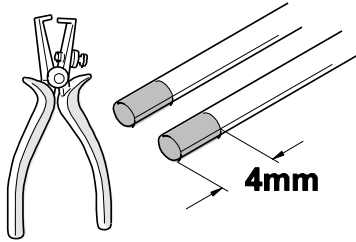

2.

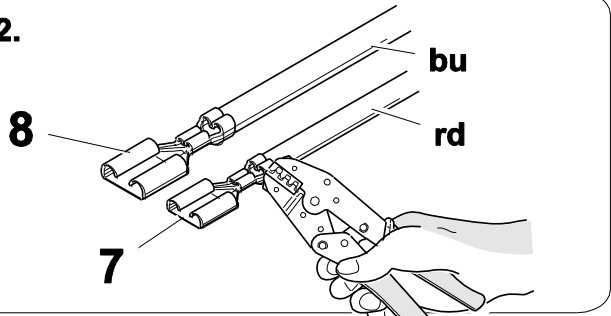

3.

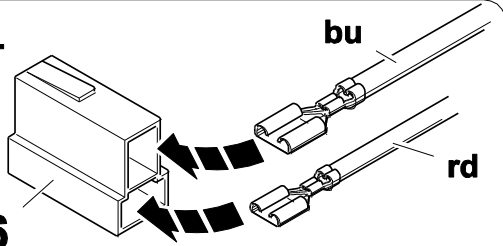

4.

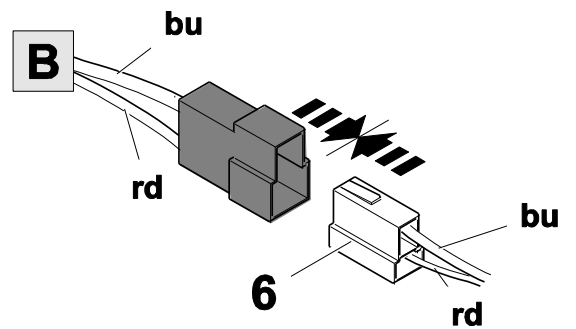

6

7

8

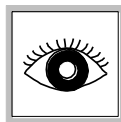
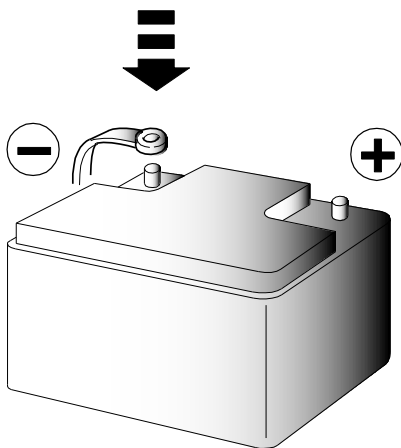
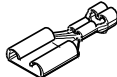
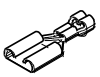
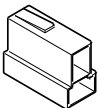

29

CHECK ALL LIGHTING FUNCTIONS

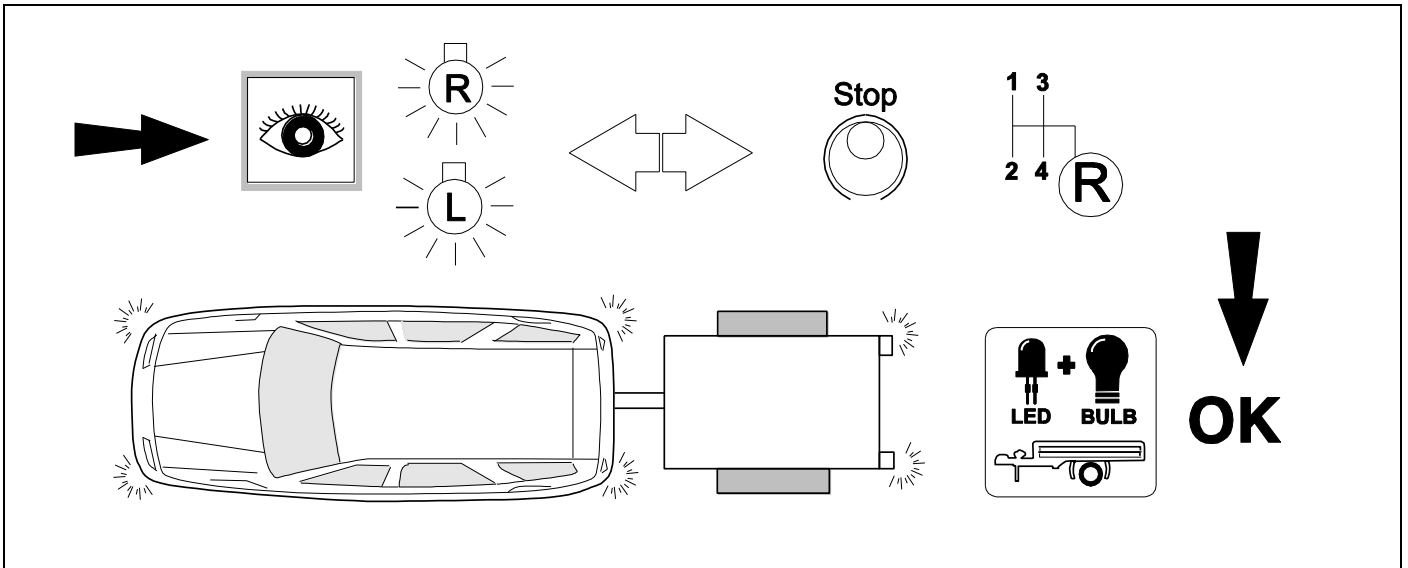

30

CHECK BULB OUT DETECTION

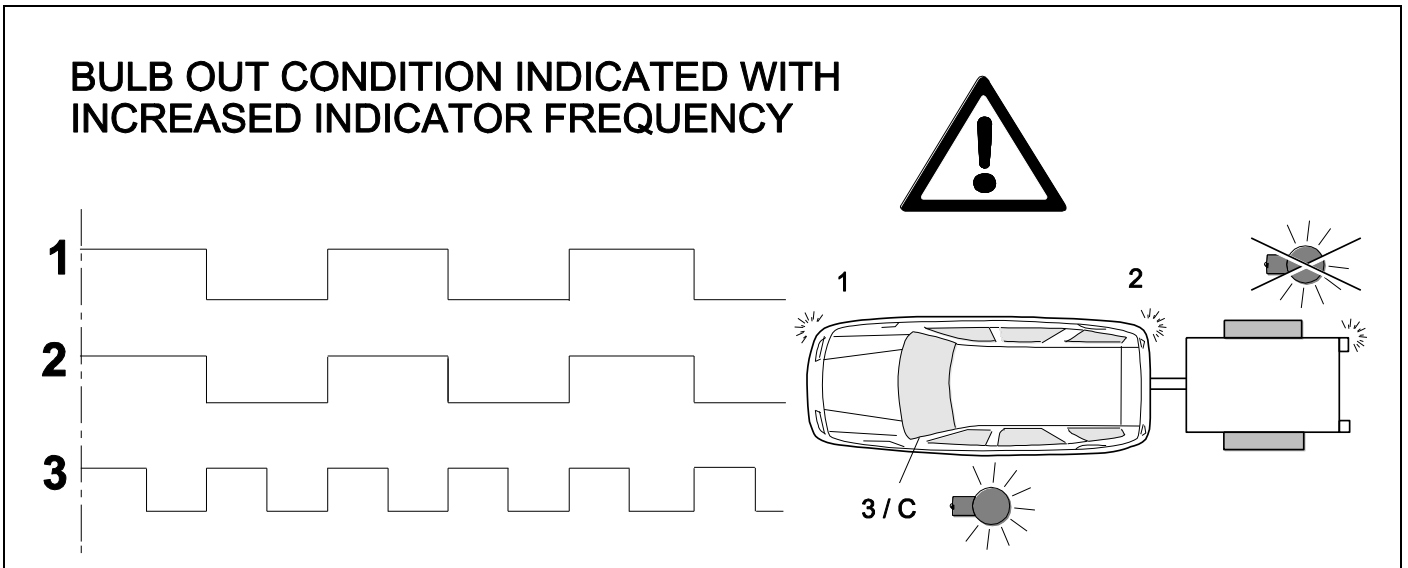

31

⇒ 20 + 21

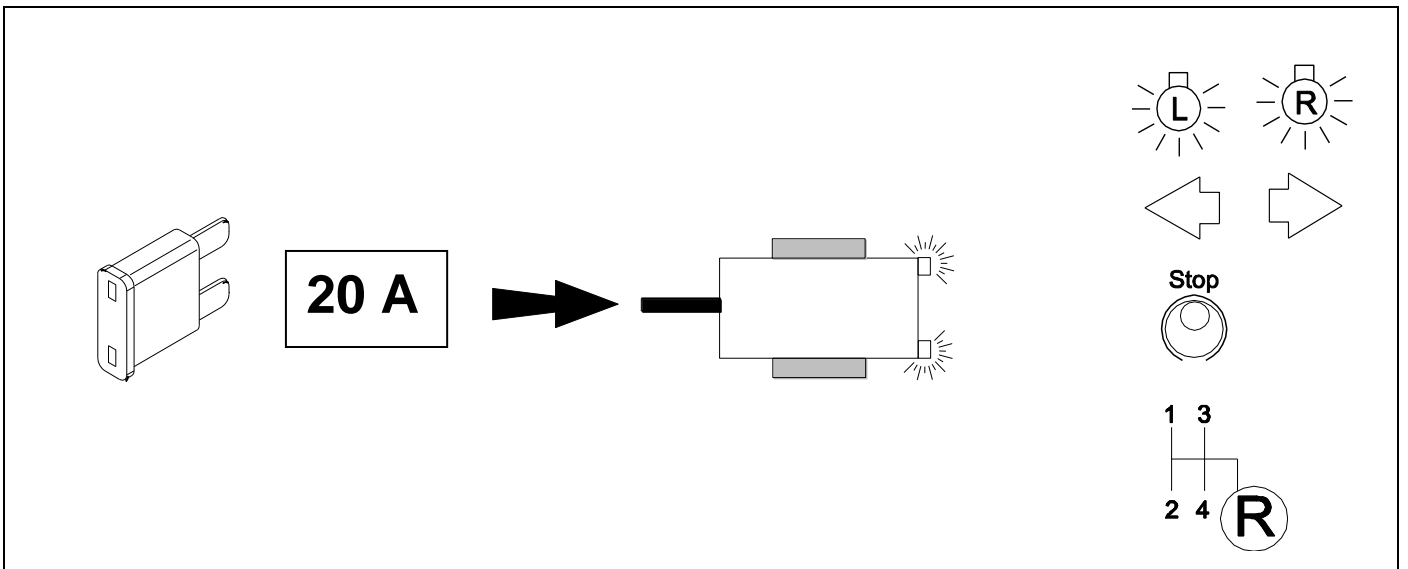

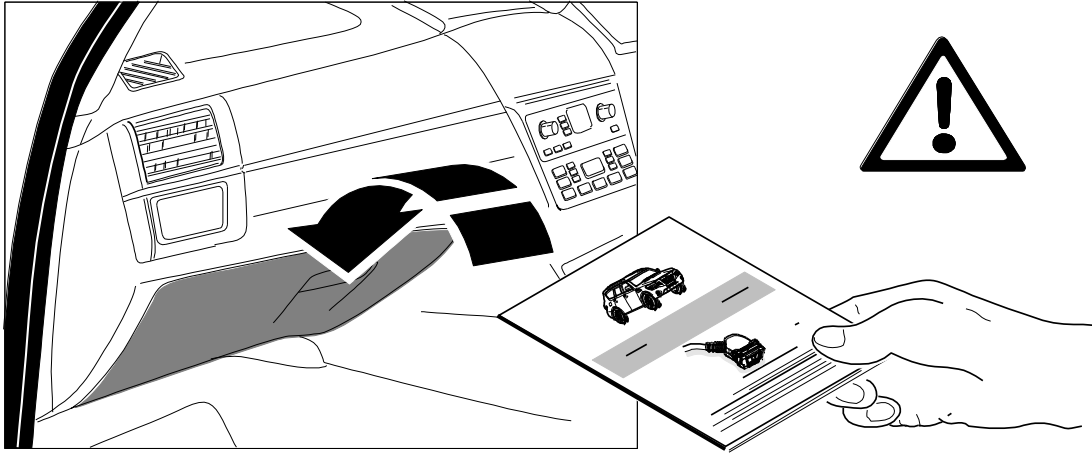

Subject to change in terms of construction, equipment and colour, and may contain errors.
The information and illustrations are non-binding.