

T2Z677



TOWBAR INFORMATION

Vehicle: Hyundai Kona

Towbar no: T2Z662

Lug no: L201C

Max weight: 1300

Max ball load: 300

FOR TRAILER TOWING ONLY

Recommended wiring harness part number:

Warning:

This product is for towing purposes only and must only be loaded as shown in you vehicle Owners Manual.

This towbar is NOT to be drilled, cut, welded or modified in any way.

Check behind chassis rail and body panels before drilling to ensure no hazards are present

General:

Before fitting this towbar read fitting instructions and check installation hardware is correct.

Check that the towbar is suitable for the vehicle and be wary of any changes to the vehicle design that may conflict with the fitting of this towbar.

After drilling, blow any filings clear, remove any swarf and treat exposed metal with a rust inhibitor.

If this vehicle requires a bumper cut out, please check to make sure that you measure twice and check twice before cutting any panels as some bumper profiles can change.

If you are not sure then please ask your towbar supplier



PROCESS FLOW

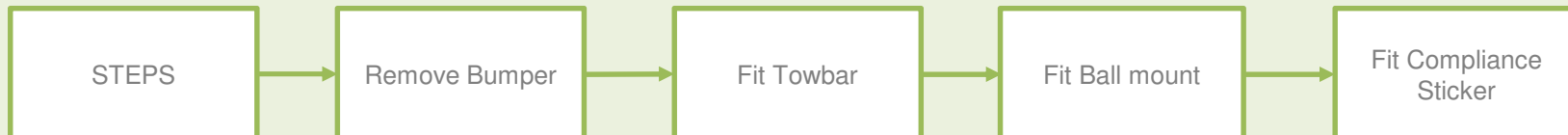

TORQUE TABLE

METRIC GARDE 8.8	UNC GRADE 8

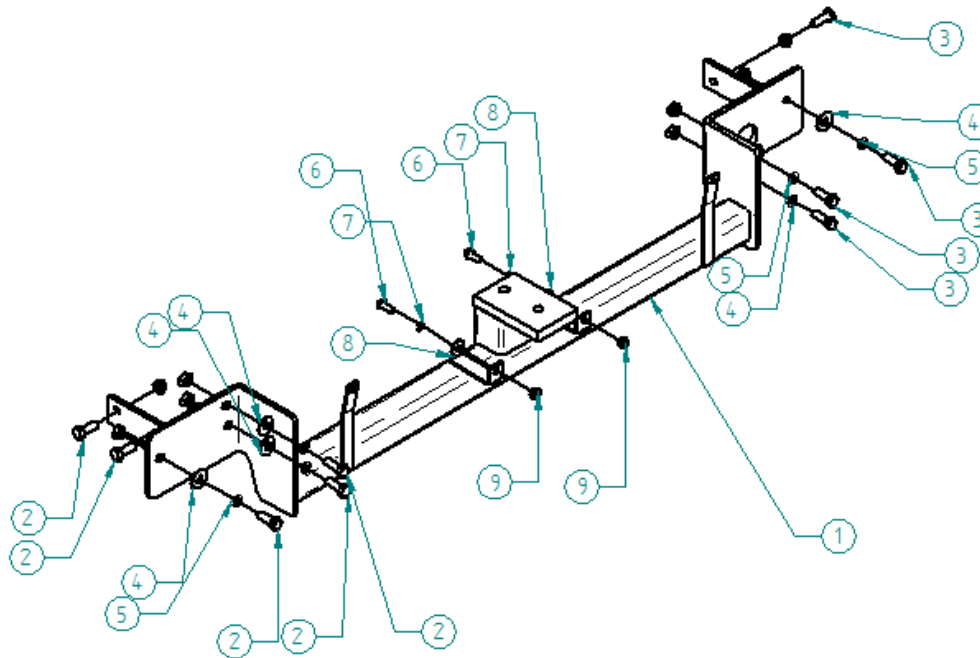

For safety reasons all fasteners should be tightened using a torque wrench - we recommend an adjustable torque wrench to reach the required bolt torque settings above.

EXPLODED DRAWING





HARDWARE KIT

NUM	ITEM	QTY
1	T2Z677	1
2	M10x30mmx1.25	6
3	M10 Flat Washer	6
4	M10 Shakeproof washer	6
5	M10x1.25 Nut	6
6	M8x20mmx1.25	2
7	M8 Flat Washer	2
8	M8 Shakeproof washer	2
9	M8x1.25 Nut	2

Step	What Important Step	Illustrations / Photo's	How / Why Explanations / Reasoning	Tools & Fasteners	
1	Remove rear bumper		<p>a) Remove 2 Philips head screws from the rear bar next to the tail lights.</p>		
2	Remove rear bumper		<p>a) Remove phillips head screws from inside the wheel arches.</p>		

Step	What Important Step	Illustrations / Photo's	How / Why Explanations / Reasoning	Tools & Fasteners	
3	Remove Rear Bumper		<p>a) Remove scrivets from the under the rear bumper from both sides.</p>		
4	Fit Tow Bar		<p>a) Remove the 3 scrivets from the underside of the rear bar.</p>		

Step	What Important Step	Illustrations / Photo's	How / Why Explanations / Reasoning	Tools & Fasteners	
5	Remove Rear Bumper		<ul style="list-style-type: none"> a) Unclip 2 wiring harness's from inside the rear bar. b) Once the rear crash bar is removed, Remove the sensor shown in the top image on the bottom left as it will need to be re-attached to the tow bar. 		
6	Remove rear bumper		<ul style="list-style-type: none"> a) Unbolt the two M10 bolts on either side of the chassis rails. b) Once unbolted pull the rear bar off starting from the wheel arches and continue carefully. 		

Step	What Important Step	Illustrations / Photo's	How / Why Explanations / Reasoning	Tools & Fasteners	
7	Fit Towbar		<ul style="list-style-type: none"> a) Fit tow bar with supplied hardware. b) Two m12x1.25 bolts into the chassis rail and three on the face of the bar. 		
8	Fit Towbar		<ul style="list-style-type: none"> a) Fit 3 M12 bolts to the front mounting plate. On both sides. 		

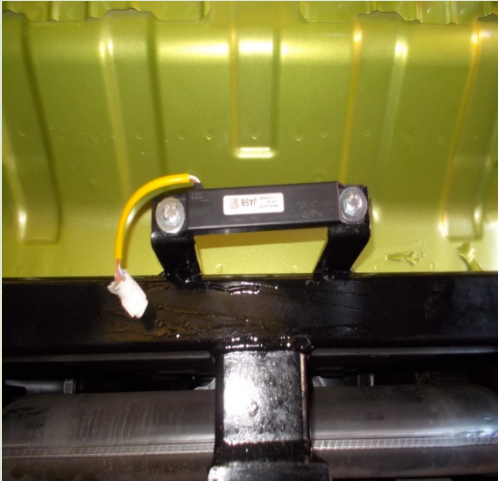
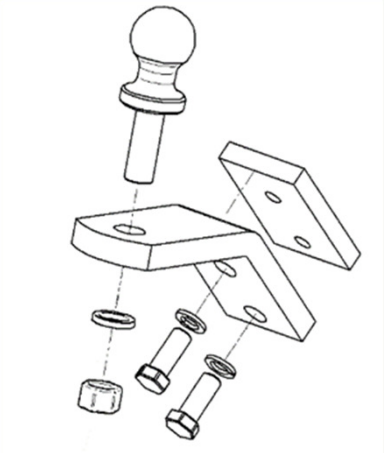
Step	What Important Step	Illustrations / Photo's	How / Why Explanations / Reasoning	Tools & Fasteners	
8	Fit Tow bar		<ul style="list-style-type: none"> a) Re attach Crash bar sensor to tow bar. b) Refit the rear bar 		
	FIT BALL MOUNT		<ul style="list-style-type: none"> a) FIT SUPPLIED LUG TO THE TOWBAR 		

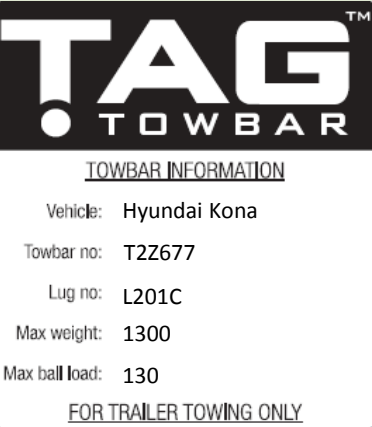
Step	What Important Step	Illustrations / Photo's	How / Why Explanations / Reasoning	Tools and Fasteners
	FIT COMPLIANCE STICKER	 <p>TAGTM TOWBAR</p> <p><u>TOWBAR INFORMATION</u></p> <p>Vehicle: Hyundai Kona Towbar no: T2Z677 Lug no: L201C Max weight: 1300 Max ball load: 130</p> <p><u>FOR TRAILER TOWING ONLY</u></p>	<p>a) ATTACH TO B PILLAR b) This sticker must be attached at the time of fitting otherwise warranty could be affected</p>	

TAG TOWBAR WARRANTY STATEMENT

The manufacturer of TAG branded products, warrants your TAG Towbar for its full product life under the following conditions:

- You can show proof of purchase.
- The towbar has been correctly installed by a suitably qualified installer.
- The towbar has not been modified or abused in any way and has only been used for the purpose intended.
- The towbar was not fitted second hand to your vehicle.

The extent of this warranty includes materials and workmanship used in the manufacture of the towbar and is to the equivalent value of current, full replacement cost.

Nothing stated or implied in this warranty limits in any way, the statutory rights that you may have.

To make a claim visit the original installer in the first instance or, if you are unable to or are not satisfied with their help, then contact us direct by phone on 07 3208 3022 or via email qldsales@arandatowbars.com.au