

Fitting Instructions



SKU

PRODUCT

T4S516

**TAG Heavy Duty Towbar to
suit Subaru Forester
(03/2008 - 01/2013)**



Scan for latest
version of these
instructions

SPECIFICATIONS

- Towbar Class: Heavy Duty
- Towing Capacity: 1200kg / 1400kg

IN THIS GUIDE

- Fitment Instructions
- Torque Settings
- Warranty Info

Towbar Fitting Instructions

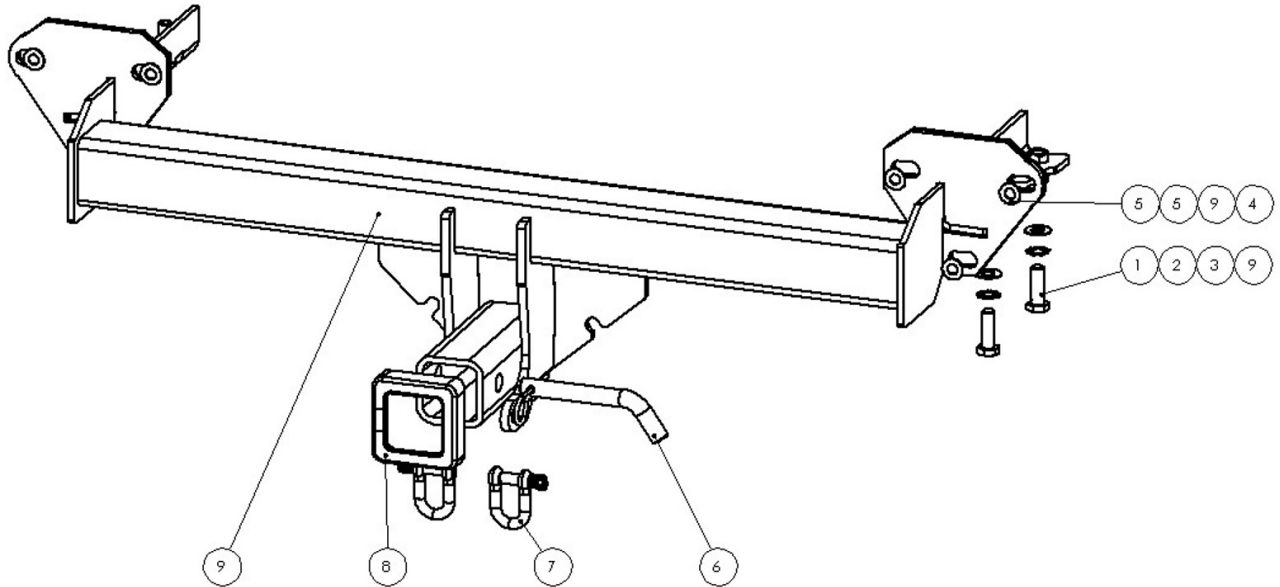

Tools Required: Spanners, Screwdriver, Sockets, Torque wrench

ITEM NO.	DESCRIPTION	QTY.	ITEM NO.	DESCRIPTION	QTY.
1	M12x1.5x35 Bolt	4	6	Class 4 Pin & Clip	1
2	M12 Shakeproof Washer	4	7	TAG D-Shackle - 10mm 1000kg Galvanised	2
3	M12 Flat Washer	4	8	TAG Hitch Receiver Cover	1
4	Spacer Plate	2	9	Towbar Assembly	1
5	M10 Flat Washer	6	10	L4120 Ball Mount (Not Shown)	1

Step-By-Step Instructions

Warning:

- This product is for towing purposes only and must only be loaded as shown in your vehicle Owner's Manual.
- This towbar is NOT to be drilled, cut, welded, or modified in any way.
- Check behind chassis rail and body panels before drilling to ensure no hazards are present
- All load ratings shown are under the assumption your trailer has a functional braking system installed
- When installed in positions other than the one depicted in these instructions the Tow Ball Mount may interfere or obstruct certain features of your vehicle (tailgate opening, Chassis clearance, etc.)

General:

- Before fitting this towbar read fitting instructions and check installation hardware is correct.
- Check that the towbar is suitable for the vehicle and be wary of any changes to the vehicle design that may conflict with the fitting of this towbar. (Tray, Canopy, Suspension etc.)
- After drilling, blow any filings clear, remove any swarf and treat exposed metal with a rust inhibitor.
- The high tensile fasteners supplied with this product are an integral feature to achieving the specified rating, if replacement is required ensure that fasteners of the same grade (8.8) & quality are used. Contact an authorised TAG distributor or the TAG fitment centre - (07) 3208 3022 - if further information is required.

Towbar Maintenance and Care:

It is recommended, when not in use, the Tow Ball Mount assembly and class 4 Pin and Clip is stored inside the car away from moisture to prevent standing water from forming rust. Inspect to ensure, on regular basis, fasteners are torqued to the specifications below and in good condition.

**Ensure that the fitting instructions are read and understood prior to fitment
Place these instructions in the vehicle's glovebox after installation is completed**

Towbar Fitting Instructions



Step 1. Remove Bumper

- a. Remove screws and scrivenets from wheel arches and underside of bumper.
- b. Beginning at each wheel arch, carefully pull bumper out at sides. Remove bumper rearwards from the middle.
- c. Remove and discard impact beam and top aluminium bumper locator
- d. Remove exhaust from rubber hangers
- e. Remove heat shield for access to underside of subframe.
- f. Drill 2x existing holes in underside of **each** subframe to M12.
- g. Deburr all raw edges and apply rust inhibitor.

Step 2. Fit Towbar

- a. Install tow bar into sub frame and onto existing factory studs on rear panel.
- b. Insert spacer plate between tow bar and back of vehicle
- c. Aluminium bumper locator needs to be fitted onto top stud.
- d. Insert 4x M12 bolts with square plates and washers provided through bottom of sub frame. Secure loosely.
- e. Tighten all bolts to torque specification on page 2.
- f. Re-install heat shields and exhaust.

Step 3. Apply Compliance Label

- a. Apply one of the compliance labels to the pillar of the driver's door. Leave the remaining label and the fitting instructions in the vehicle handbook



Torque table for bolt tightening

Diameter	Pitch	Grade	Torque	Unit
M8	1.25	8.8	29	Nm
M10	1.25	8.8	57	Nm
M10	1.50	8.8	44	Nm
M12	1.25	8.8	101	Nm
M12	1.50	8.8	97	Nm
M12	1.75	8.8	77	Nm
M14	2.00	8.8	122	Nm
M16	2.00	8.8	190	Nm
Imperial Bolt Torque Settings				
3/8"	UNC	8	44.75	Nm
1/2"	UNC	8	108.5	Nm

TAG Warranty Statement

SWD warrants your TAG Towbar for its full product life under the following conditions:

- You can show proof of purchase.
- The towbar has been correctly installed by a suitably qualified installer.
- The towbar has not been modified or abused in any way and has only been used for the purpose intended.
- The towbar was not fitted second hand to your vehicle.

The extent of this warranty includes materials and workmanship used in the manufacture of the towbar and is to the equivalent value of current, full replacement cost.

Nothing stated or implied in this warranty limits in any way, the statutory rights that you may have.

To make a claim visit the original installer in the first instance or, if you are unable to or are not satisfied with their help, then contact us direct by phone on 1300 669122 or visit www.swd.com.au