

Fitting Instructions



SKU

PRODUCT

T4H611

TAG Heavy Duty Towbar to suit Holden Colorado 7 (11/2012 - 06/2021), Trailblazer (01/2016 - 06/2021), Isuzu MU-X (11/2013 - 06/2021)



Scan for latest version of these instructions

SPECIFICATIONS

- Towbar Class: Heavy Duty
- Towing Capacity: 3000kg

IN THIS GUIDE

- Fitment Instructions
- Torque Settings
- Warranty Info

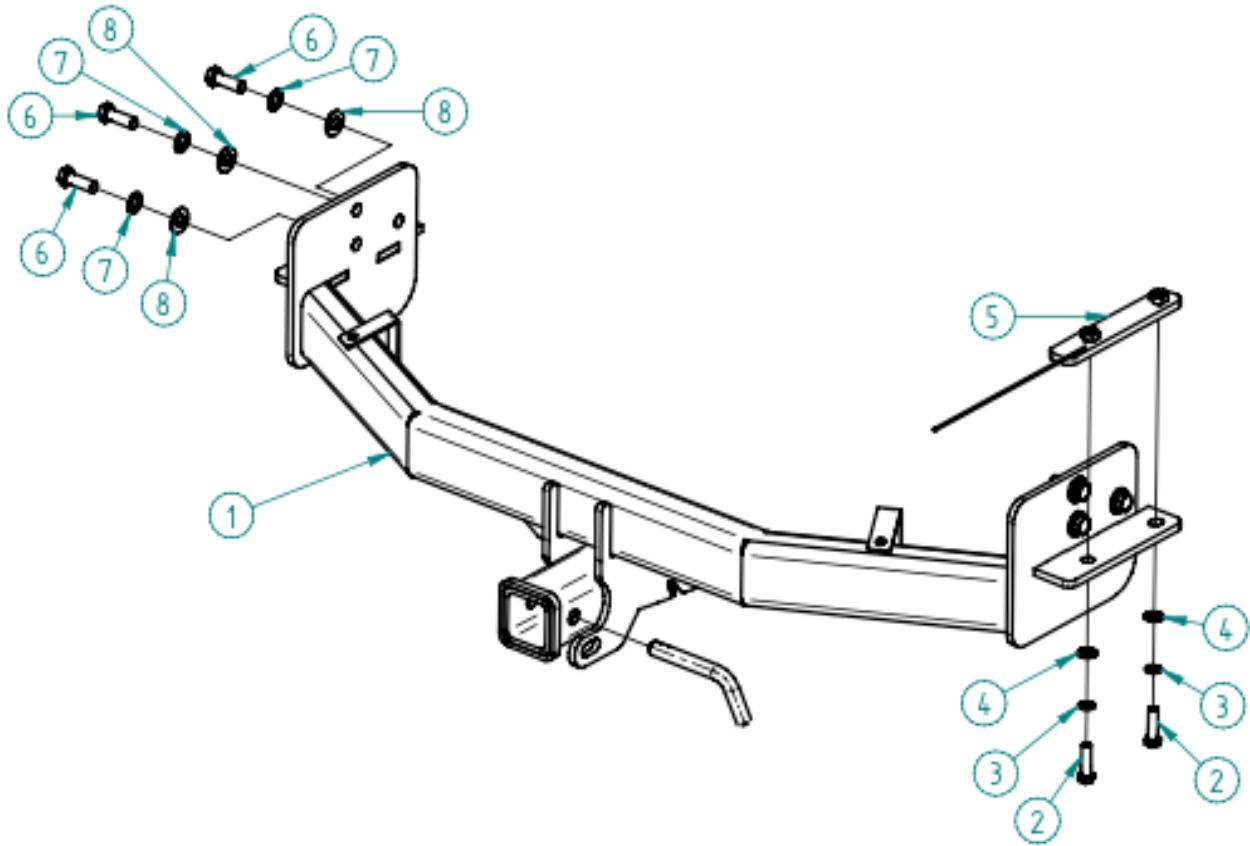

Tools Required: Spanners, Sockets, Torque Wrench

No.	Description	Qty
1.	Towbar	1
2.	M10 x 35 x 1.25 Pitch bolt	4
3.	M10 Star Washer	4
4.	M10 Flat Washer	4
5.	Nut Plate	1
6.	M12 x 35 x 1.25 Pitch bolt	6
7.	M12 Star Washer	6
8.	M12 Flat washer	6
9.	Class 4 Pin and Clip	1
10.	L4045 ballmount	1
11.	Compliance Plate	1
12.	Door Sticker	1

Towbar Fitting Instructions



Step-By-Step Instructions

Warning:

Safety First: Always use correct safety equipment.

This towbar is NOT to be drilled, cut, welded or modified in any way.

Check the surrounding area before drilling into chassis or body panels for fuel lines, wiring harnesses and other components that may be a hazard.

General:

Before fitting this towbar read fitting instructions and check installation hardware is correct.

Check that the towbar is suitable for the vehicle and be wary of any changes to the vehicle design that may conflict with the fitting of this towbar.

After drilling, blow any filings clear, remove any swarf and treat exposed metal with a rust inhibitor.

If this vehicle requires a bumper cut out, please check to make sure that you measure twice and check twice before cutting any panels as some bumper profiles can change.

If you are not sure then ask your towbar supplier.

Tighten all bolts as specified on the last page.

1. Remove Spare Tyre and Towing hook

- a. Undo Spare tyre
- b. Remove and discard towing hook as shown in the image



Towbar Fitting Instructions



2. Remove bumper brackets

- a. Remove and discard bumper brackets as shown on the image

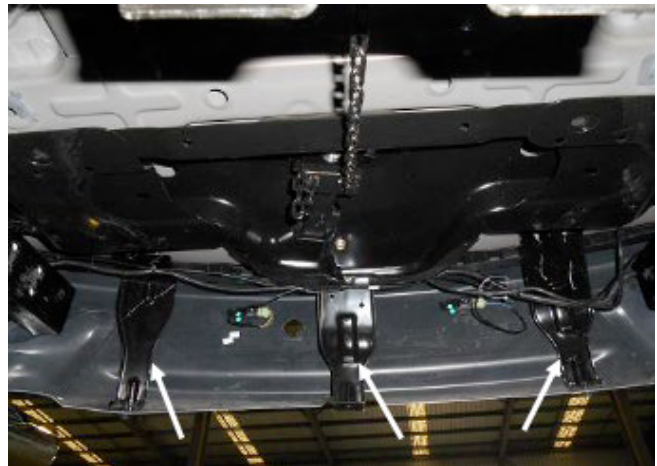

3. Bumper Cut

- a. Find centre of the bumper bar
- b. Make the bumper cut with given measurements (Note: Bumper removal not required) as shown

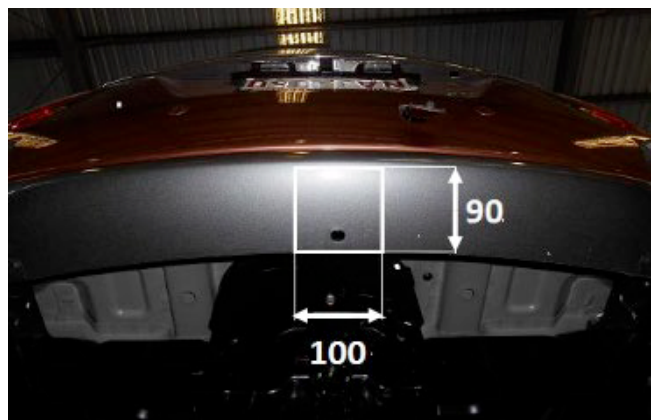

4. Remove Exhaust

- a. Remove exhaust from rubber hanger



5. Fitting Nut and Compliance Plates

- a. Slide nut plate (Item 5 in Hardware Kit list) into driver's side chassis rail
- b. Fit supported compliance plate to the towbar



Towbar Fitting Instructions



6. Towbar Fitment

- a. Slide the towbar between the chassis rails as shown above
- b. Insert and tighten all bolts loosely and evenly
- c. Torque all bolts accordingly to torque spec

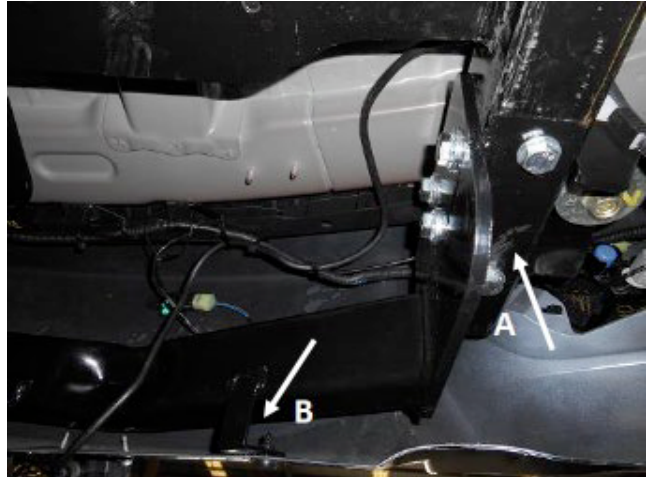

7. Finishing Up

- a. Fit door sticker inside of the driver's door pillar.
- b. Refit exhaust and spare tyre.
- c. Fit the ball mount to the towbar.

Towbar Fitting Instructions



Torque table for bolt tightening

Diameter	Pitch	Grade	Torque	Unit
M8	1.25	8.8	29	Nm
M10	1.25	8.8	57	Nm
M10	1.50	8.8	44	Nm
M12	1.25	8.8	101	Nm
M12	1.50	8.8	97	Nm
M12	1.75	8.8	77	Nm
M14	2.00	8.8	122	Nm
M16	2.00	8.8	190	Nm
Imperial Bolt Torque Settings				
3/8"	UNC	8	44.75	Nm
1/2"	UNC	8	108.5	Nm

TAG Warranty Statement

SWD warrants your TAG Towbar for its full product life under the following conditions:

- You can show proof of purchase.
- The towbar has been correctly installed by a suitably qualified installer.
- The towbar has not been modified or abused in any way and has only been used for the purpose intended.
- The towbar was not fitted second hand to your vehicle.

The extent of this warranty includes materials and workmanship used in the manufacture of the towbar and is to the equivalent value of current, full replacement cost.

Nothing stated or implied in this warranty limits in any way, the statutory rights that you may have.

To make a claim visit the original installer in the first instance or, if you are unable to or are not satisfied with their help, then contact us direct by phone on 1300 669122 or visit www.swd.com.au